

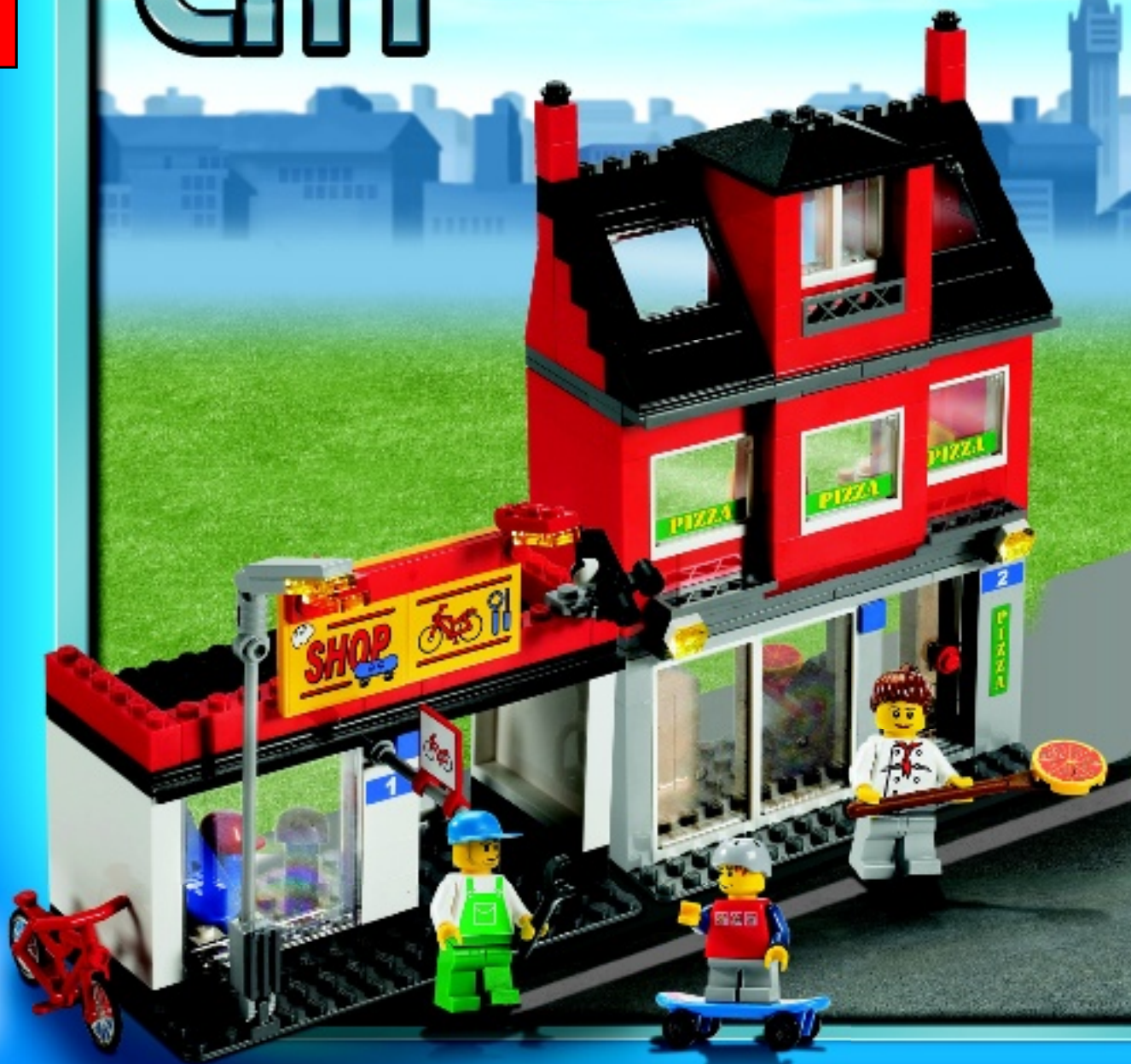

CITY

60031

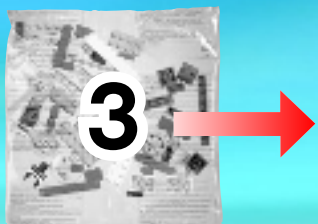





+

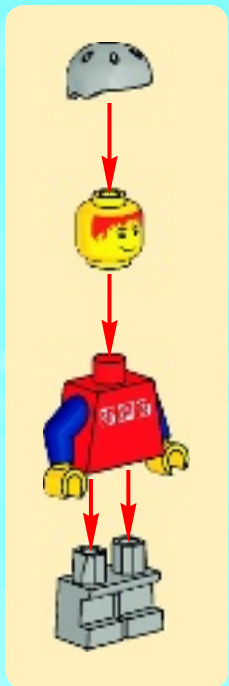

1

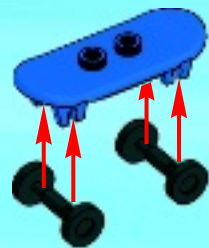

2



1

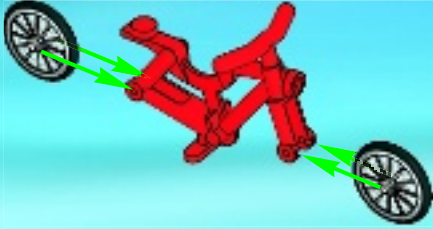

2



1

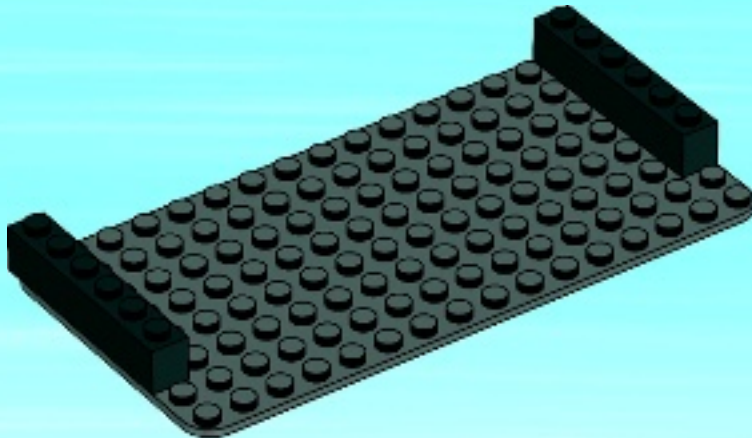

2

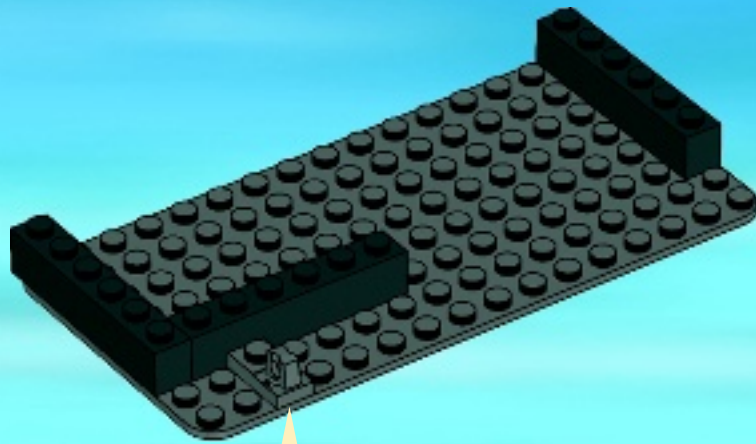

3

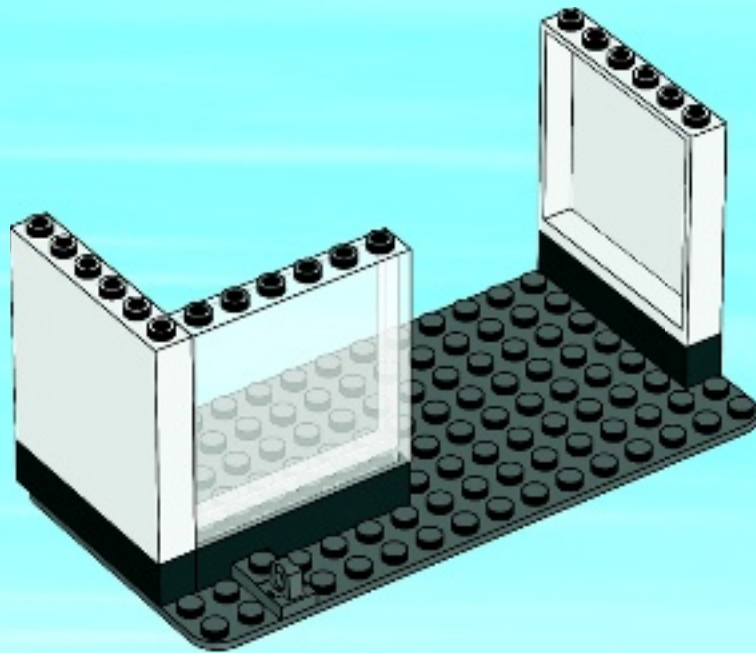

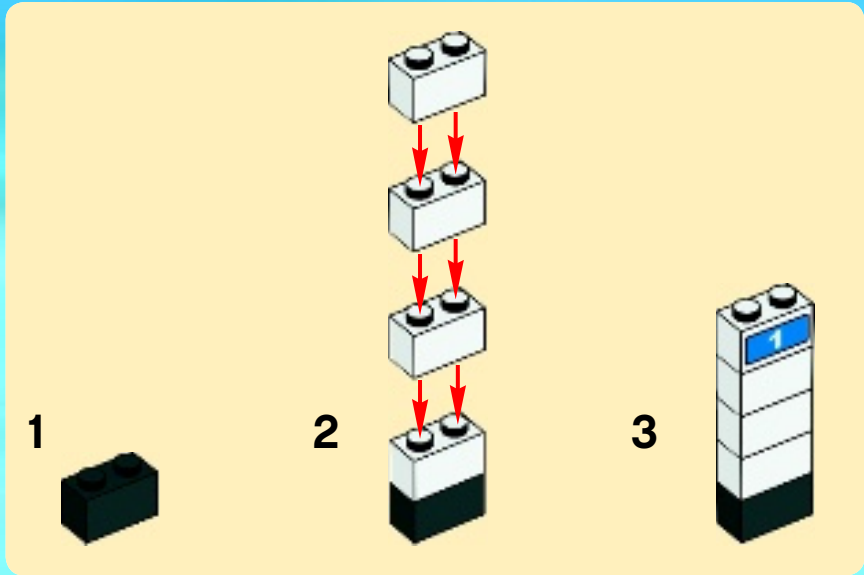

4

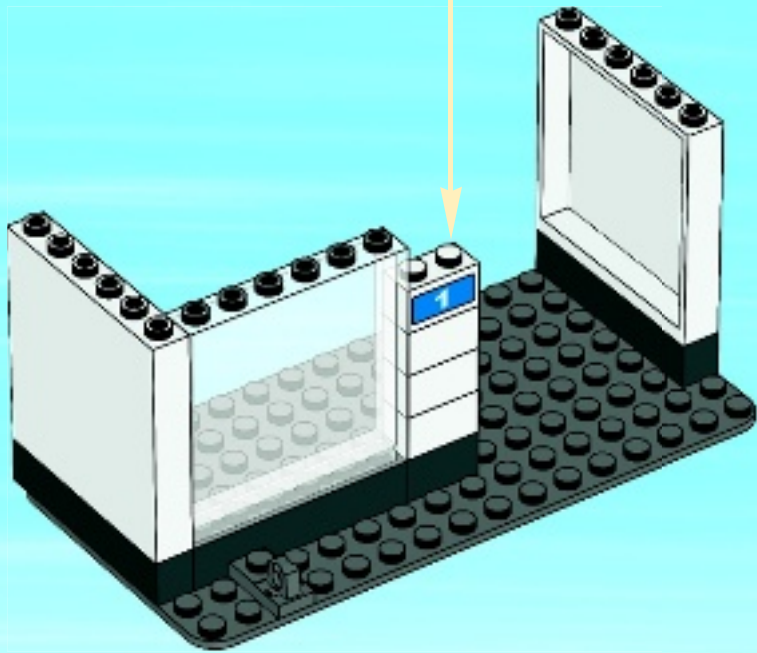

5

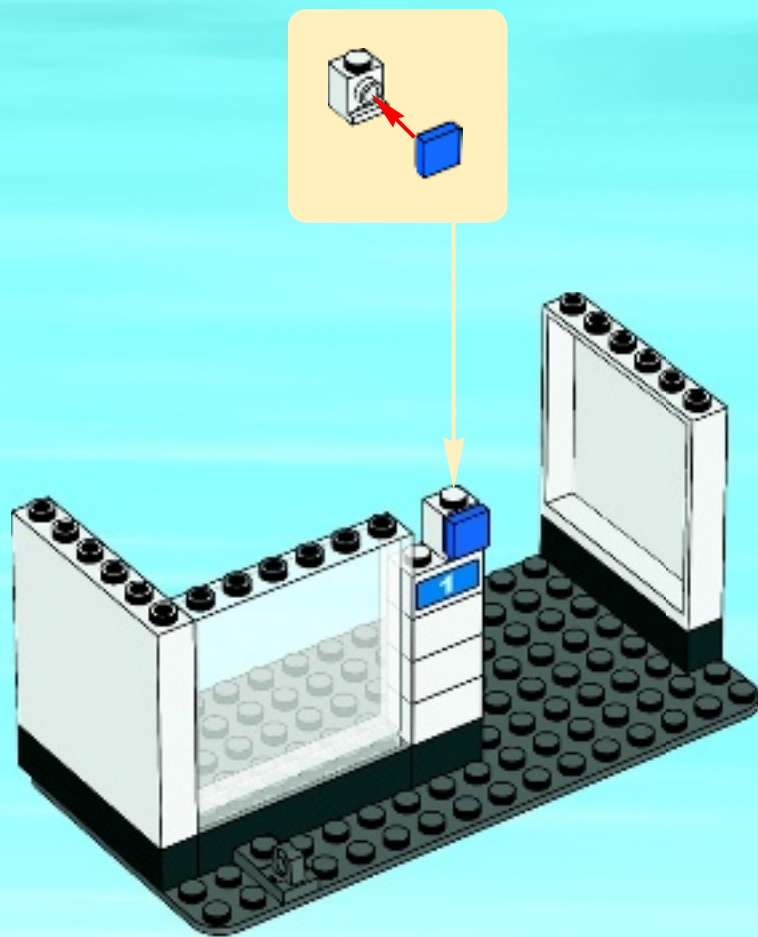

1

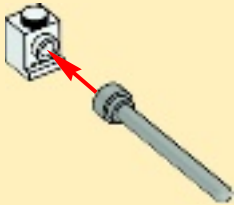

2

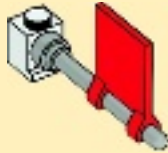

3

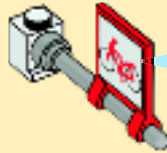

6

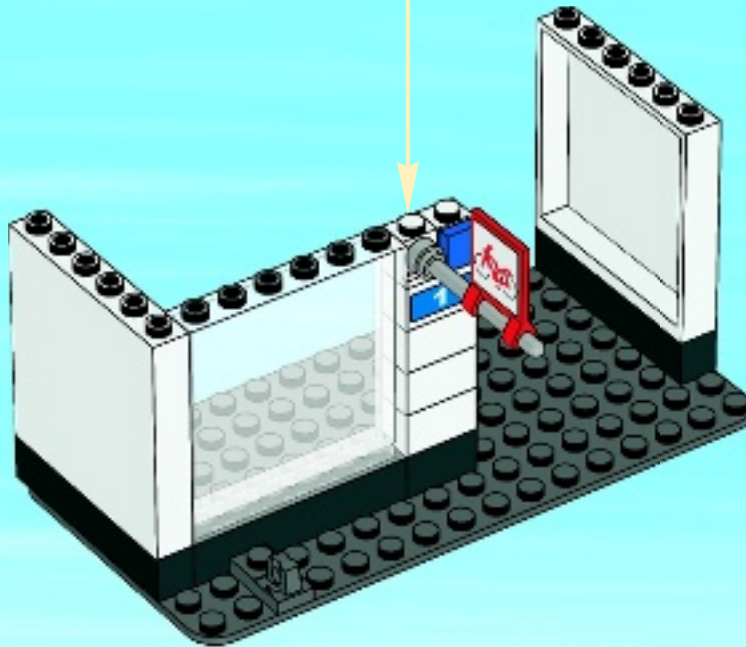

7

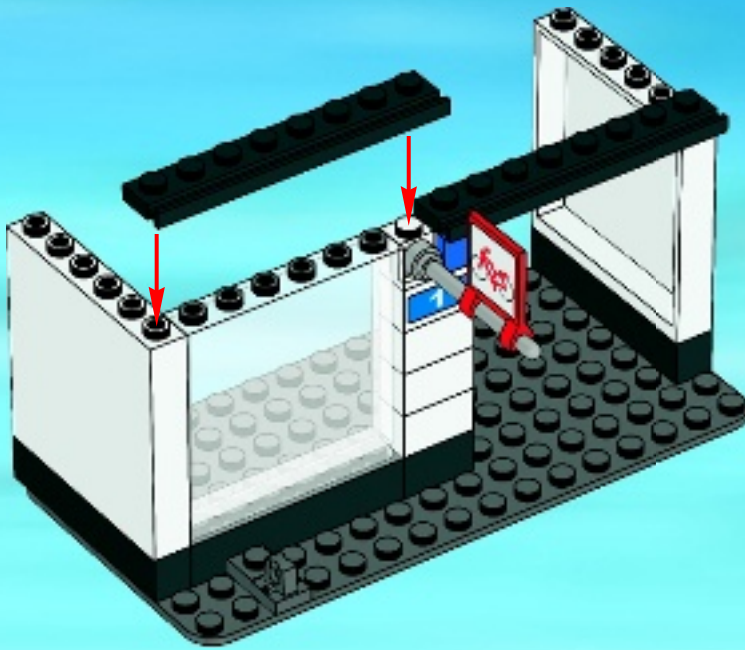

8

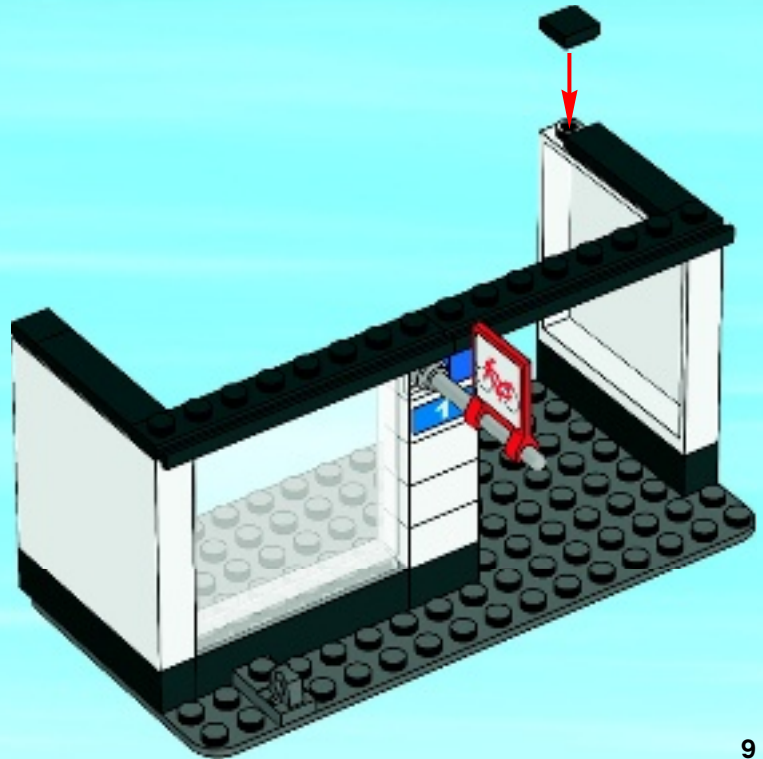

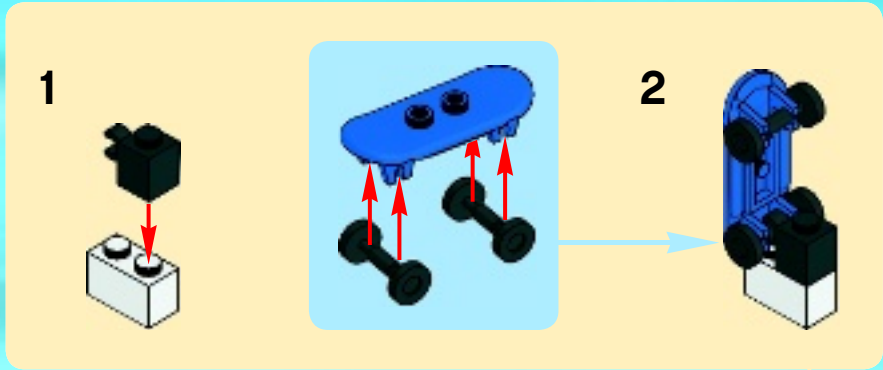

9

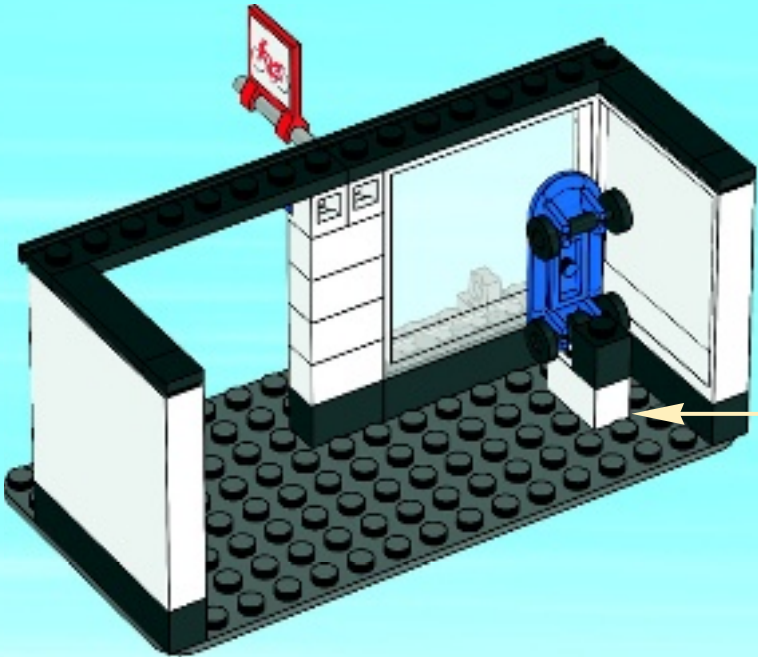

10

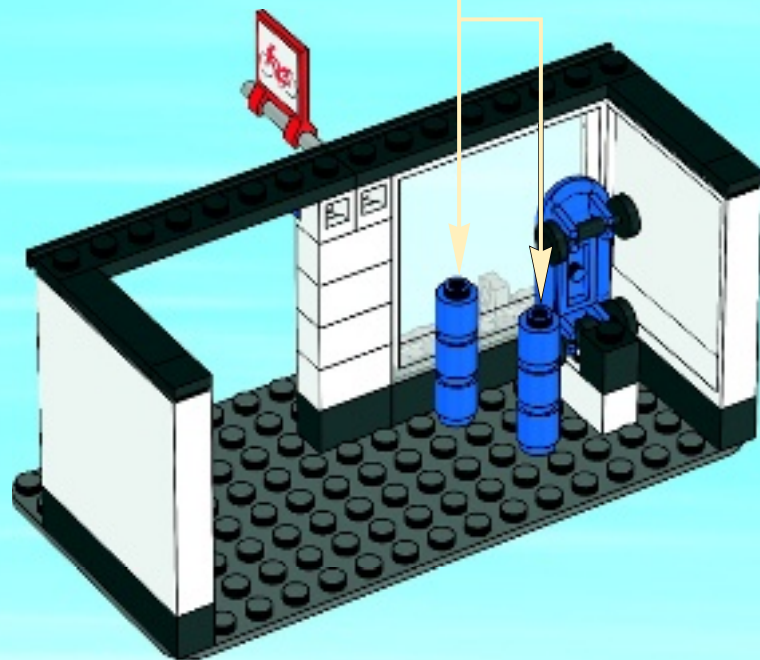
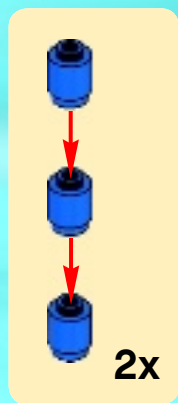

11

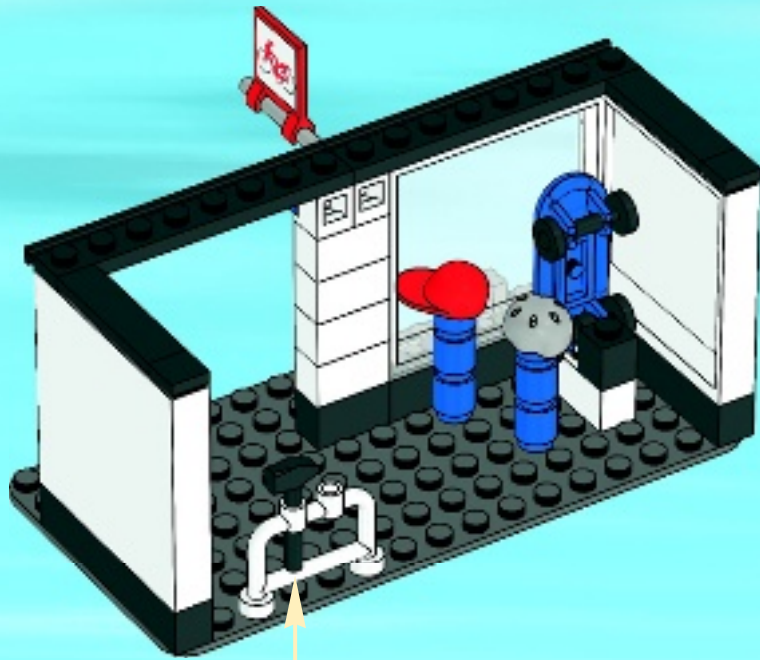

12

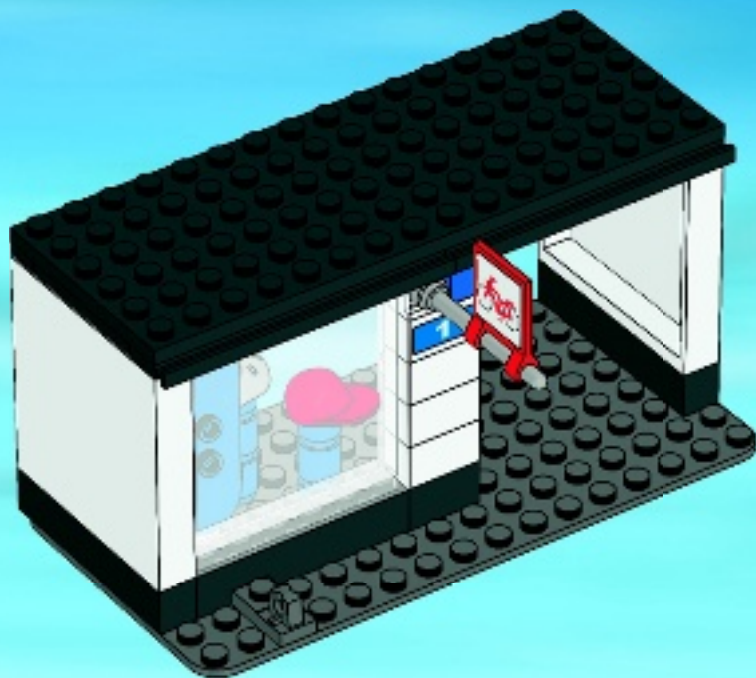

13

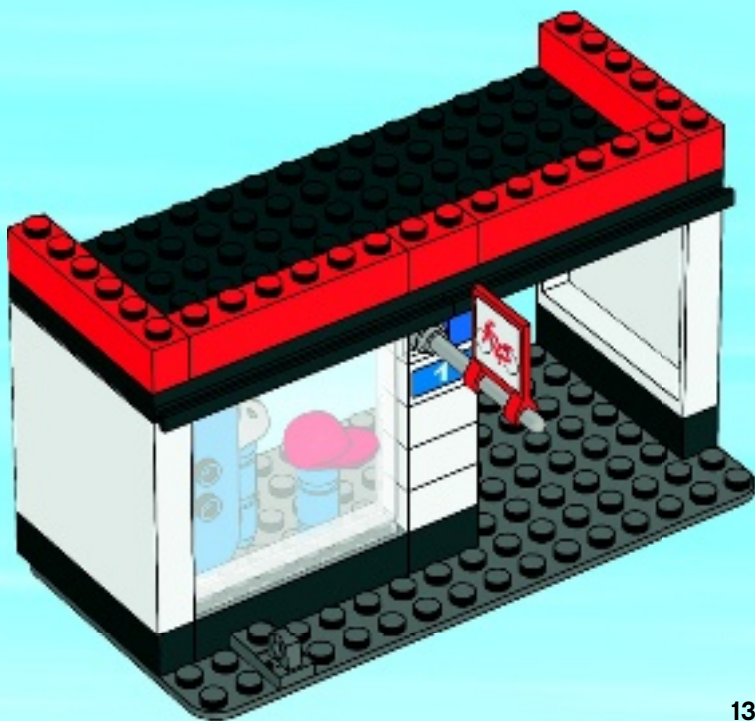

14



15

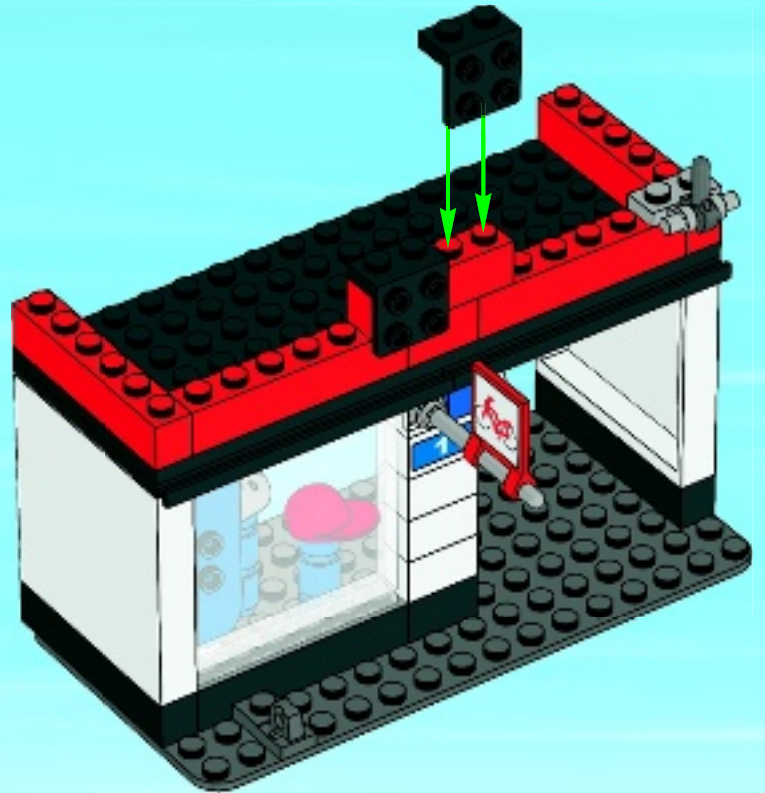

1



2



16

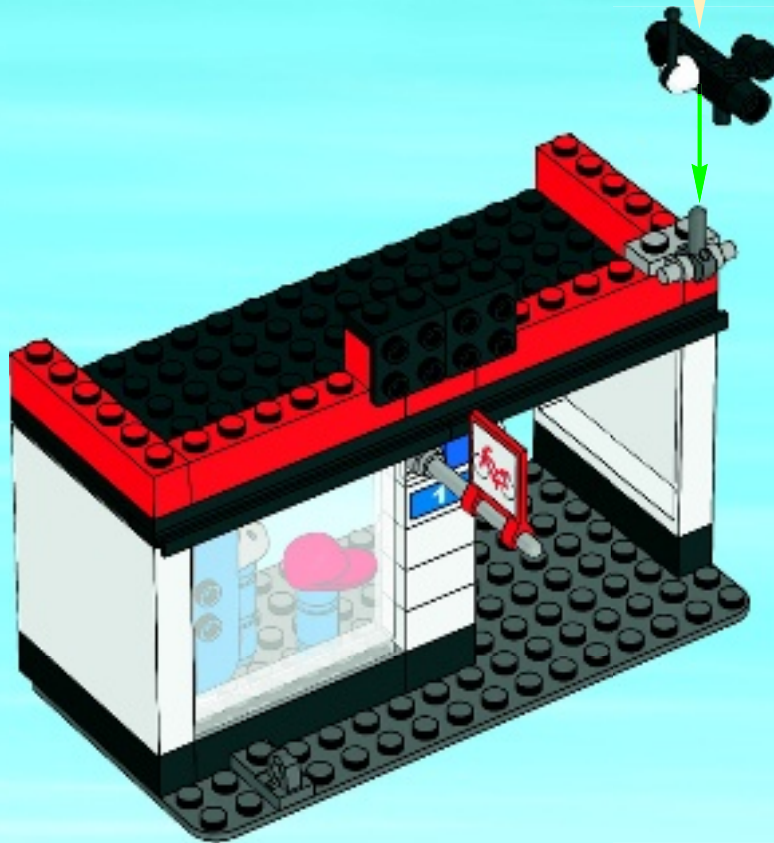

1

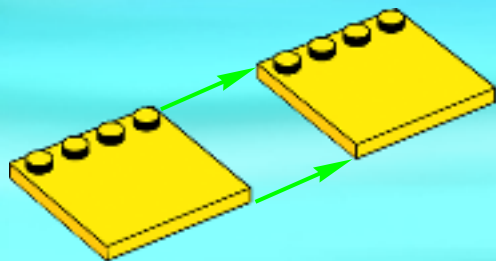

2

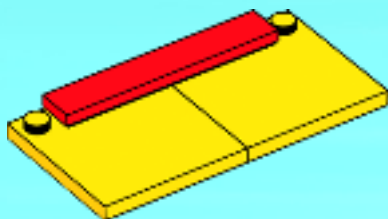

3

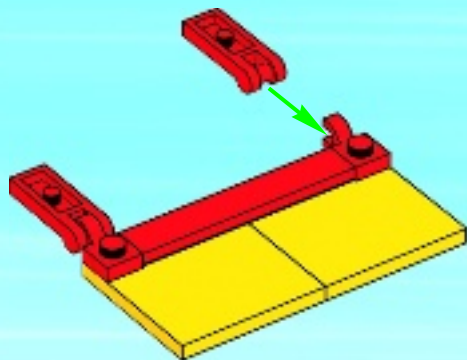

4

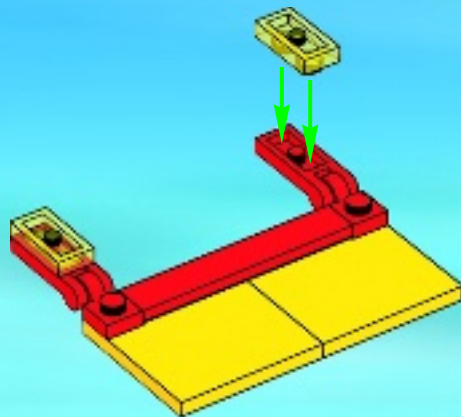

5

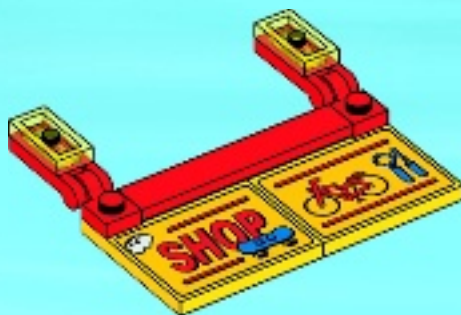

17



1

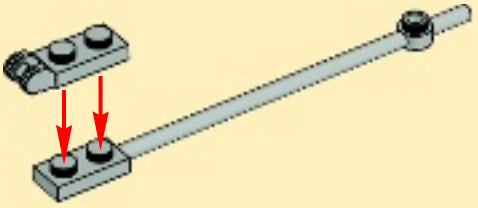

2

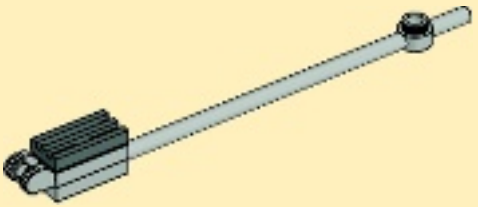

18



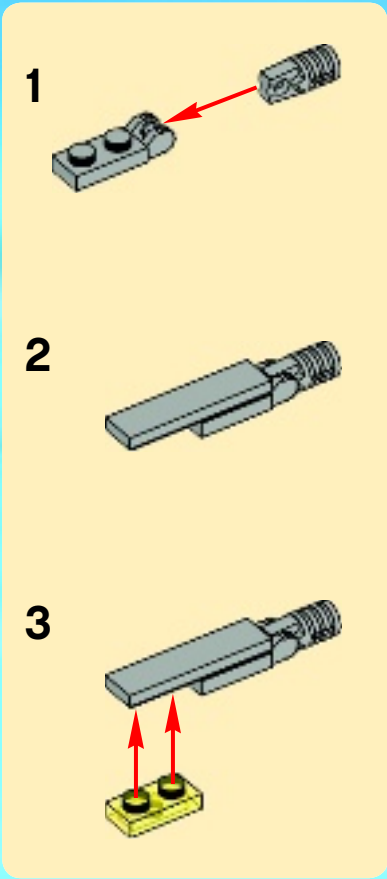

19



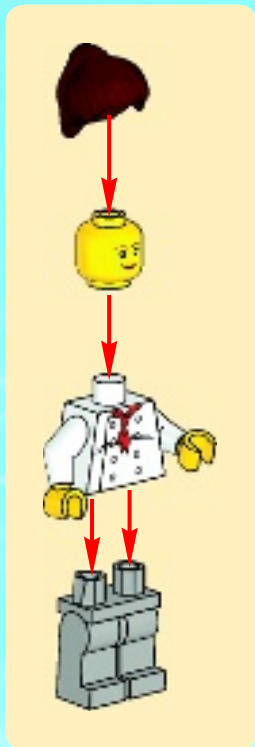

1

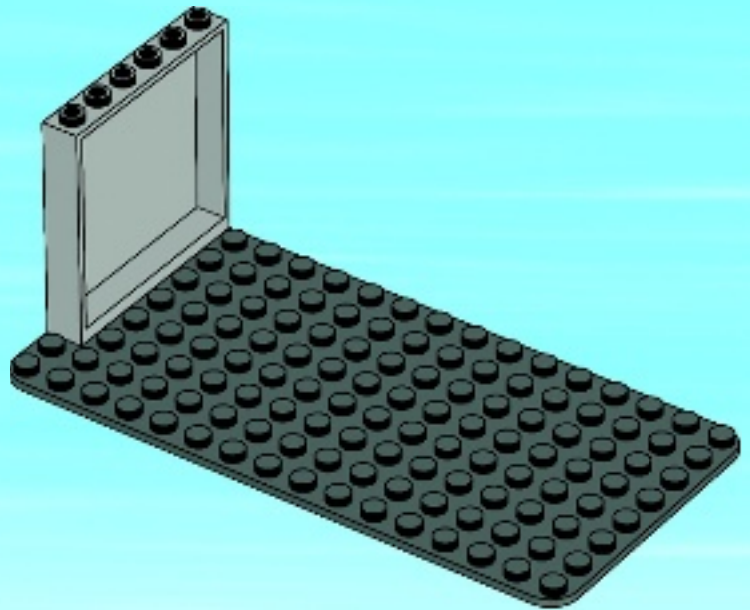

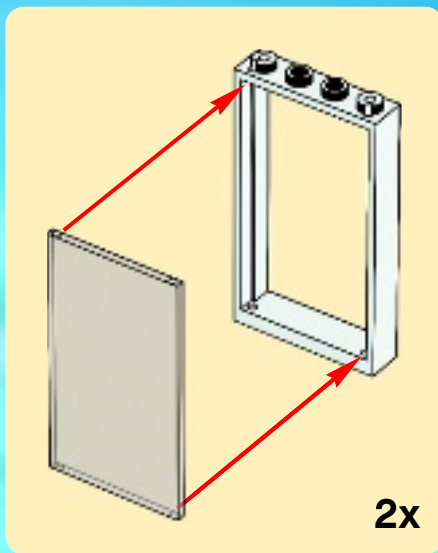

2

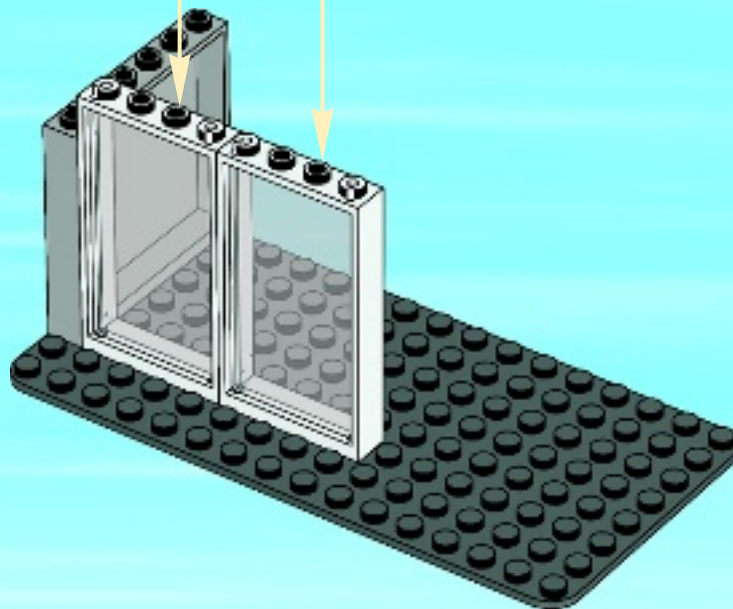

3

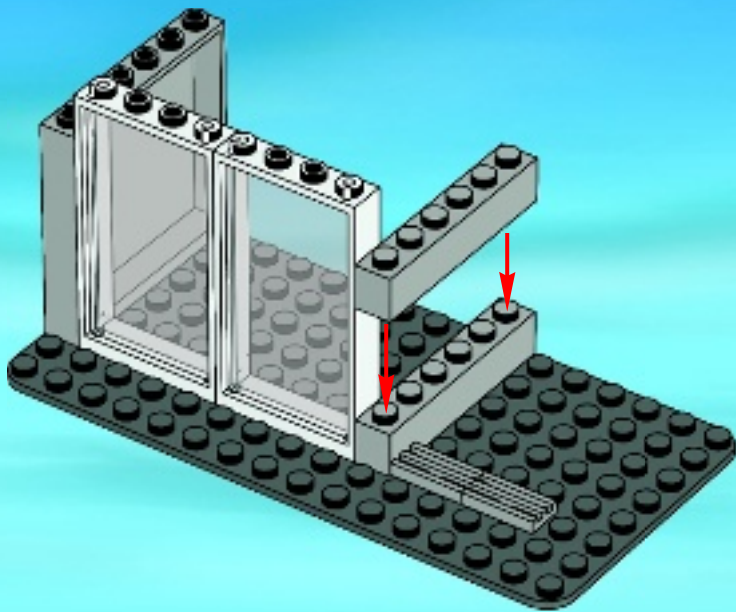

4

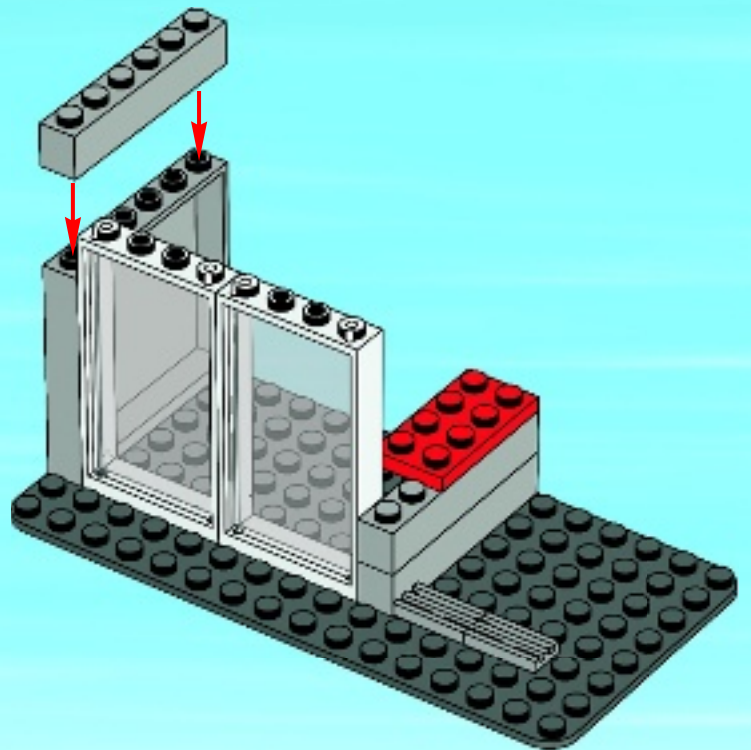

5

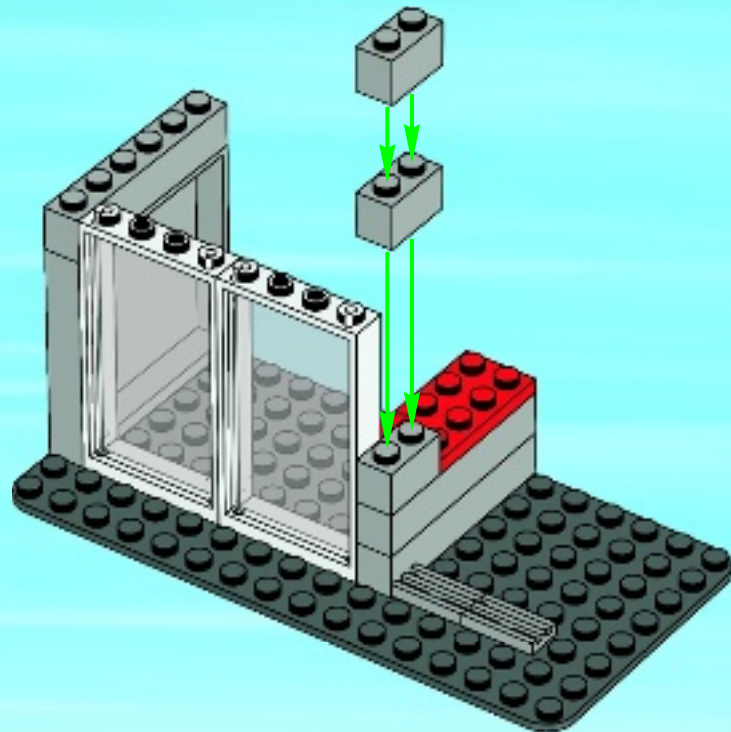

6

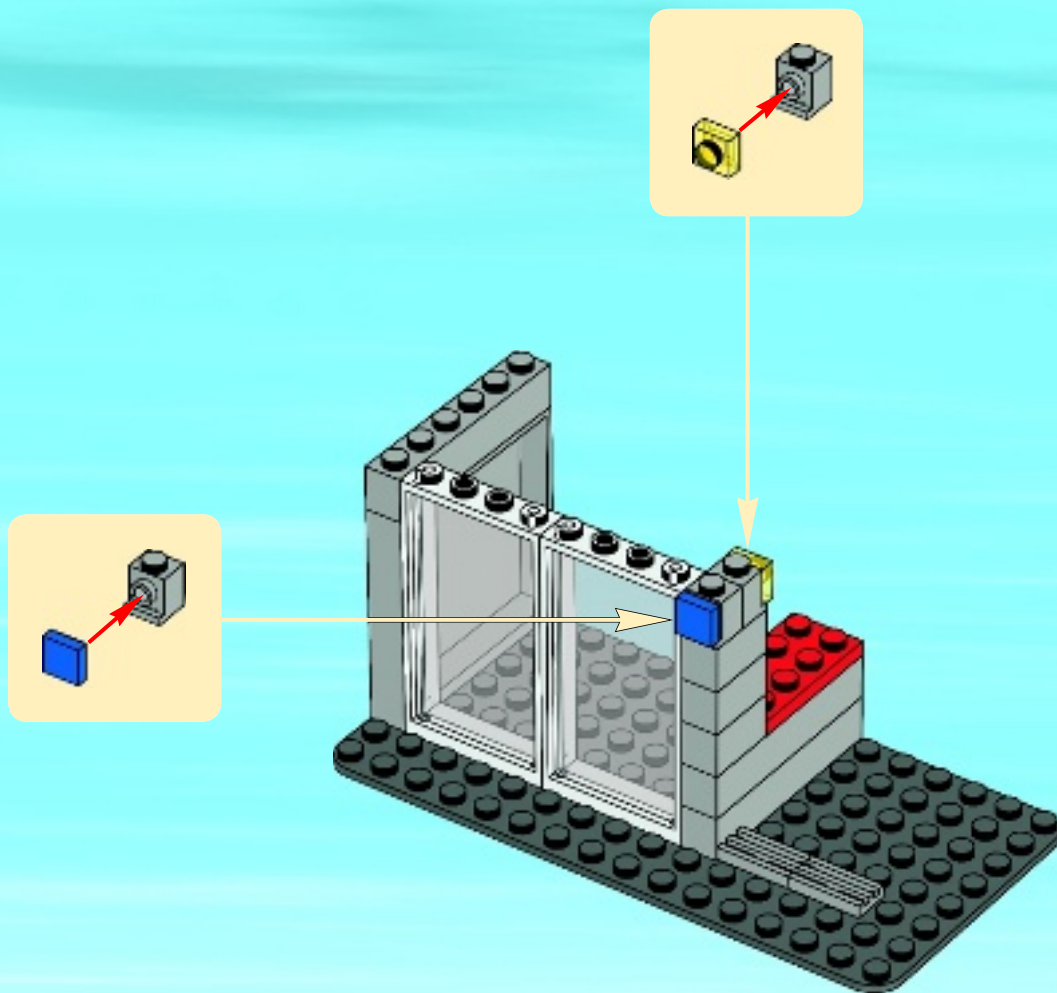

1

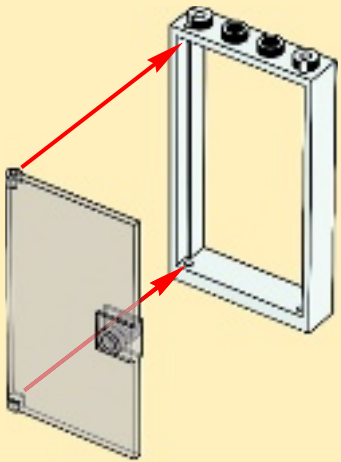

2

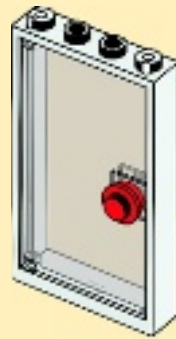

7

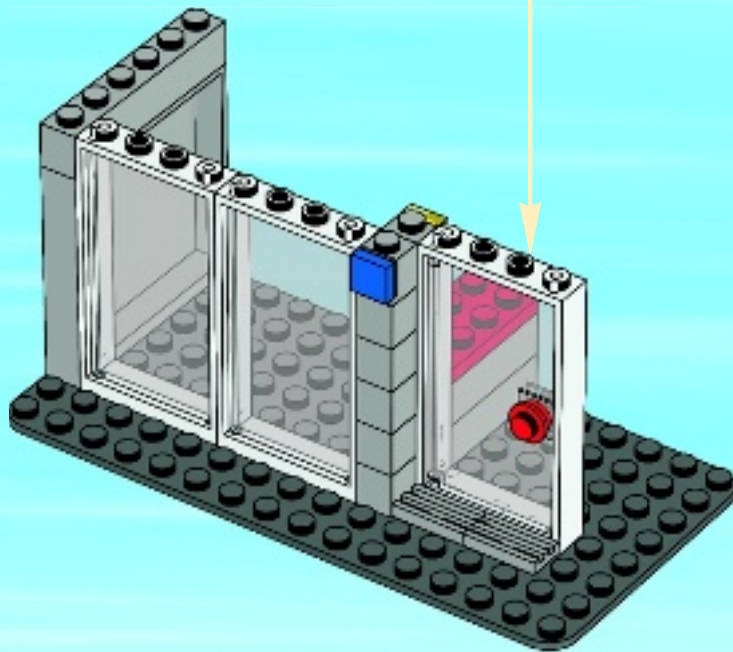

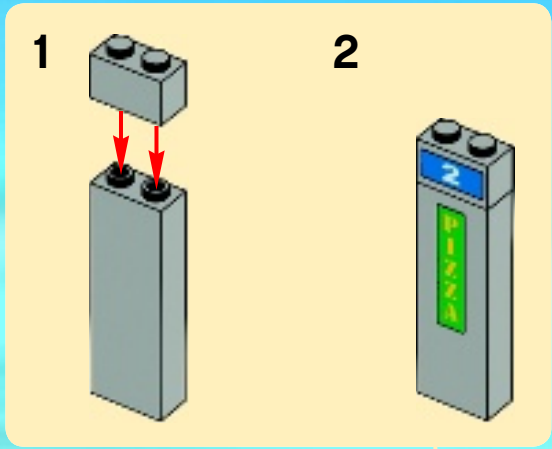

8

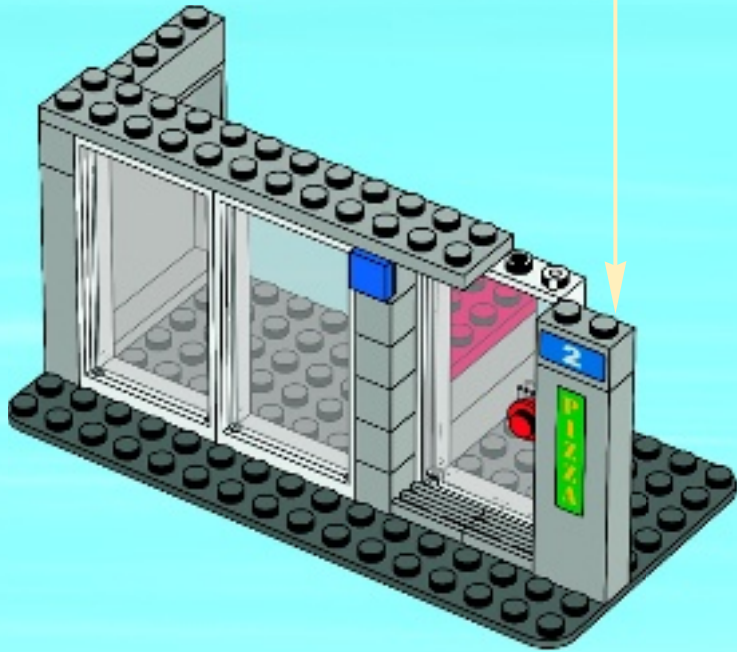

9

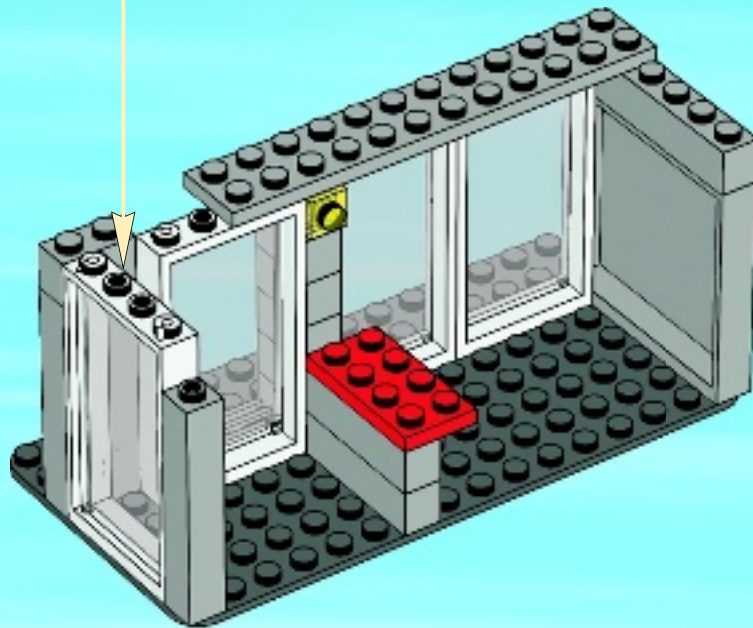
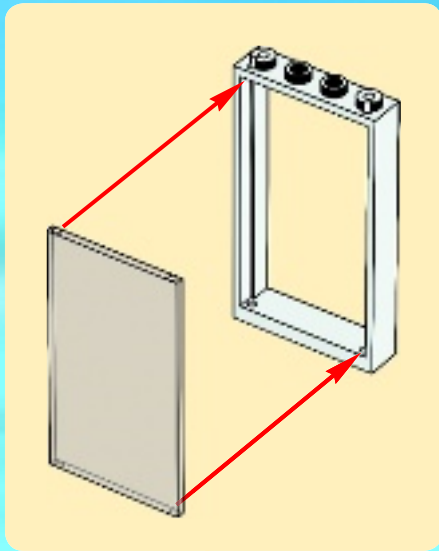

10

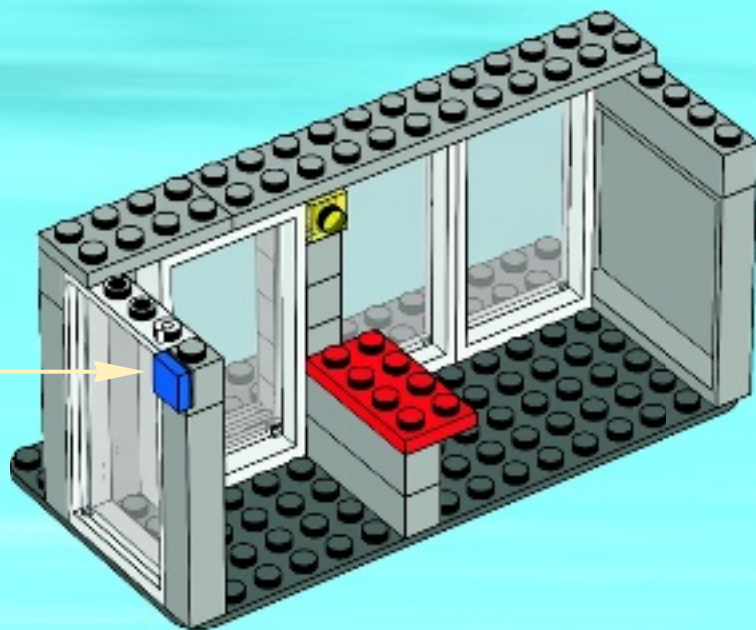
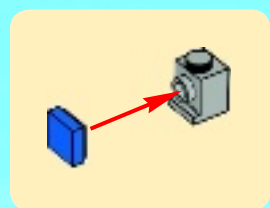

11

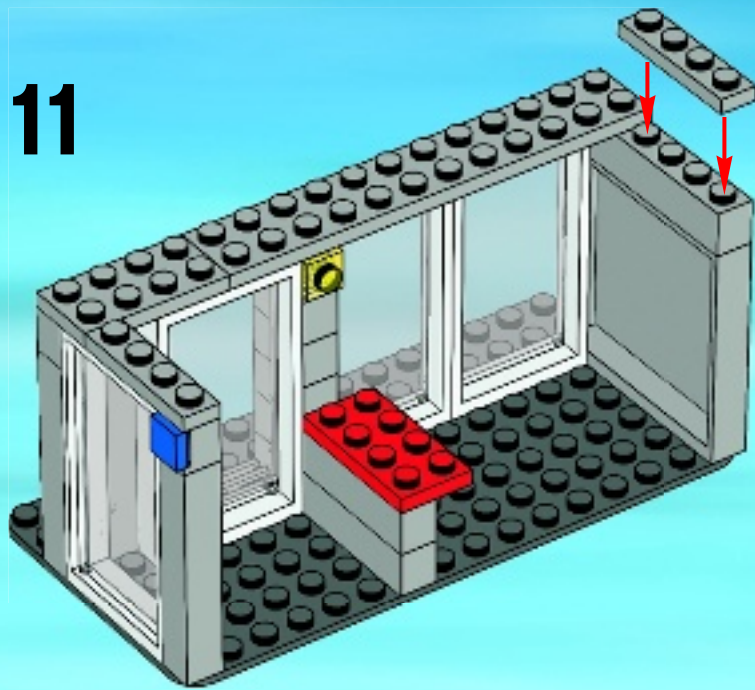

12

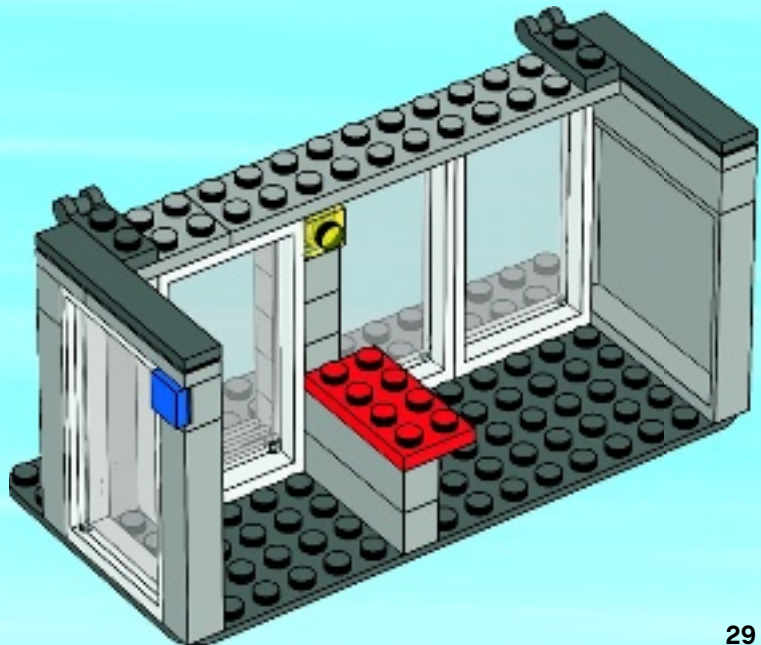

13

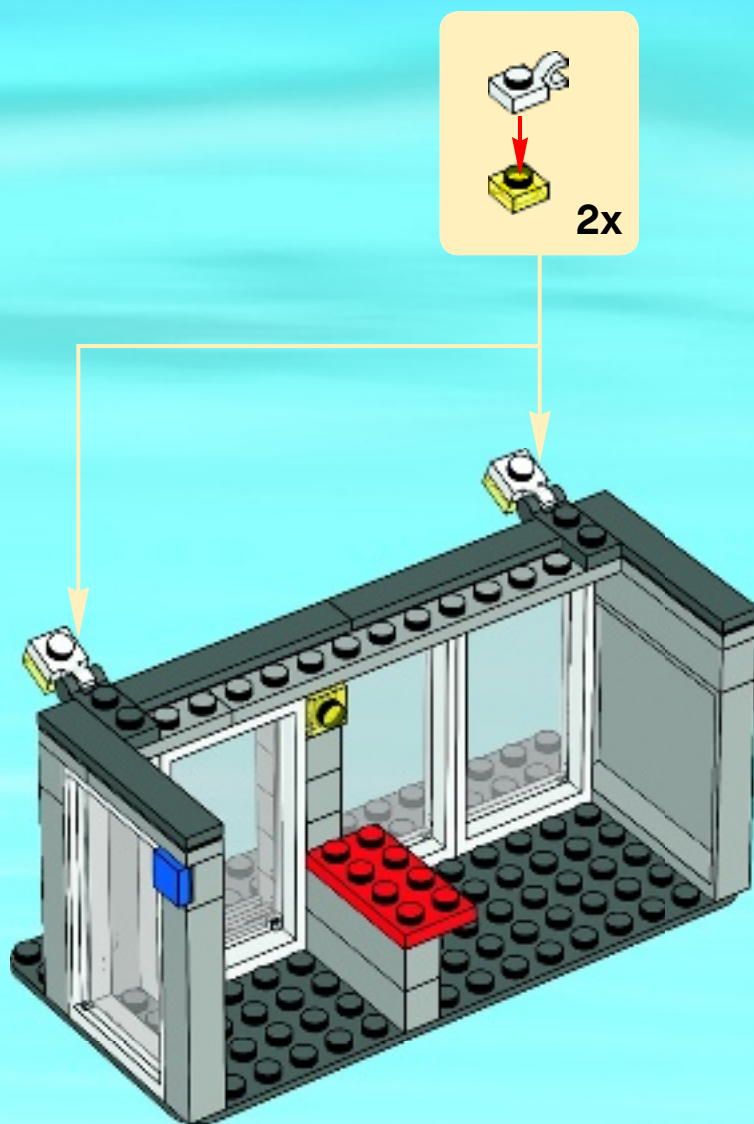



1

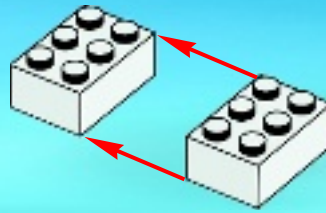

2



3

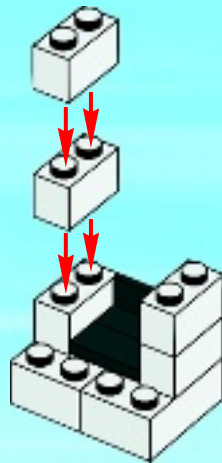

4

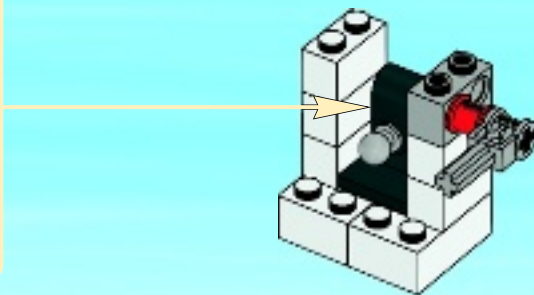
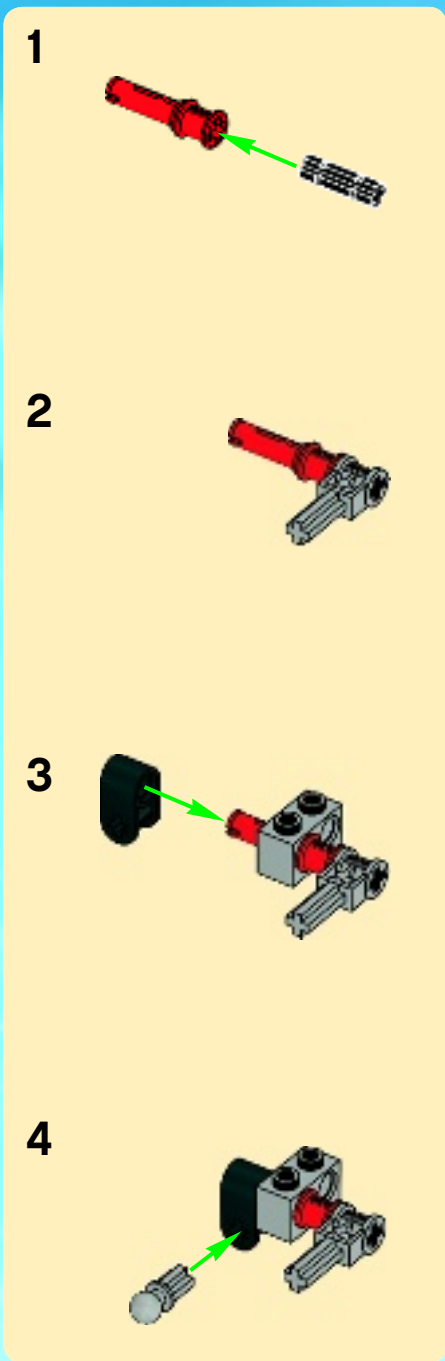

5

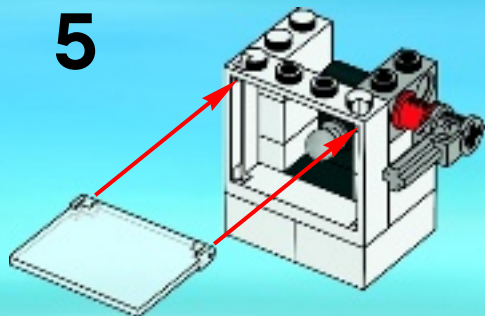

6

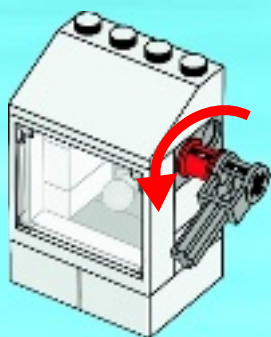

7

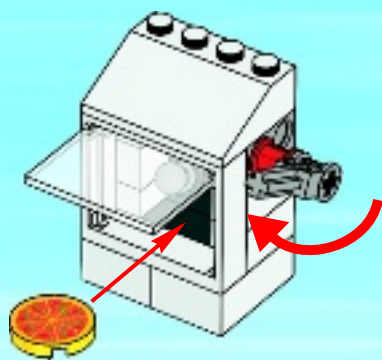

14

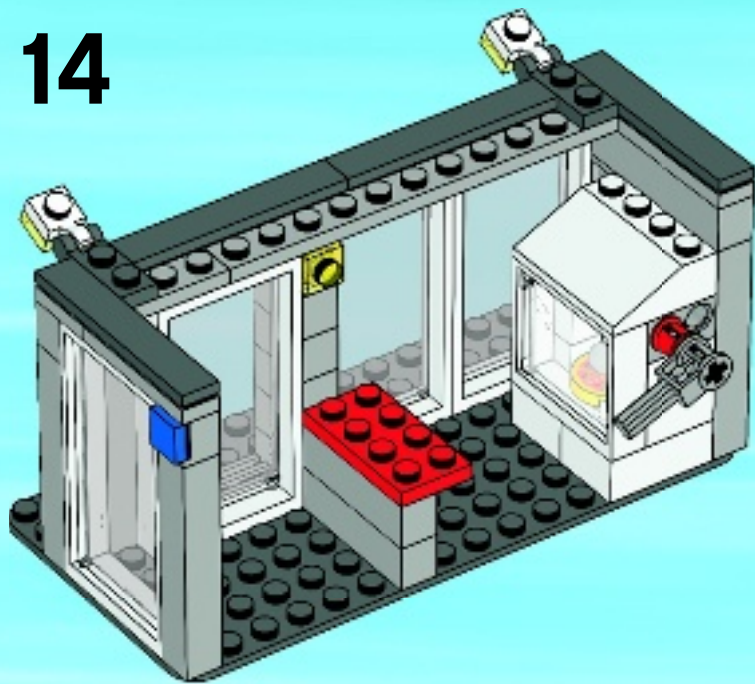

15

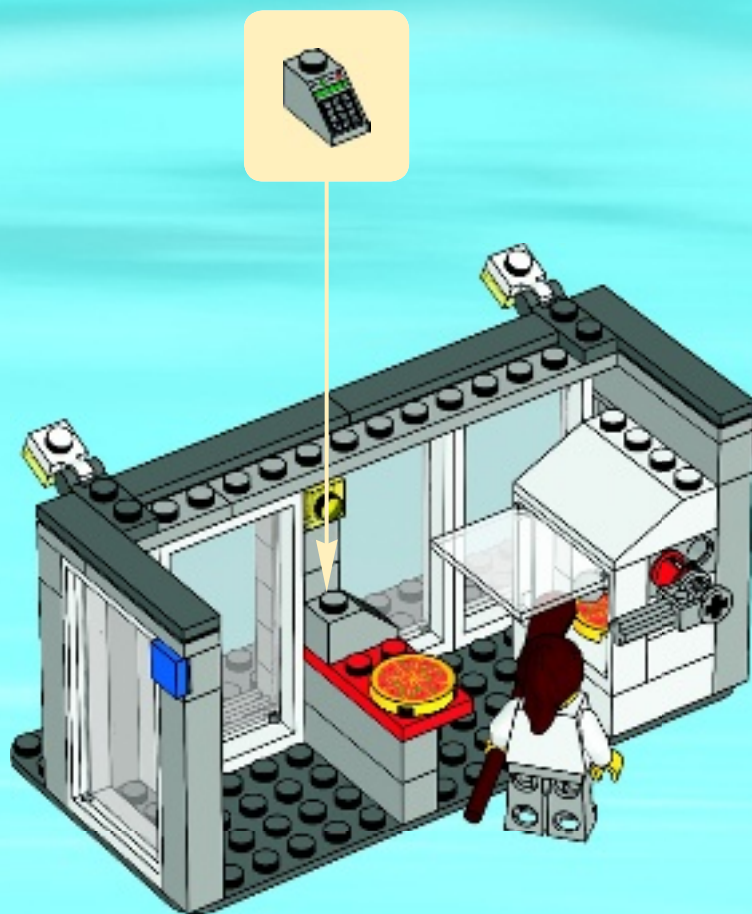

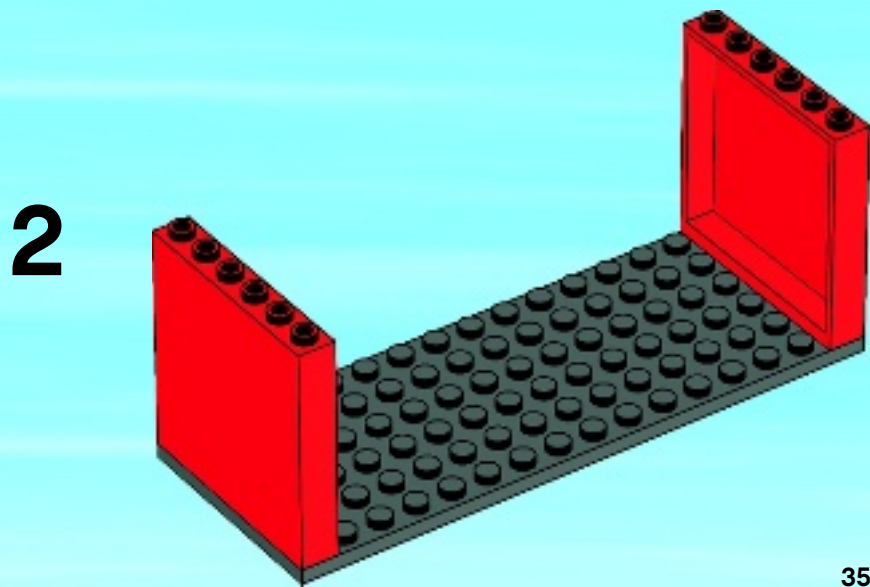
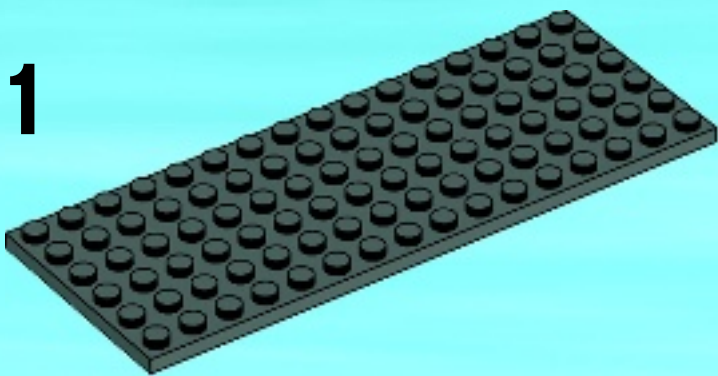

3

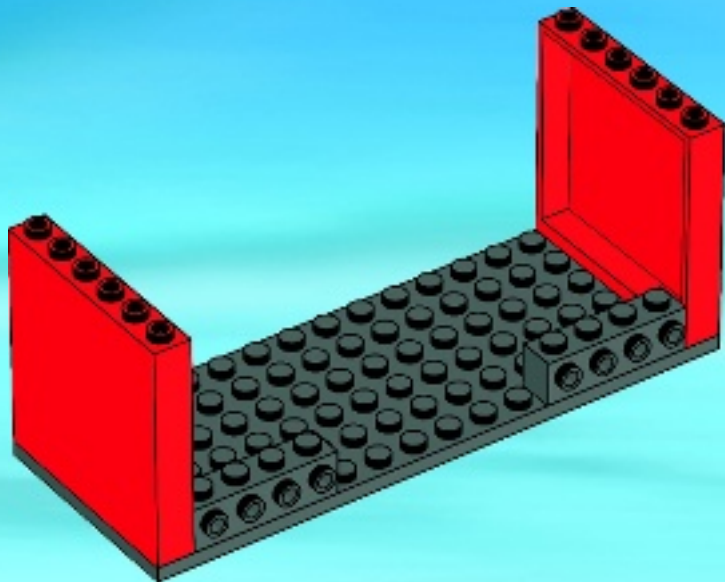

4

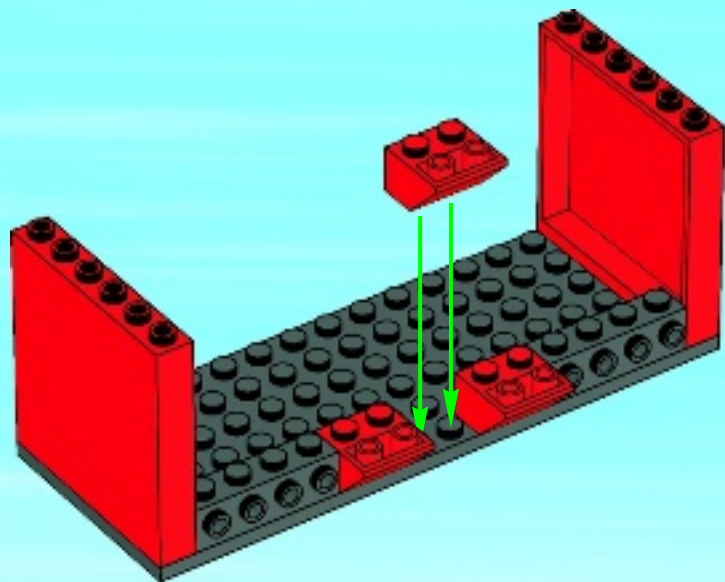

5

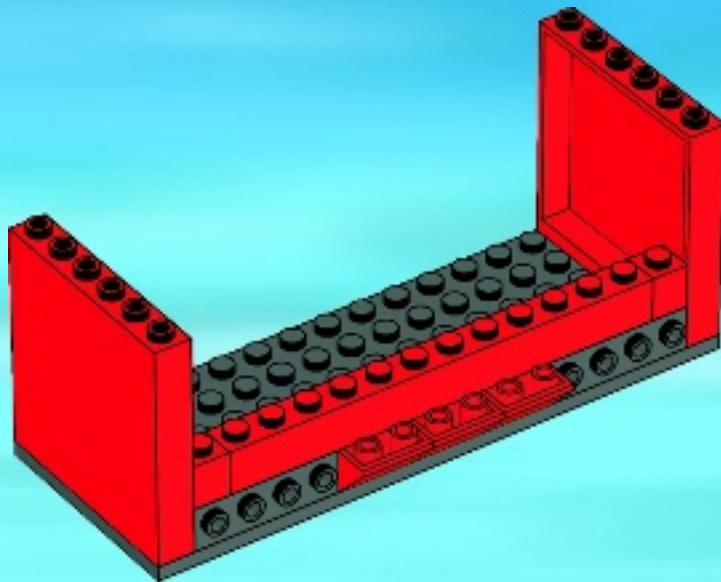

6

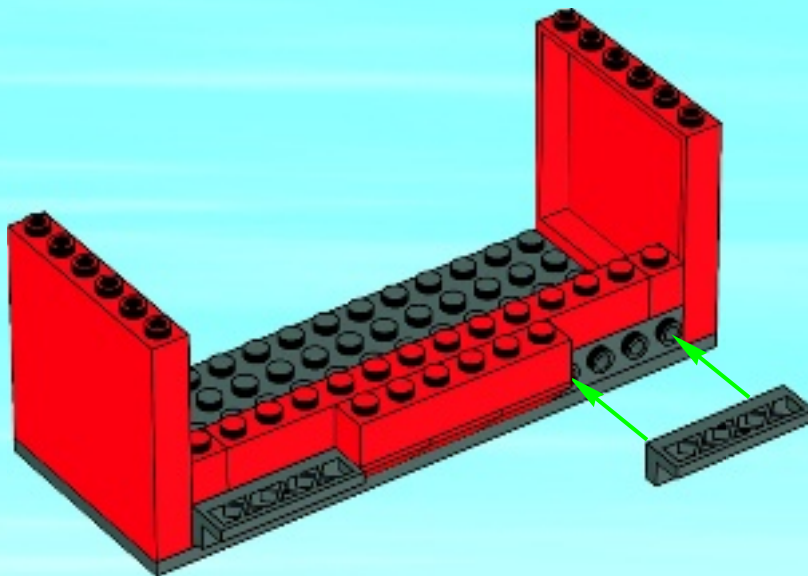

7

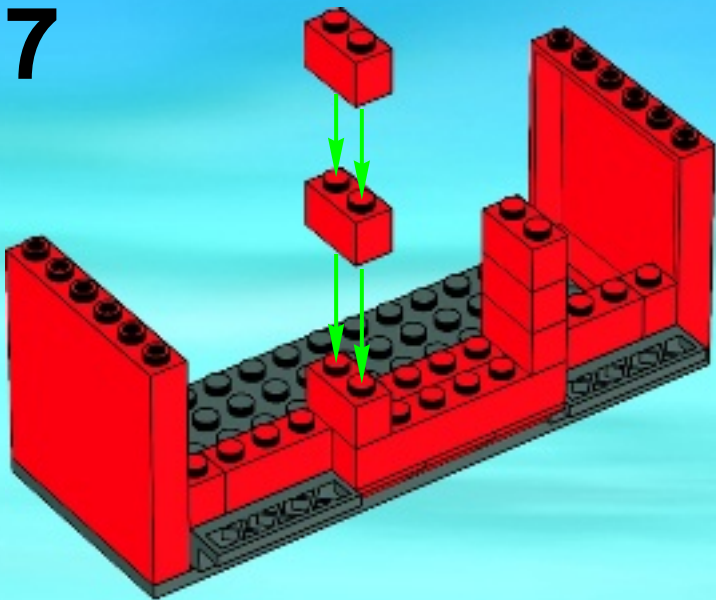

1

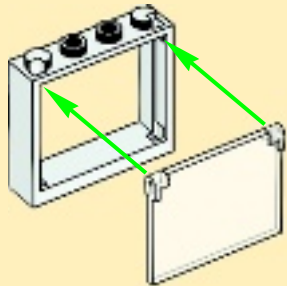

2



3x

8

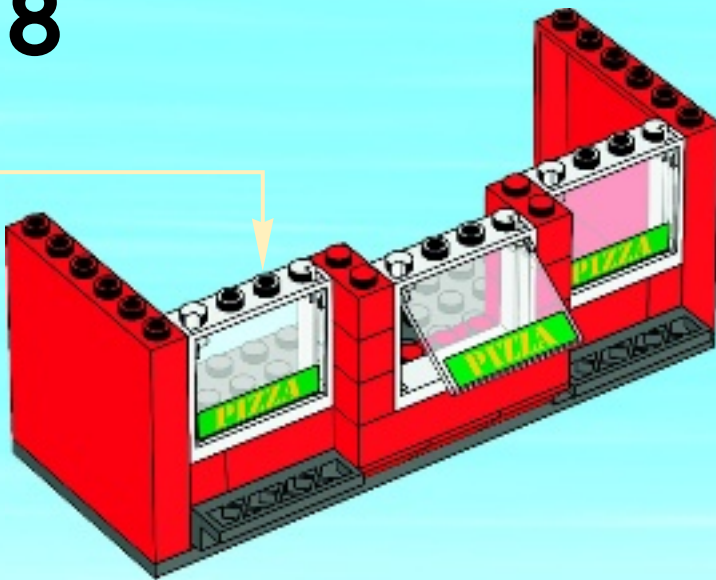

9

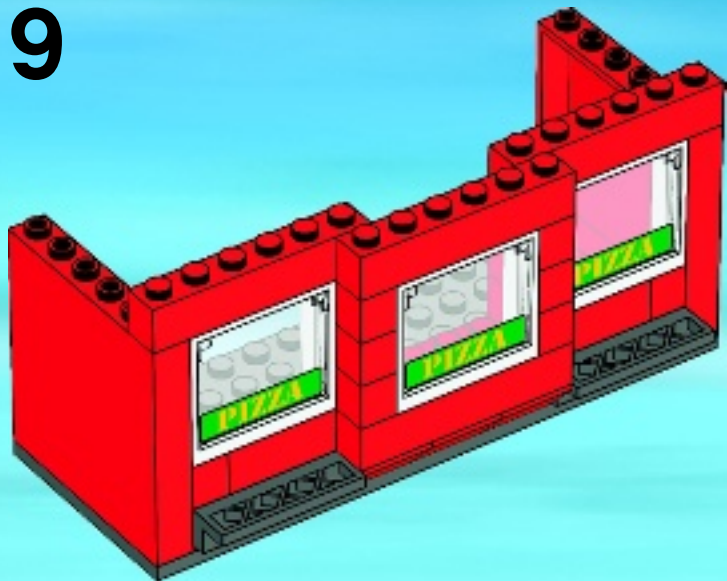

10

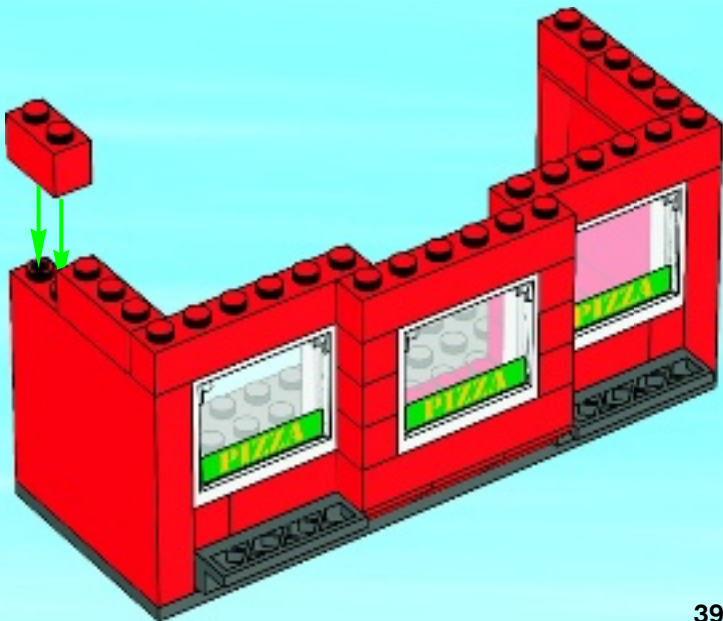

11

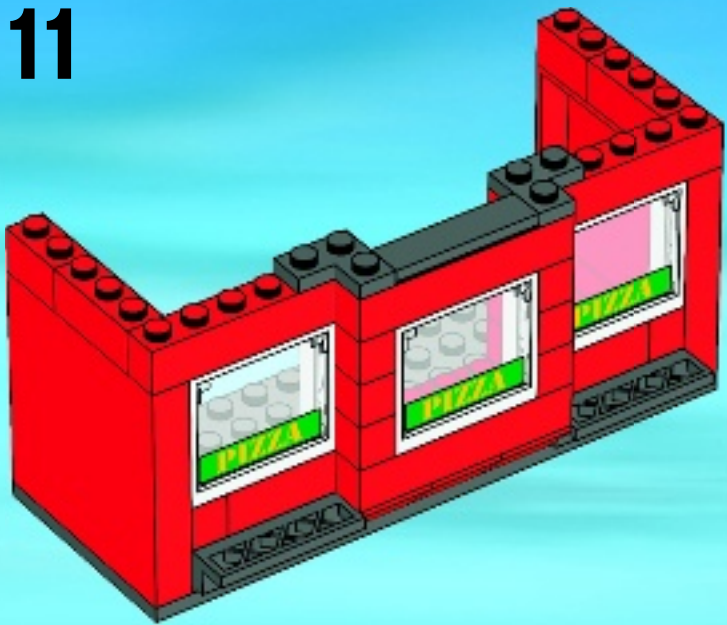

12

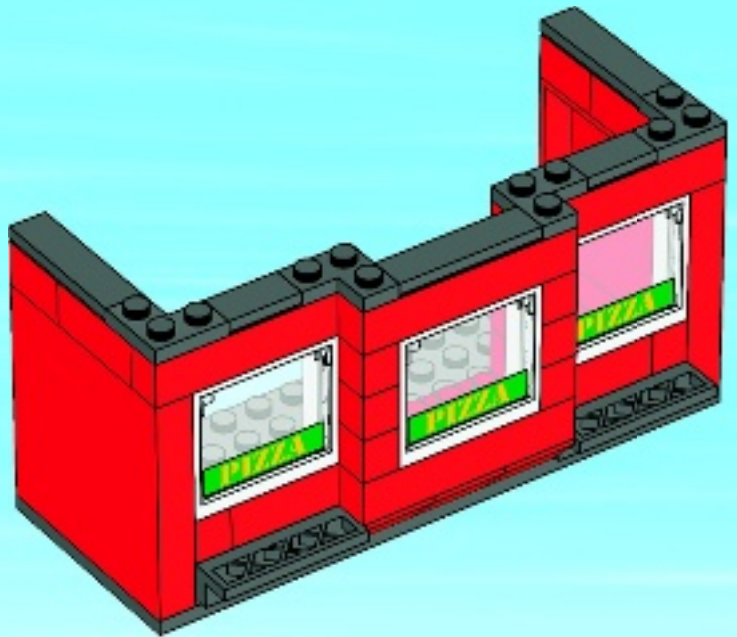

13

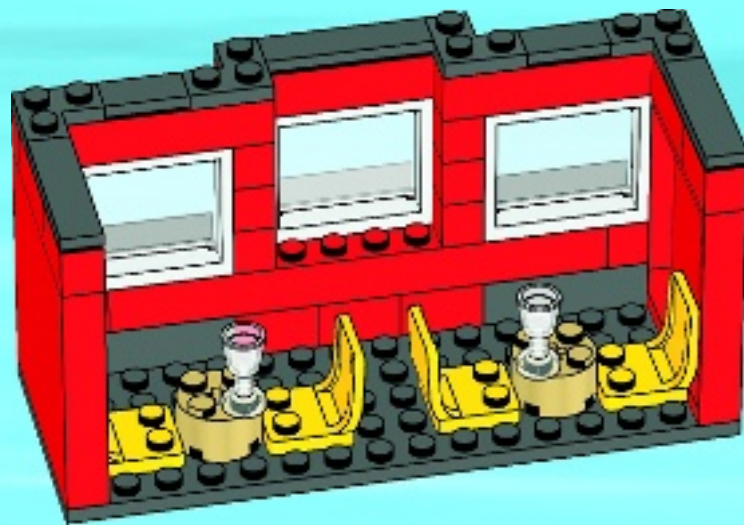

14





1

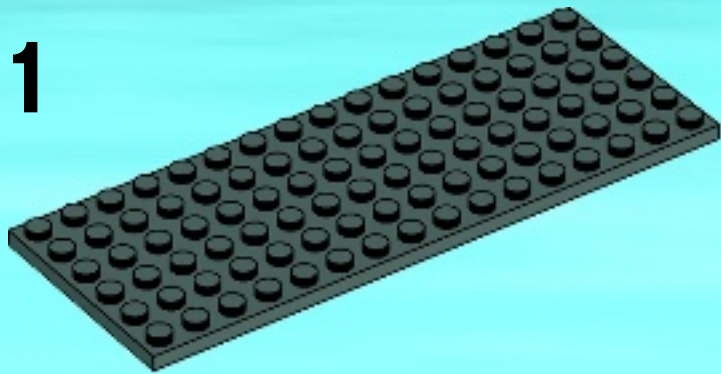

2

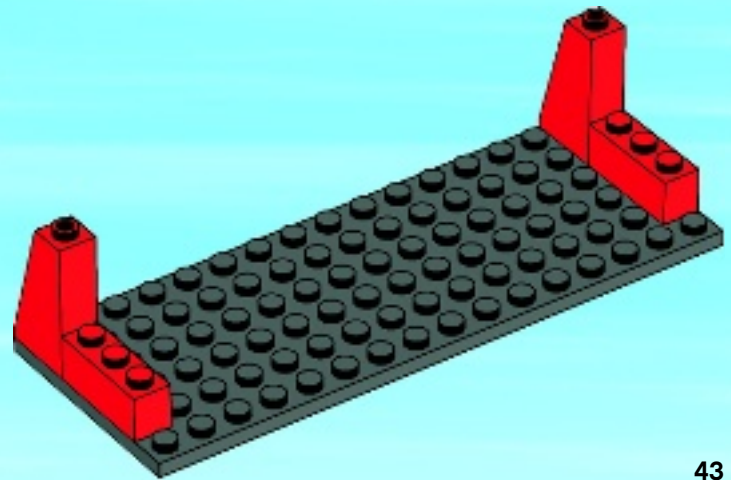

3

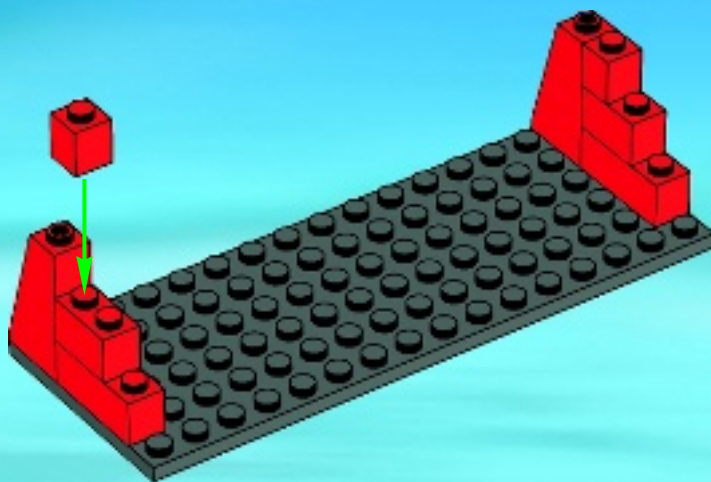

4

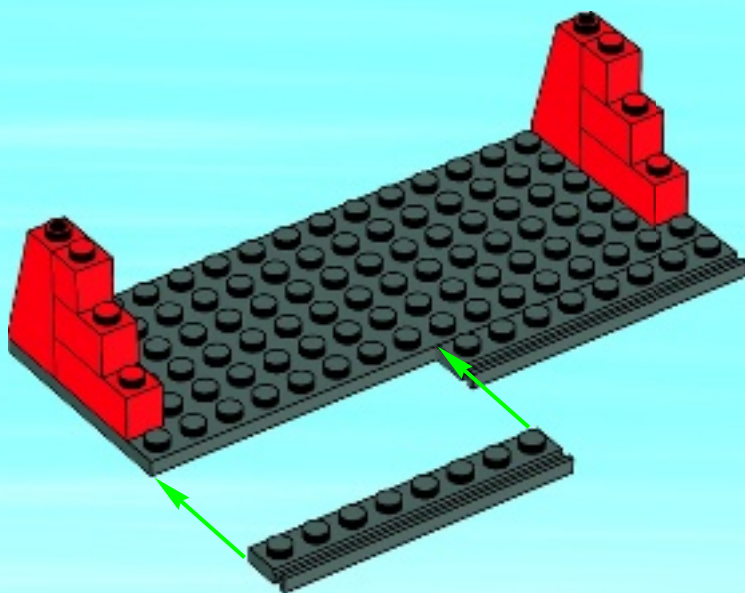

5



6

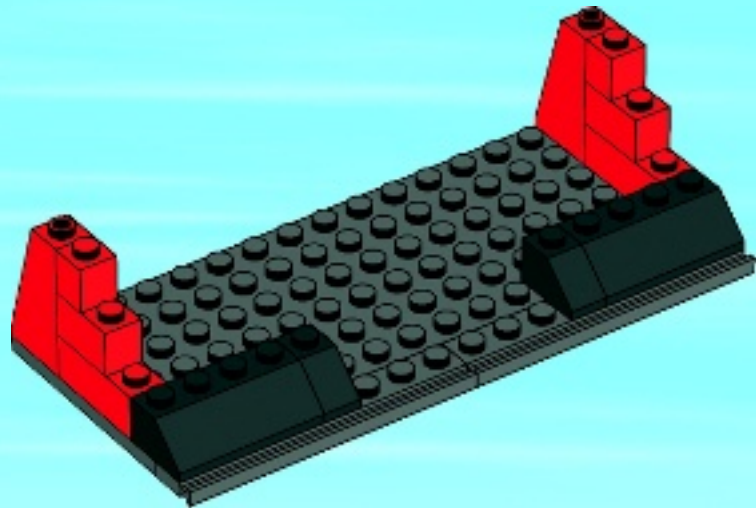

7



8



9

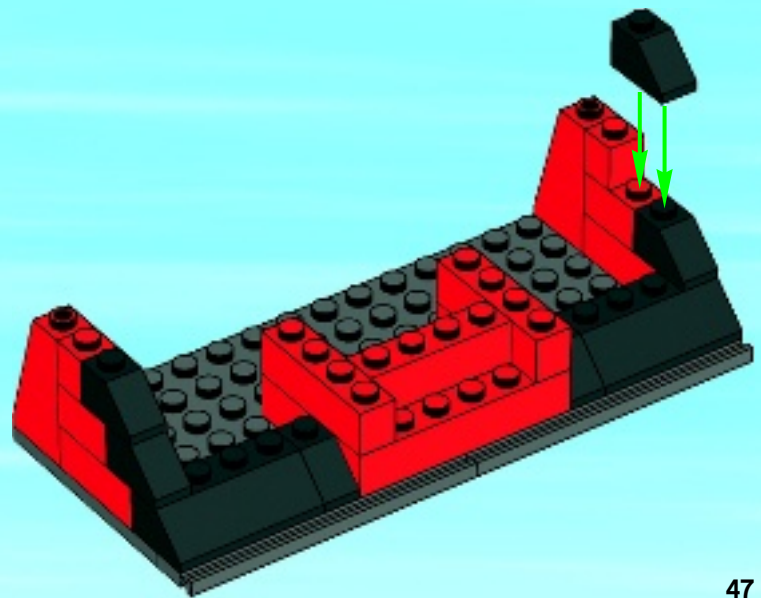

10

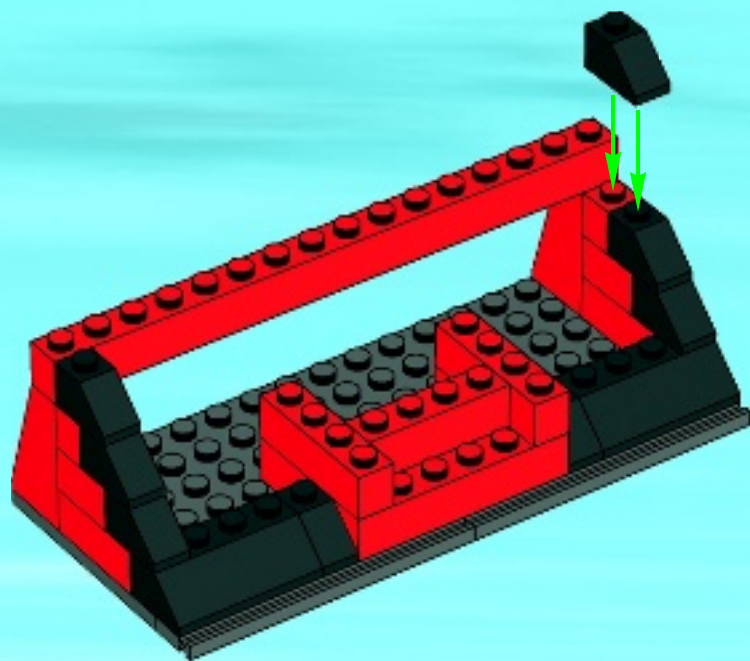

11

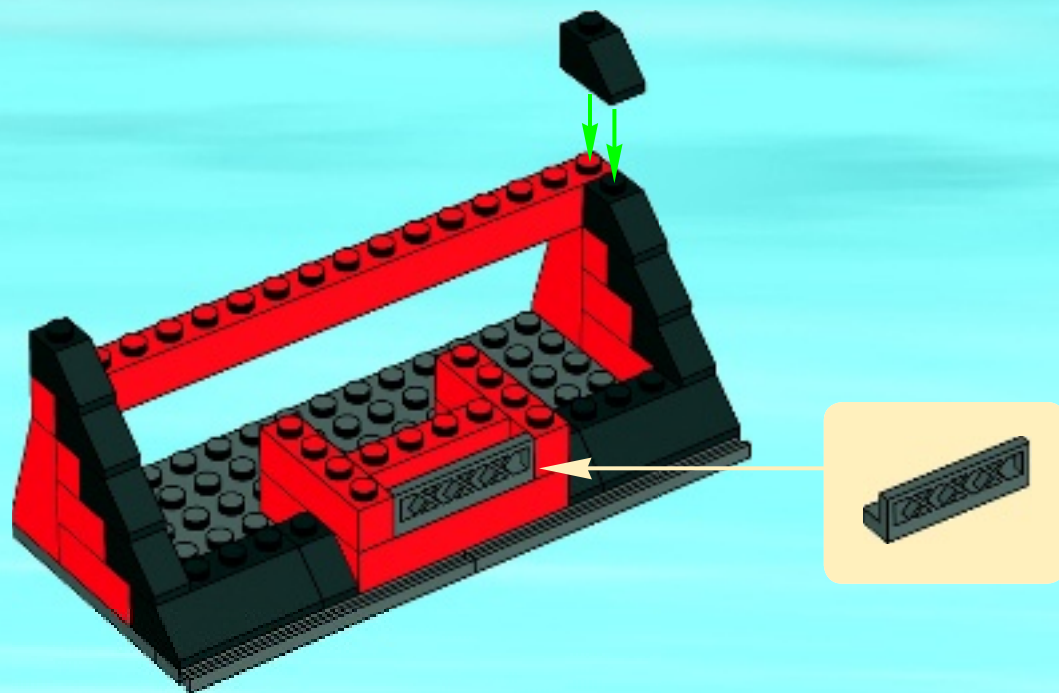

12

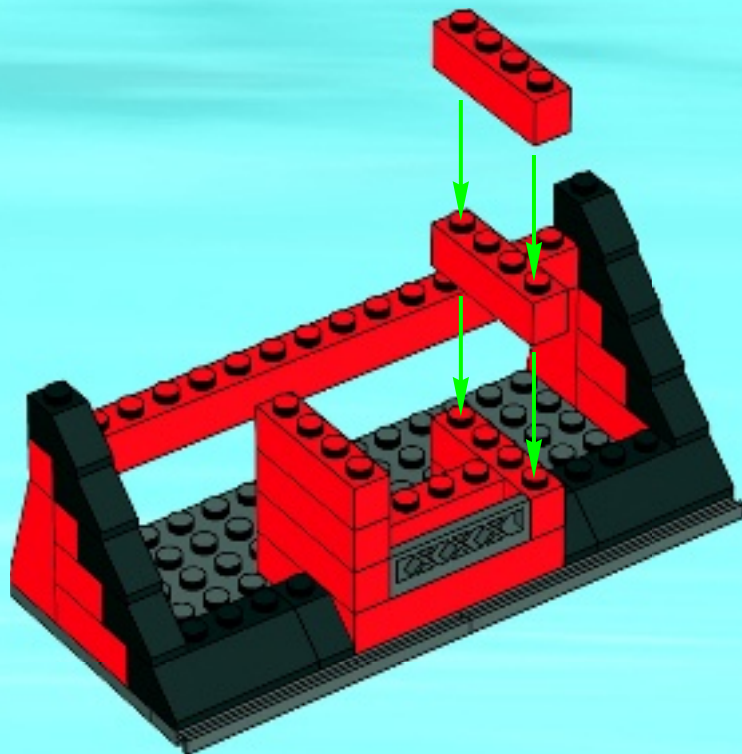

13

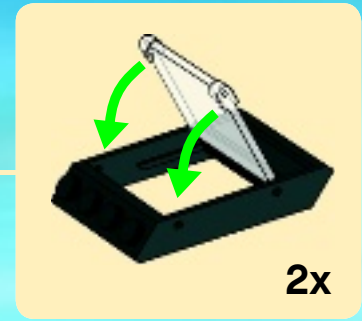
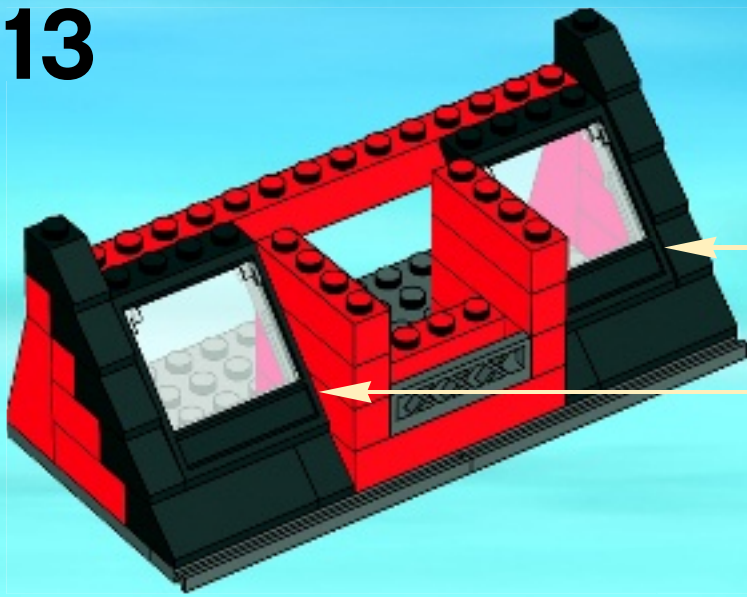

14

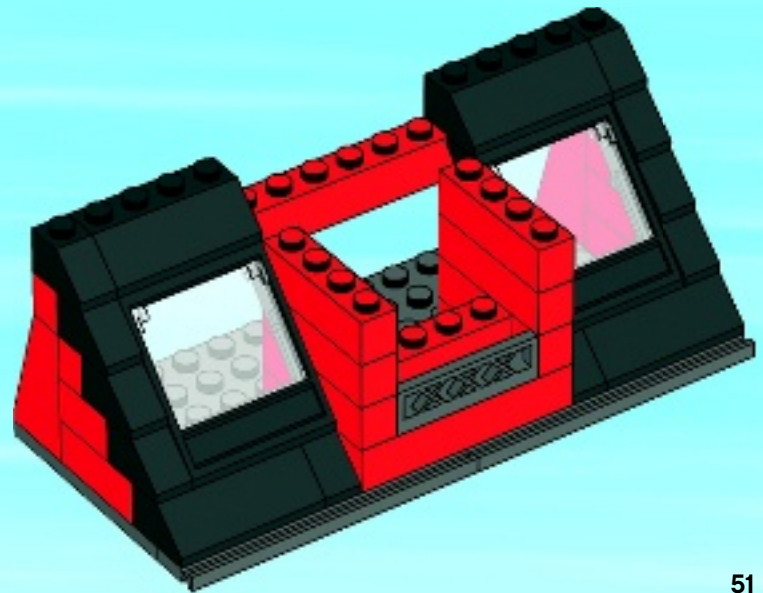

15

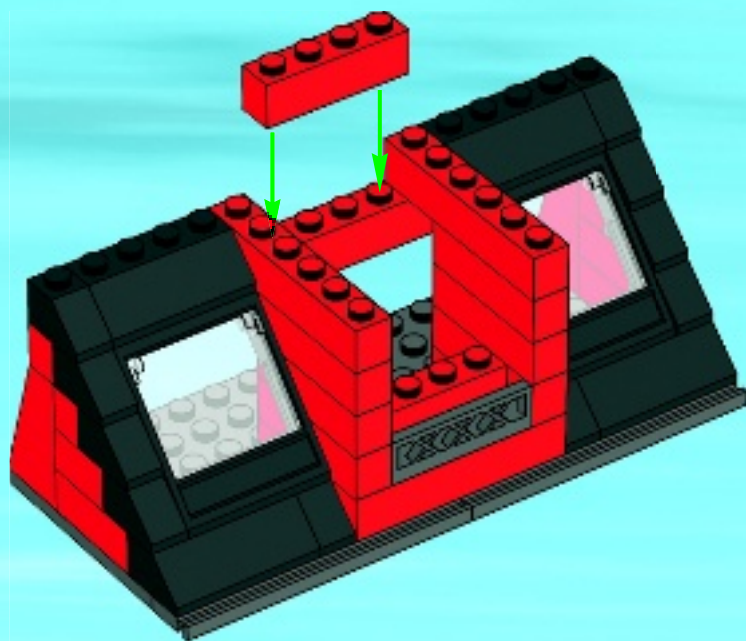

16

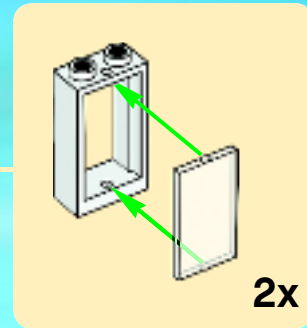
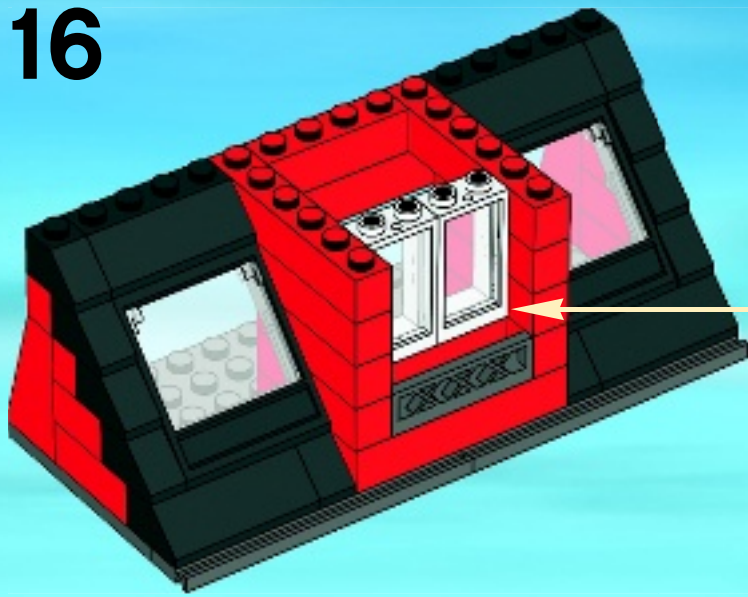

17

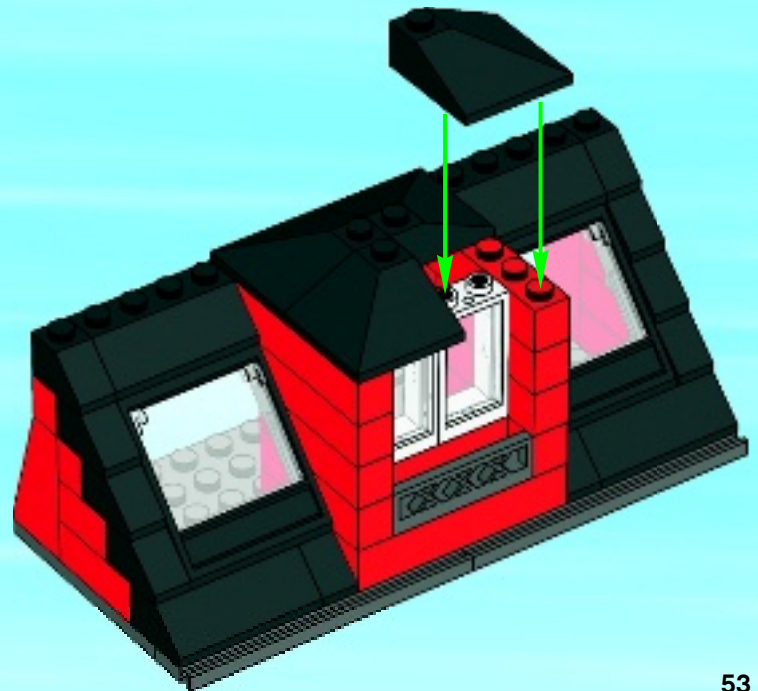

18

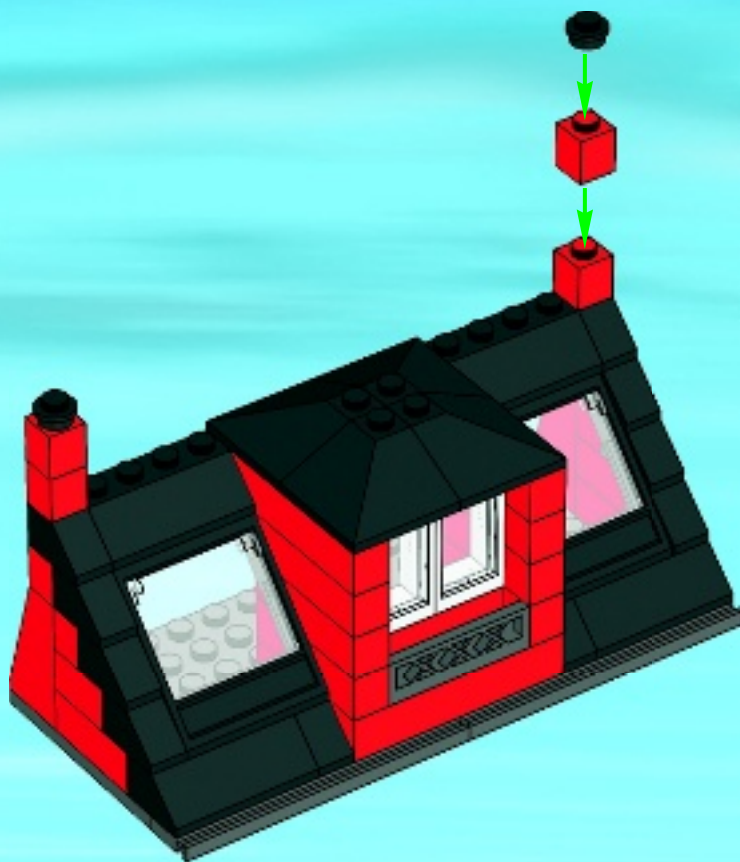

19



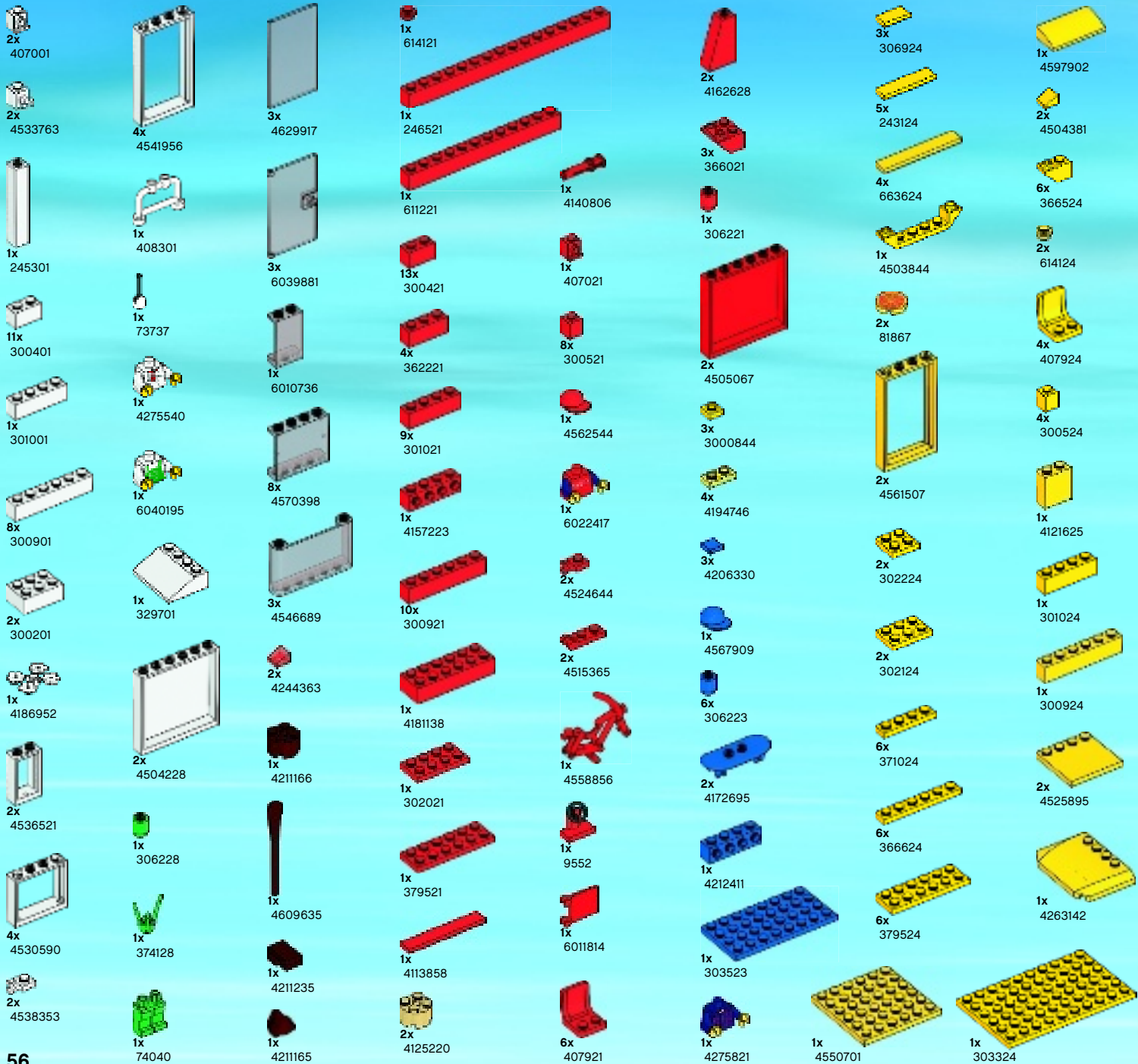

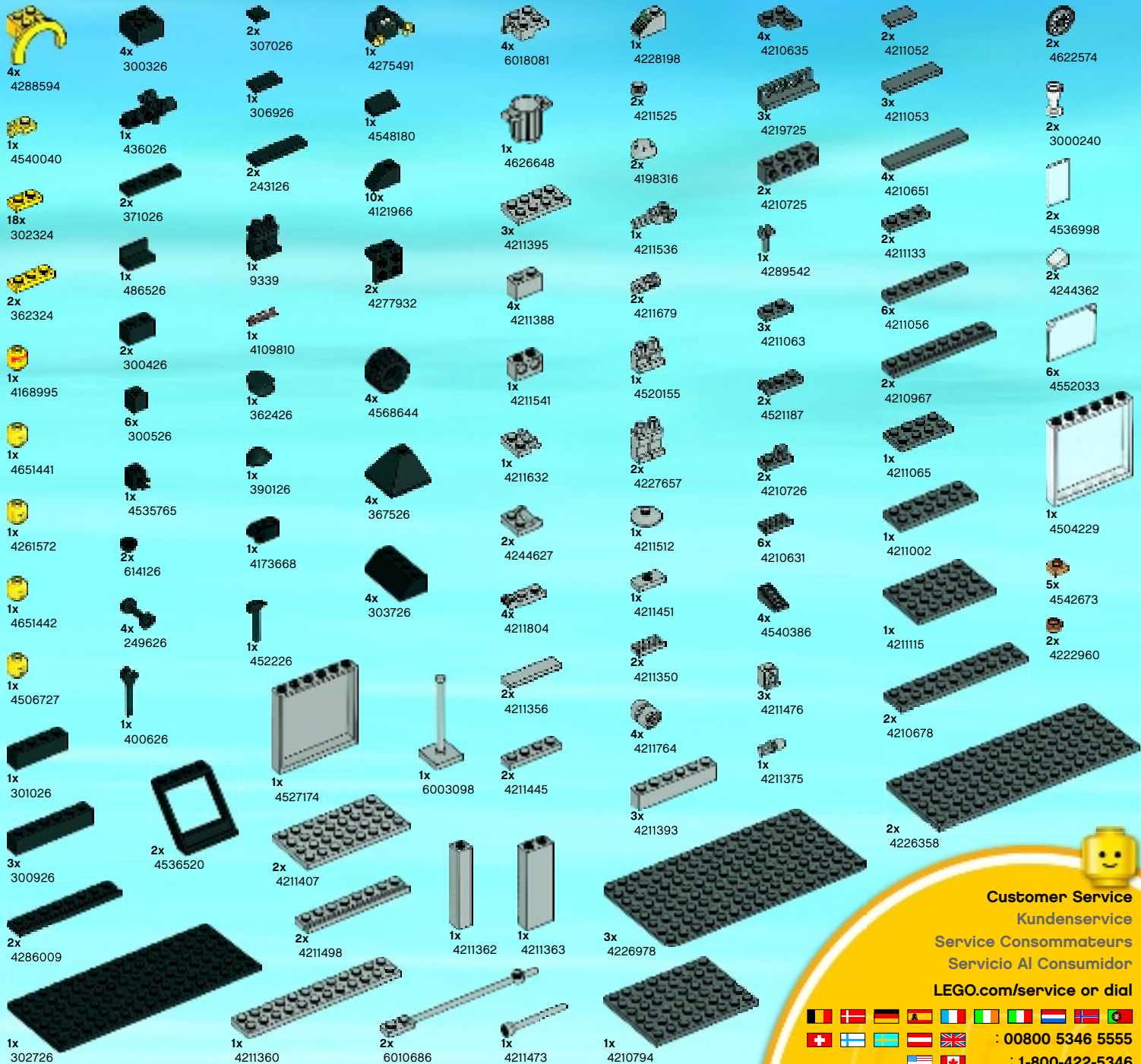

Customer Service
Kundenservice
Service Consommateurs
Servicio Al Consumidor
LEGO.com/service or dial

: 00800 5346 5555
: 1-800-422-5346



CITY



4431



4432



4433



4434



4435

1



2



3



www.LEGOclub.com/Max



club

FREE*! GRATIS! GRATUIT!

*Paid subscription in Australia and New Zealand.
*Abonnement payant en Australie et Nouvelle-Zélande.



WIN!

Go to www.LEGOsurvey.com/product to fill out a survey for a chance to win a cool LEGO® Product.

No purchase necessary.

Open to all residents where not prohibited.



LEGO.com



www.LEGOsurvey.com/product

GEWINNE! WIN!

Nimm an der Umfrage auf www.LEGOsurvey.com/product teil und hab die Chance ein cooles LEGO® Produkt zu gewinnen!

Die Teilnahme am Gewinnspiel führt zu keinerlei Kaufverpflichtungen. Teilnahme in allen nicht ausgeschlossenen Ländern möglich.

Ga naar www.LEGOsurvey.com/product, vul een enquêteformulier in en maak kans op een cool LEGO® product.

Geen aankoopverplichting. Iedereen mag deelnemen, uitgezonderd ingezetenden van landen waar een enquêteverbod geldt.

GAGNE! 当てよう!

Visite www.LEGOsurvey.com/product pour répondre à un questionnaire et avoir une chance de gagner un produit LEGO® très cool!

Aucune obligation d'achat. Ouvert à tous les résidents des pays autorisés.

www.LEGOsurvey.com/product にアクセスして、アンケートにご記入ください。当選者にはレゴ®製品を差し上げます。

お買い上げの必要はありません。

禁止されていない限り、すべての皆様にご利用いただけます。