

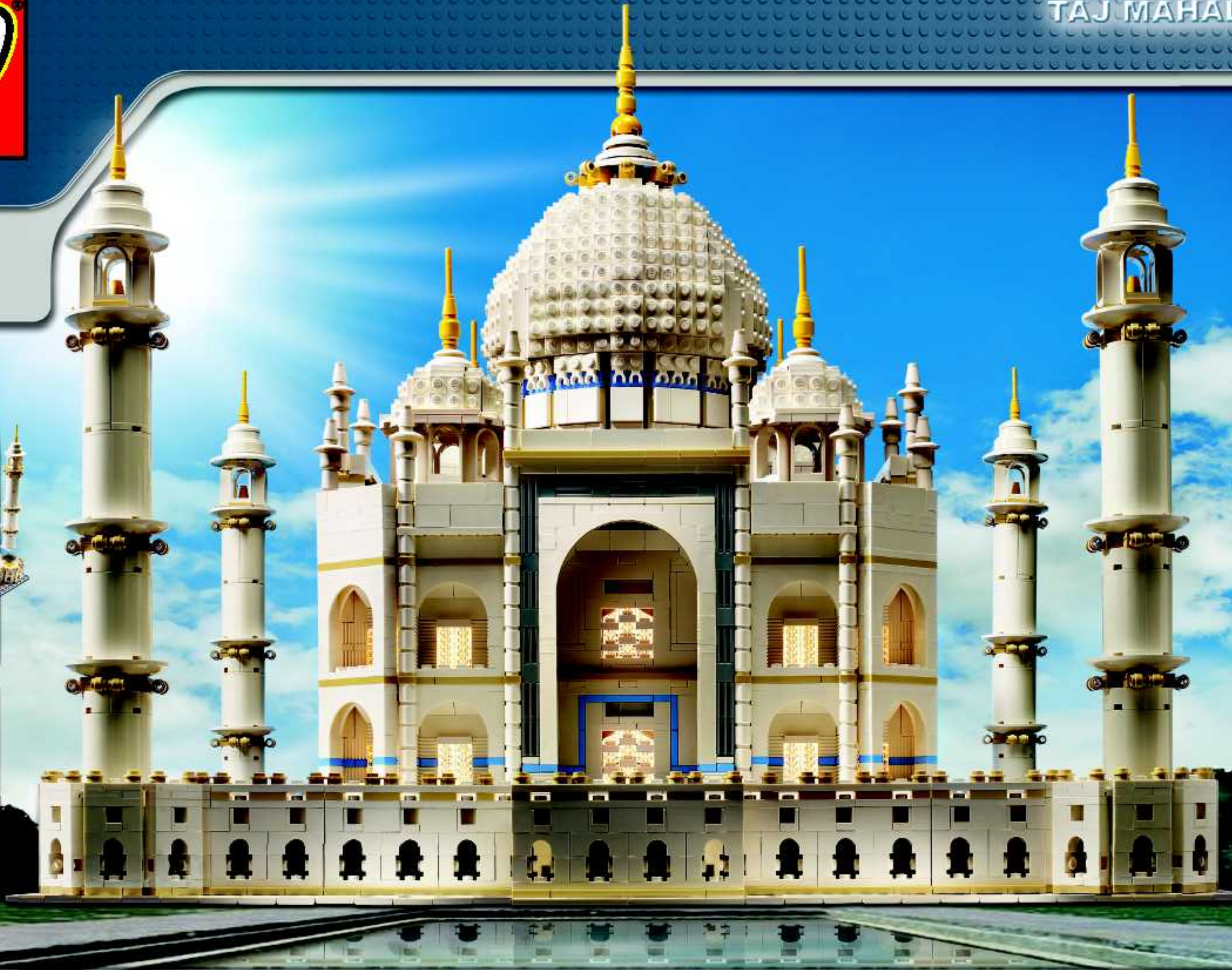

TAJ MAHAL

10189

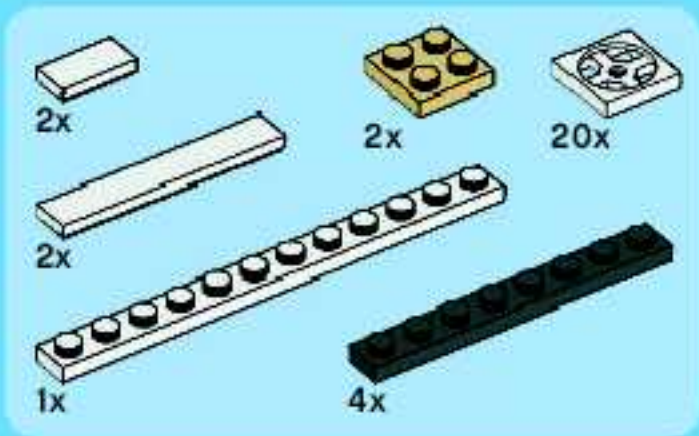

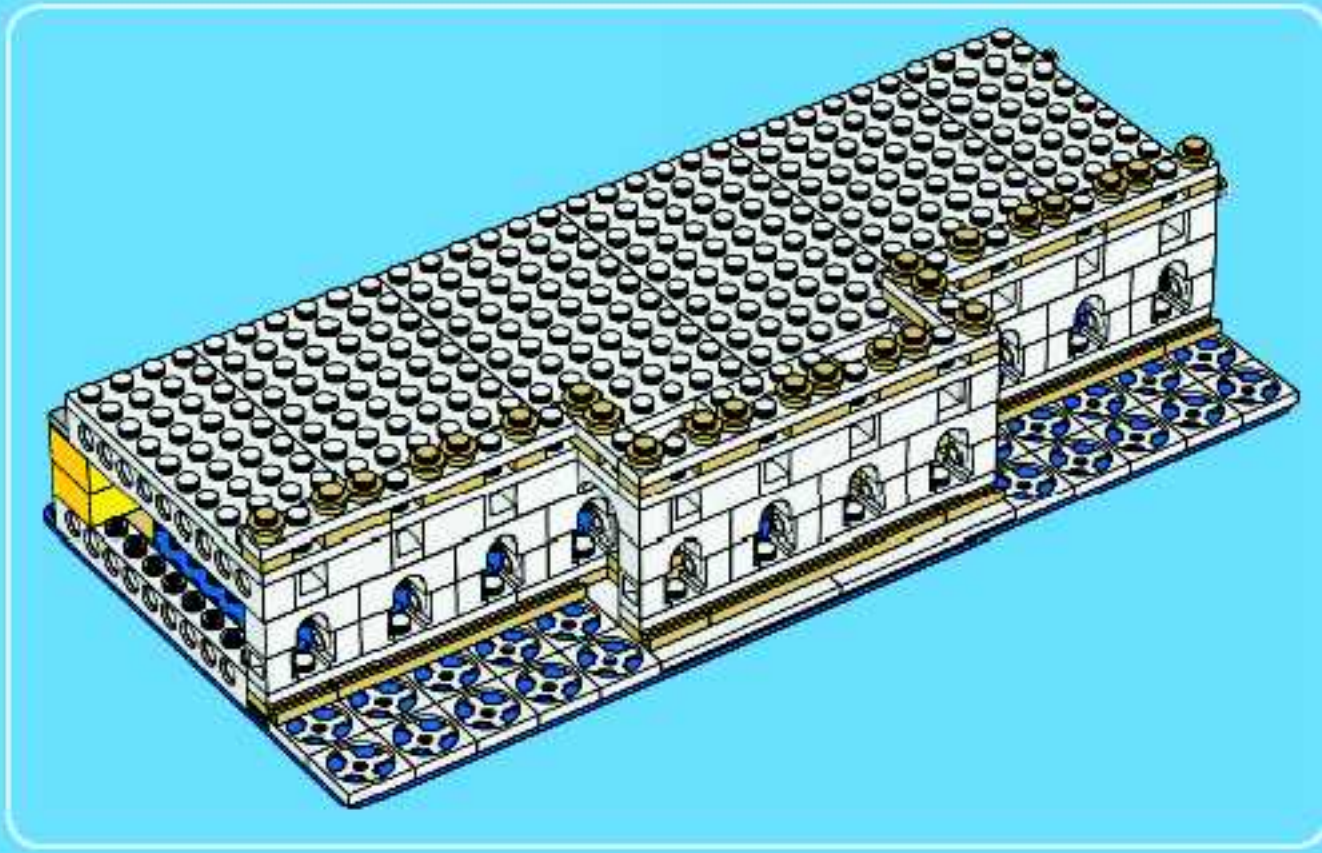

1

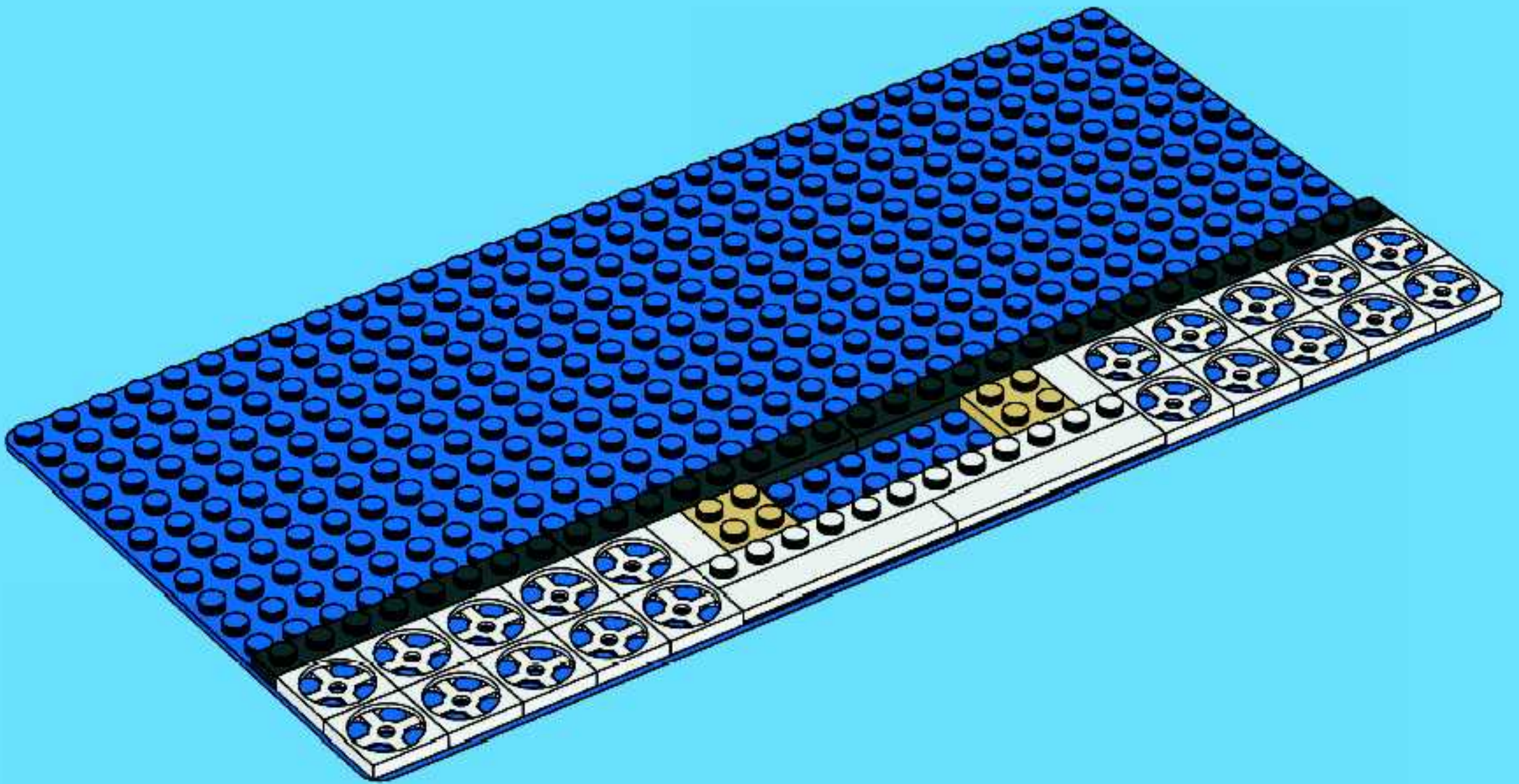

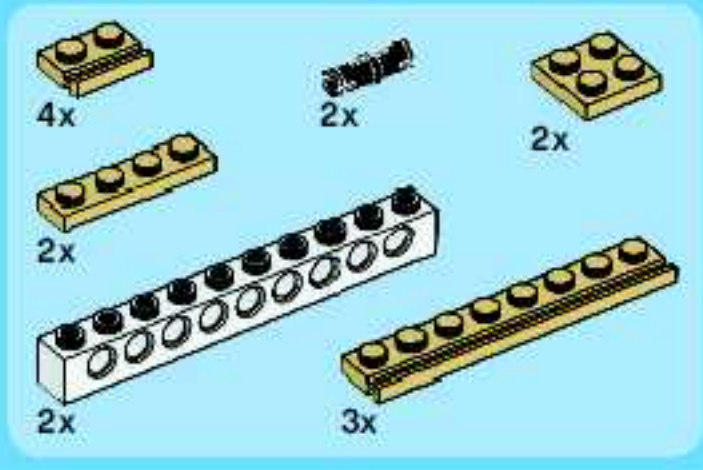

2

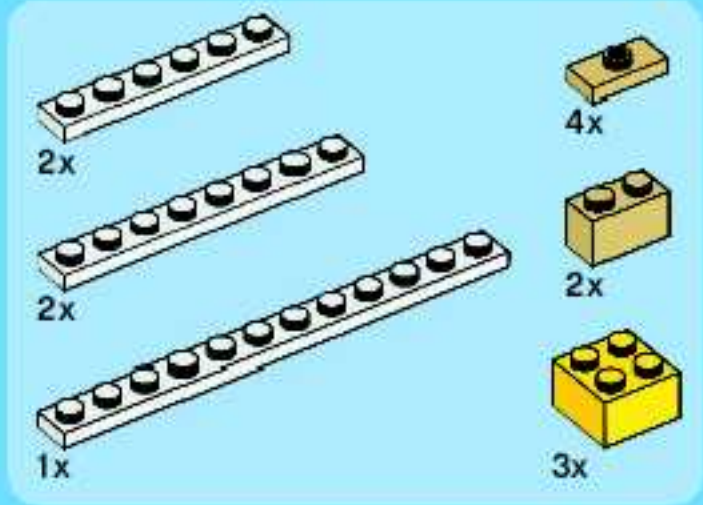
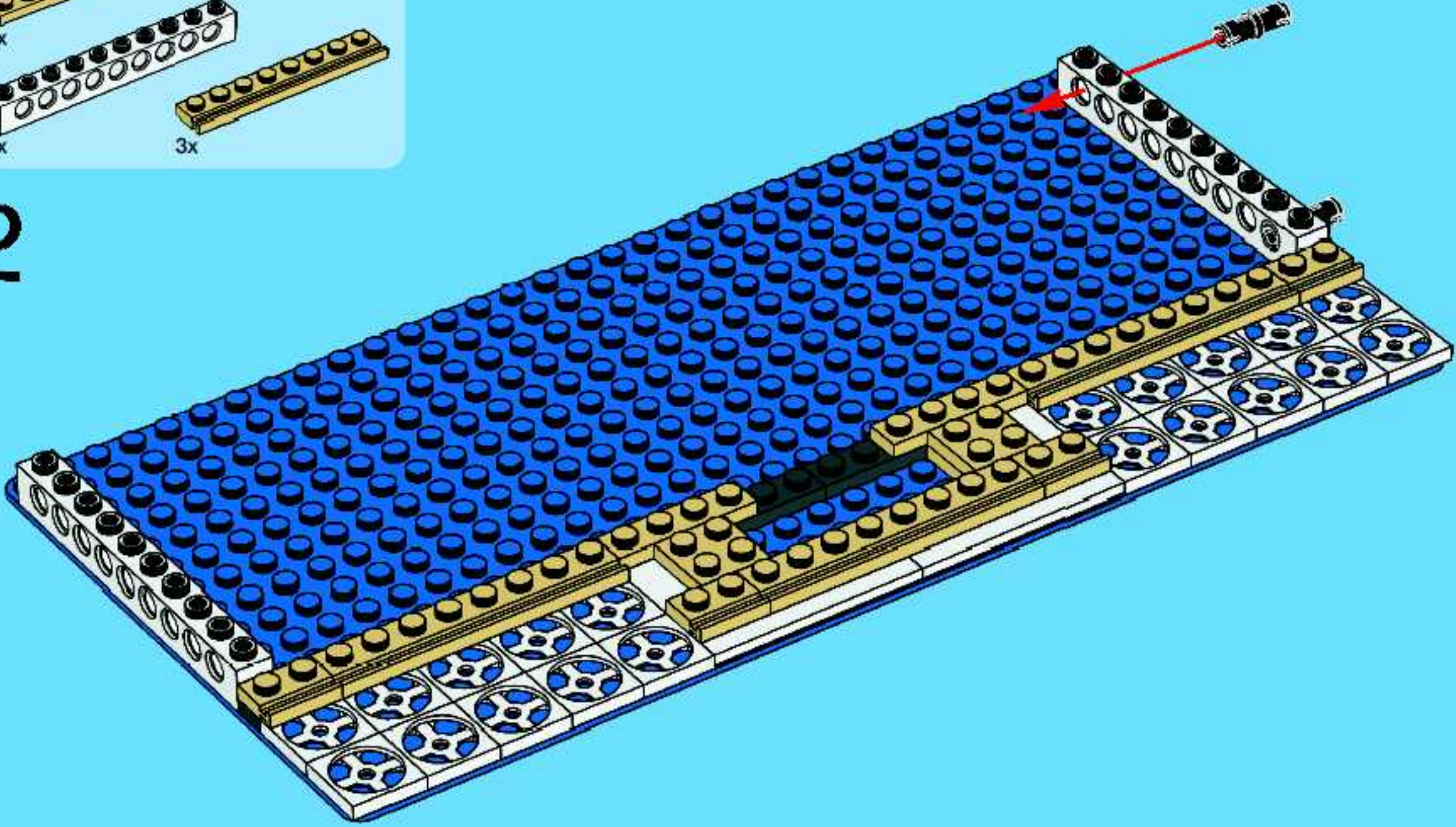

3

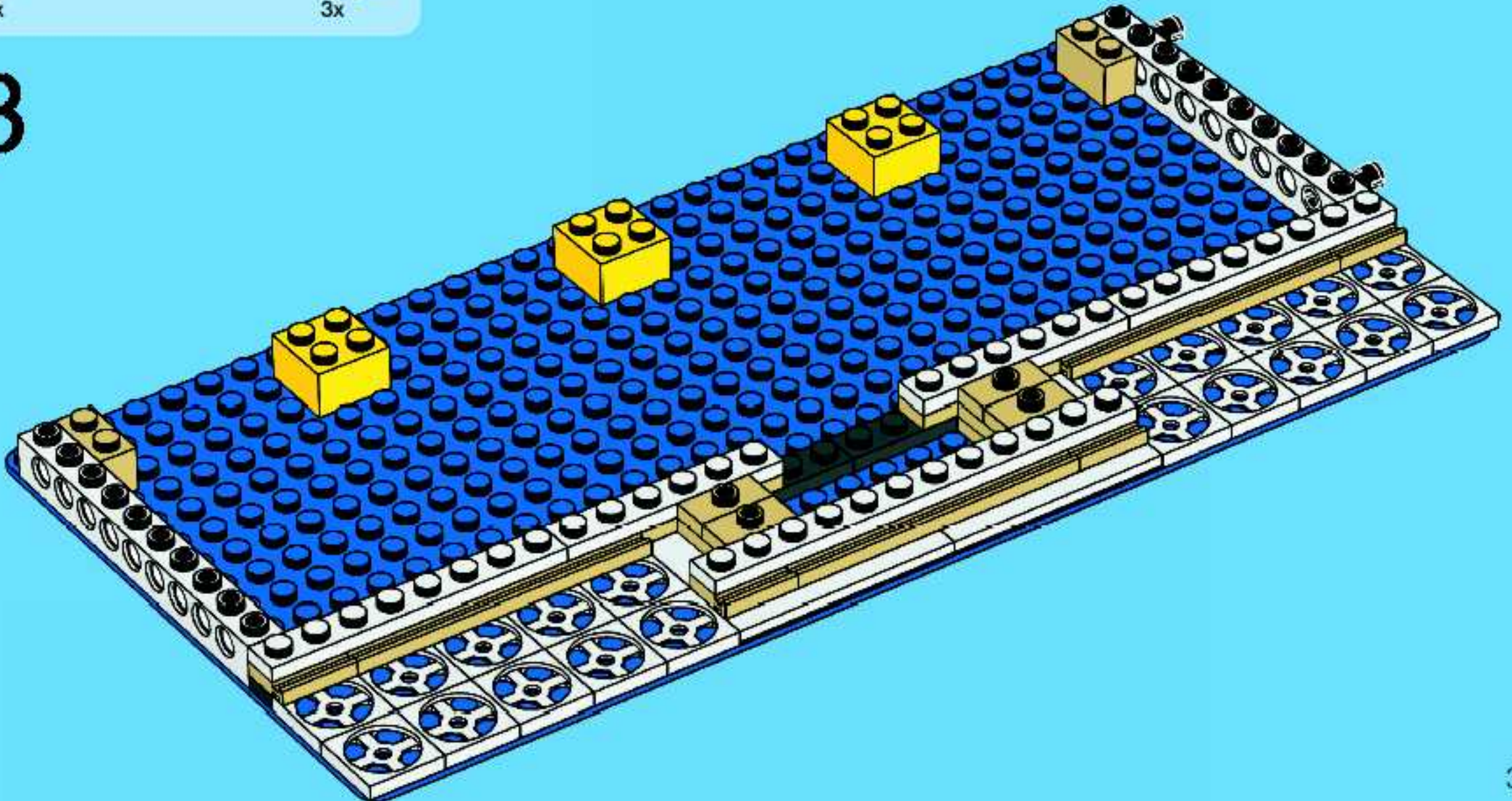

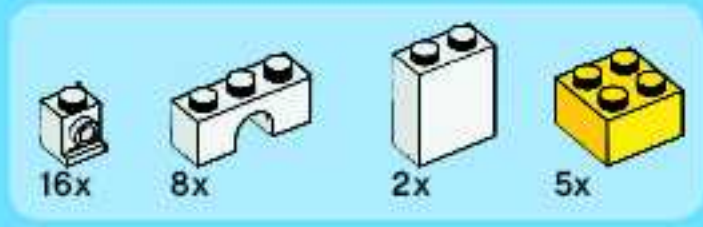

4

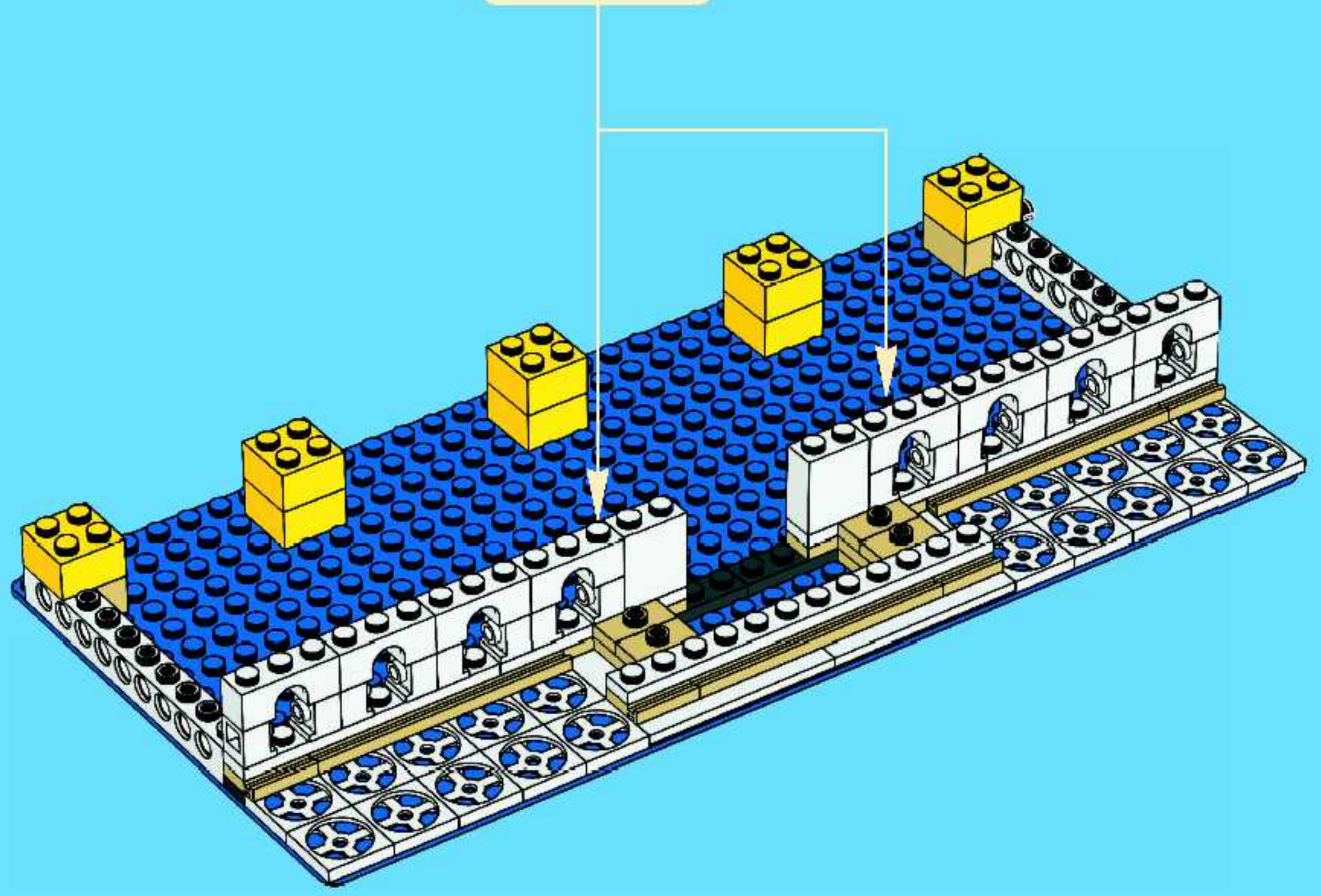
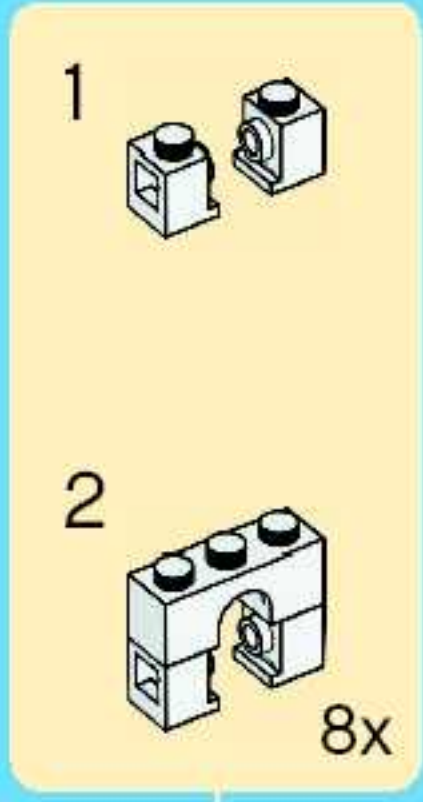



12x



6x



6x



2x

# 5

1



2



3x

3

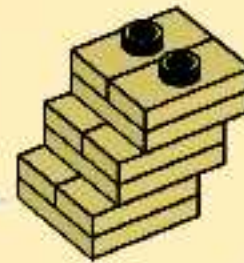

2x

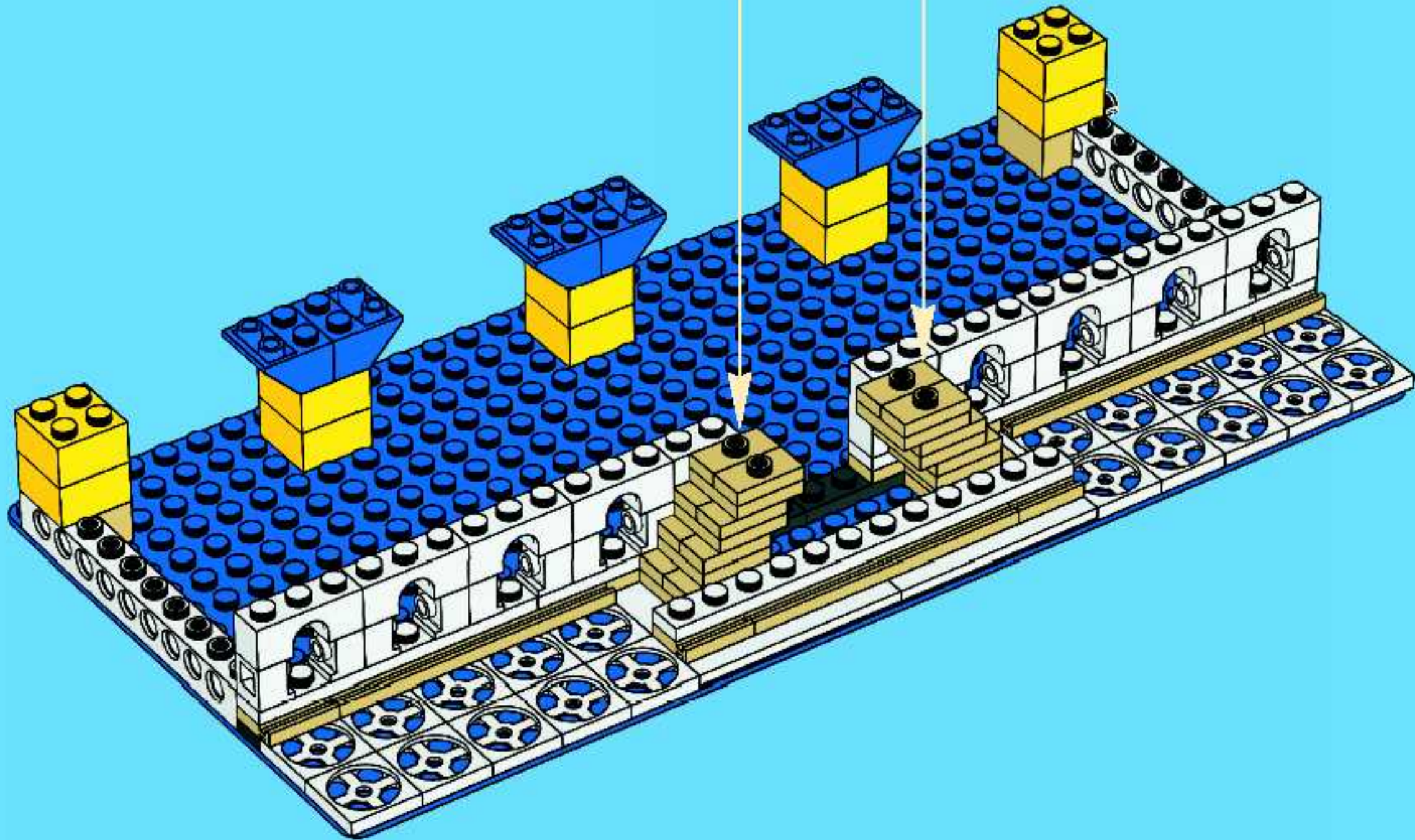

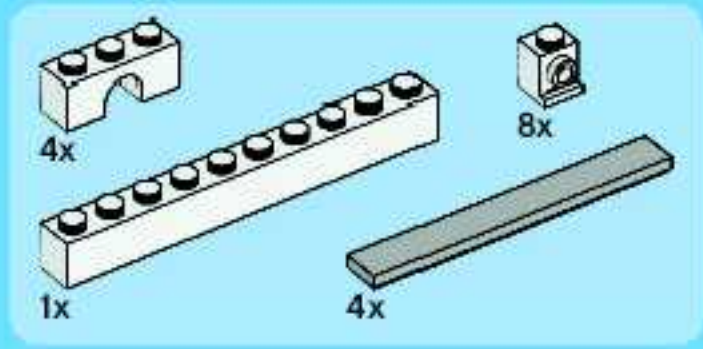

6

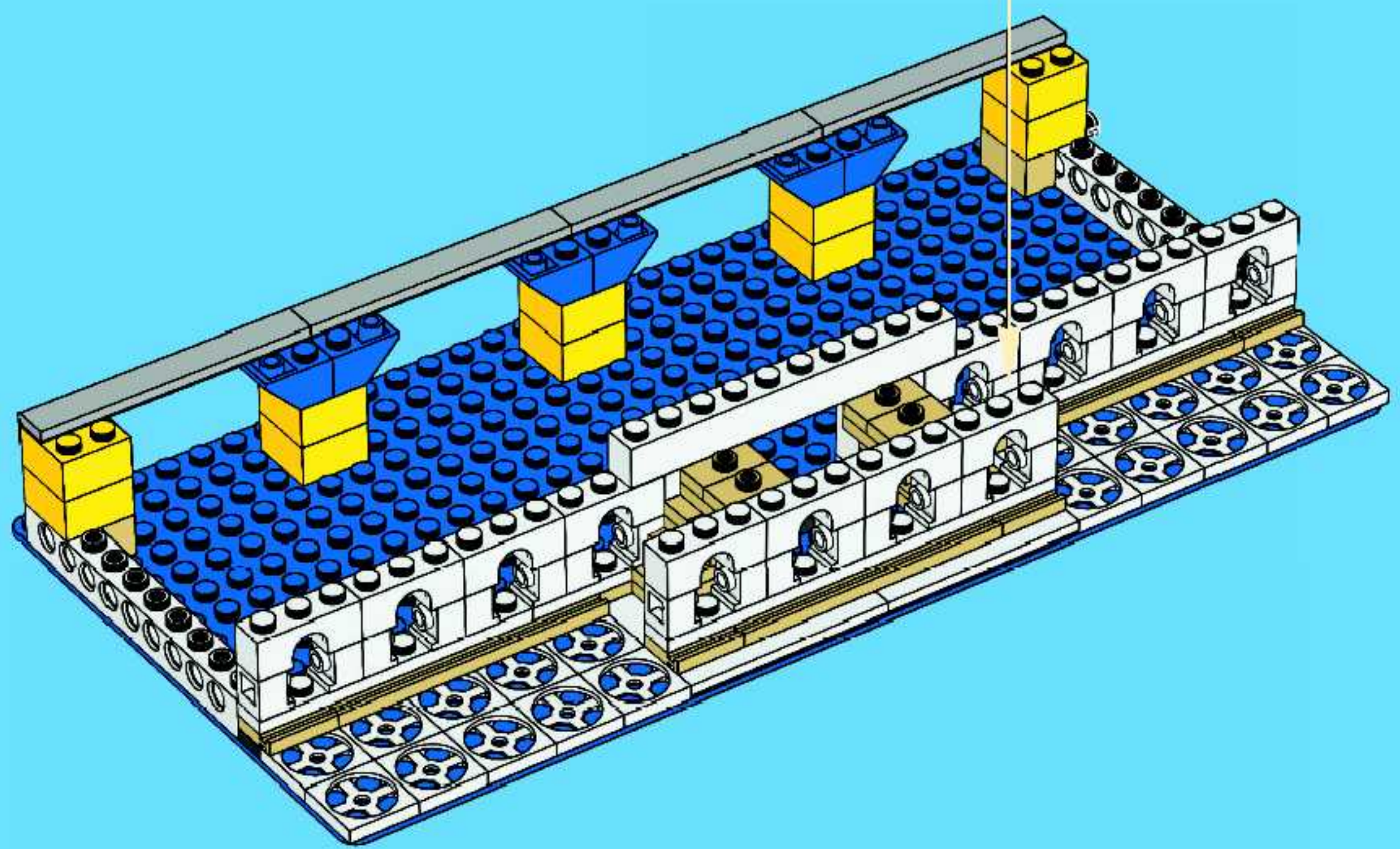
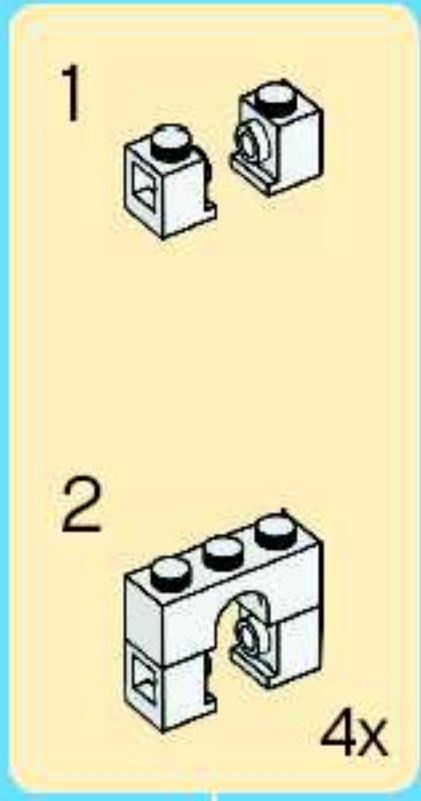





10x



9x

8

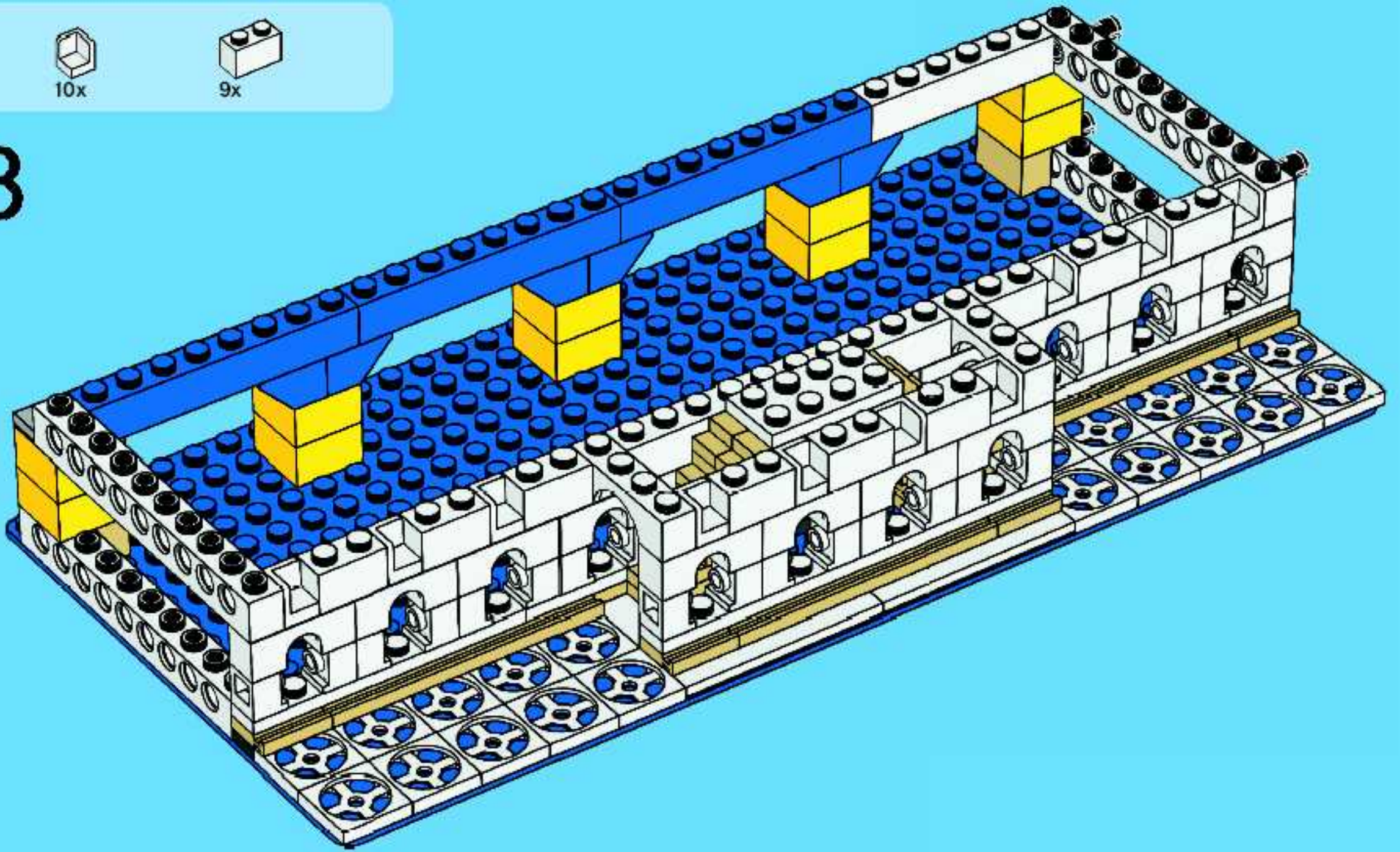

2x



1x



2x



4x

9

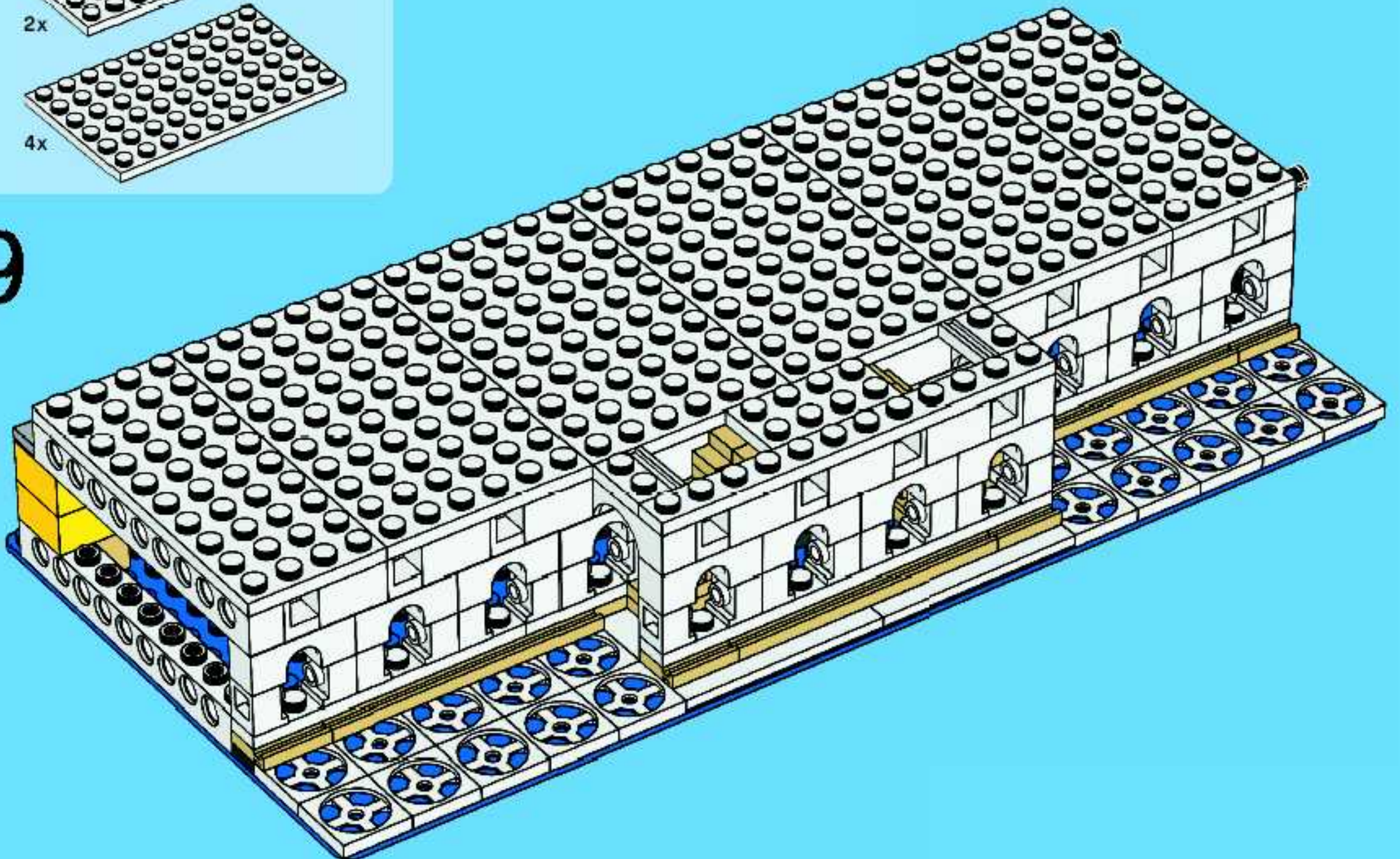





6x



9x

# 10

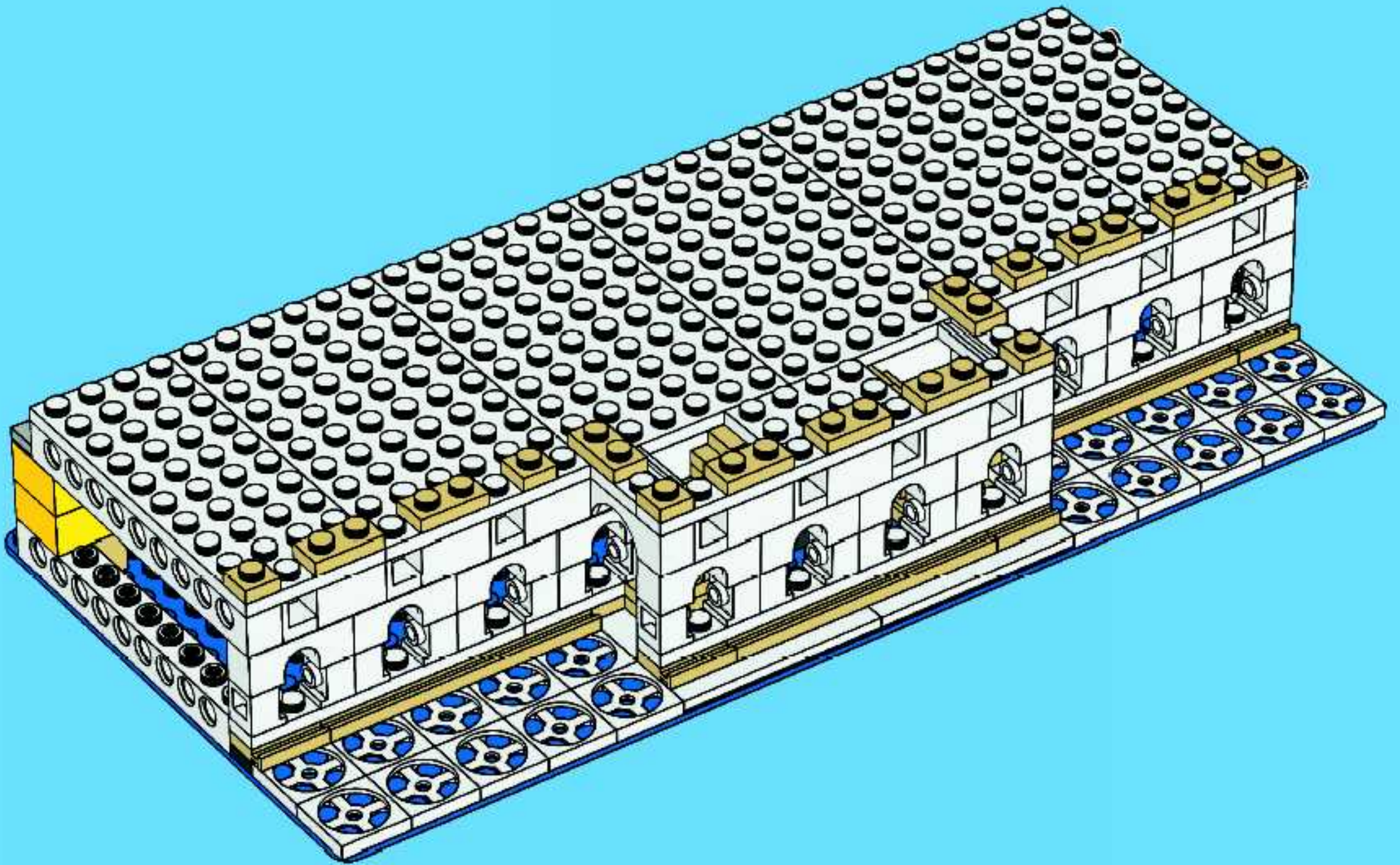

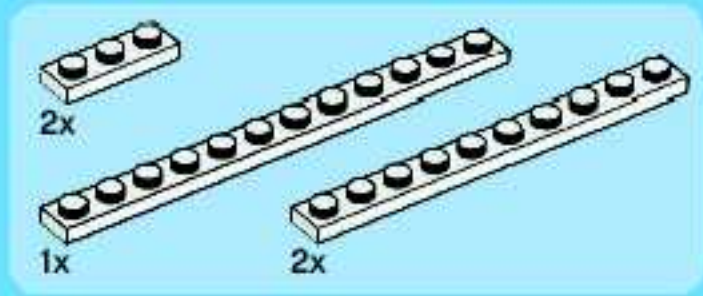

11

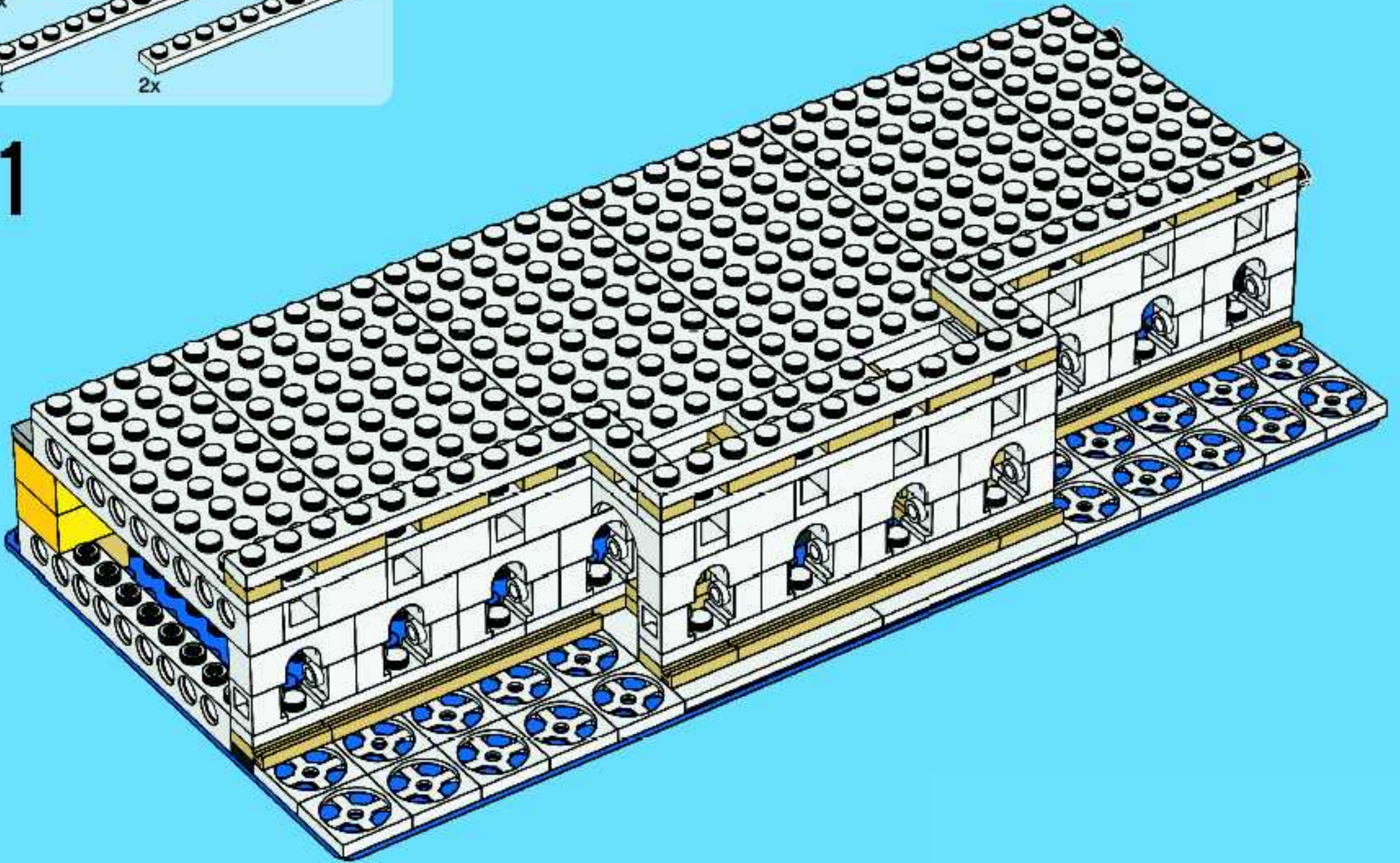

12

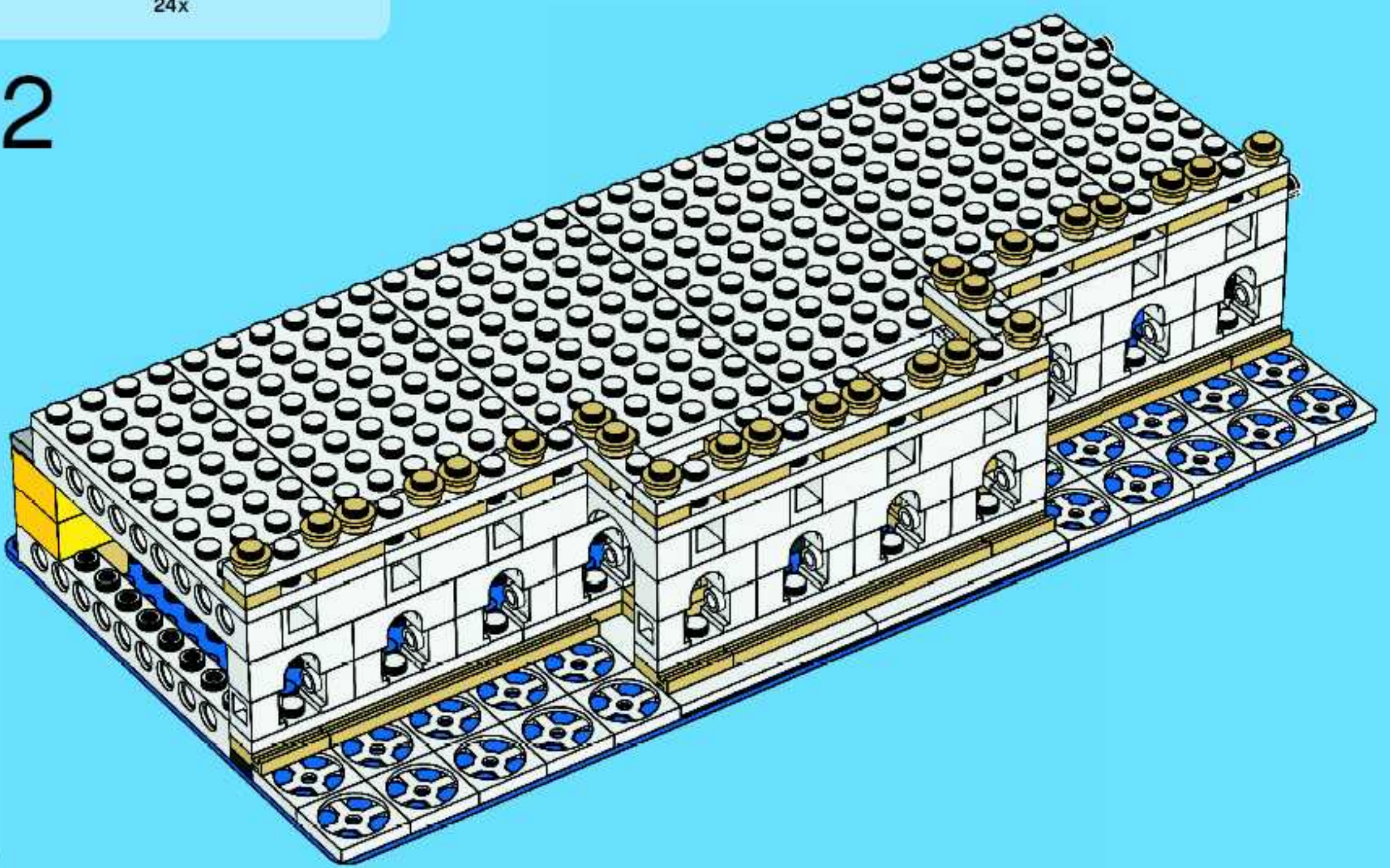

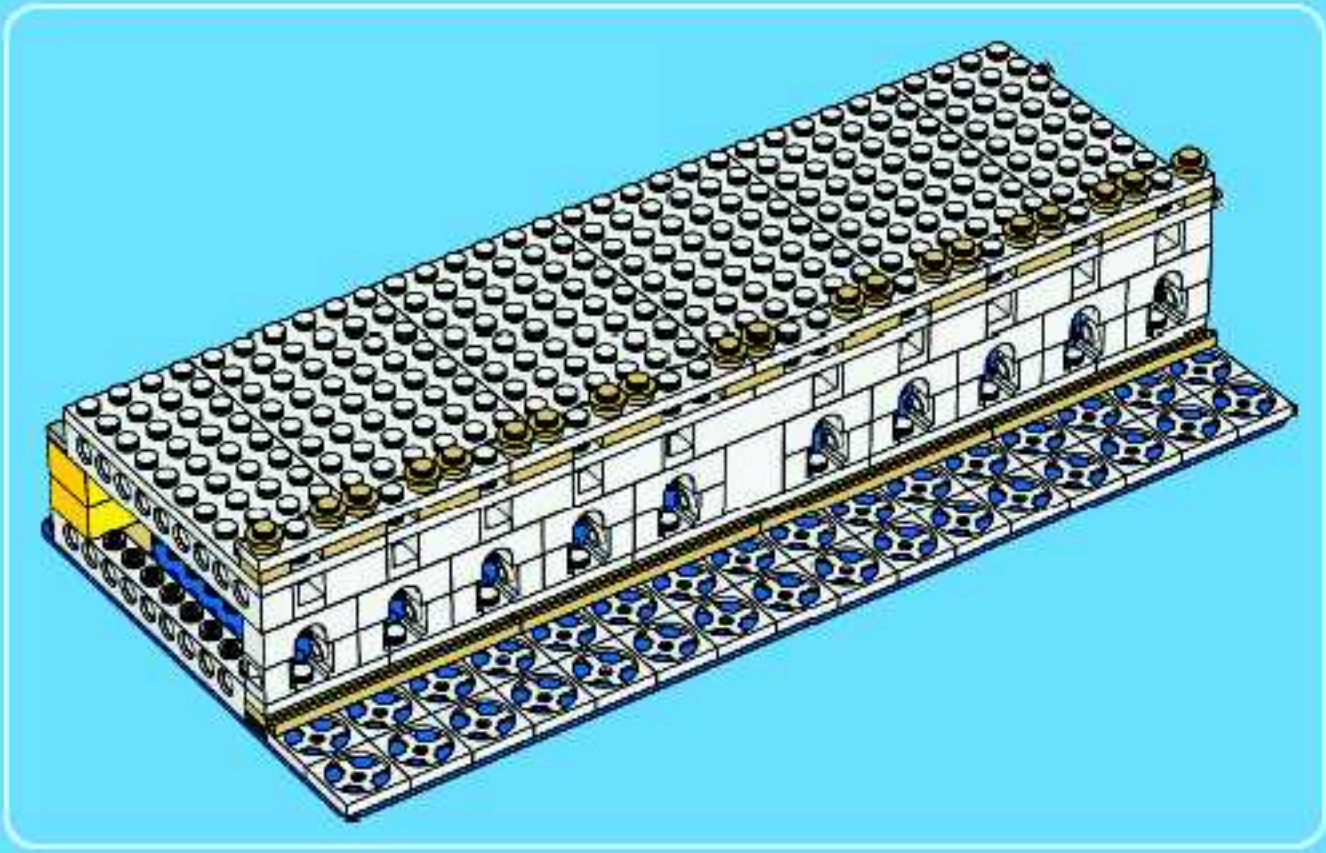

1

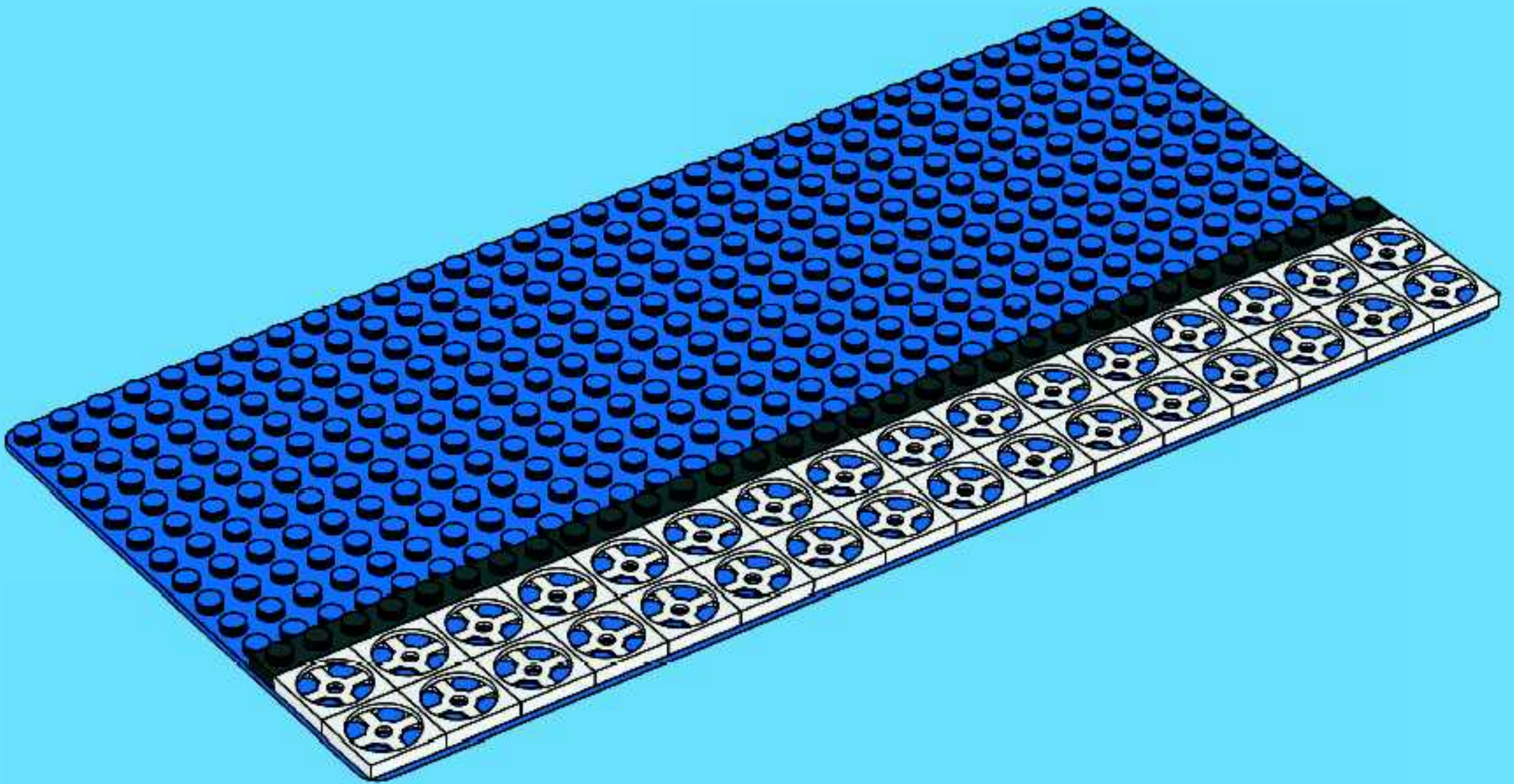

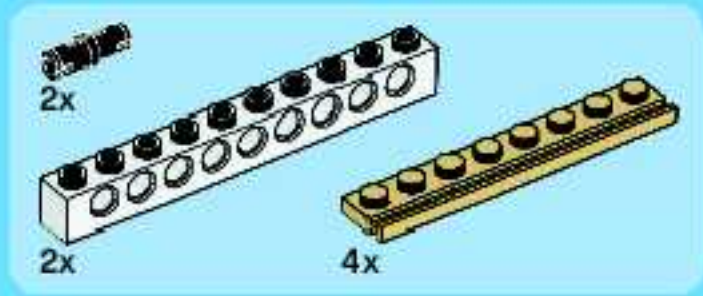

2

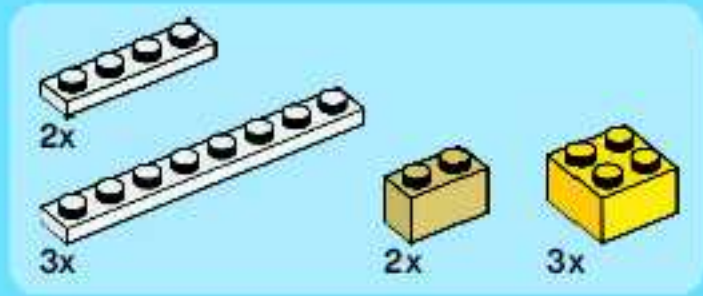
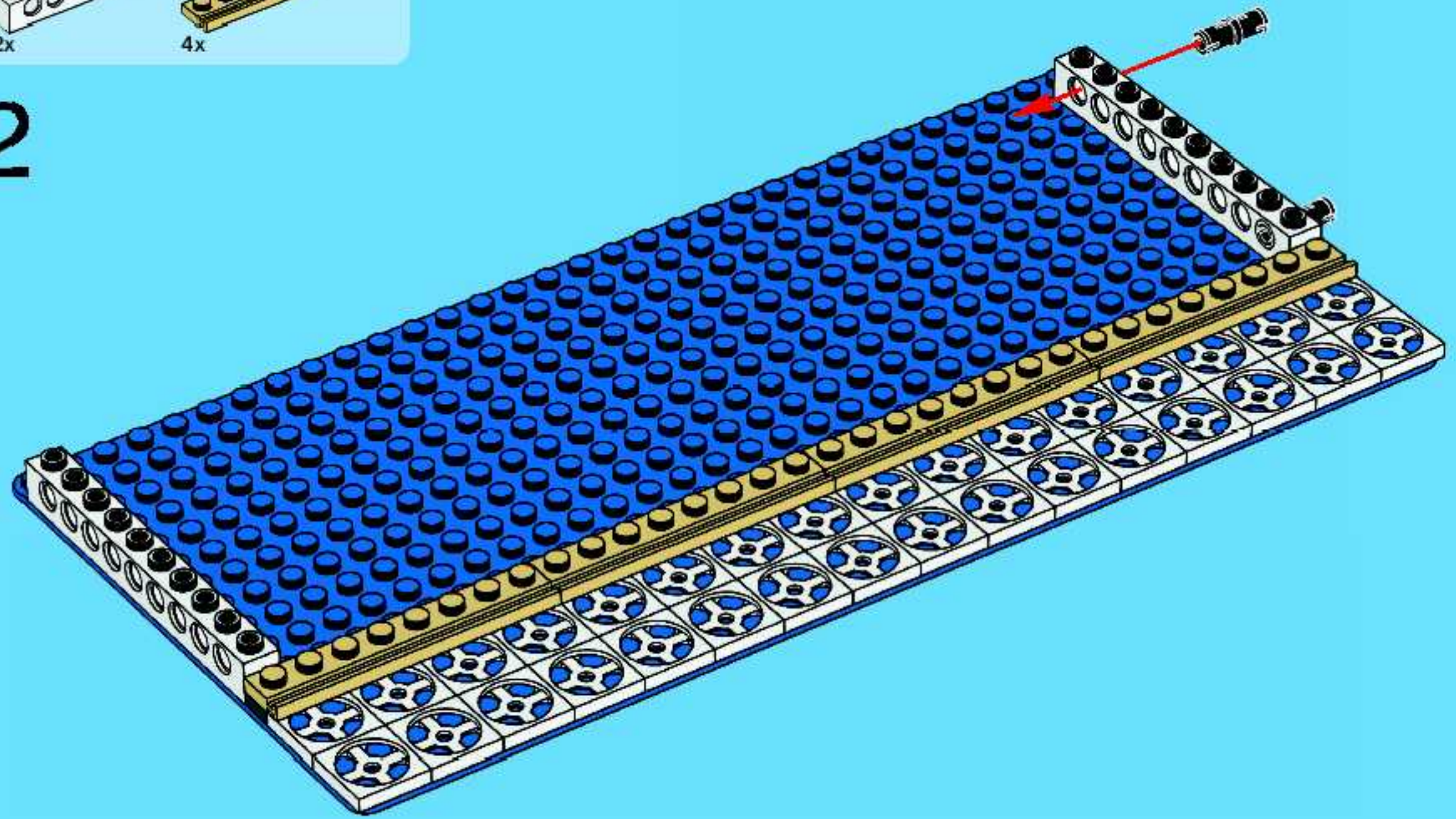

3

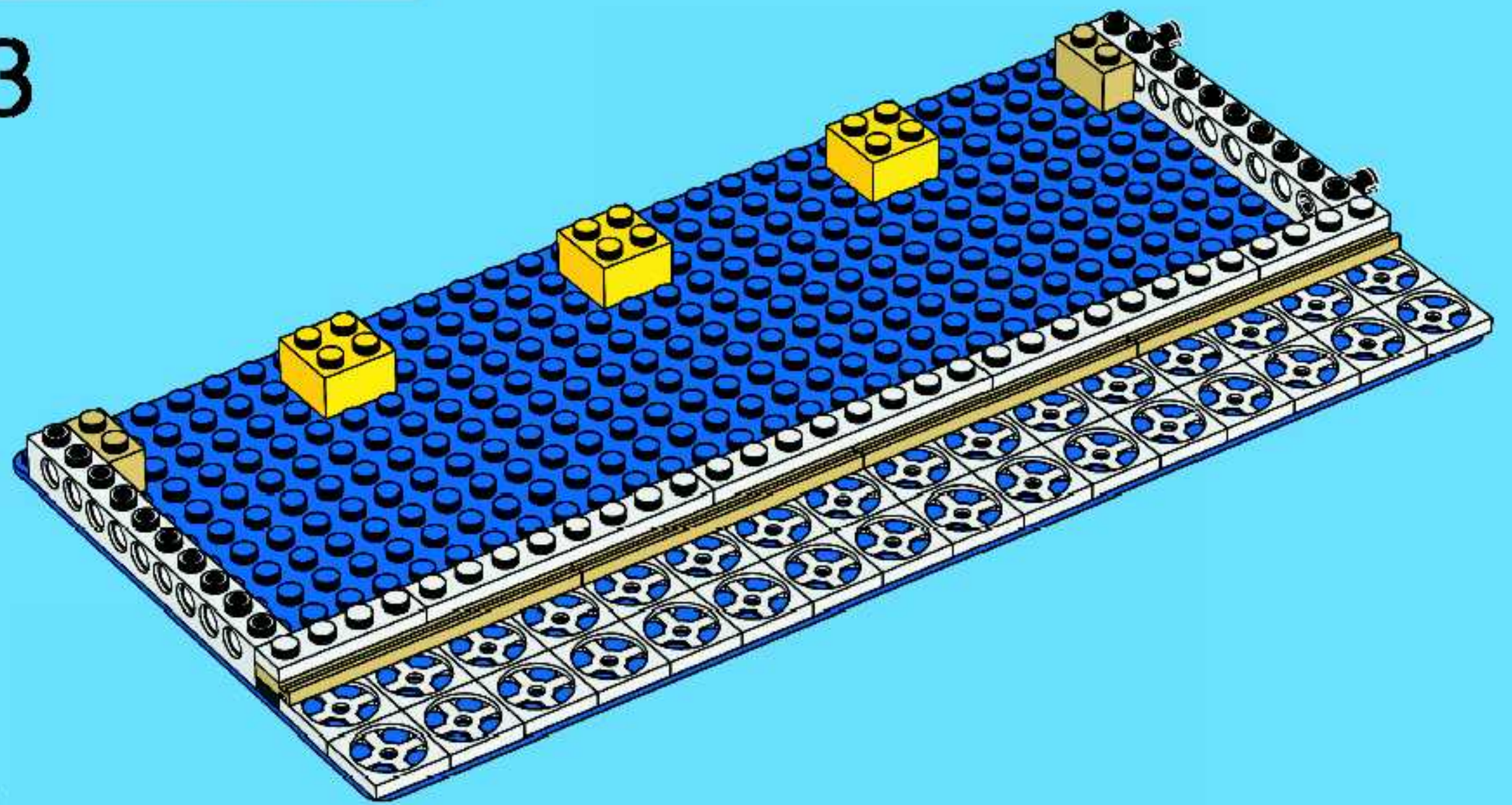

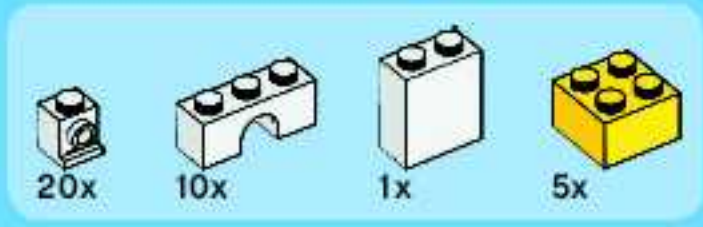

4

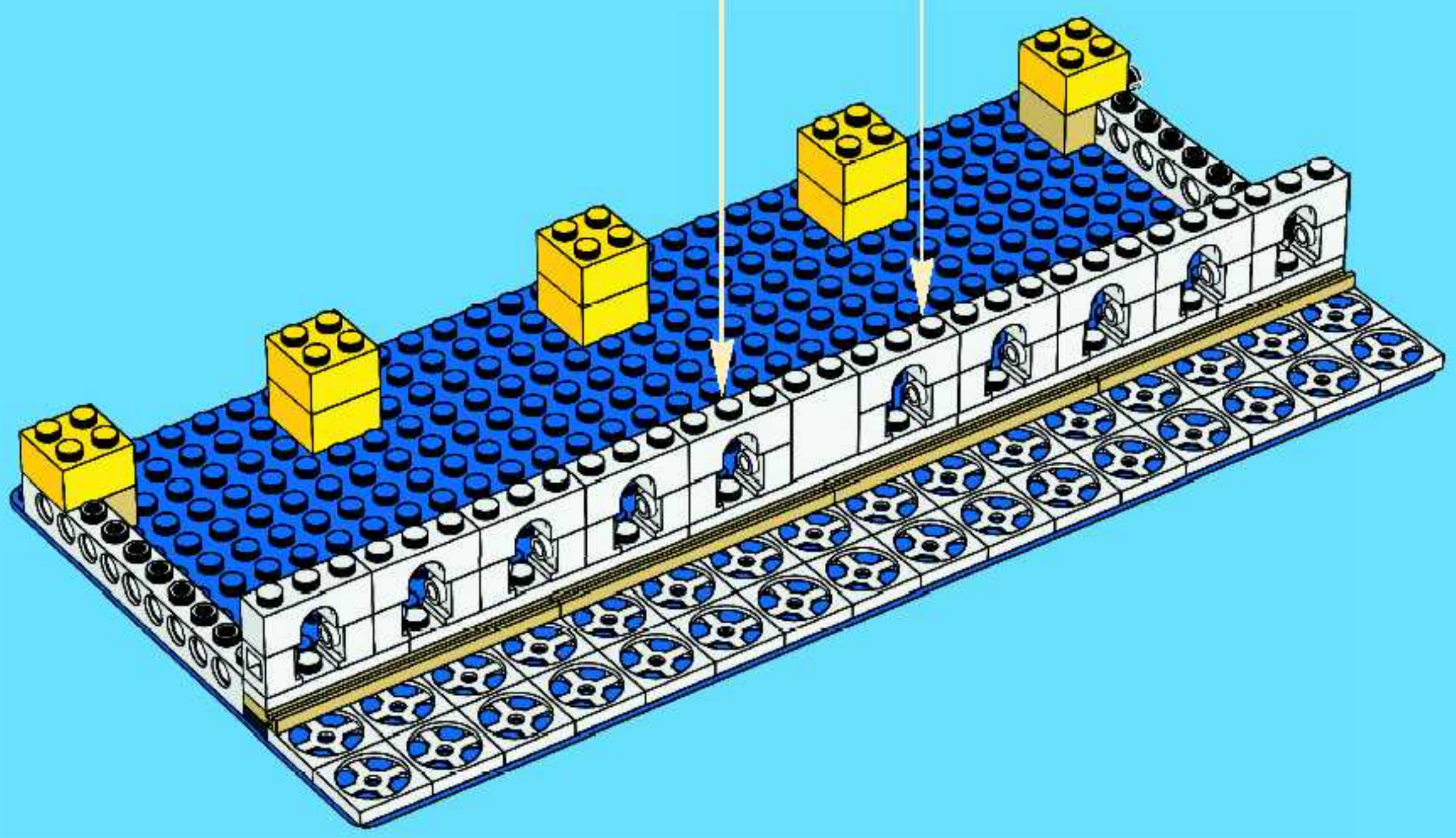
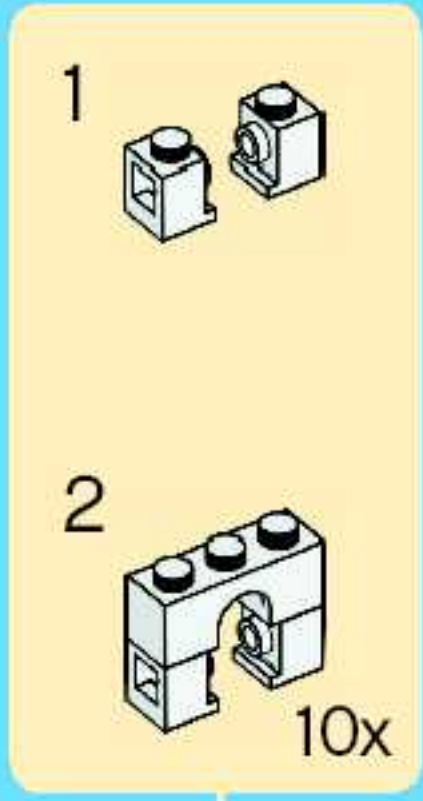



2x



6x

# 5

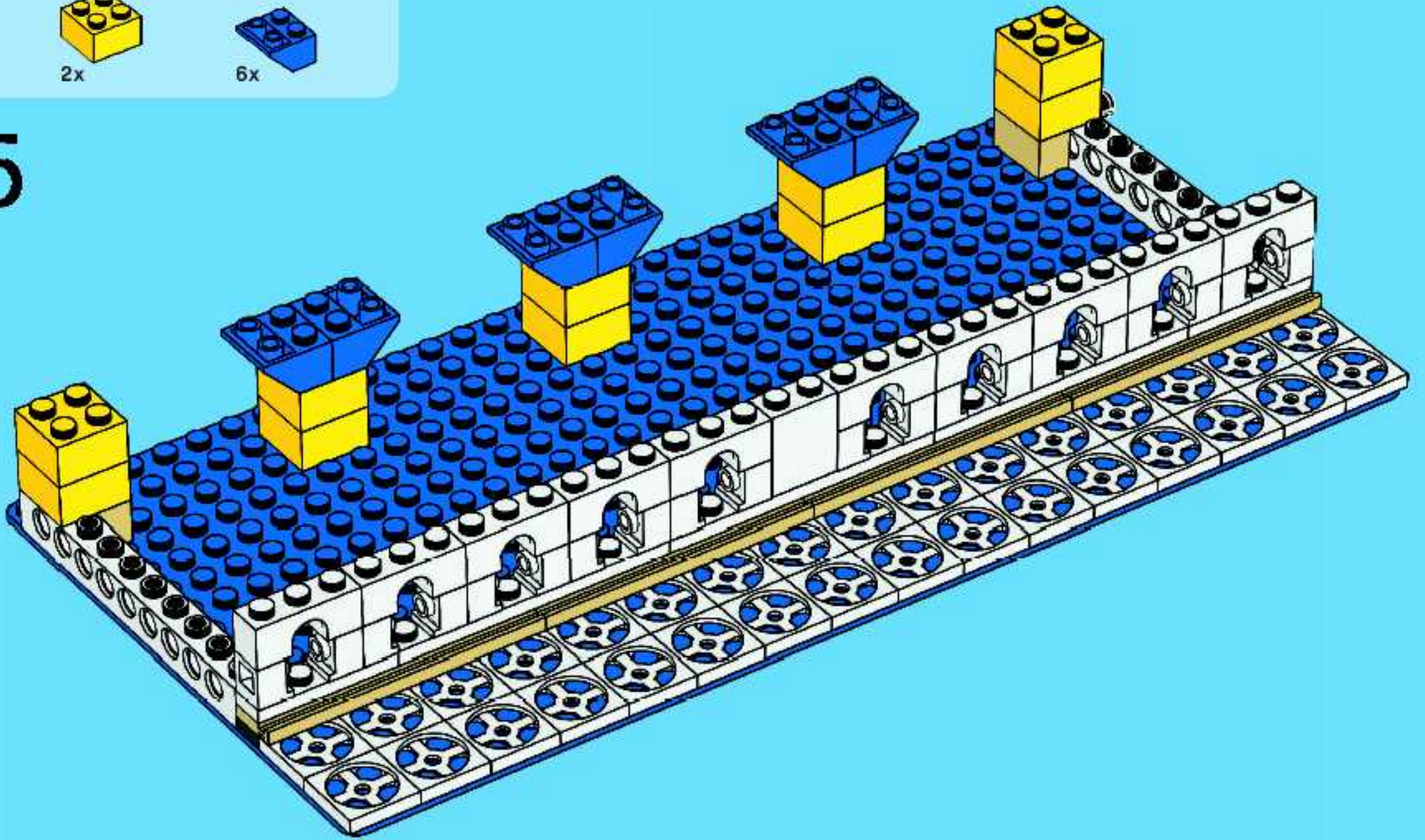

2x



2x

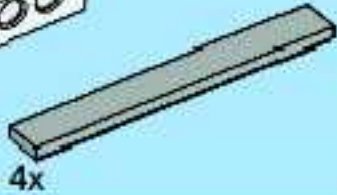

4x

# 6

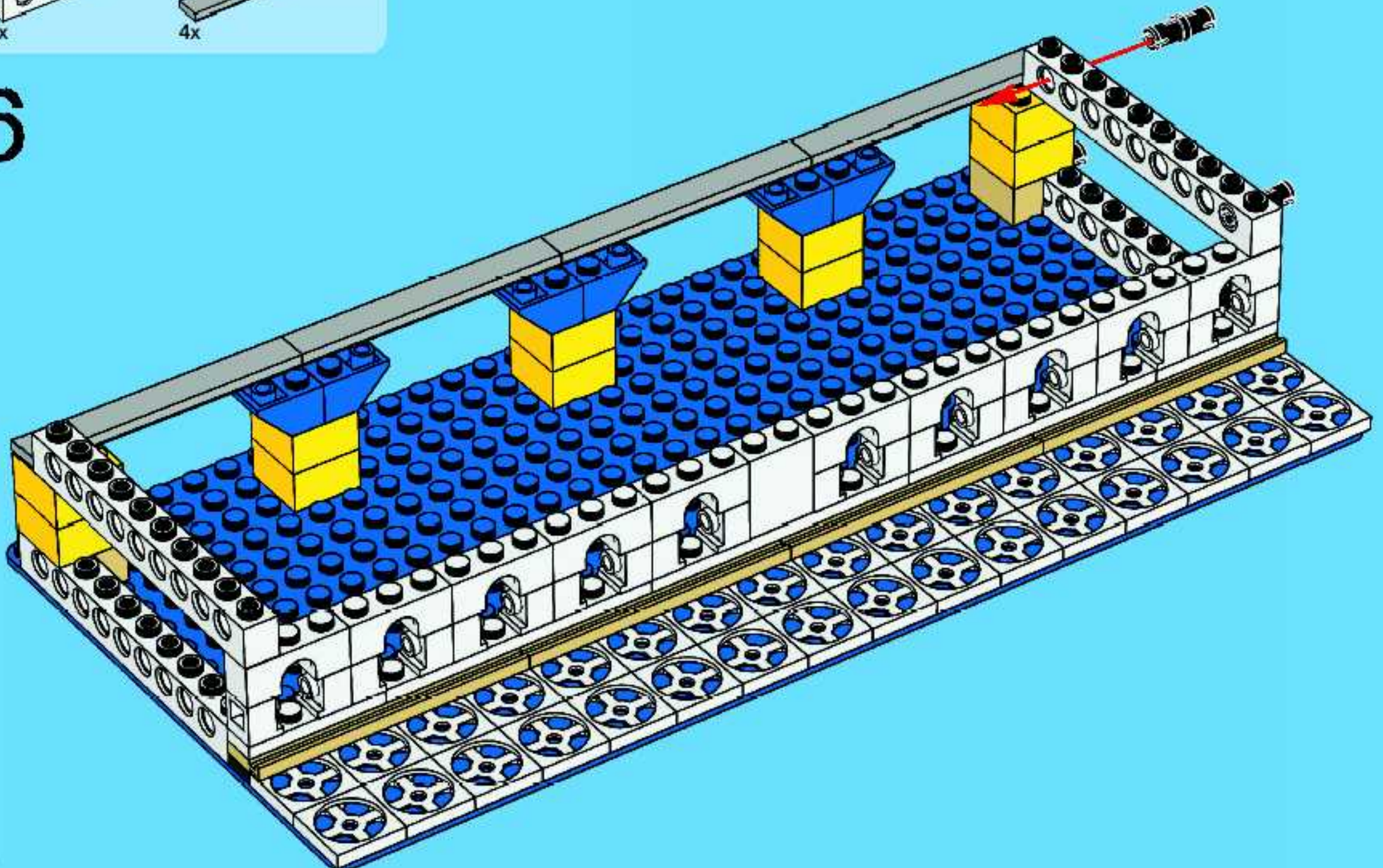

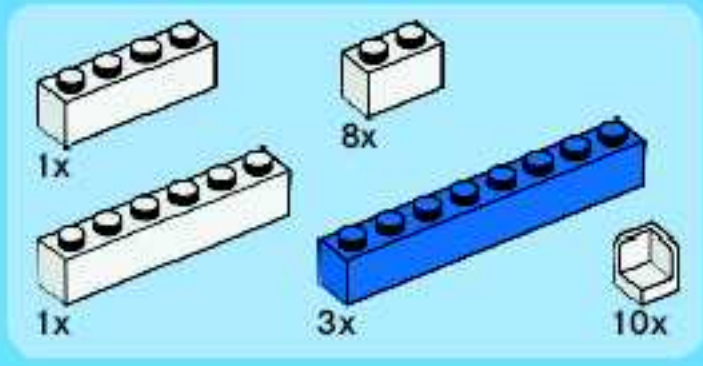

7

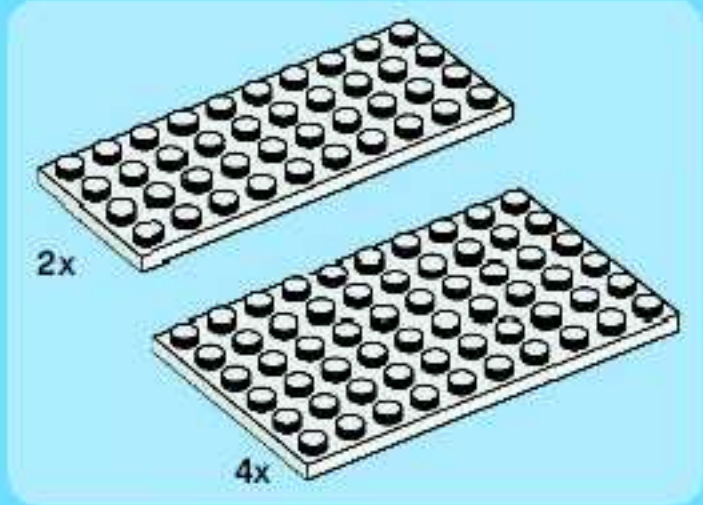
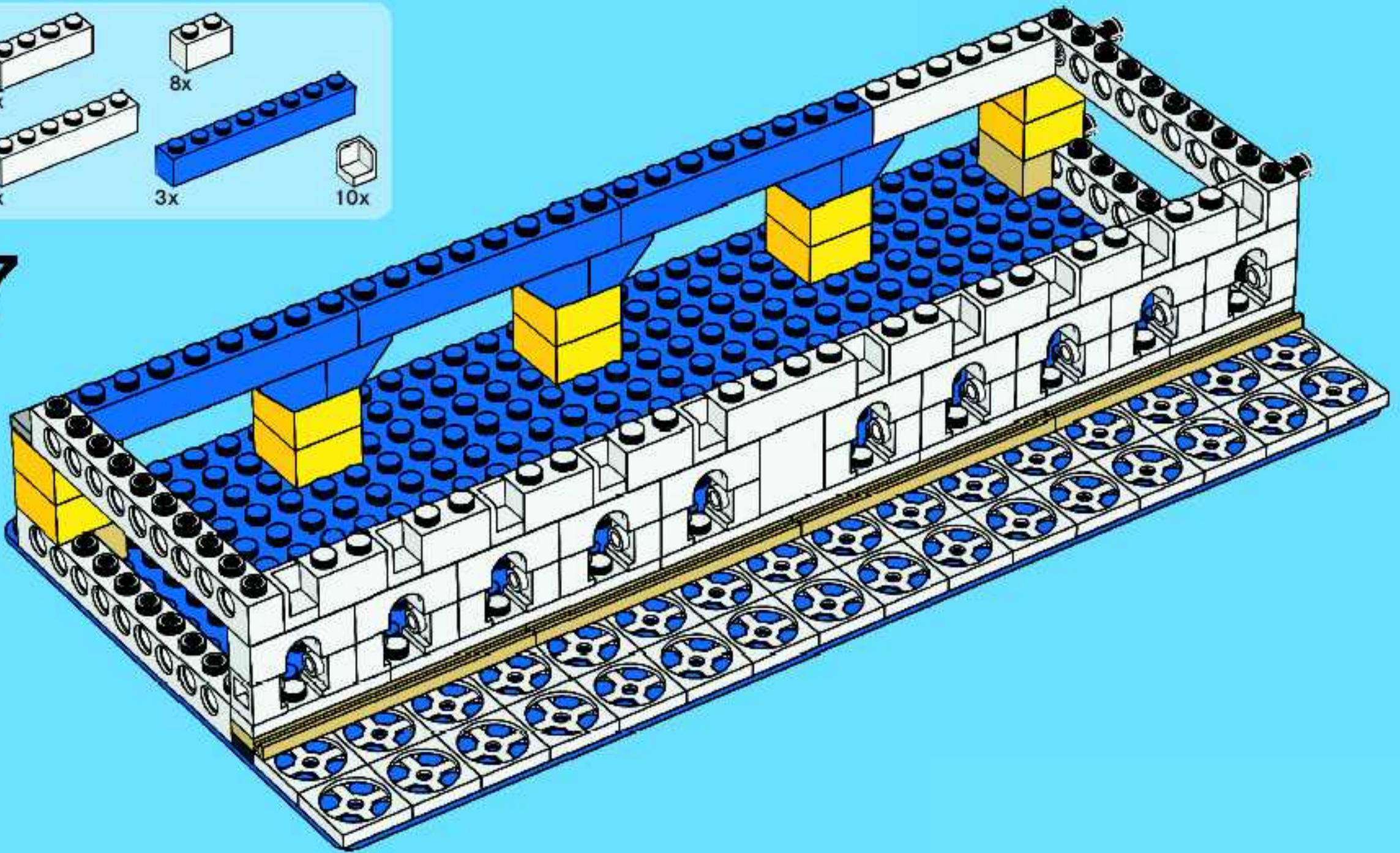

8

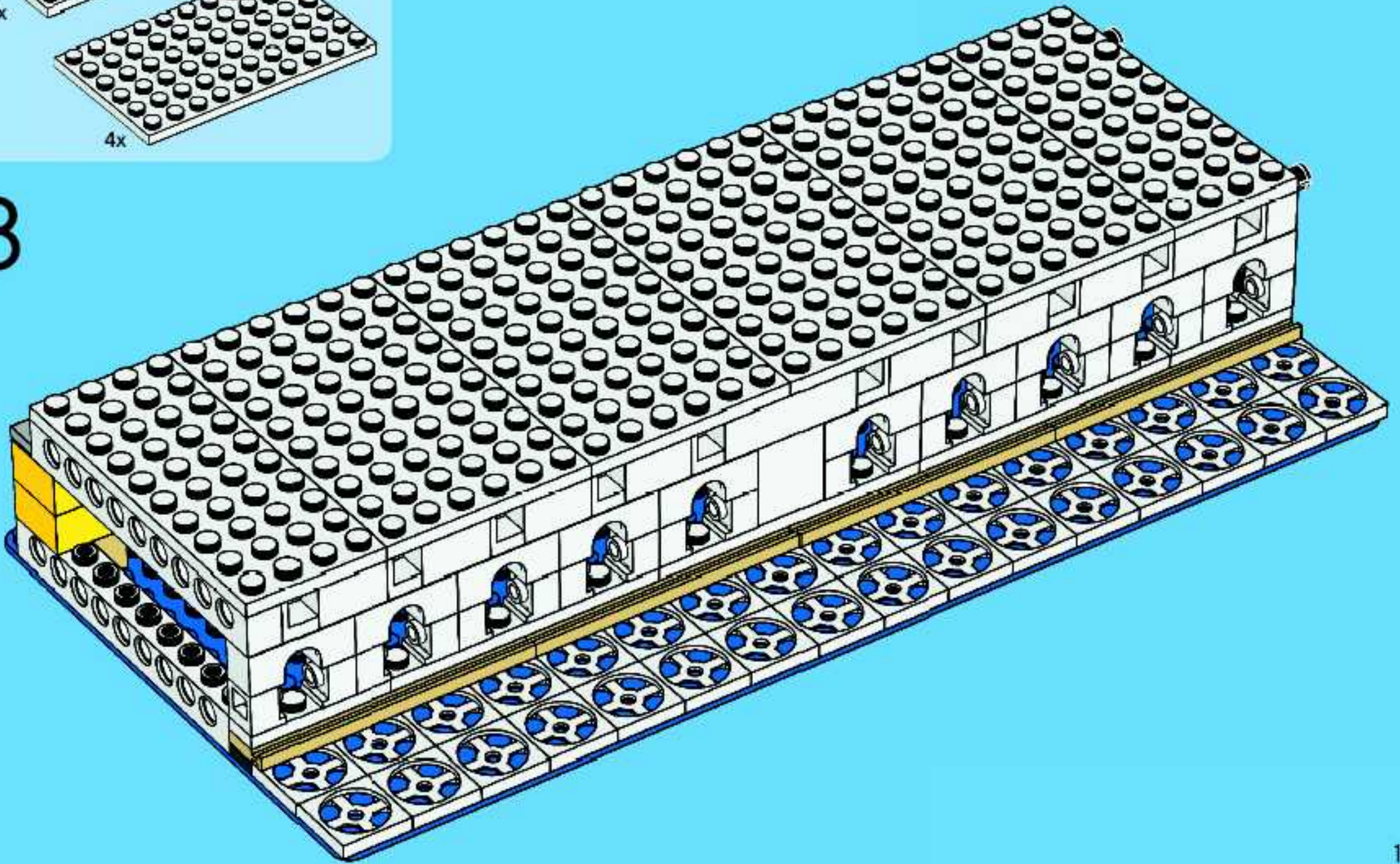



2x



9x

# 9

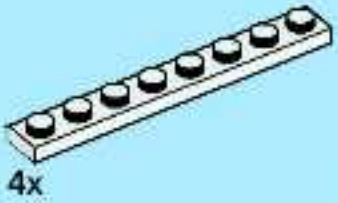
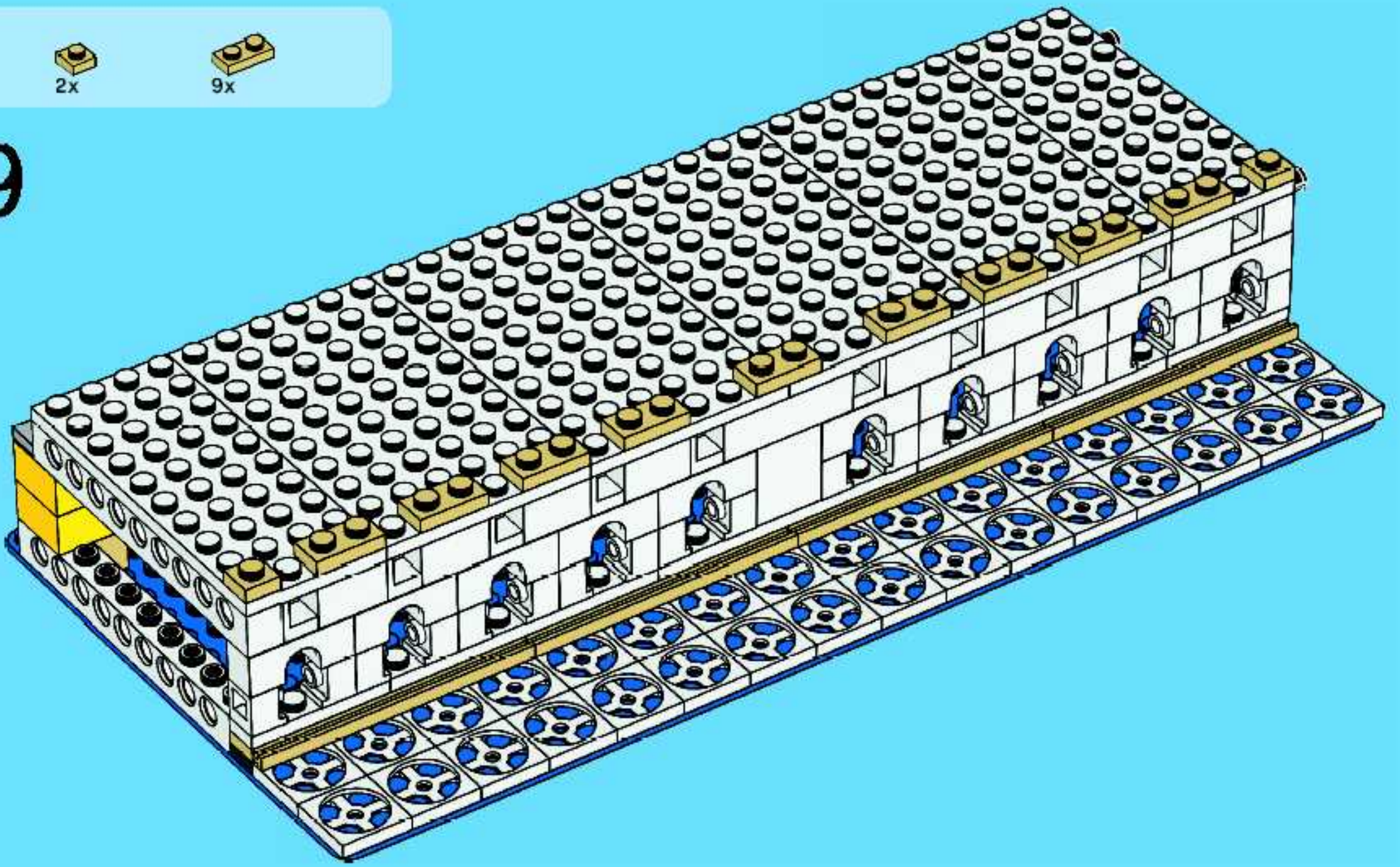

4x

# 10

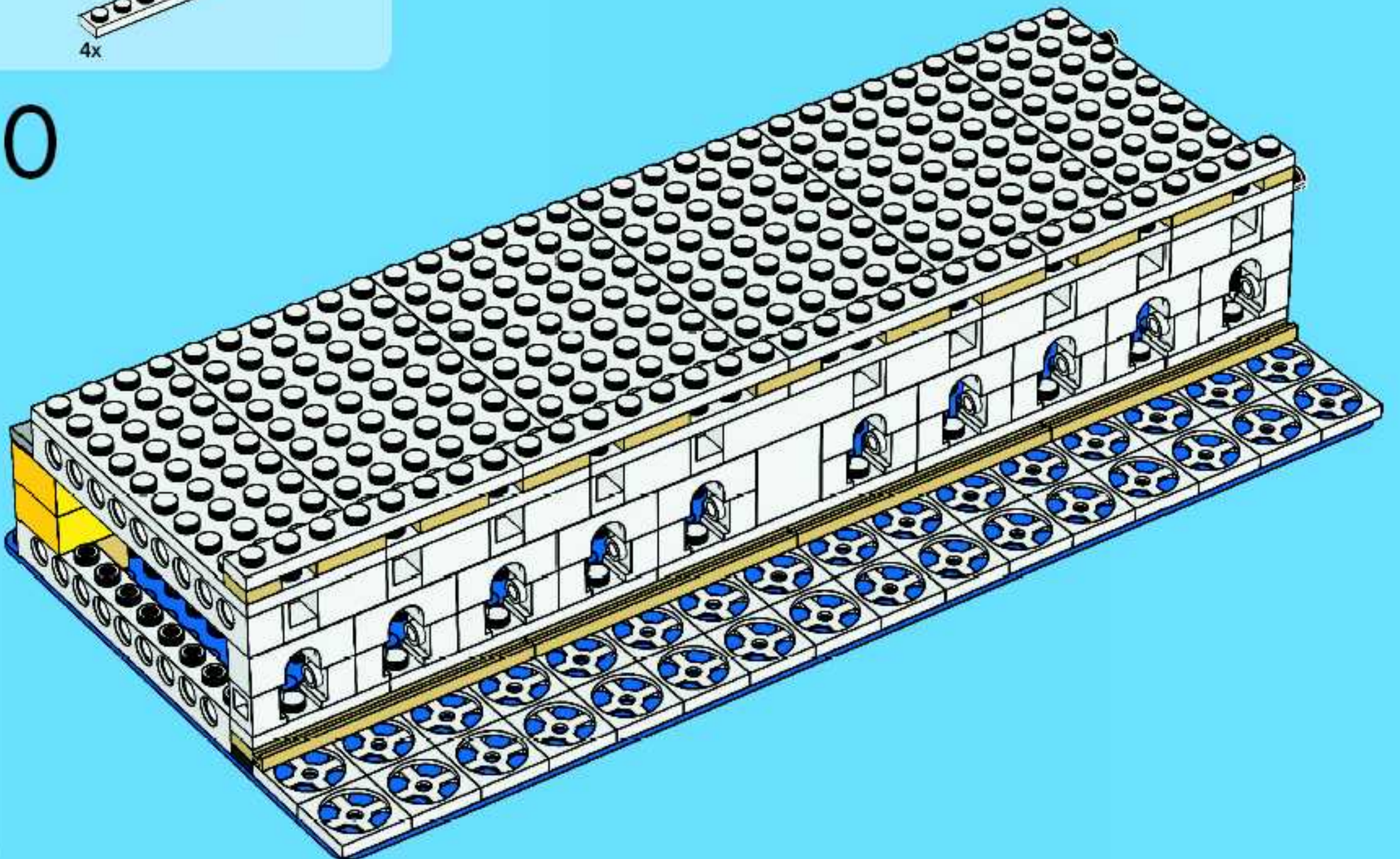



  
20x

11

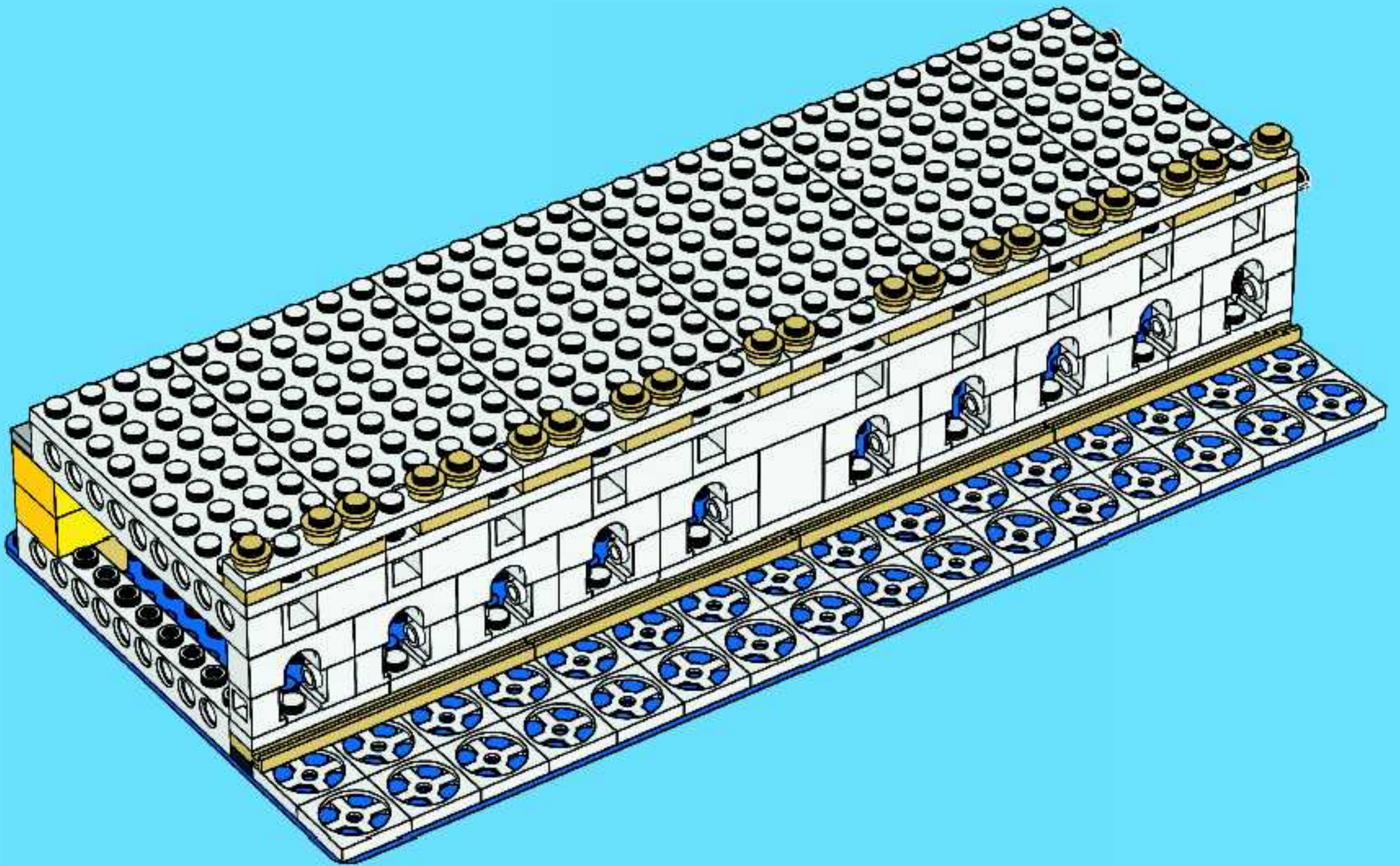

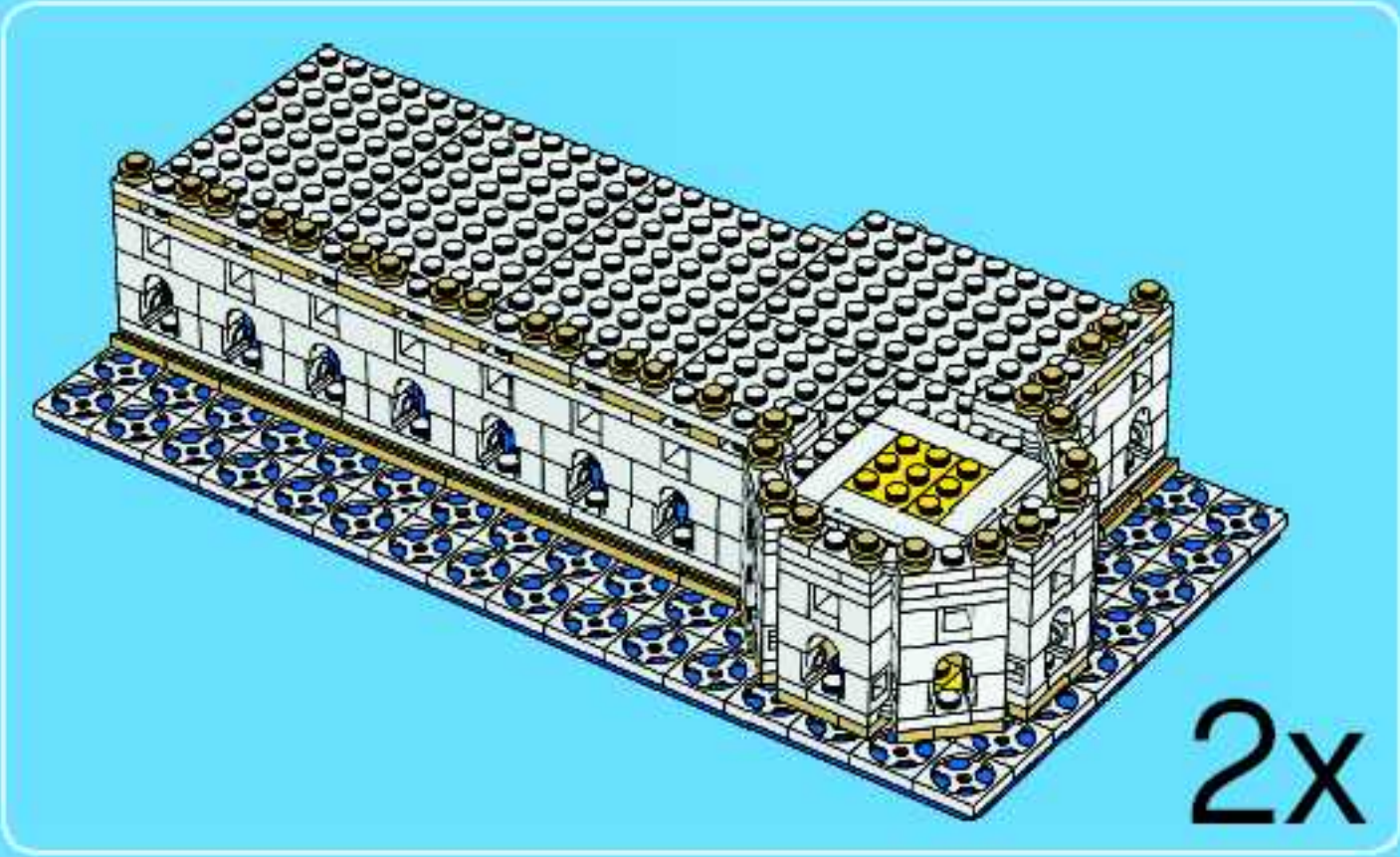

39x

1

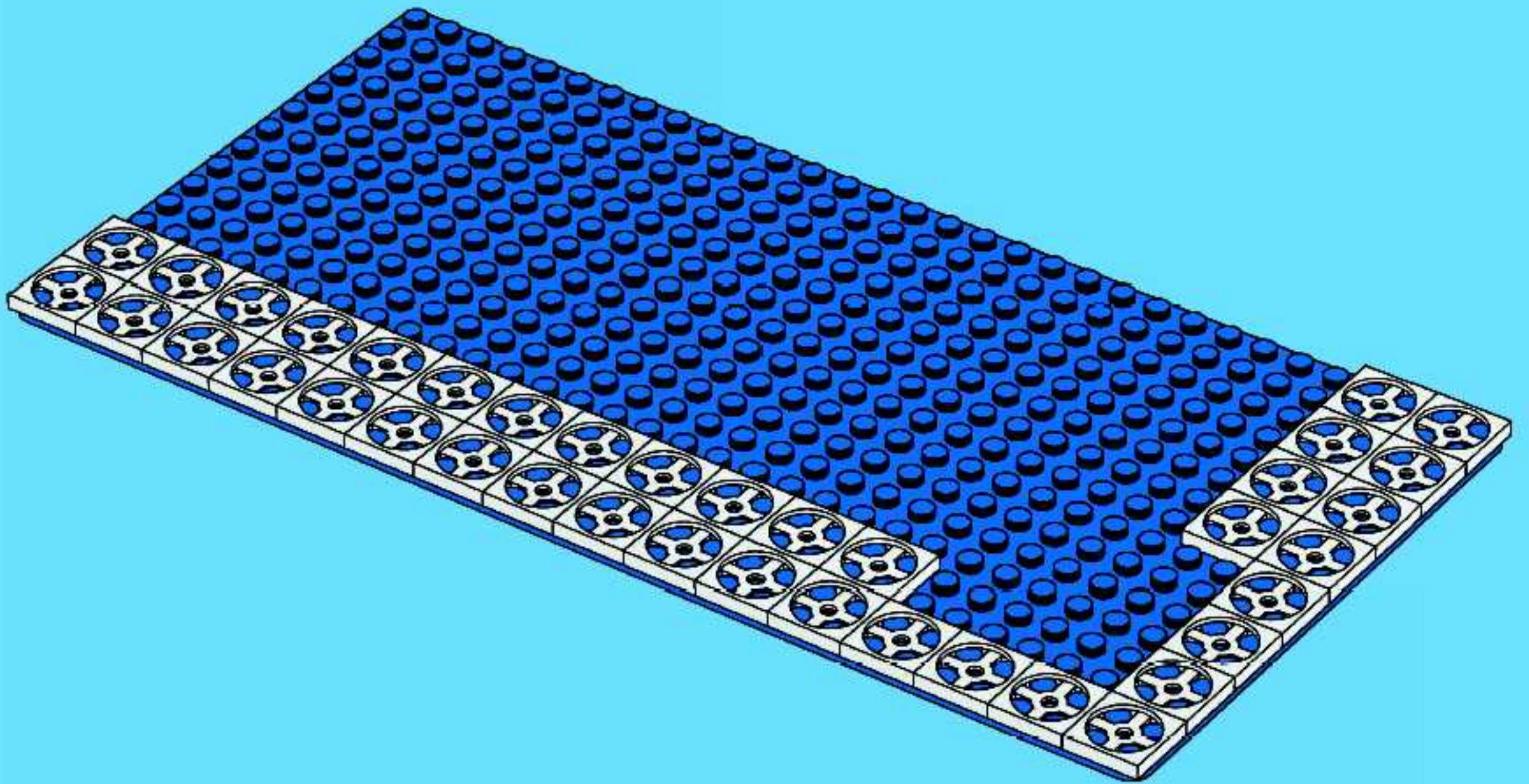



2

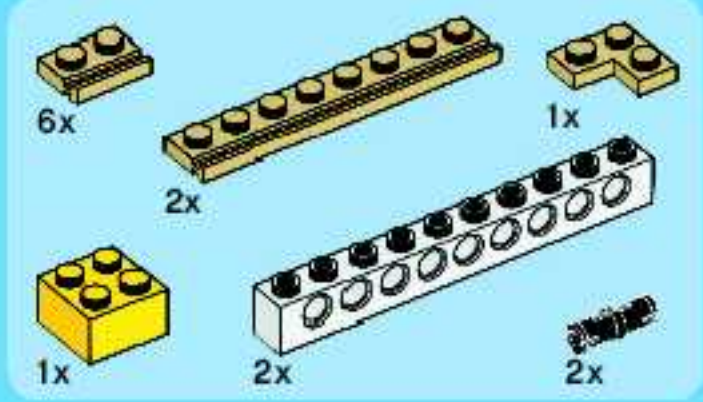
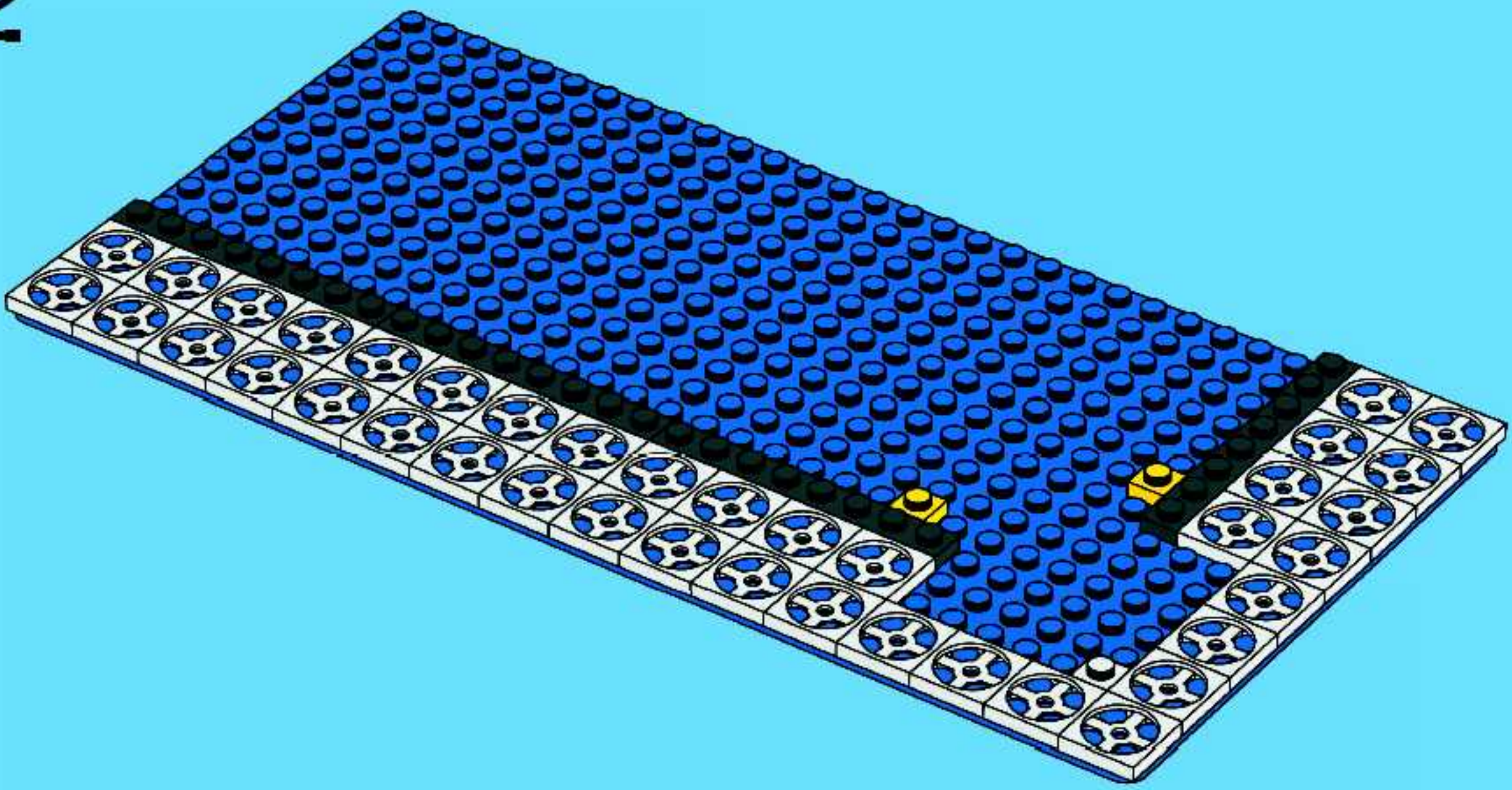

3

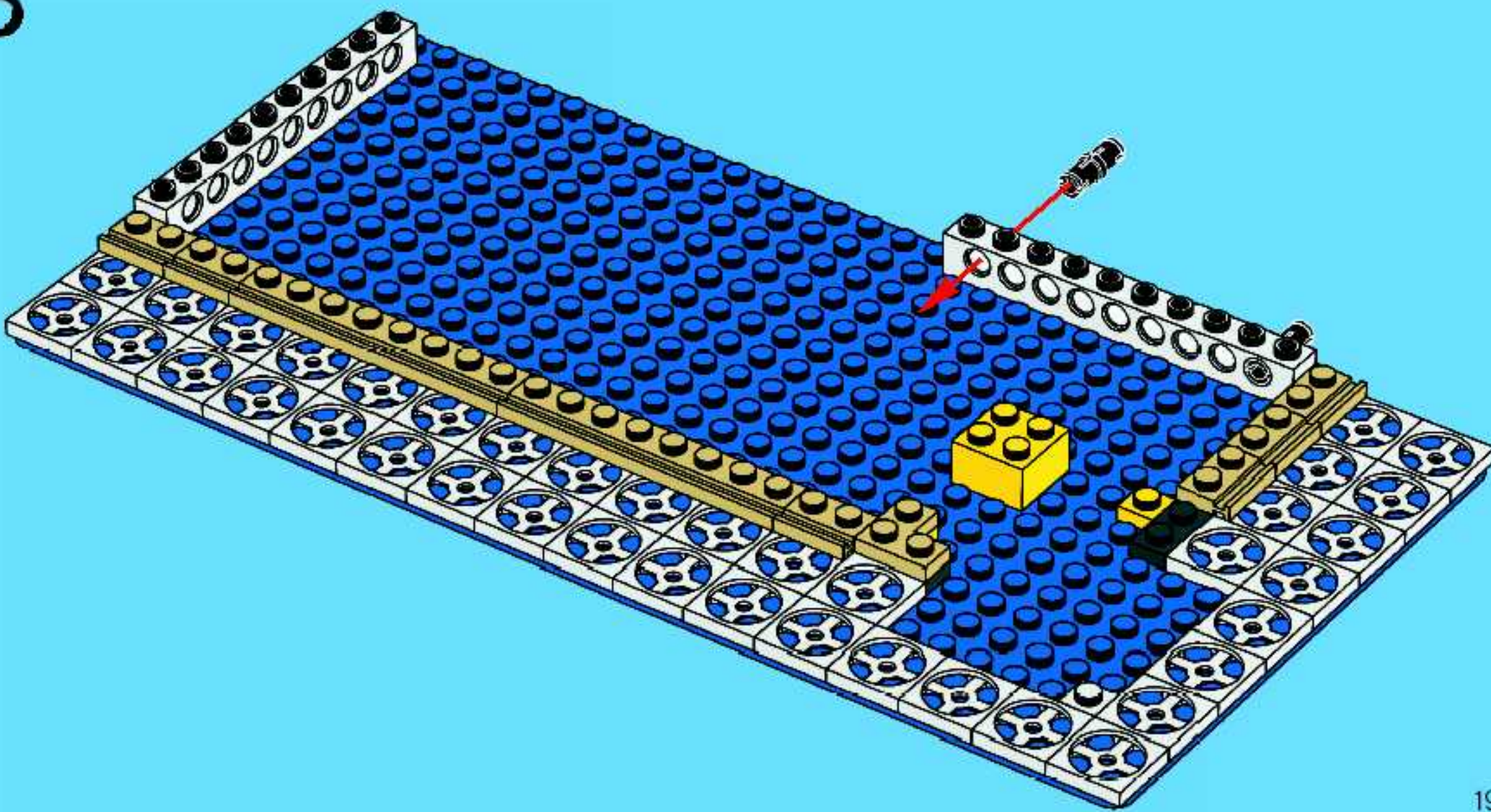

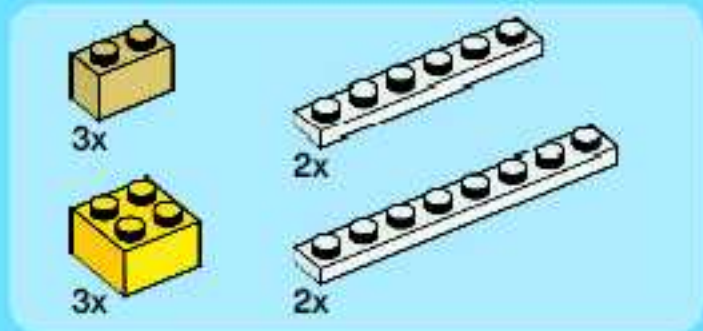

4

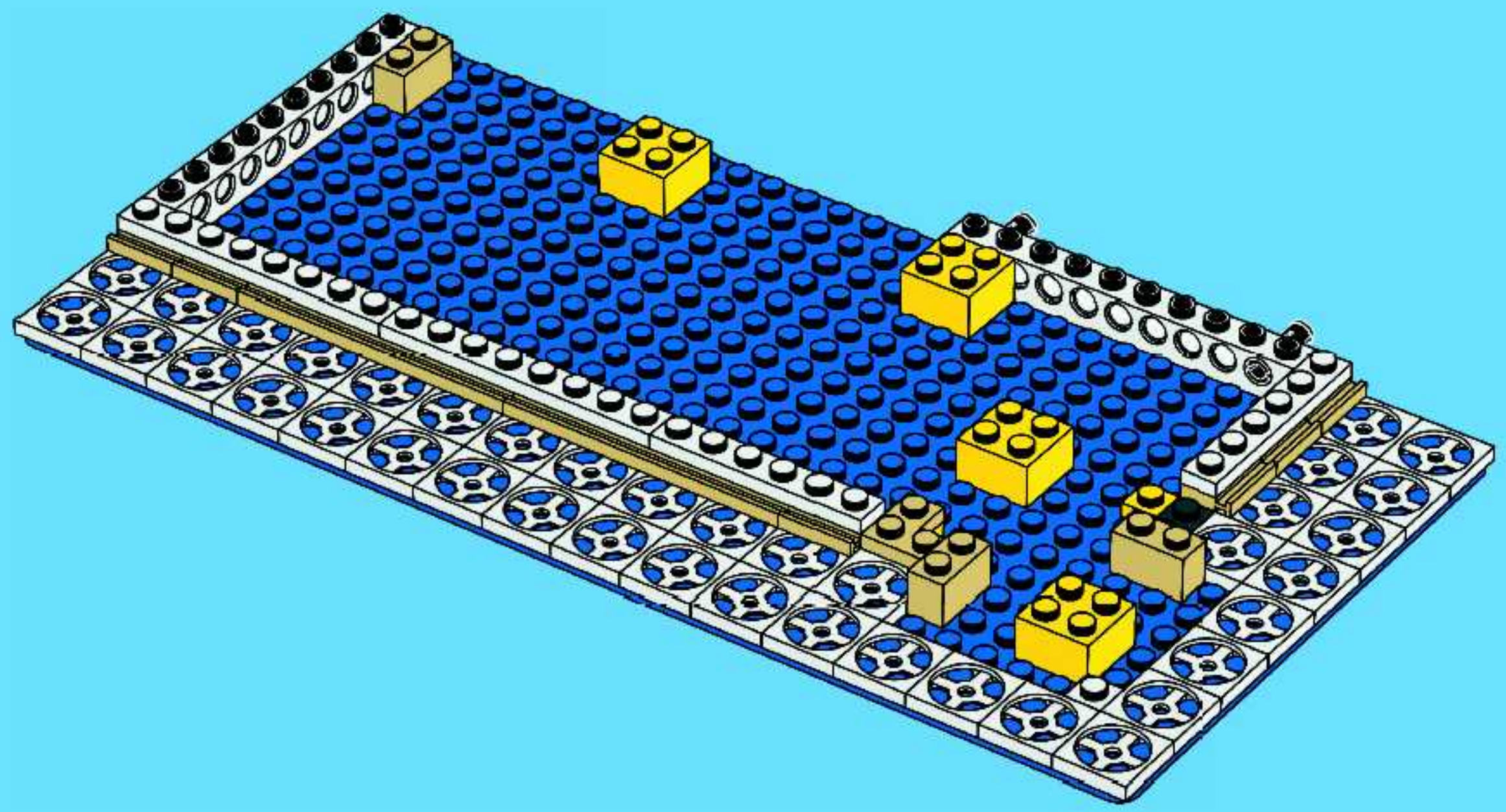



# 5

1



2



3



4

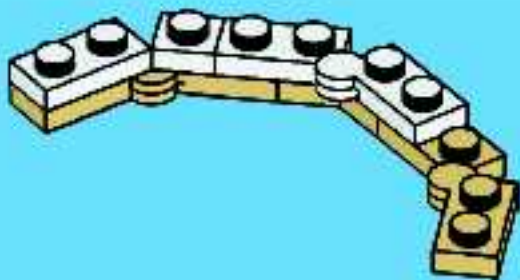

5

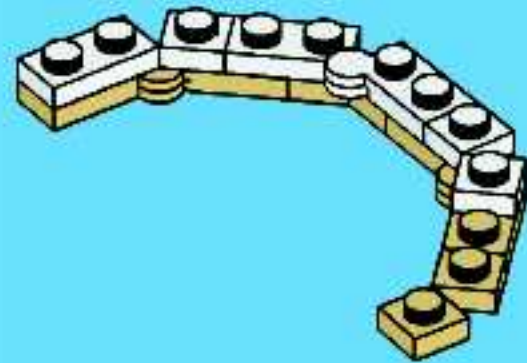

6

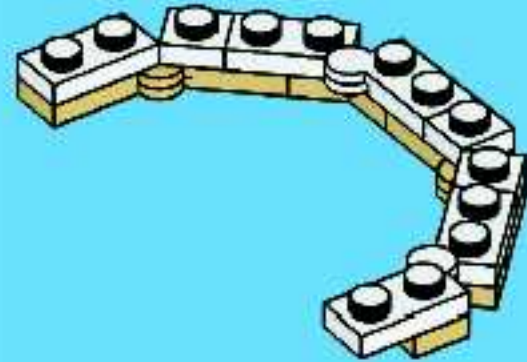

7

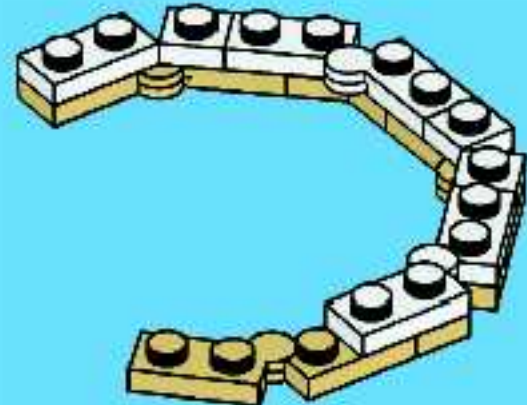

8

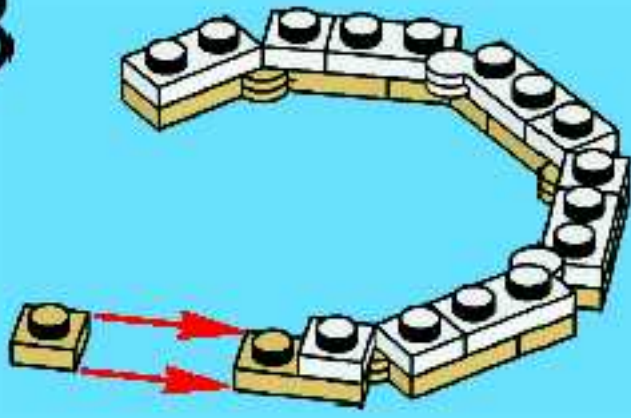

9

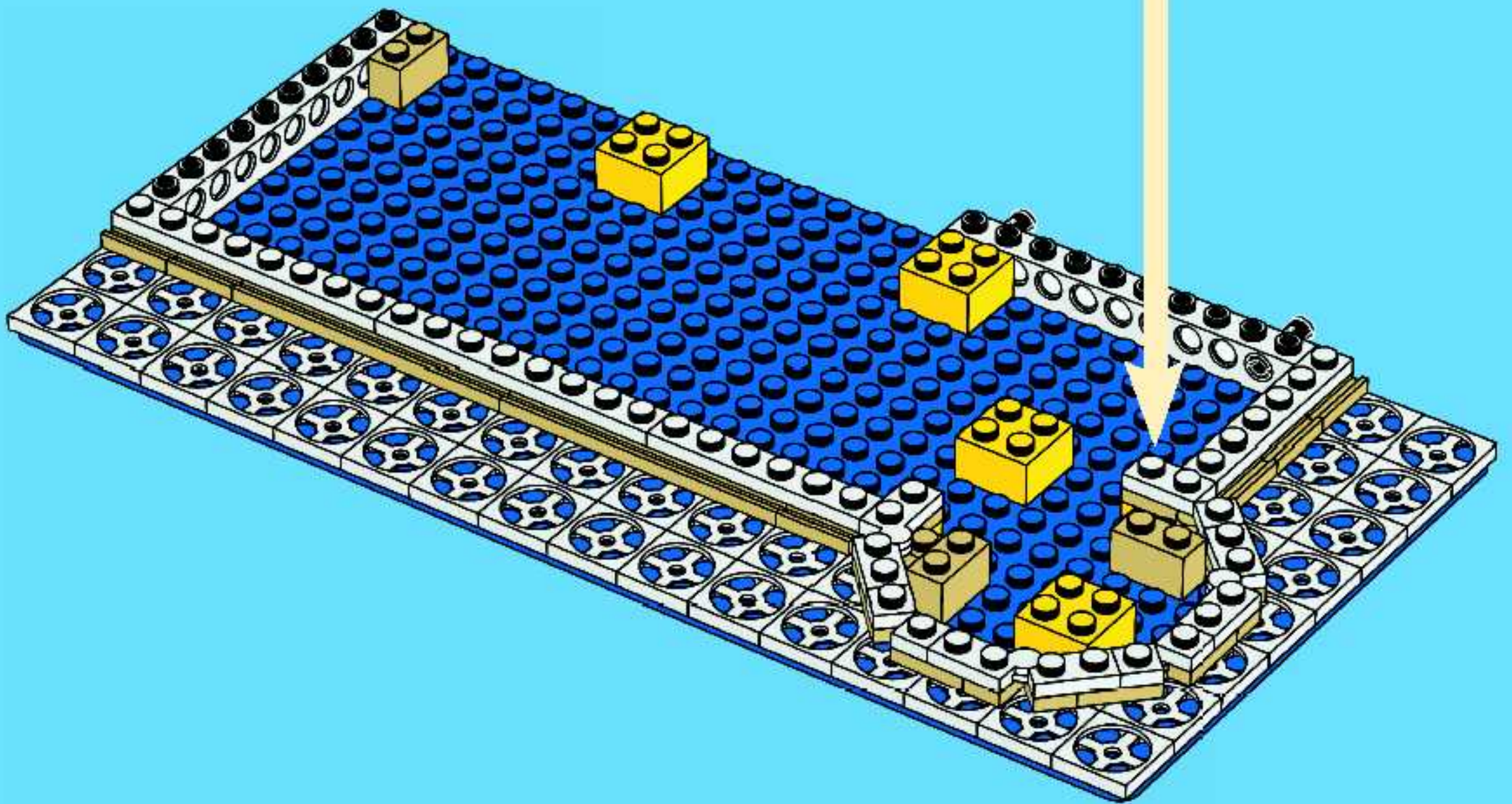
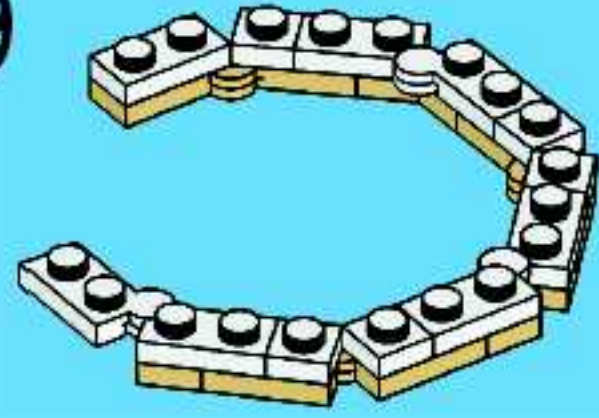

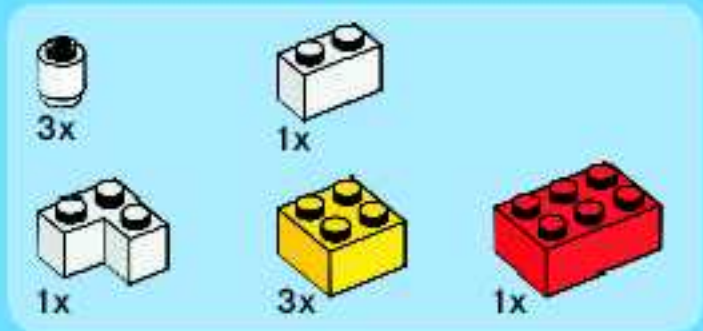

6

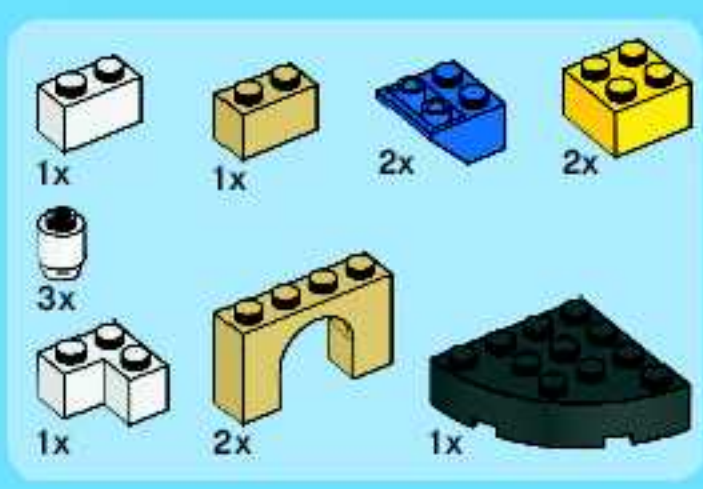
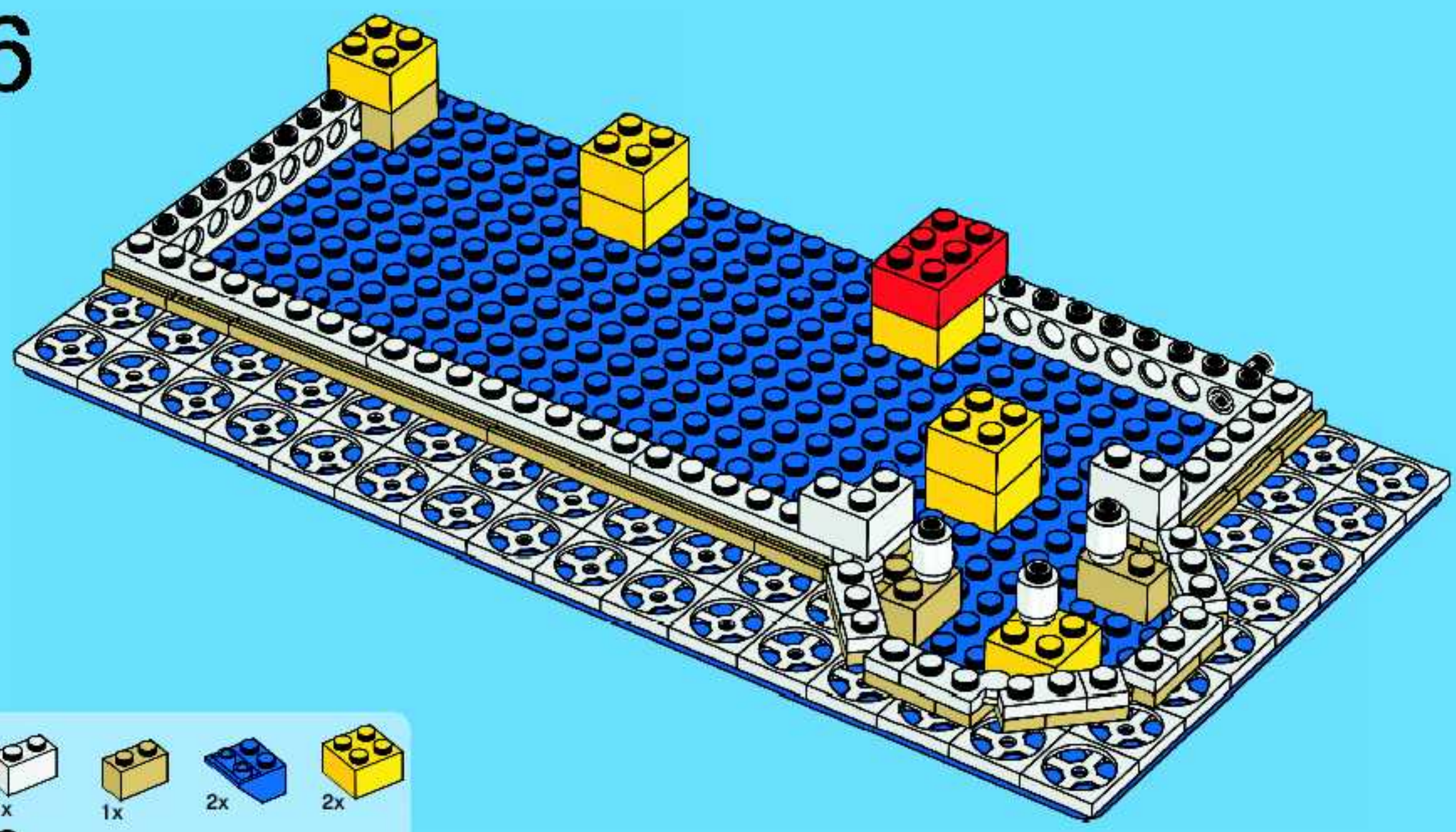

7





28x



14x

8

1

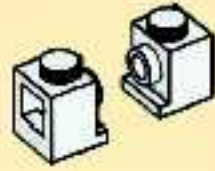

2

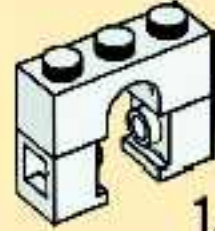

14x

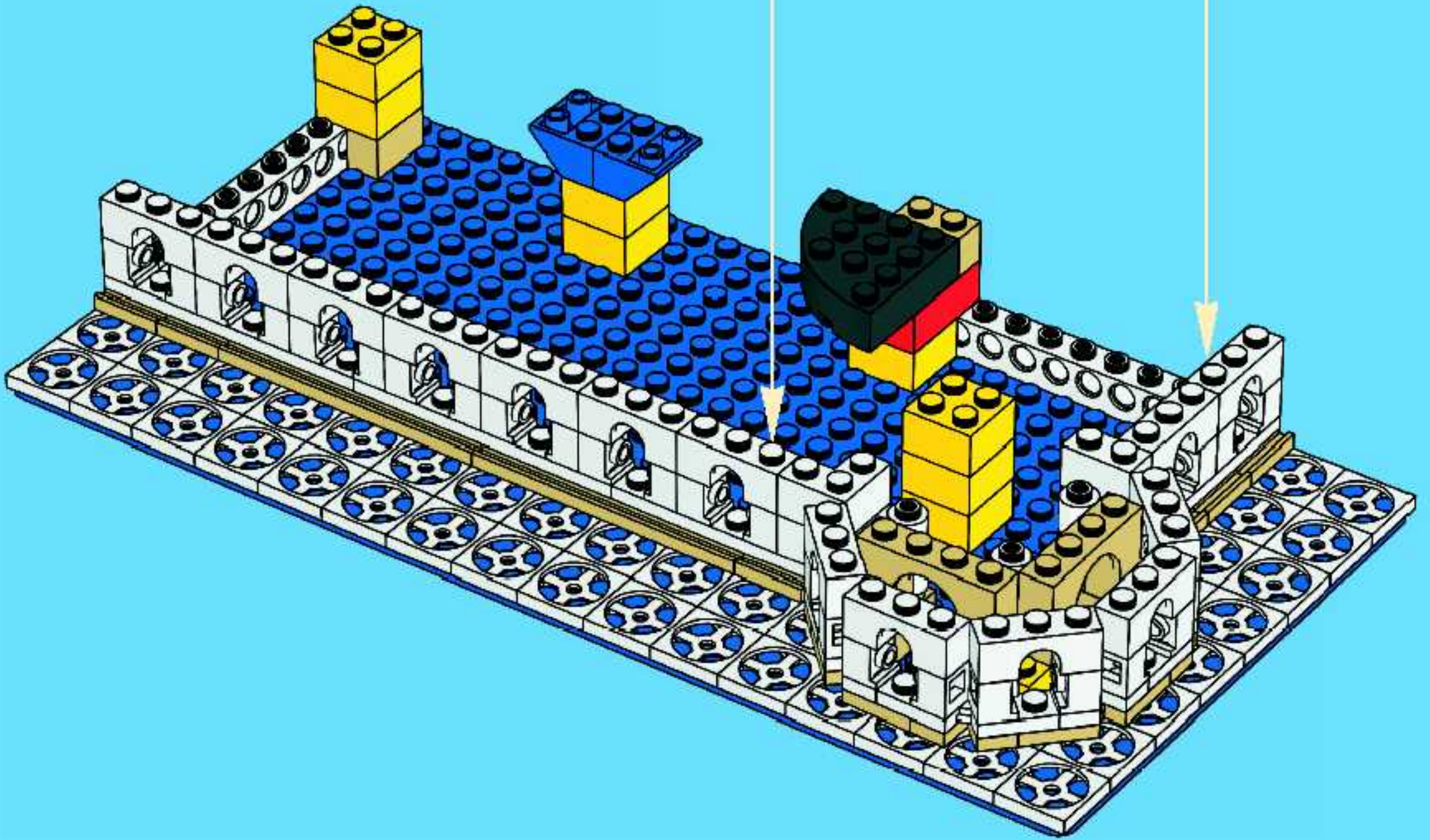



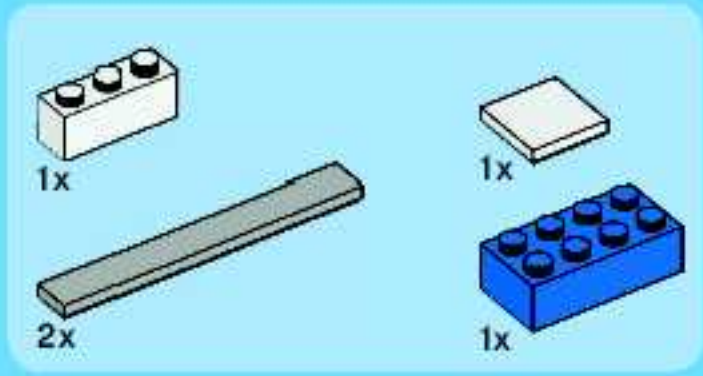

9

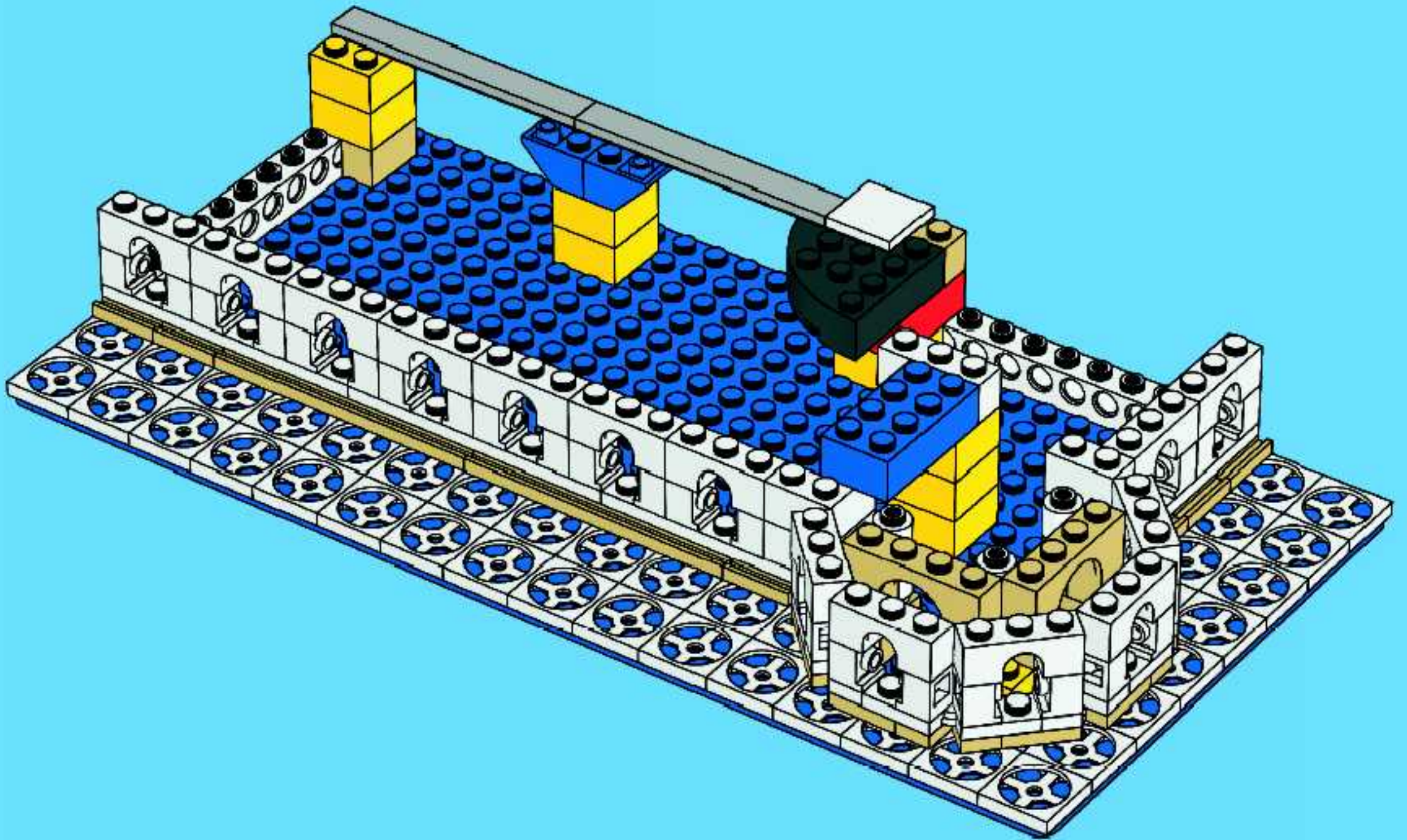

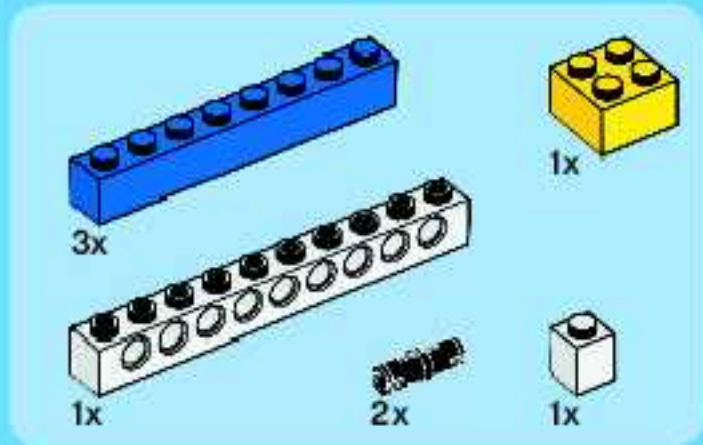

10

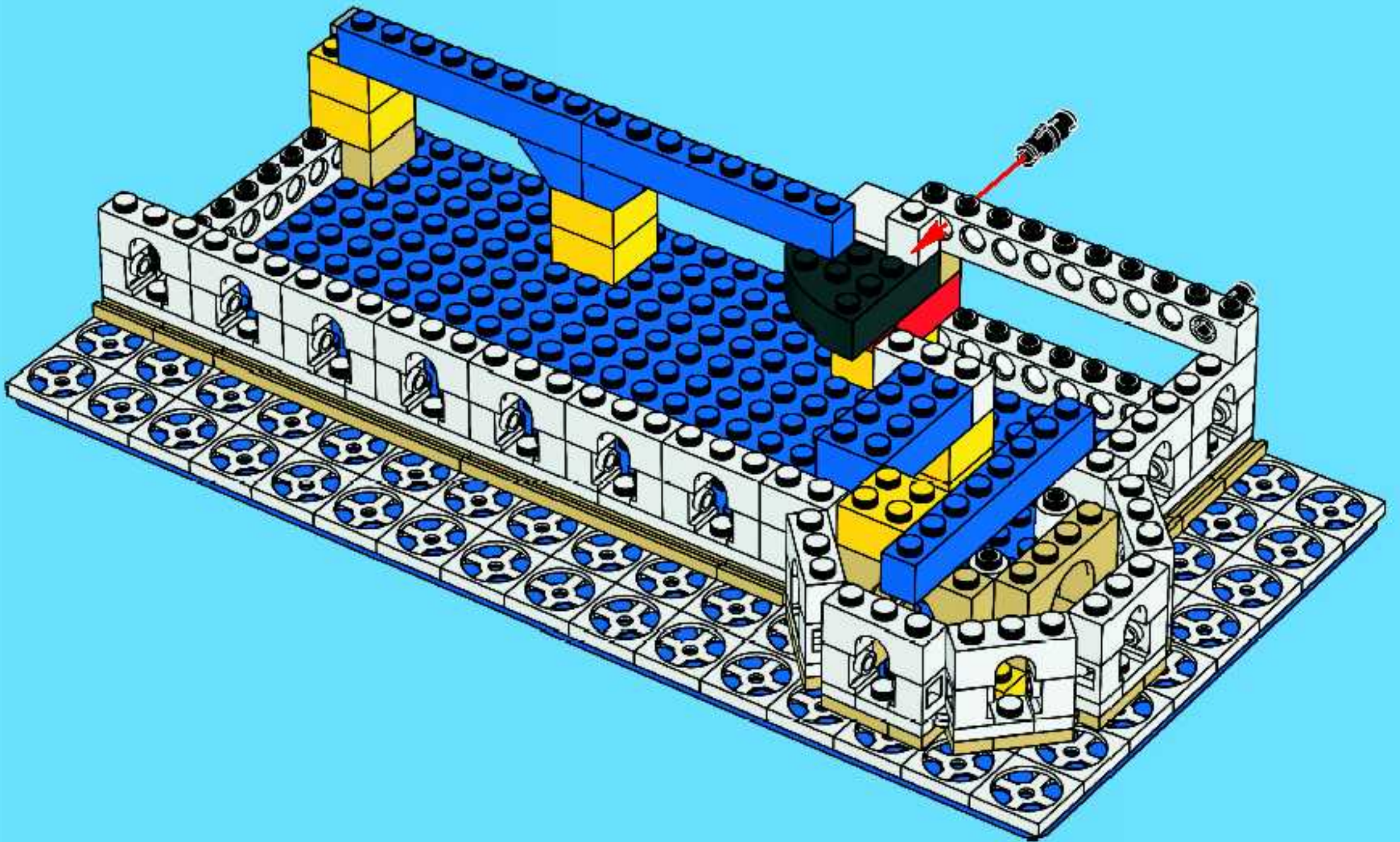

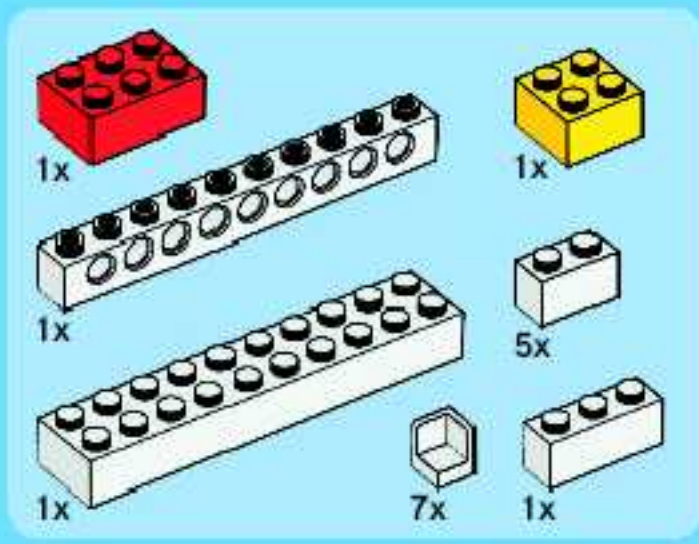

11

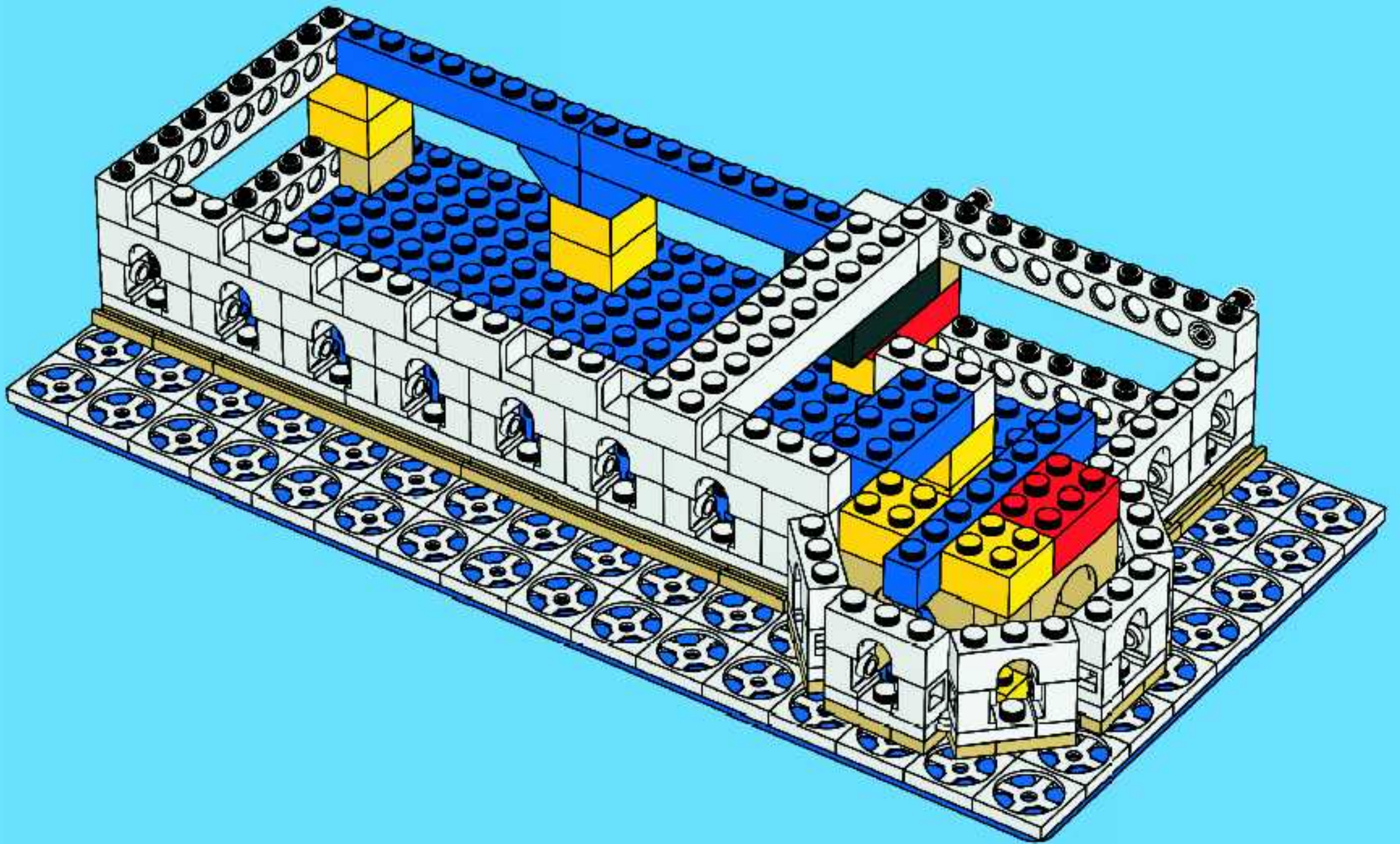



7x



10x



2x

# 12

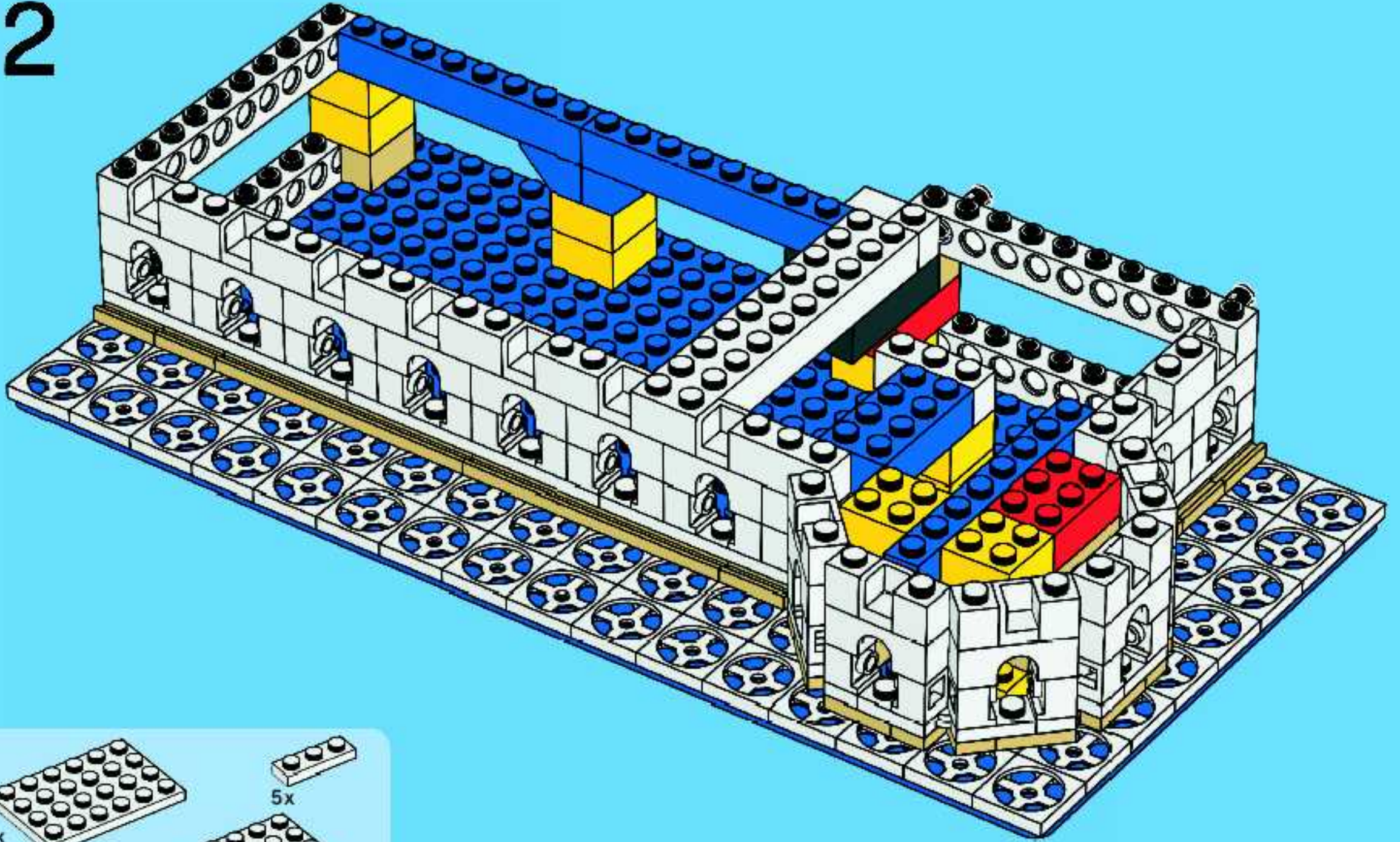

1x



5x



4x



2x

# 13

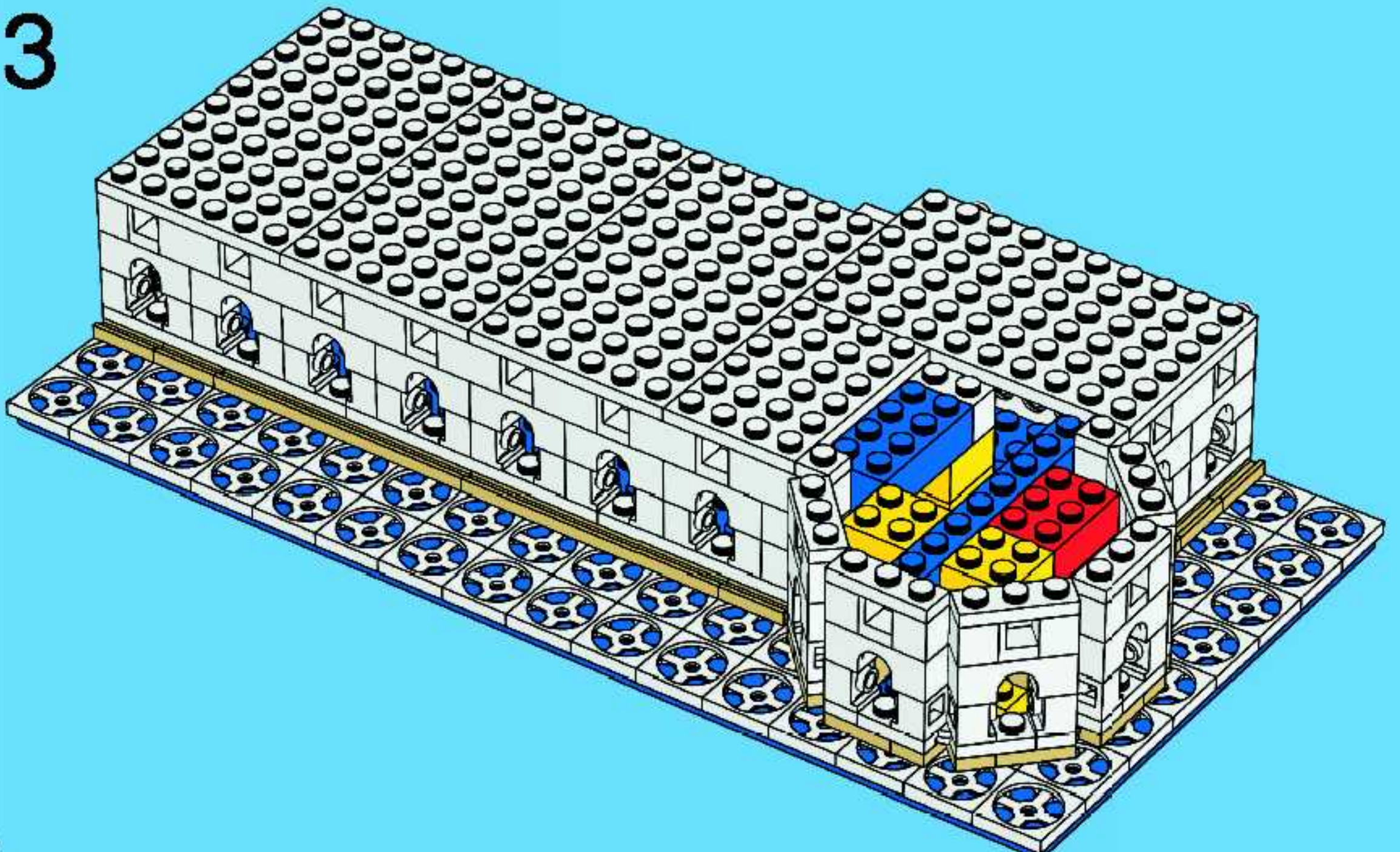

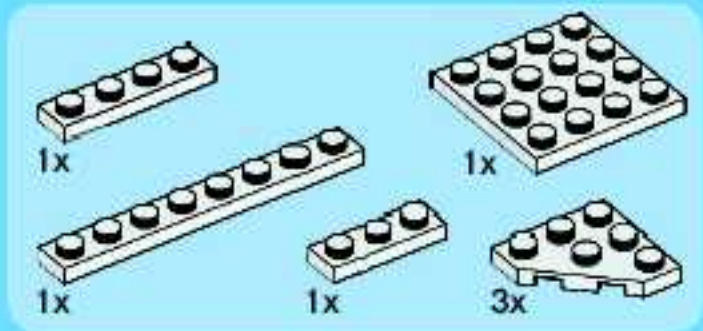

14

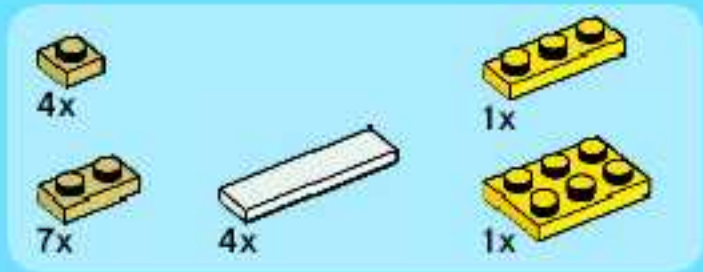
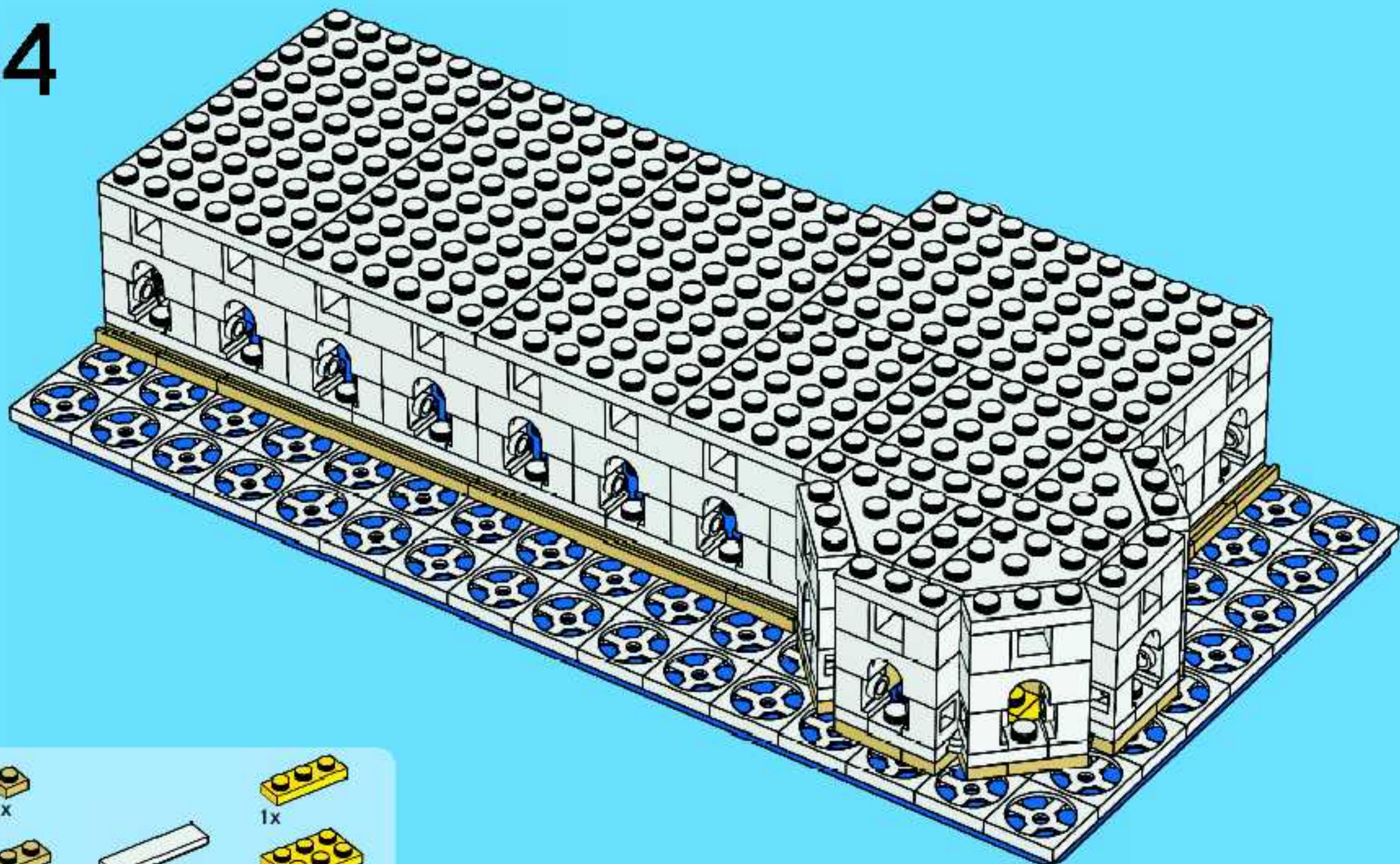

15

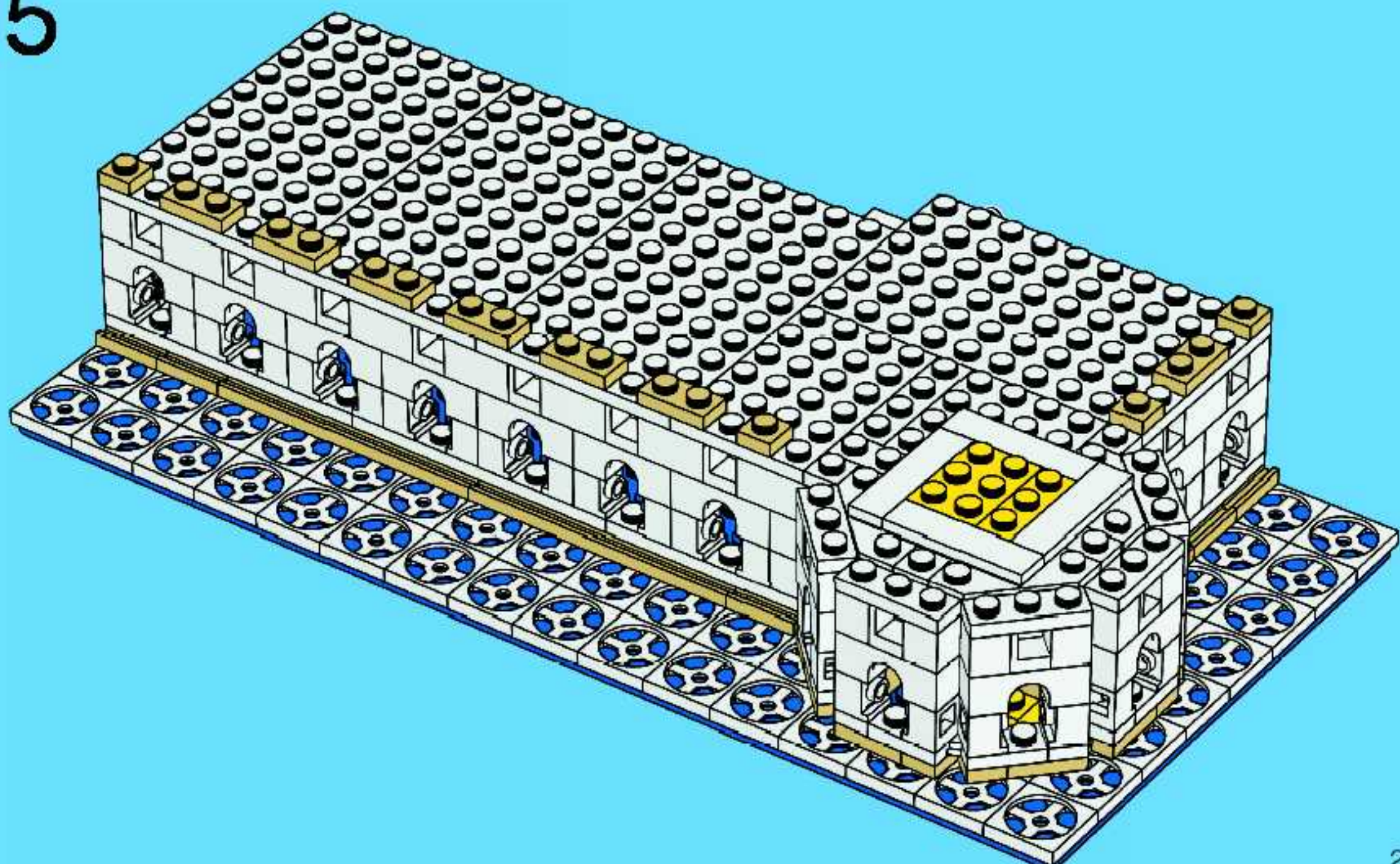



5x



1x



3x

# 16

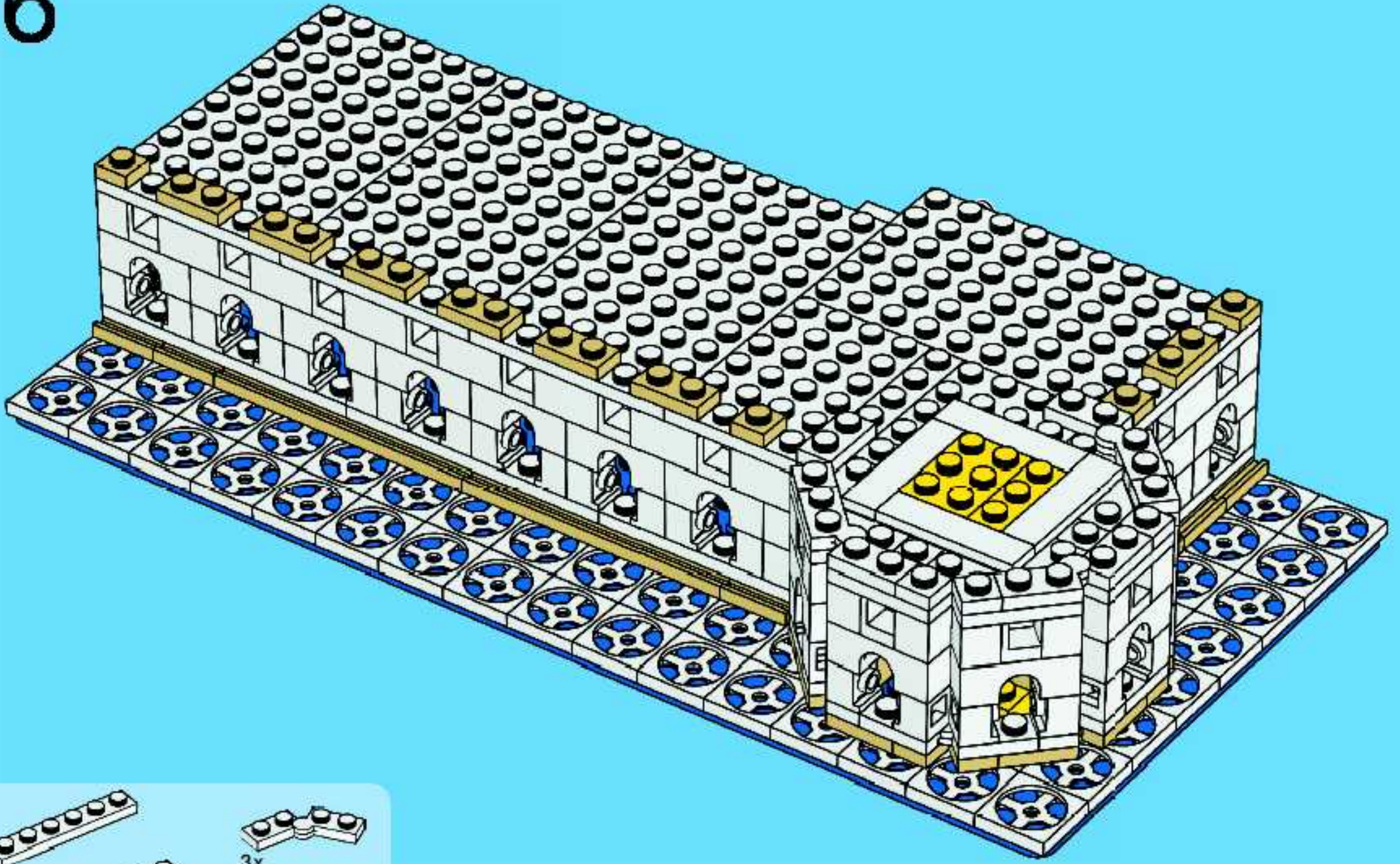

2x



3x

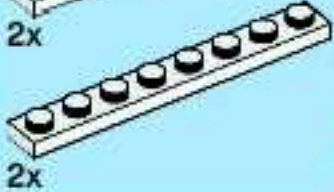

2x



5x



1x

# 17

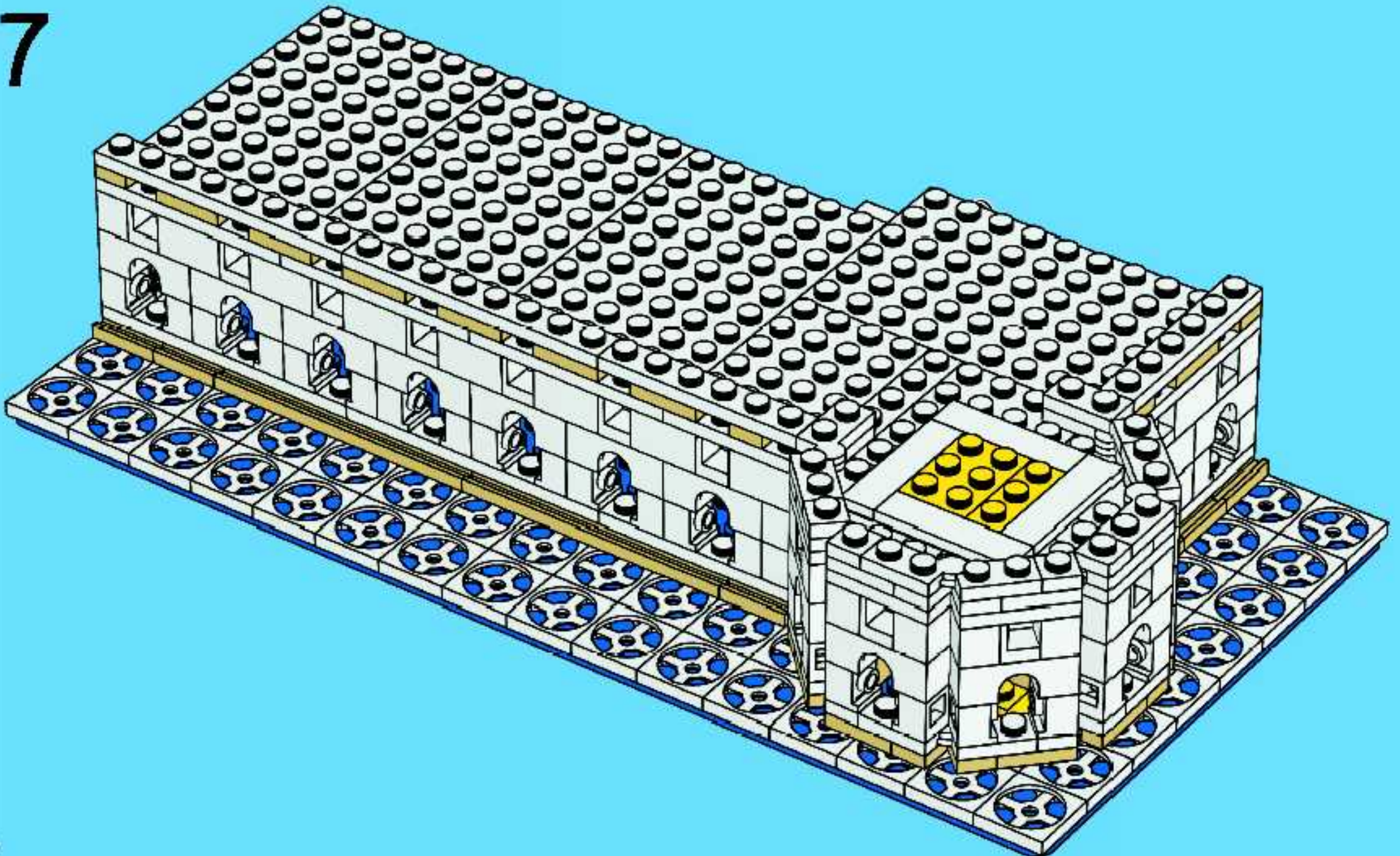

30x

18

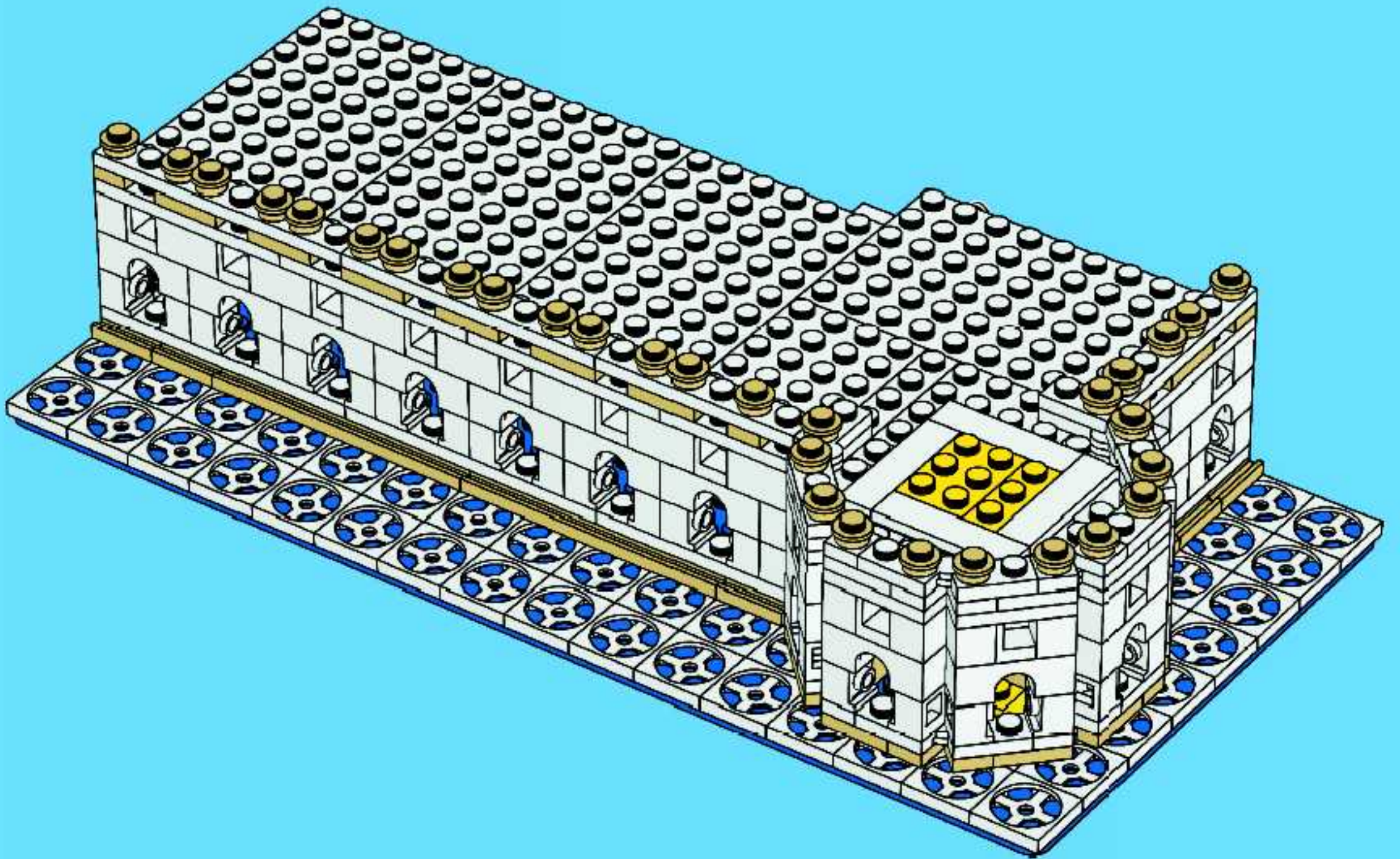

2x

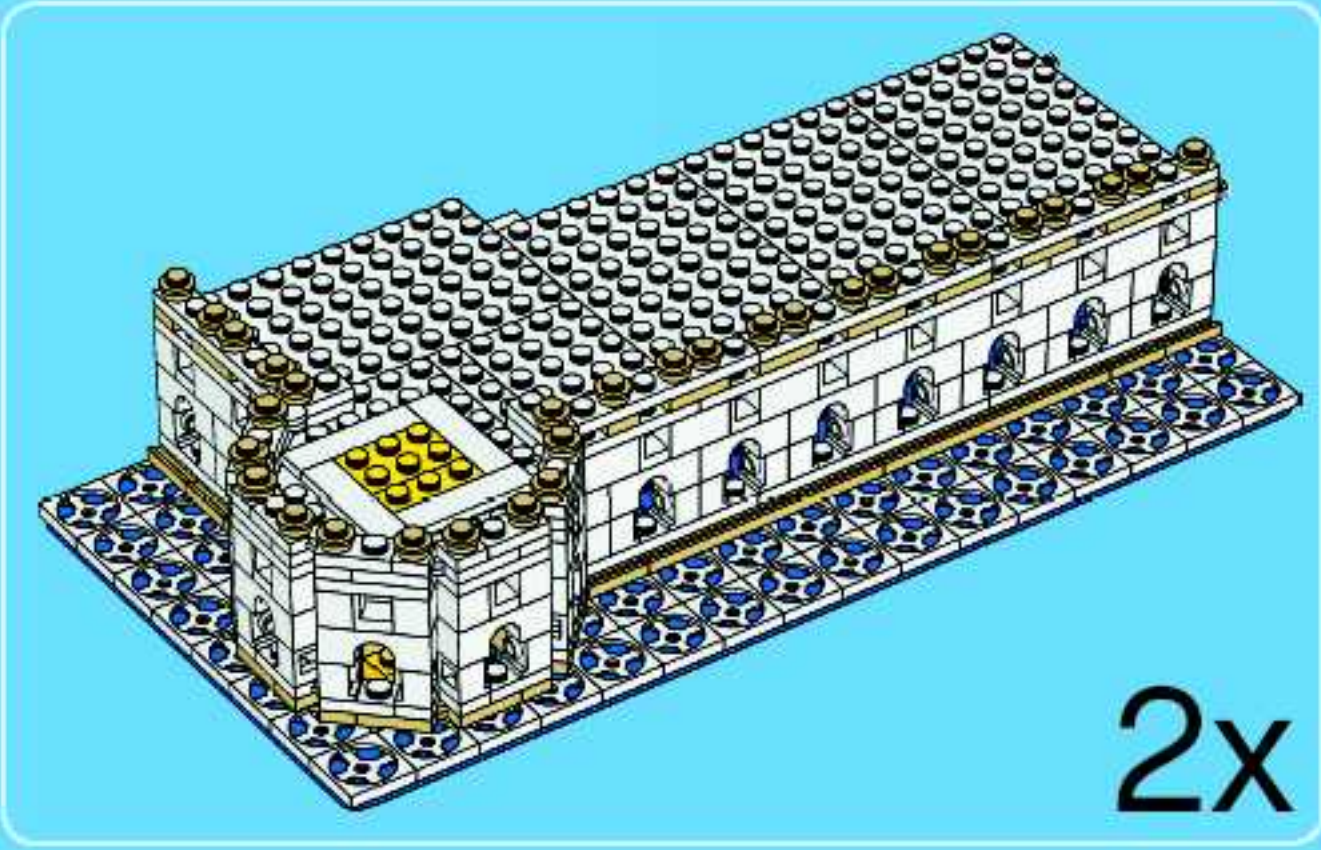

1

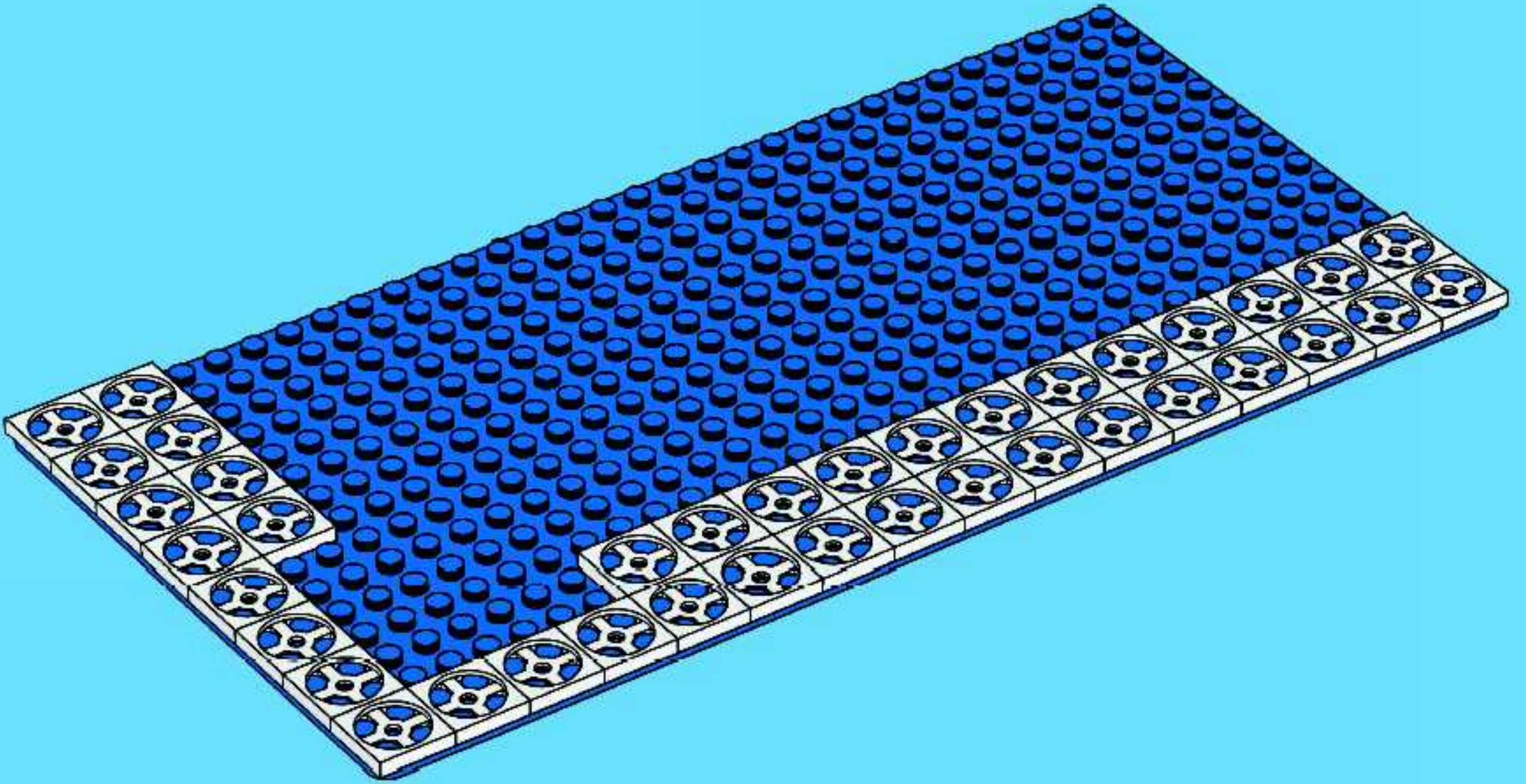





2

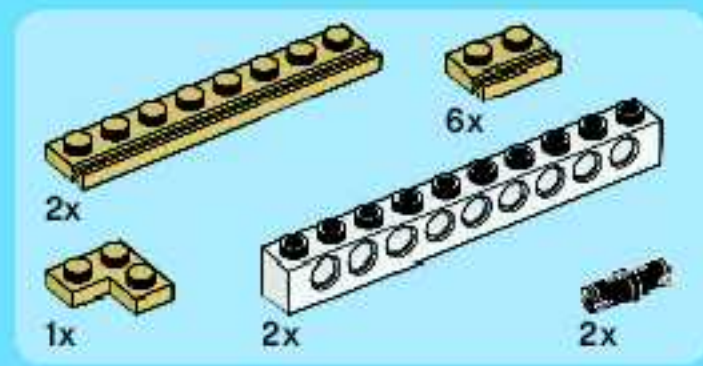
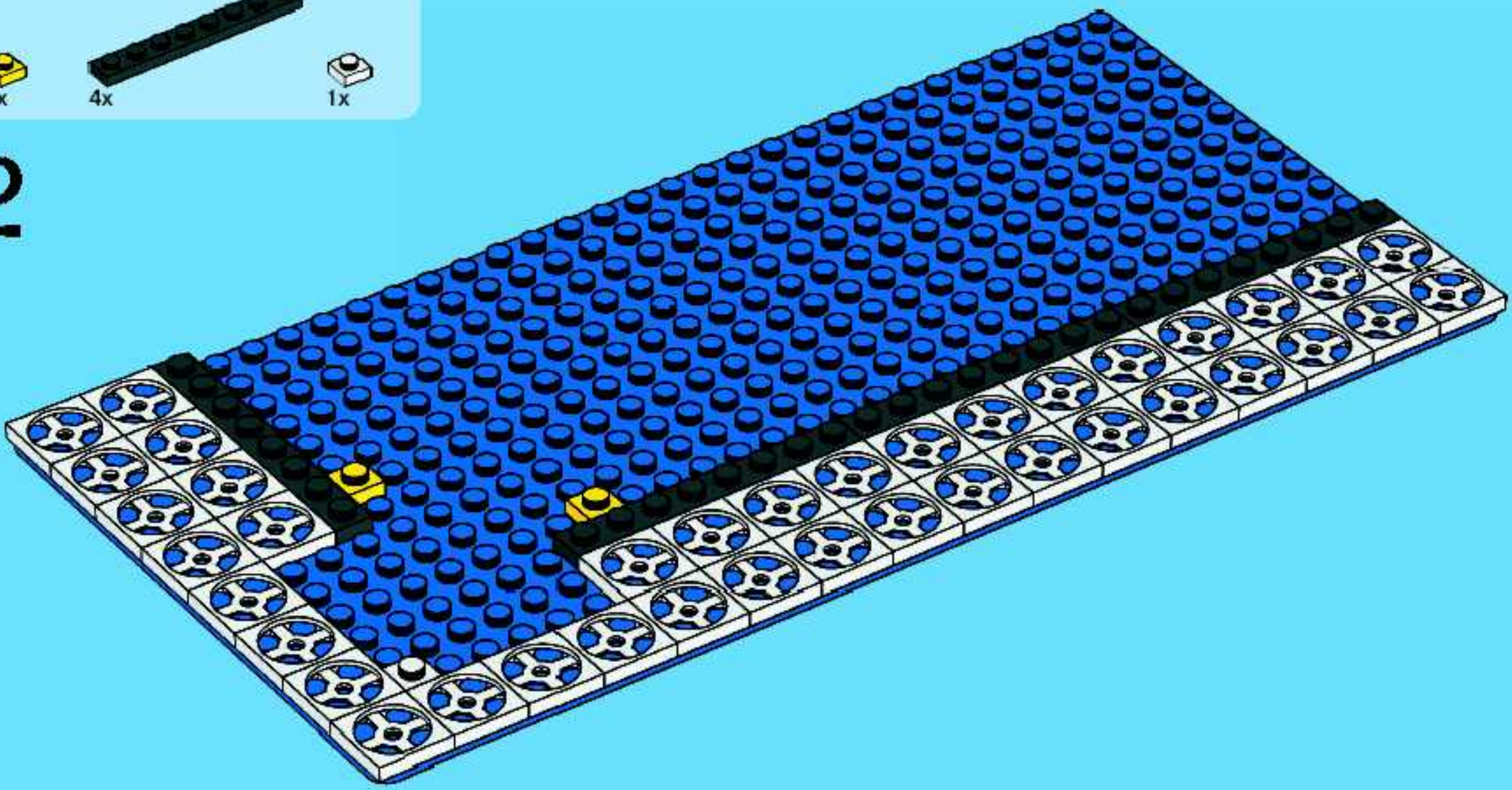

3

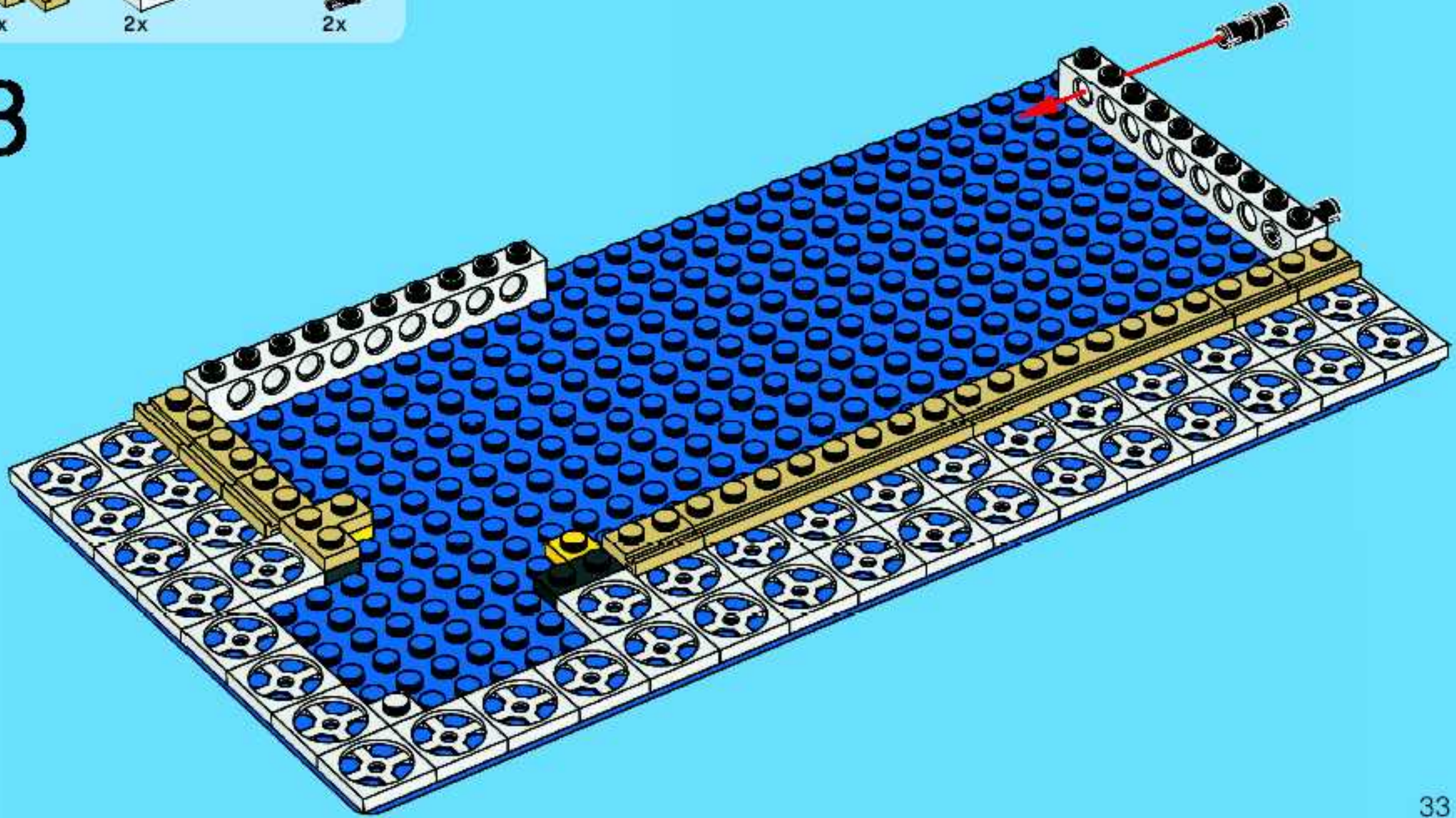

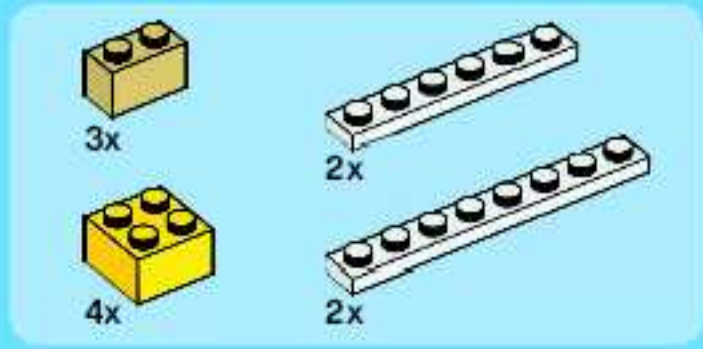

4

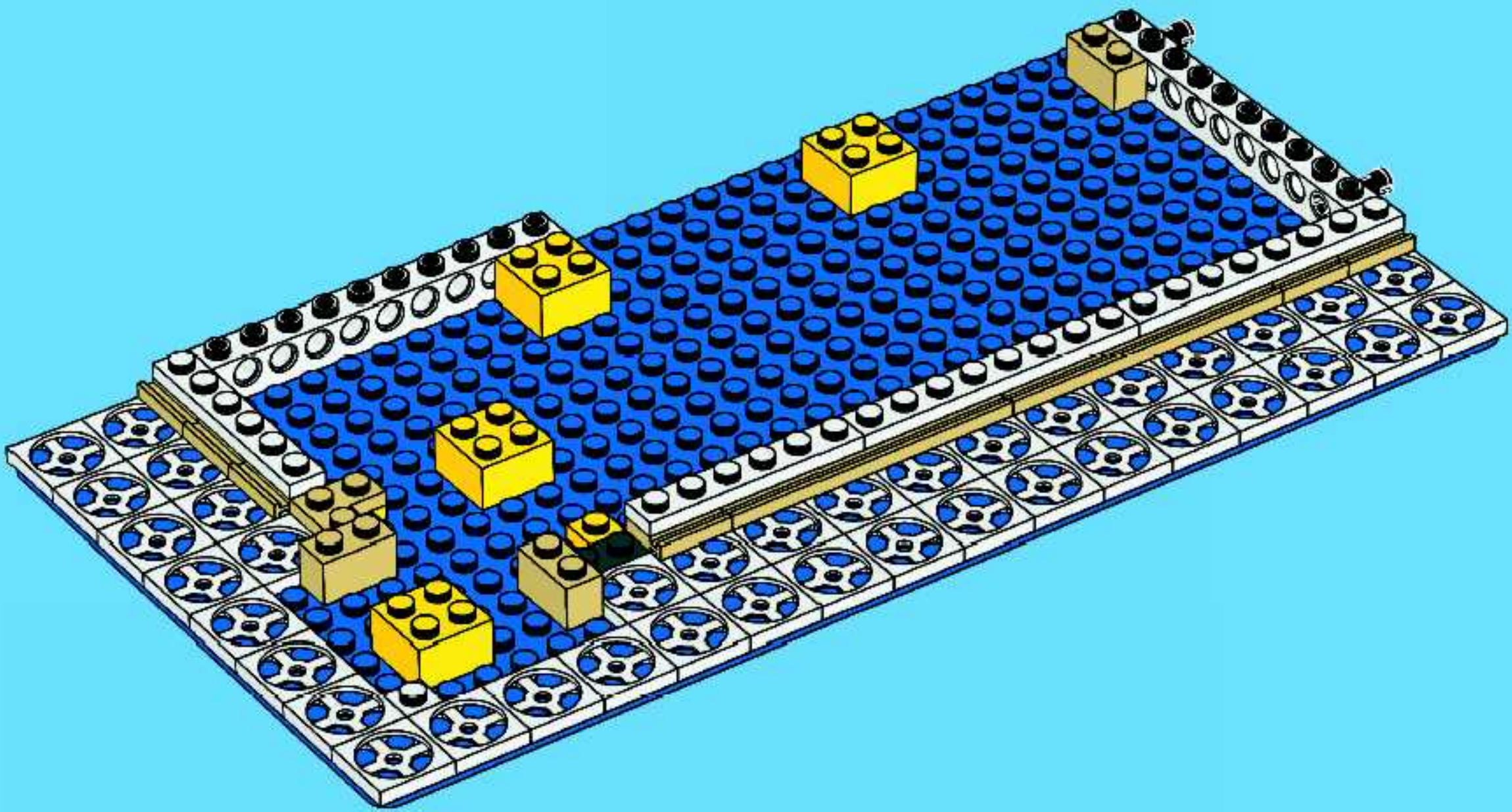



# 5

- 1
- 2
- 3
- 4

- 5
- 6
- 7

8

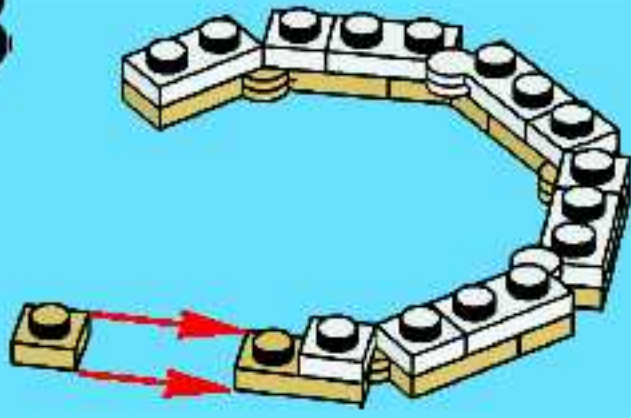

9

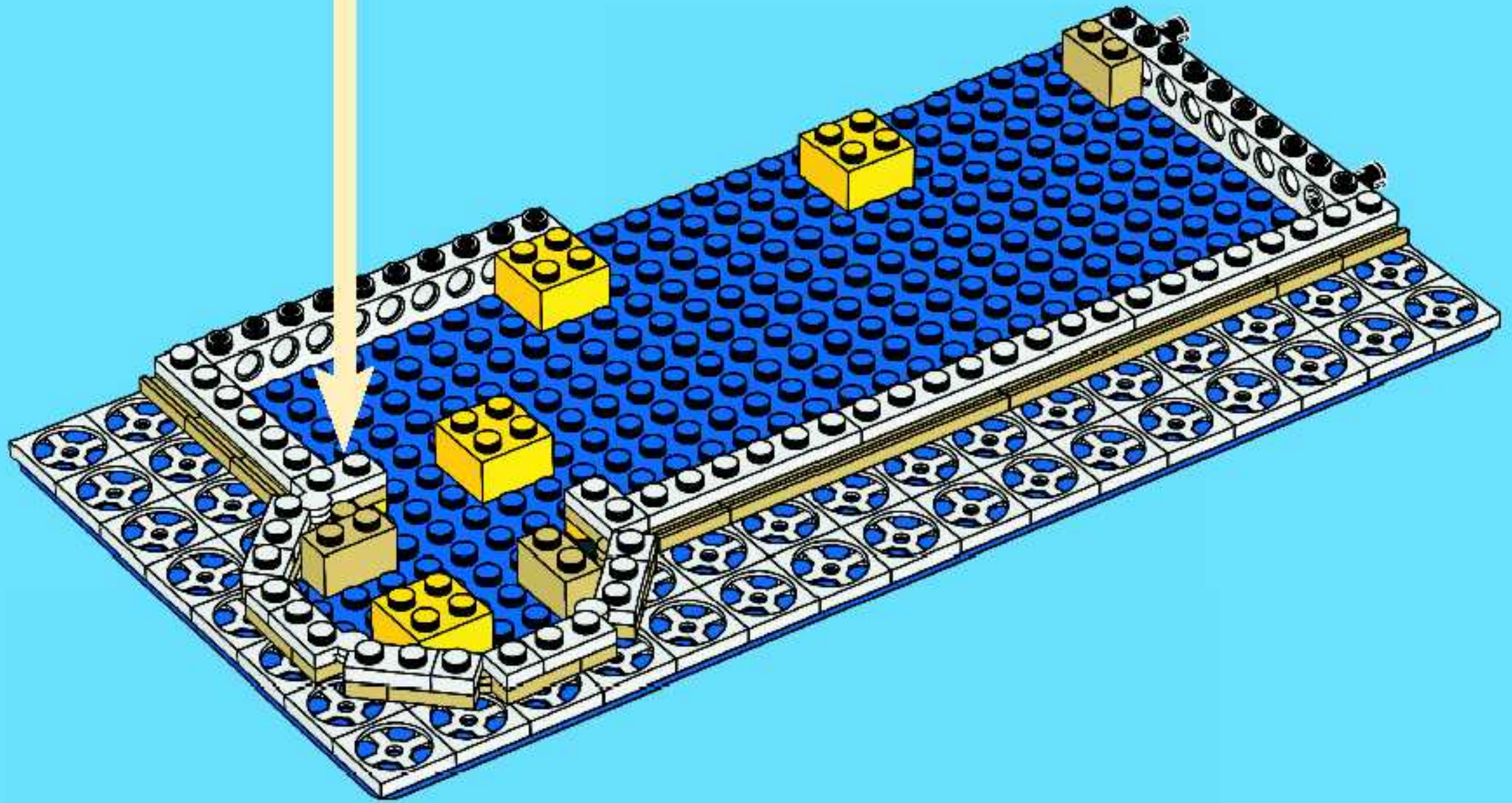
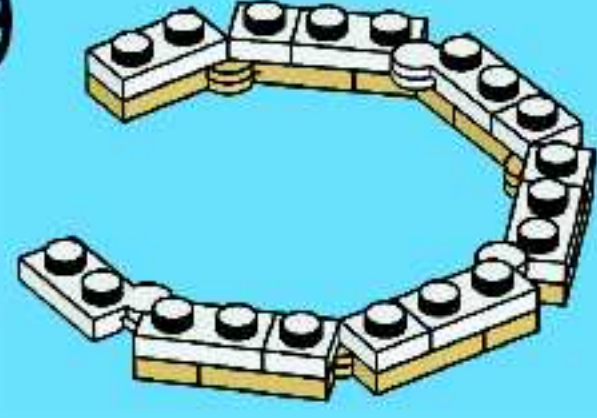

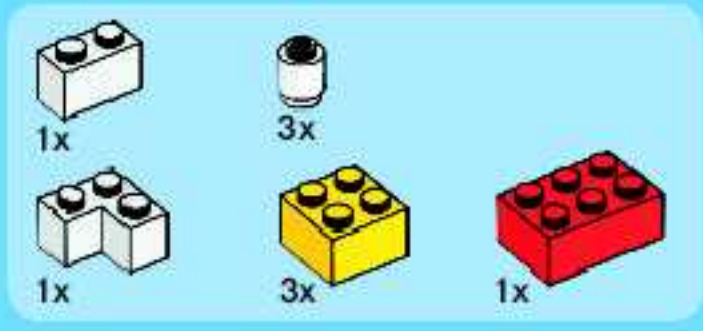

6

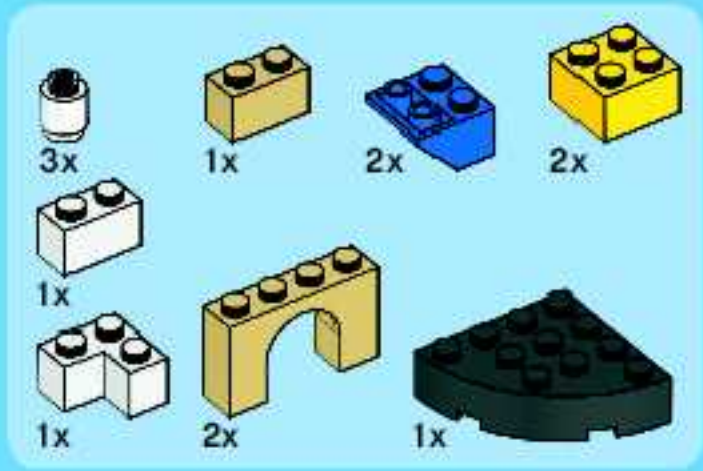
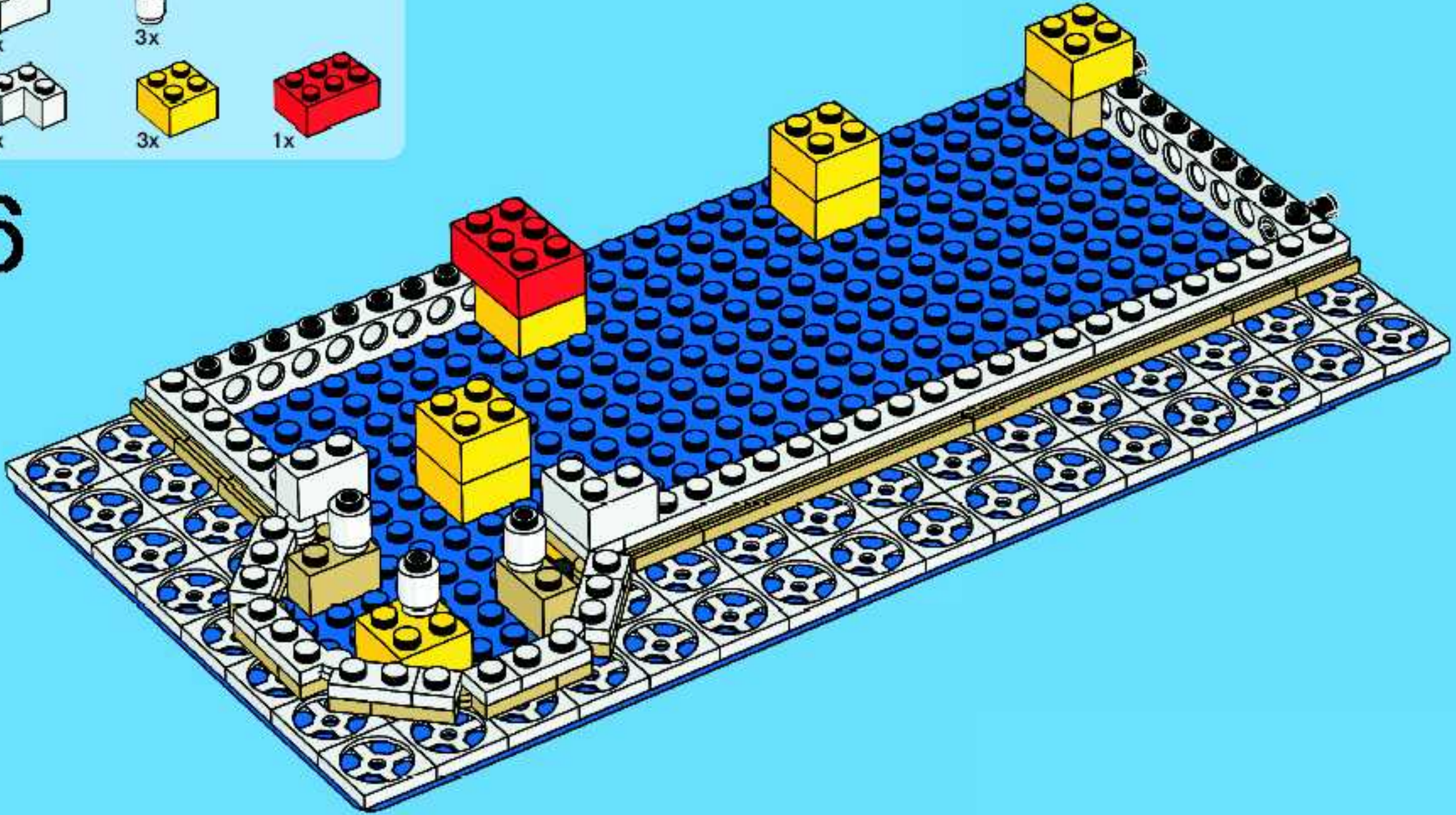

7

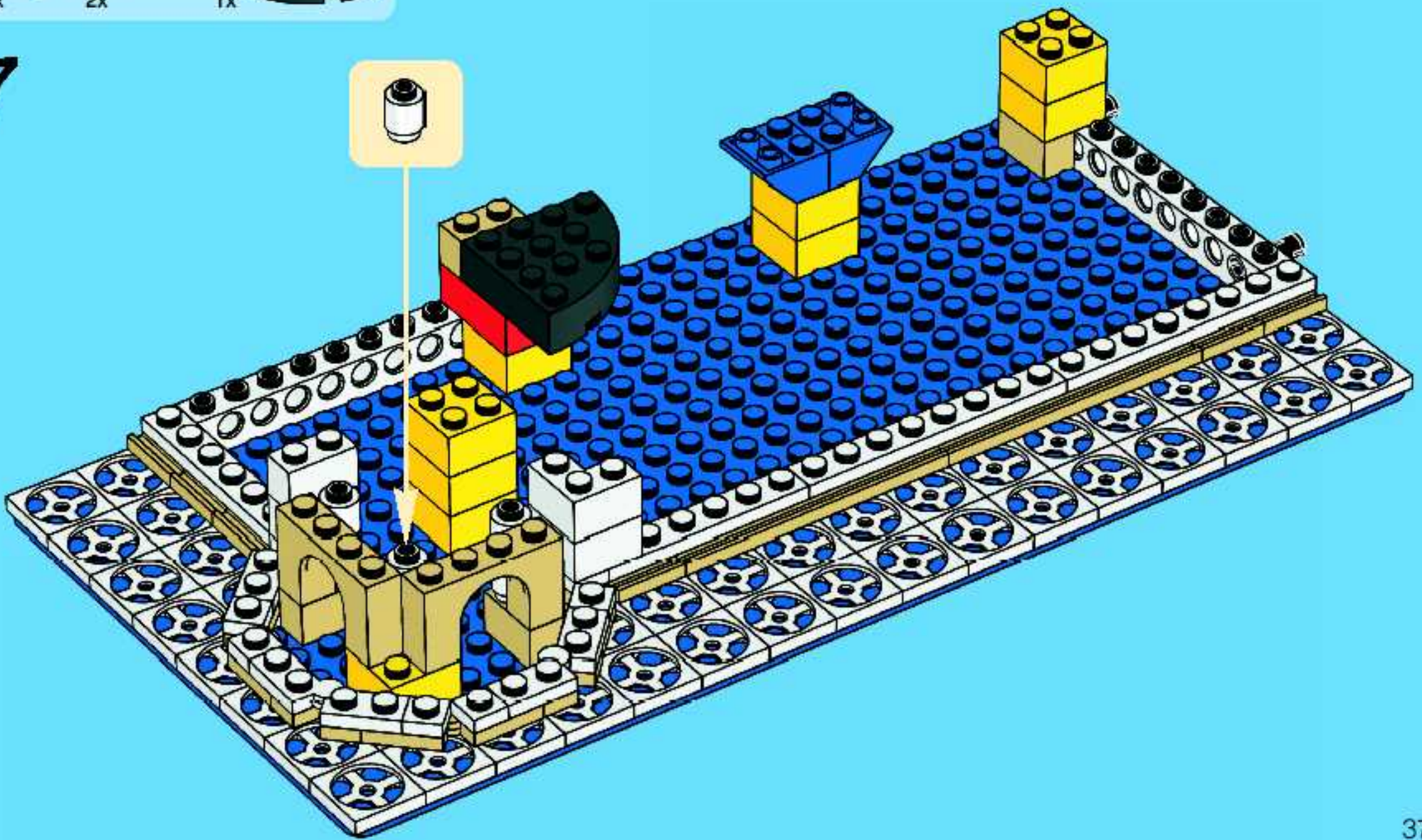



28x



14x

1



2

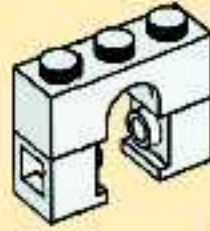

14x

8

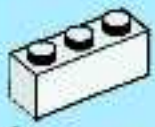
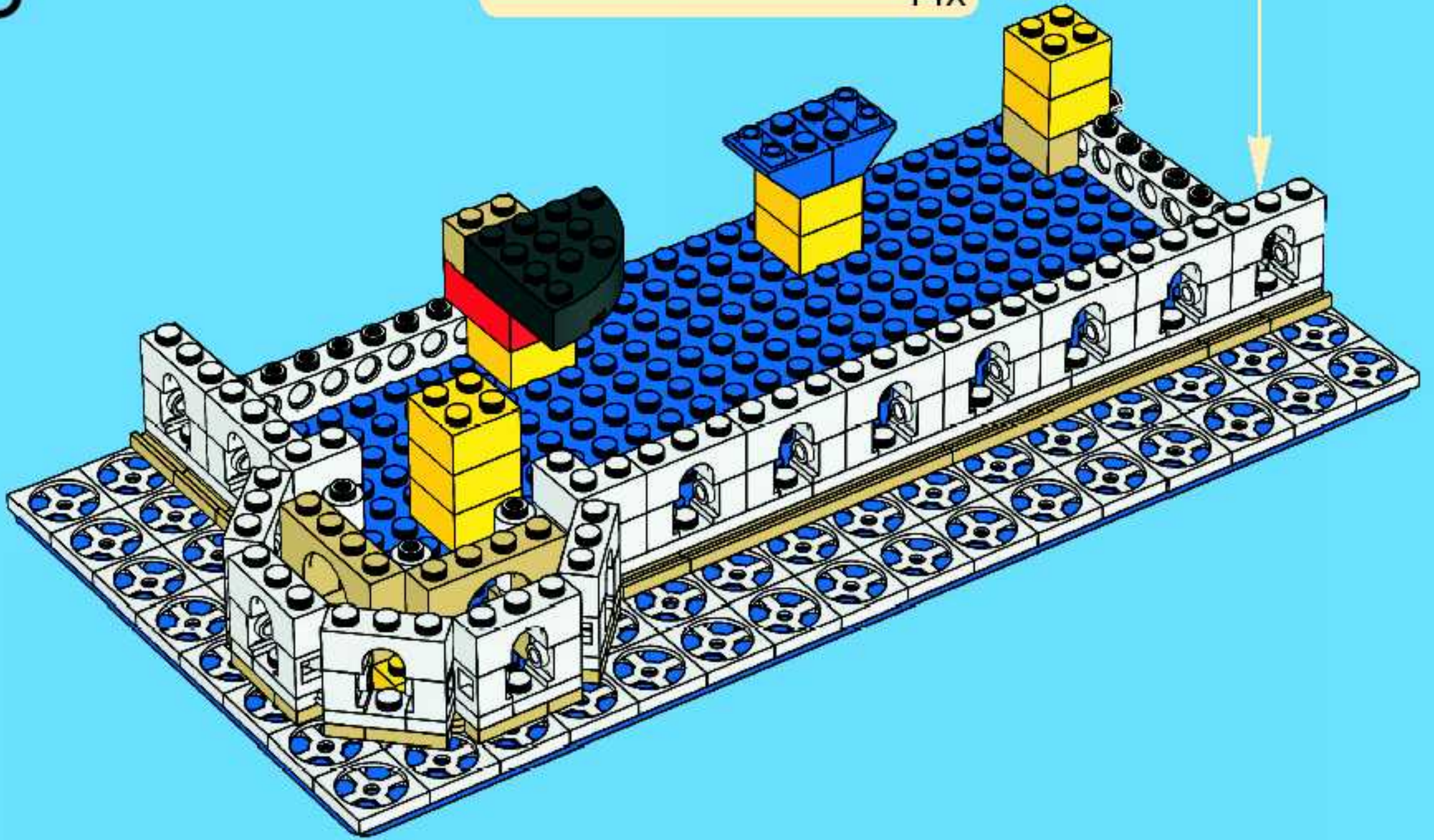

1x

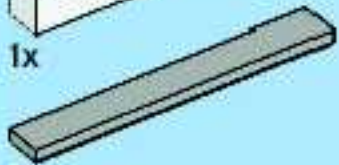

2x



1x



1x



1x



2x

9

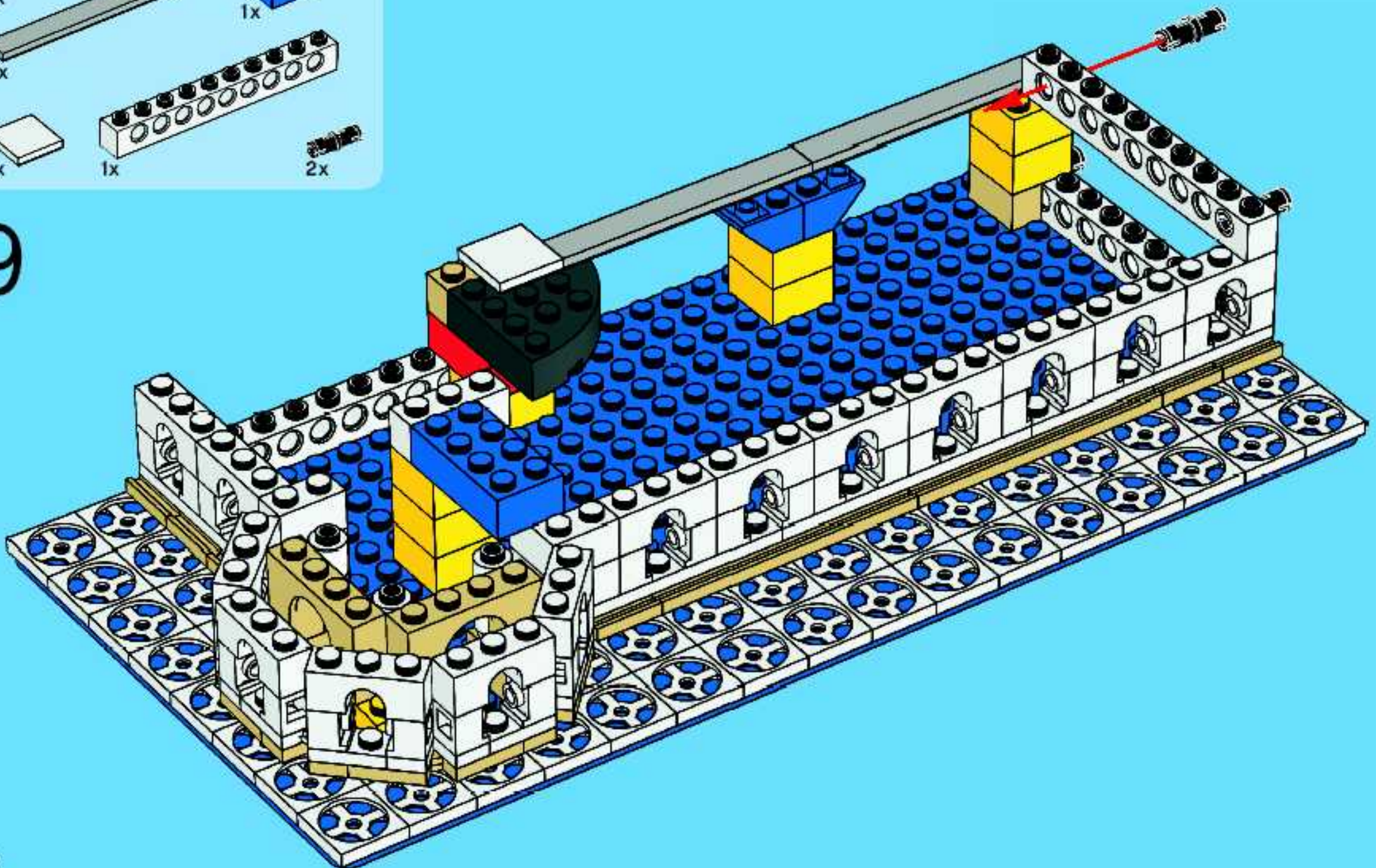

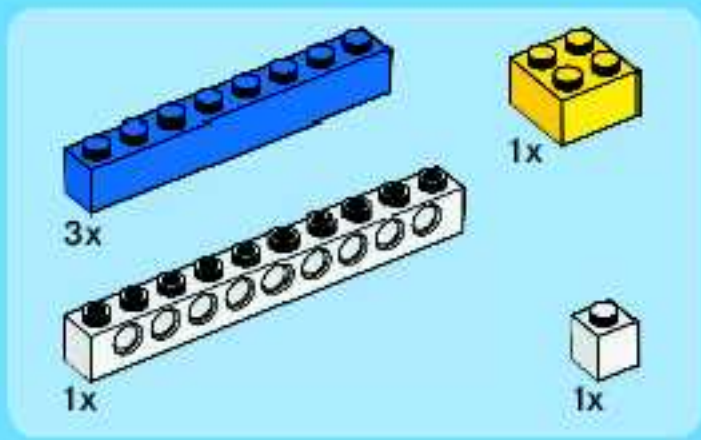

10

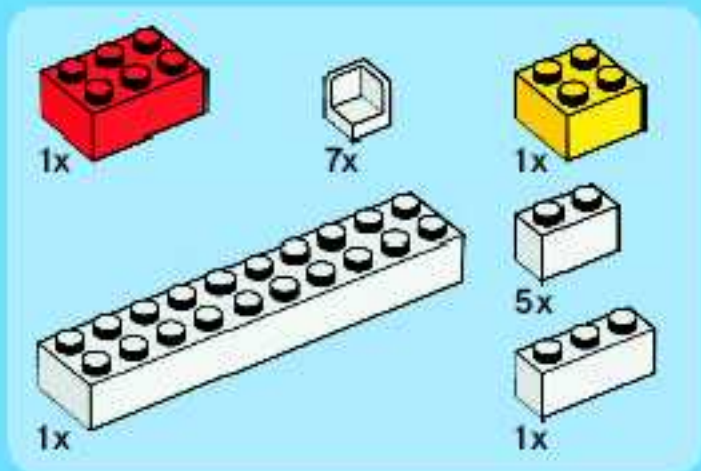
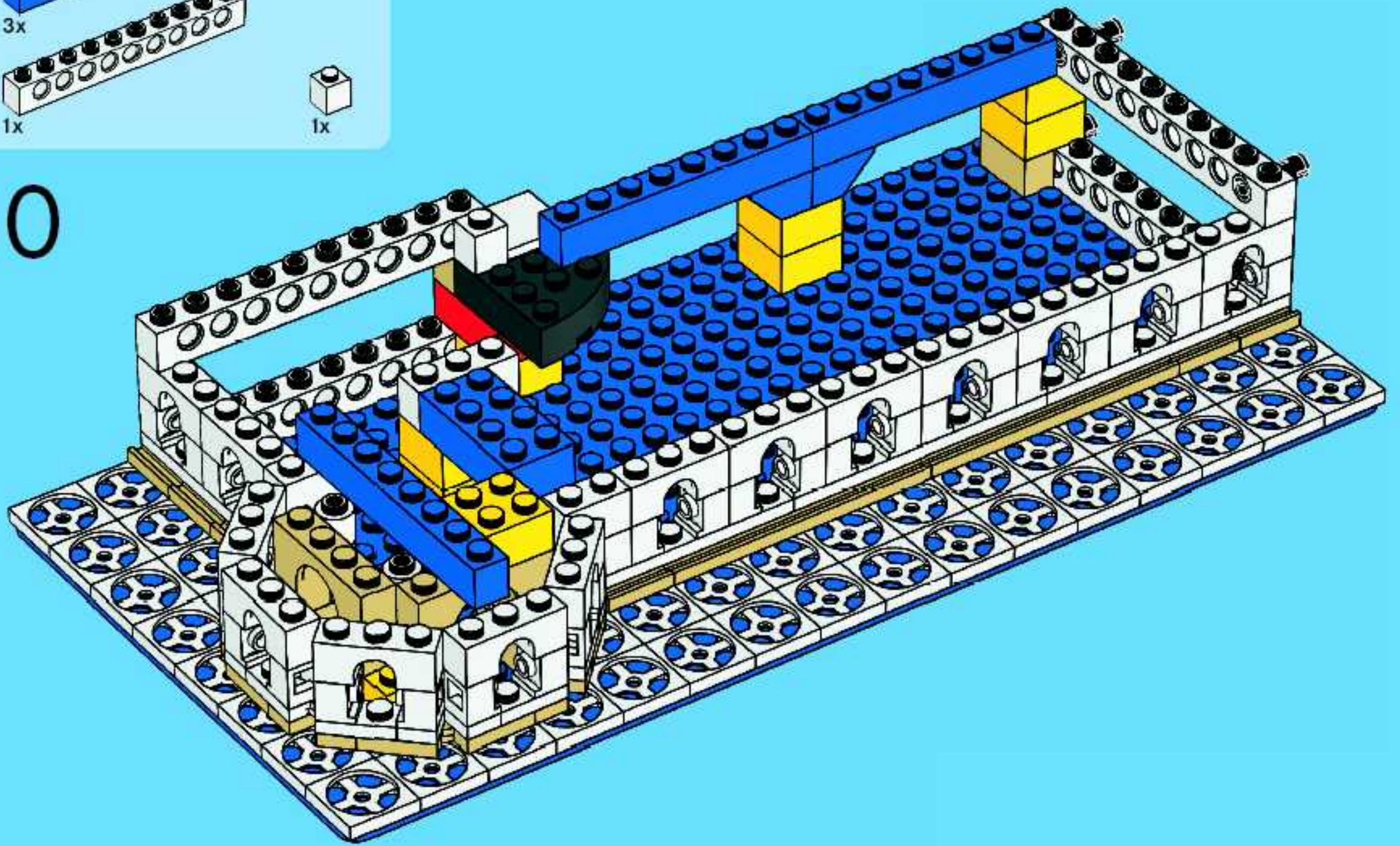

11

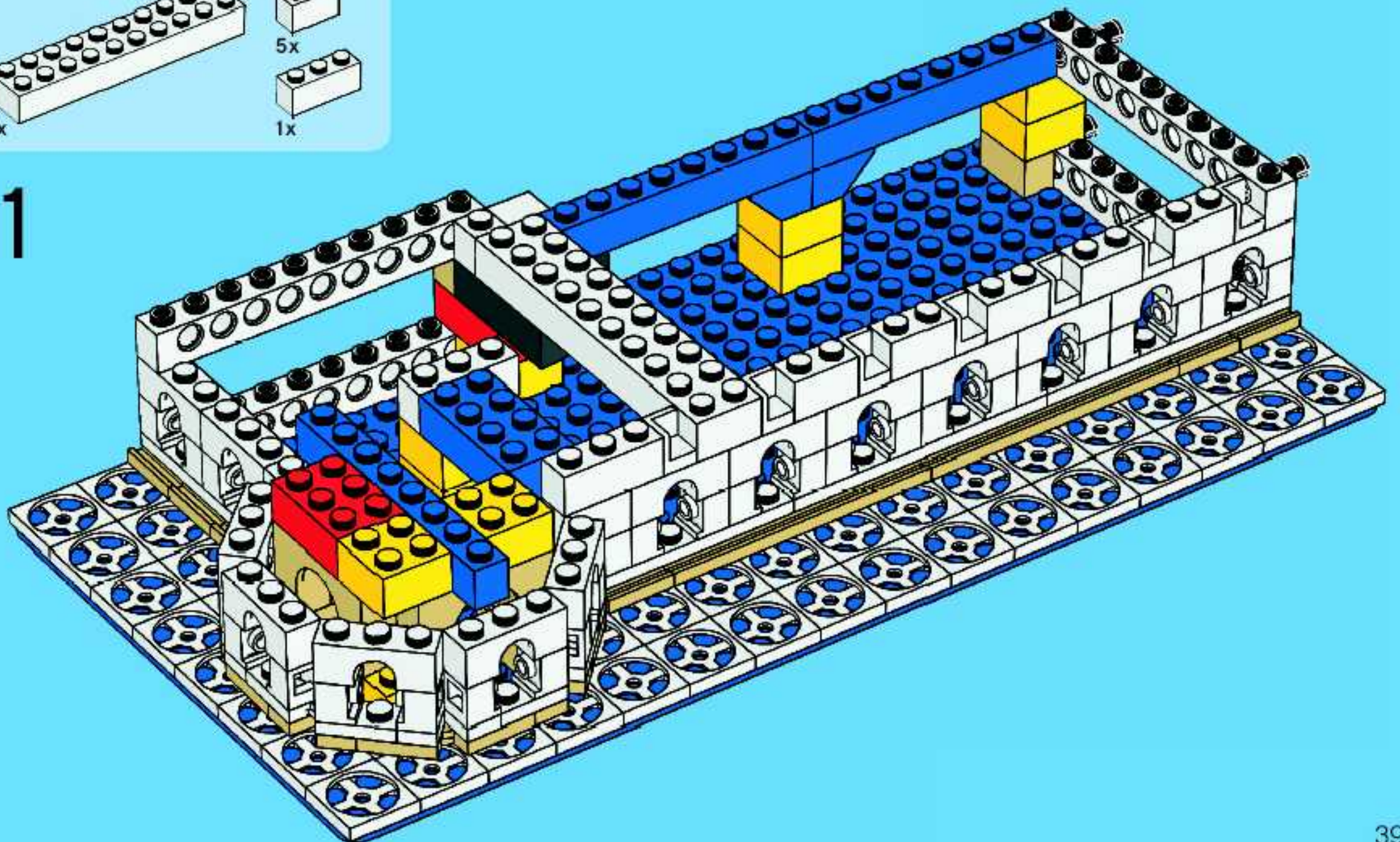



7x



10x



2x

# 12

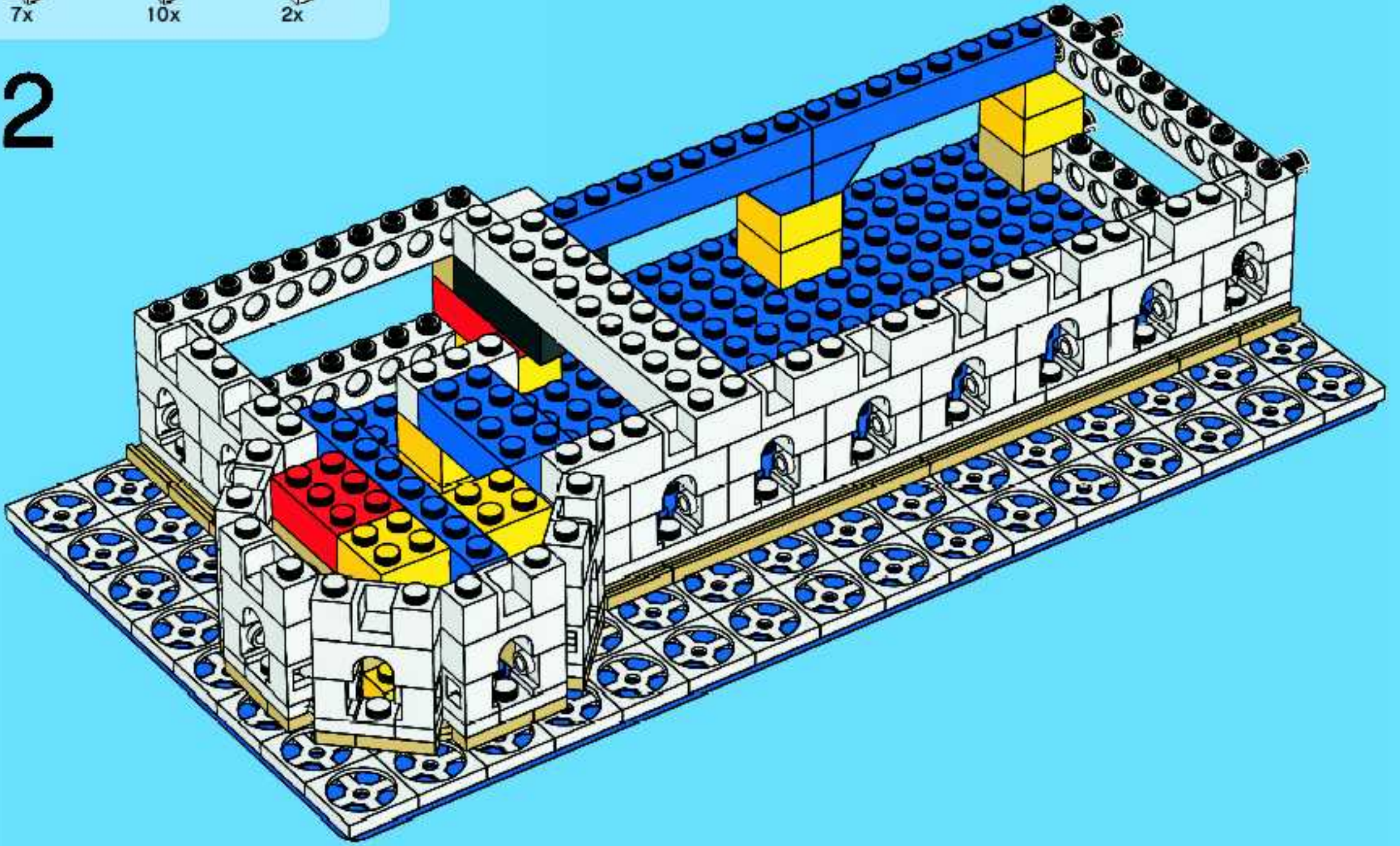

1x

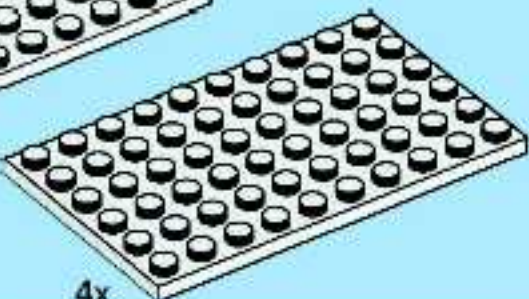

4x



2x

# 13

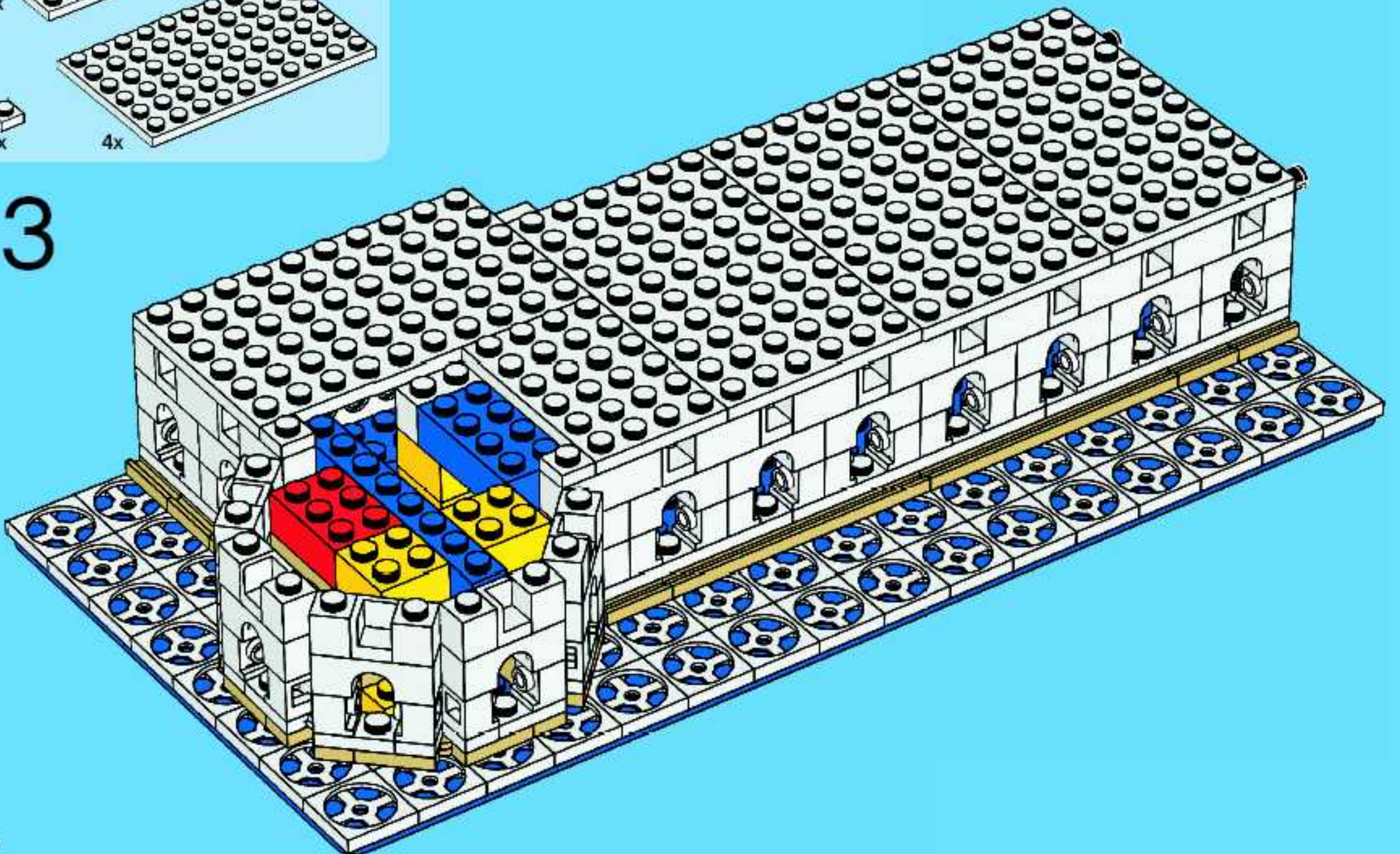



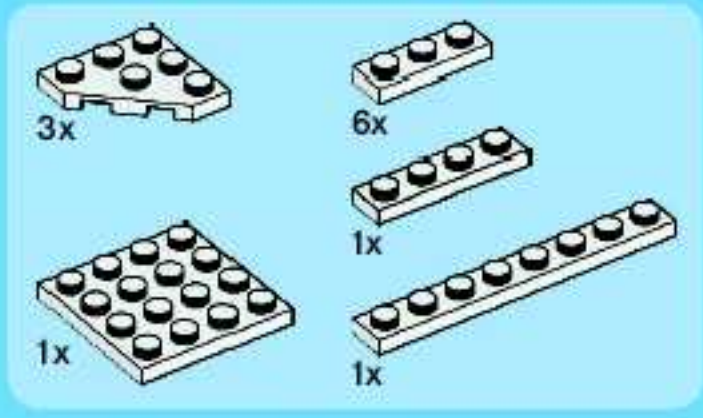

14

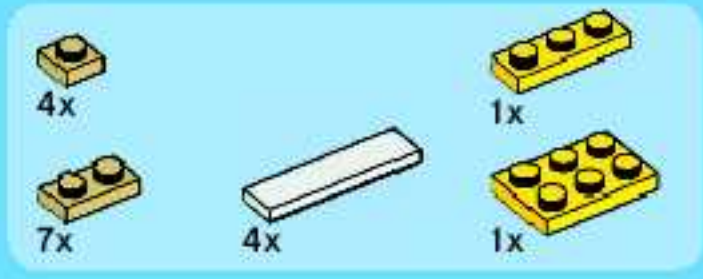
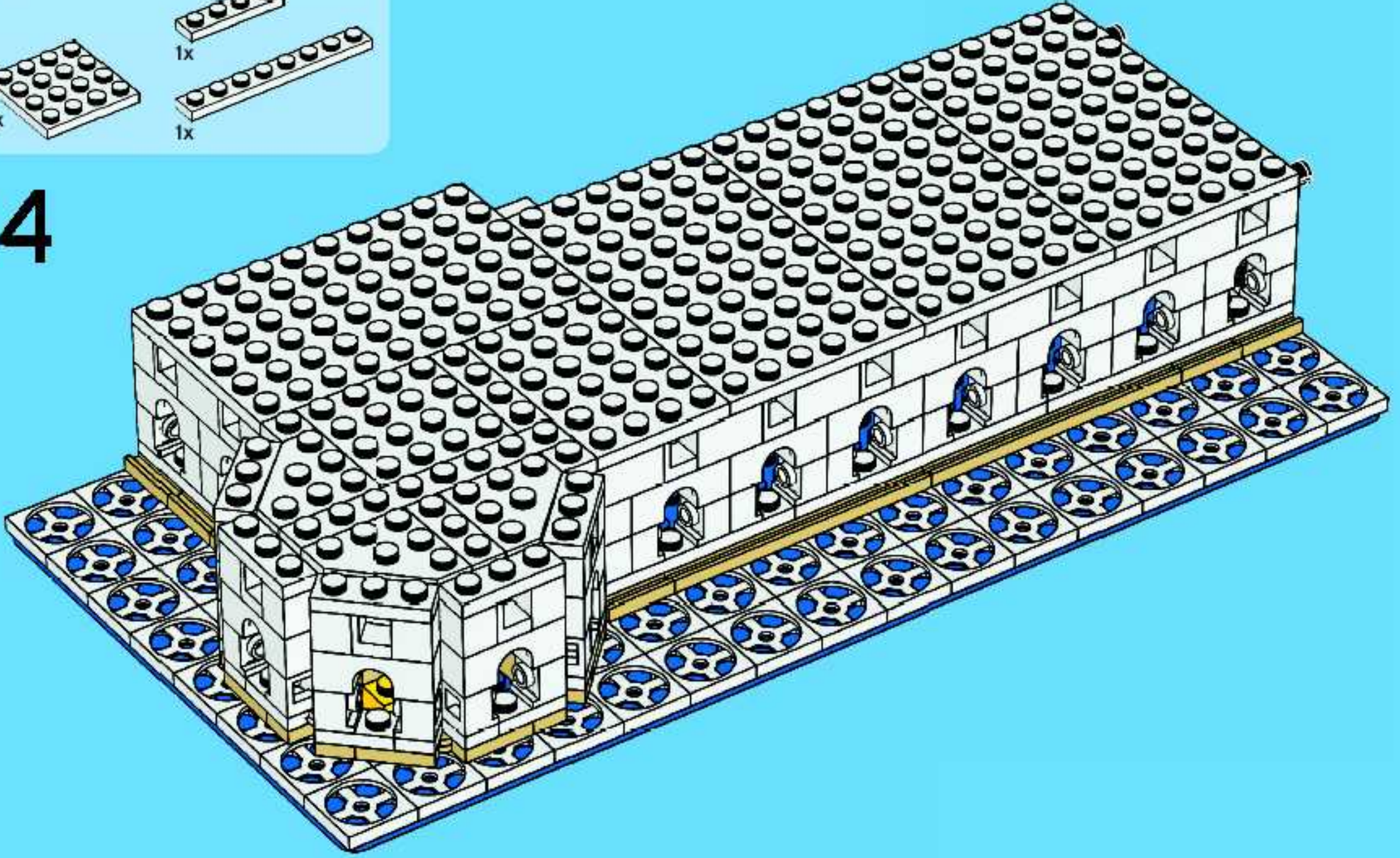

15

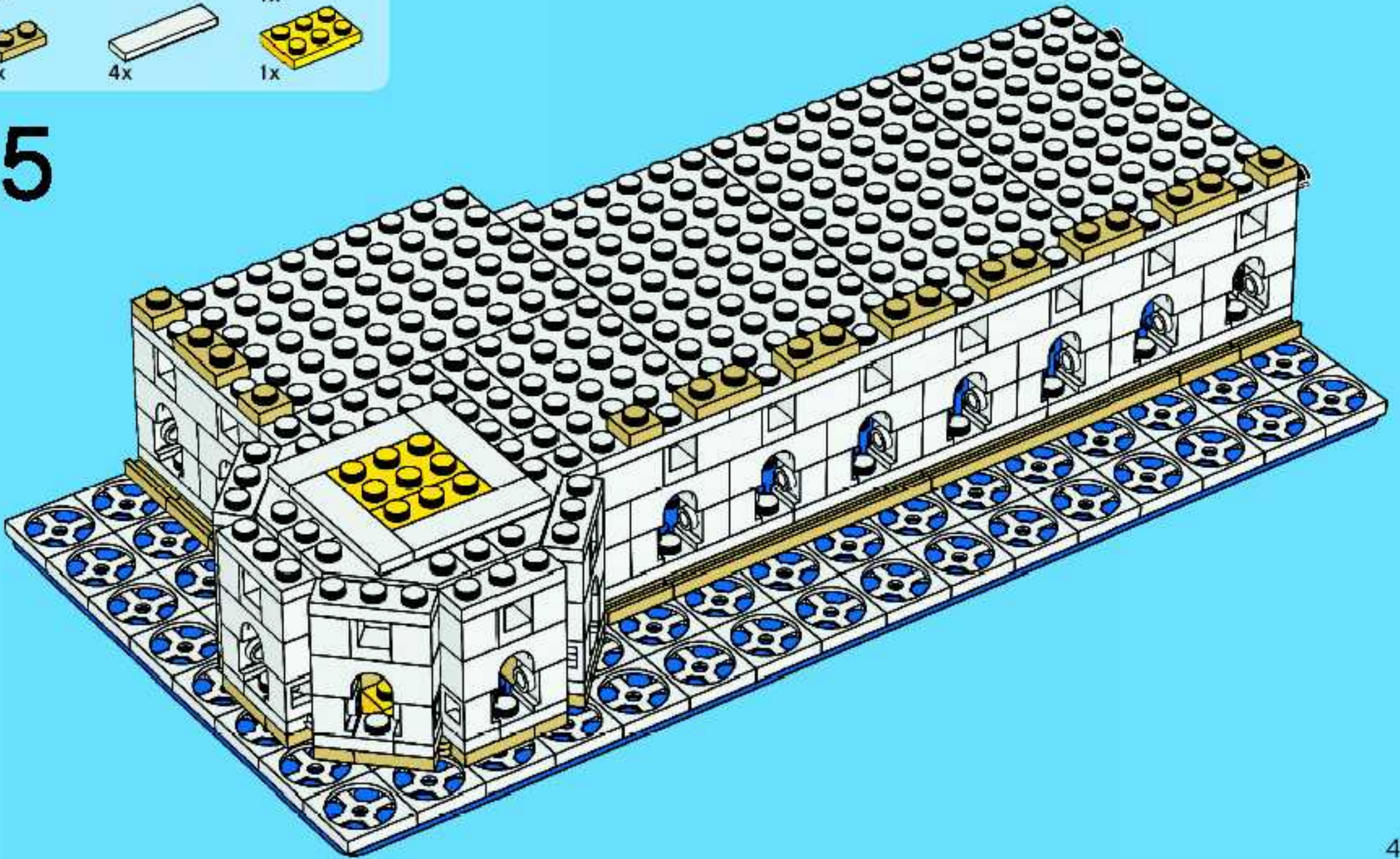



5x



1x



3x

# 16

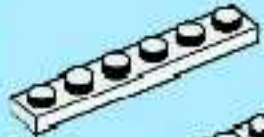
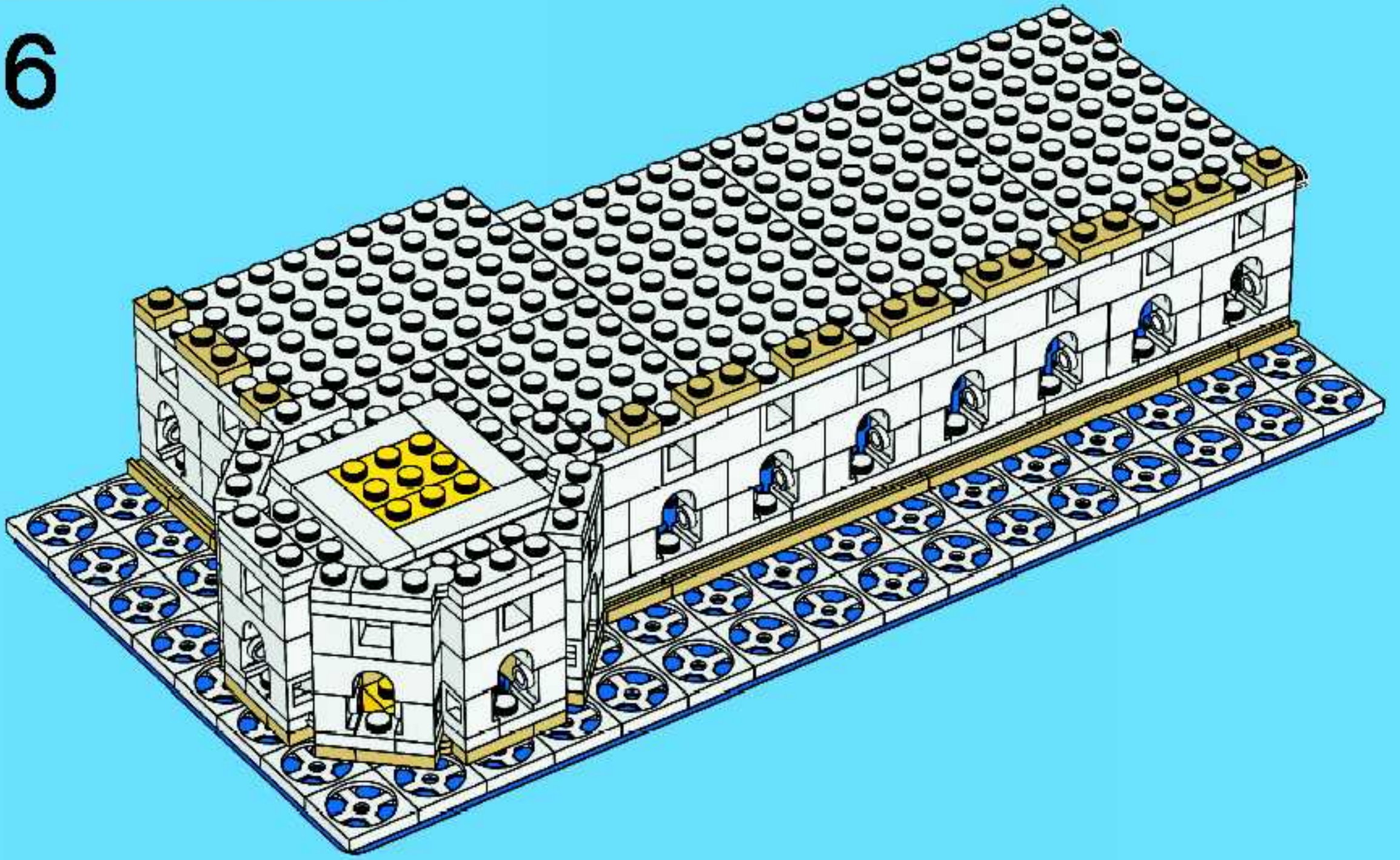

2x



3x

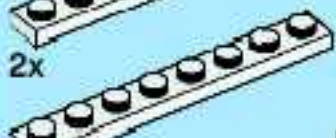

2x



5x



1x

# 17

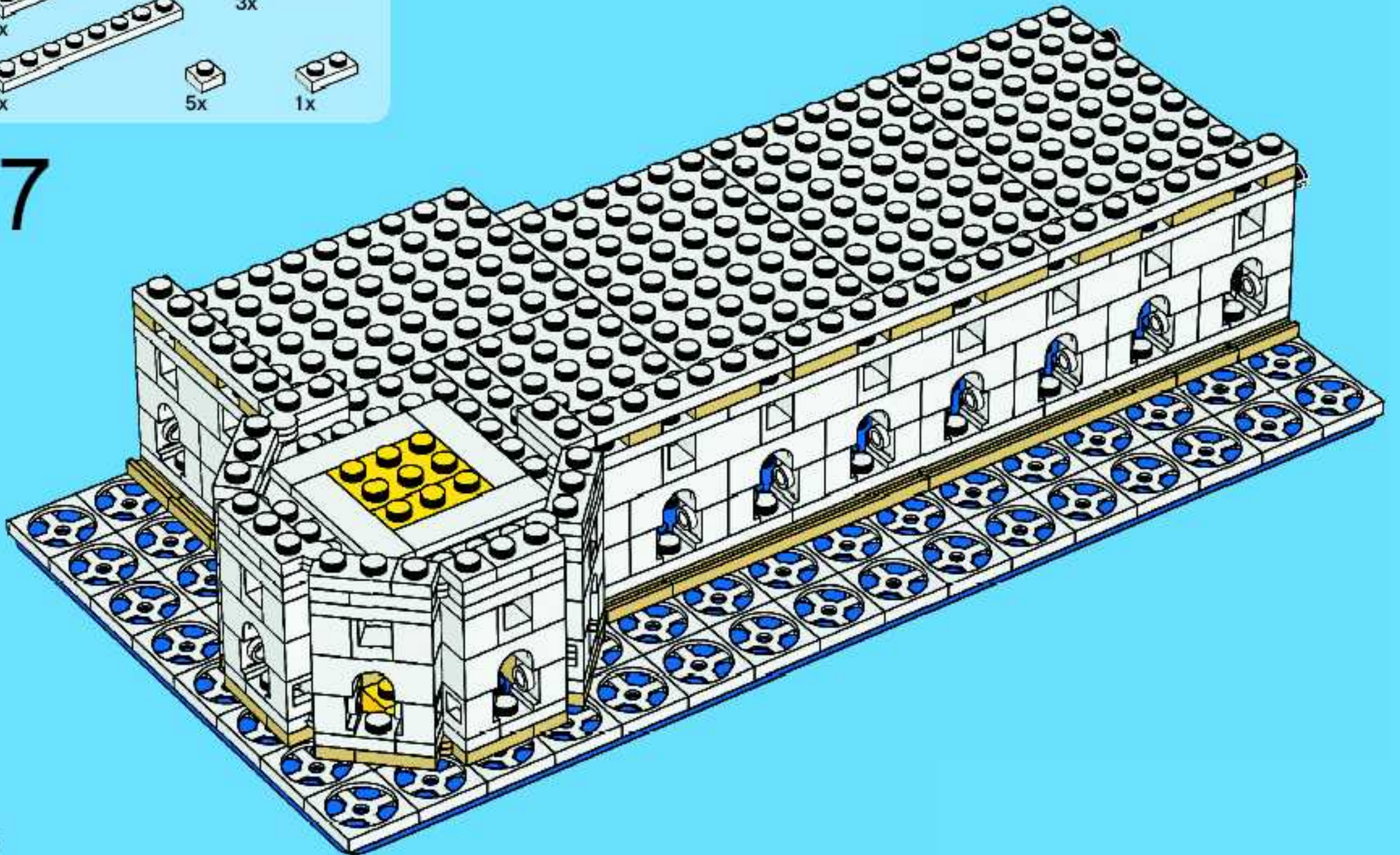

30x

18

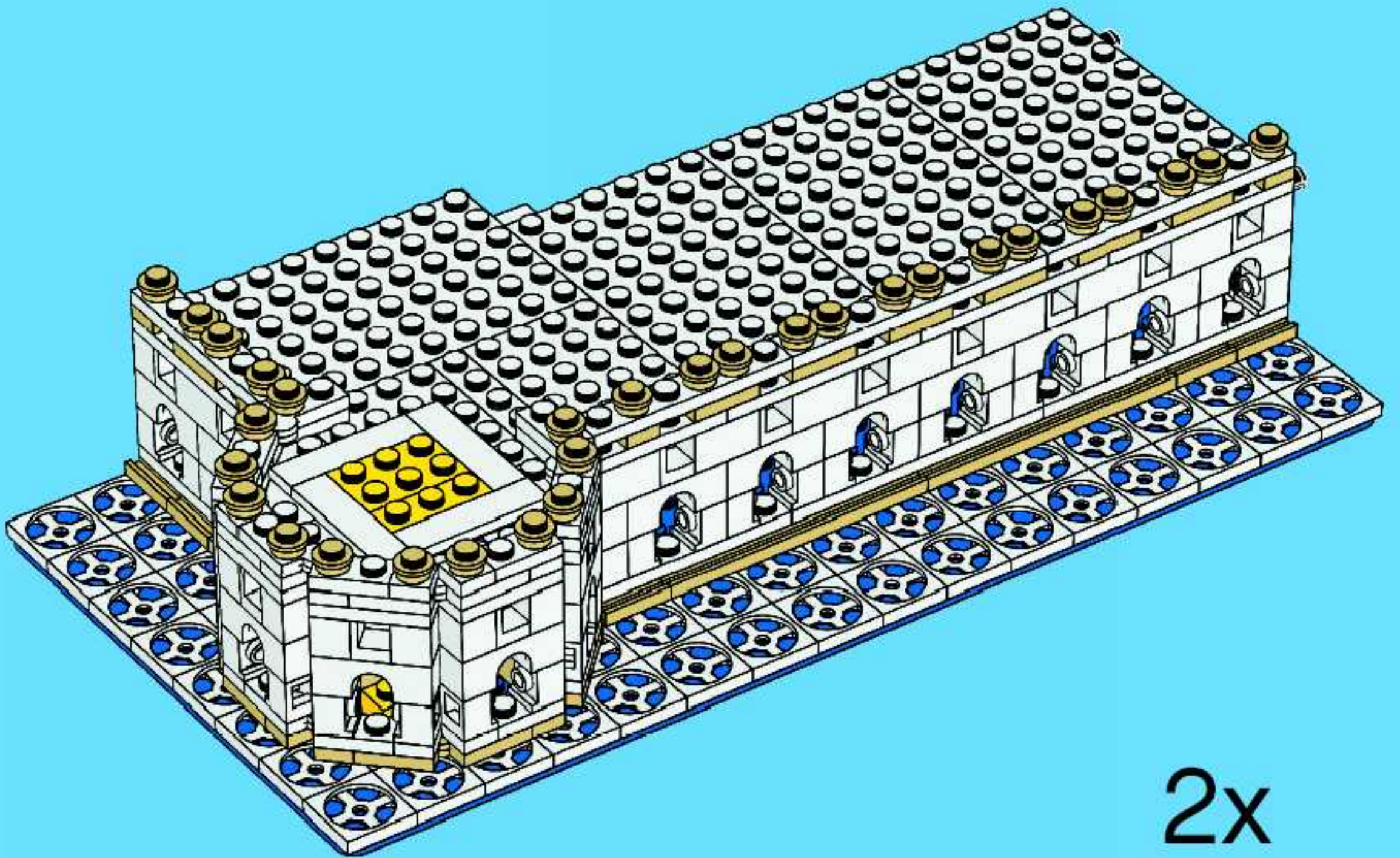

2x

19

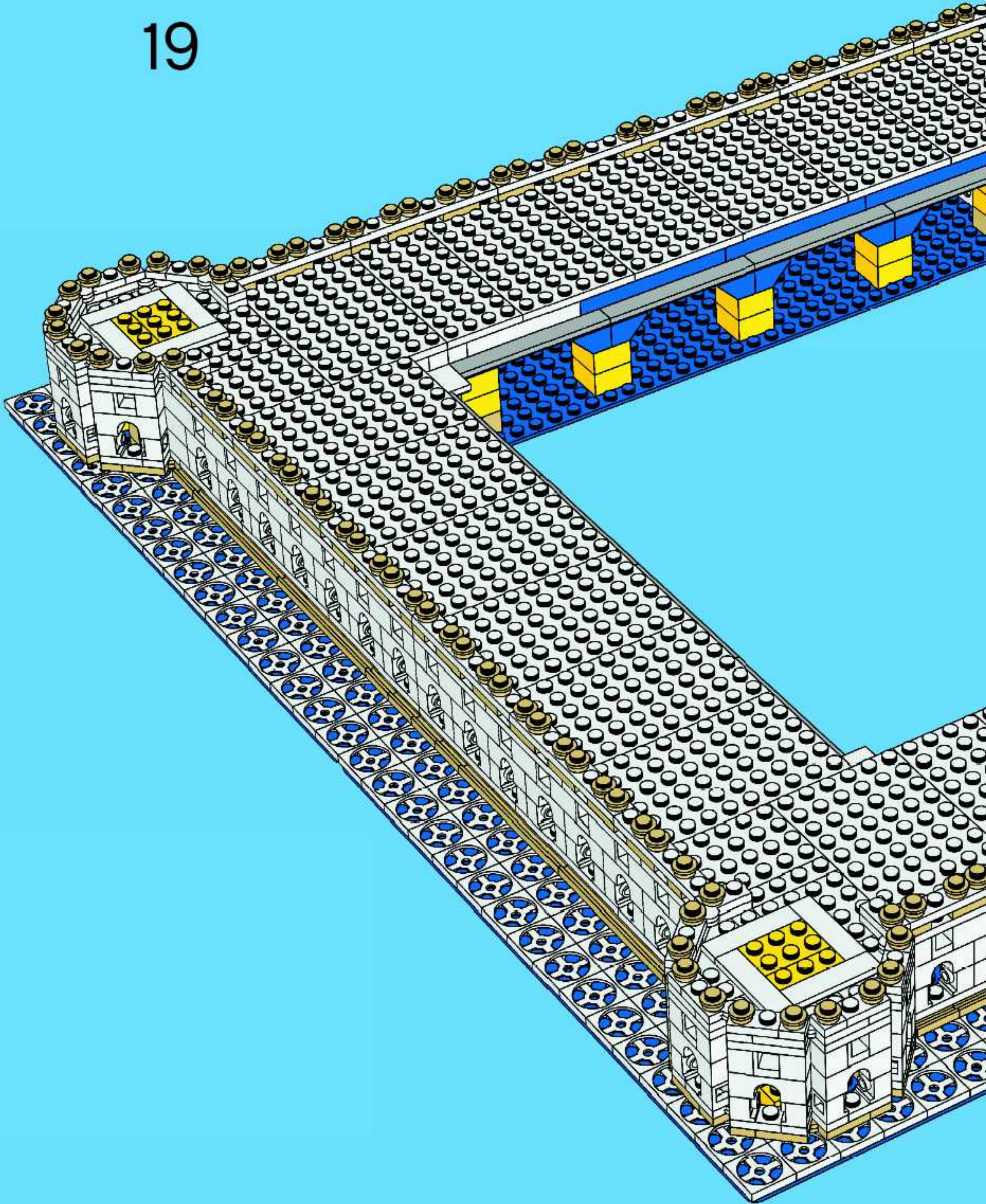

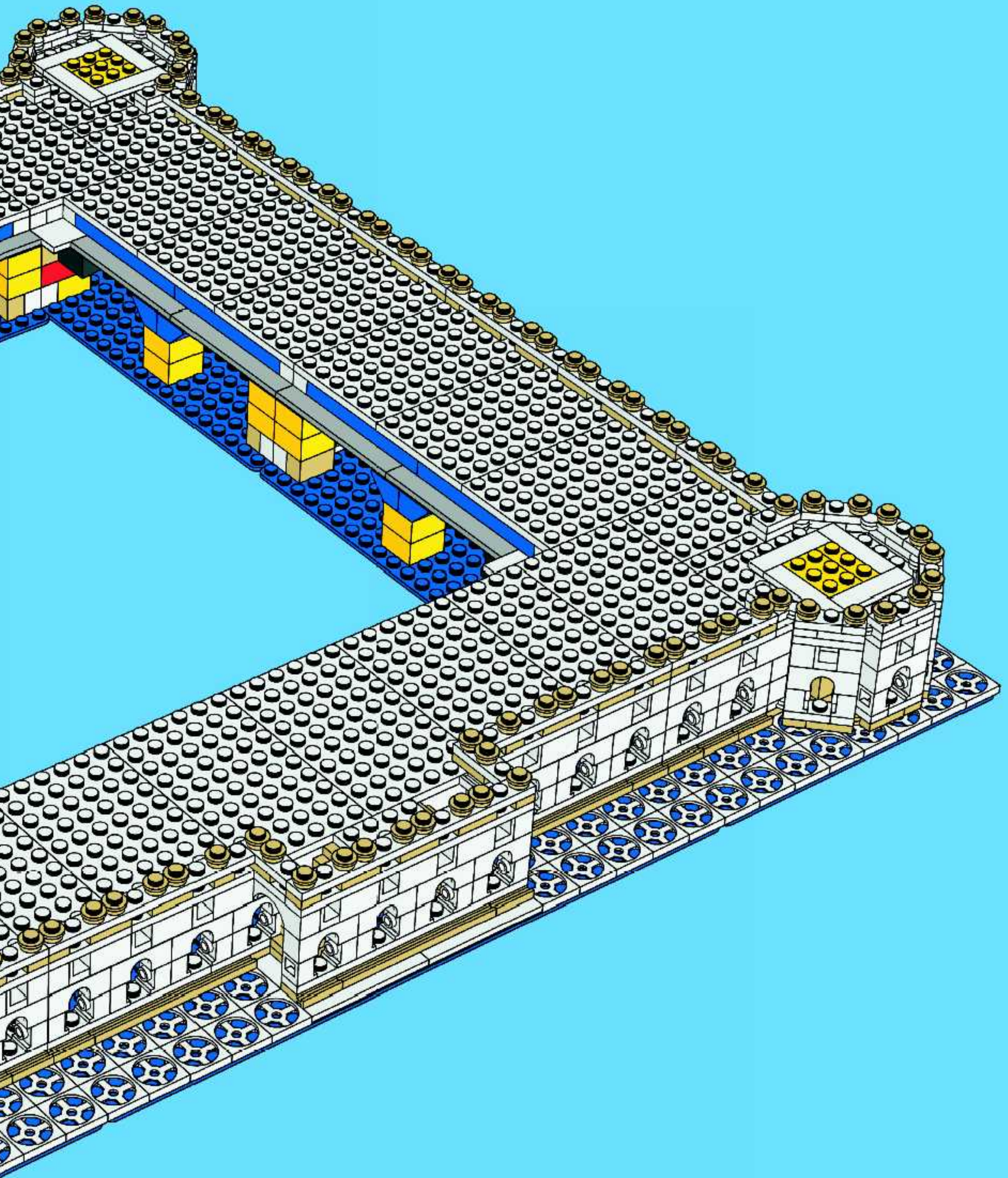

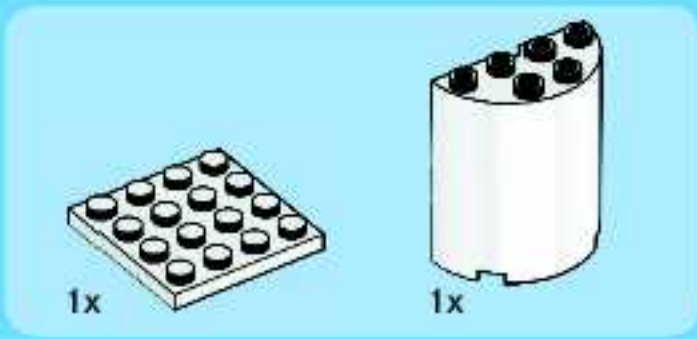
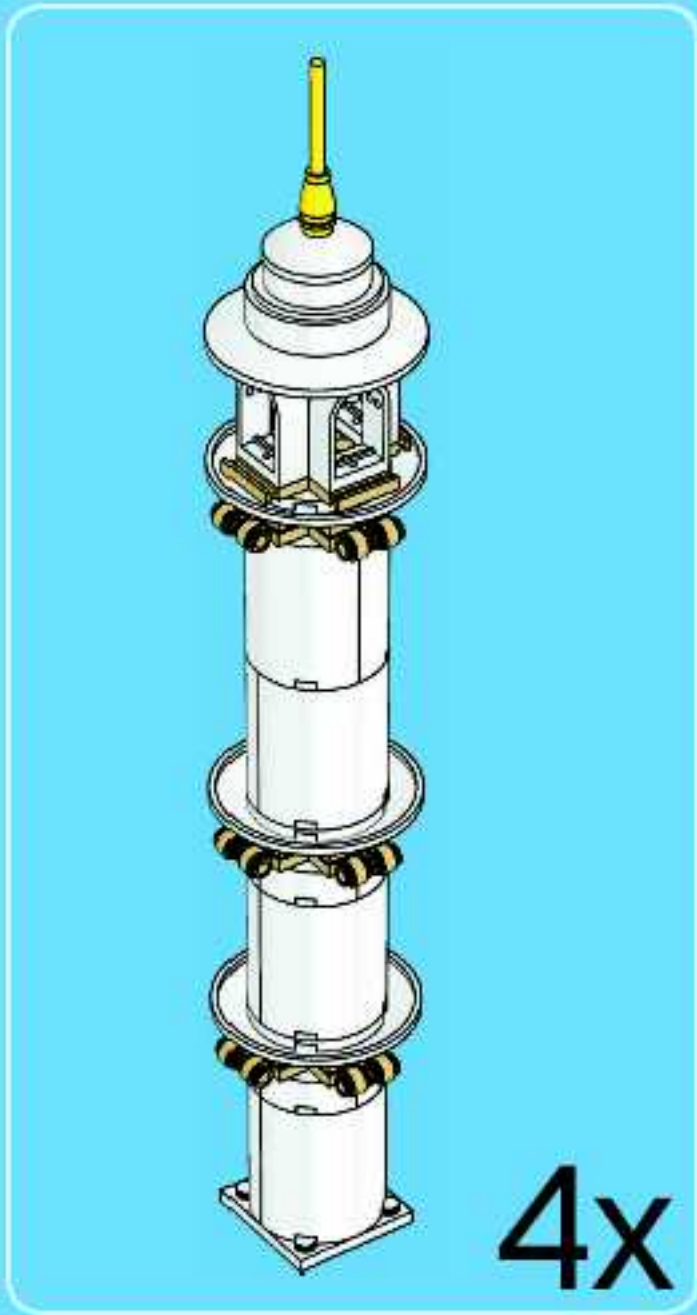

1

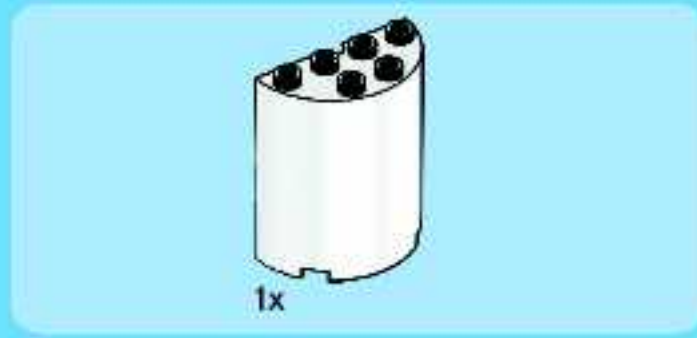

2



3

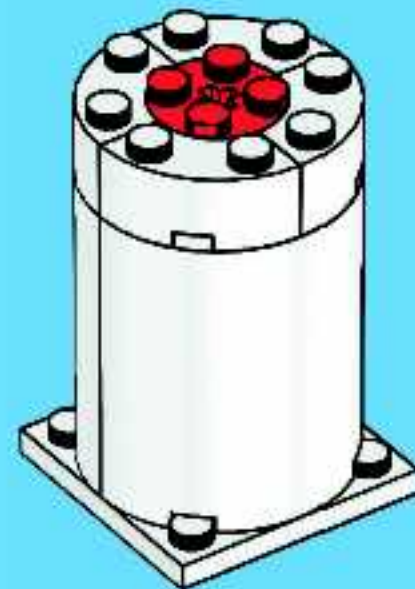



8x

4



1x



1x

6

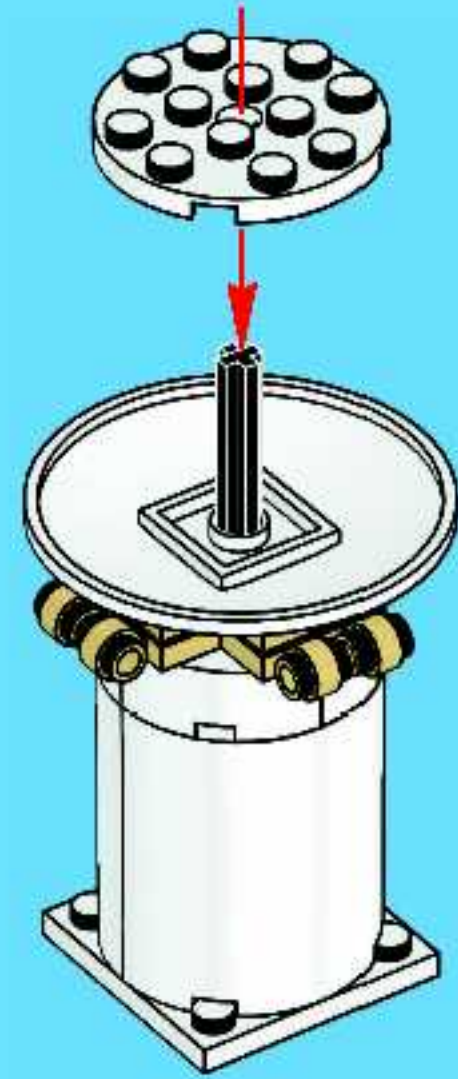

10

1x



4x

5

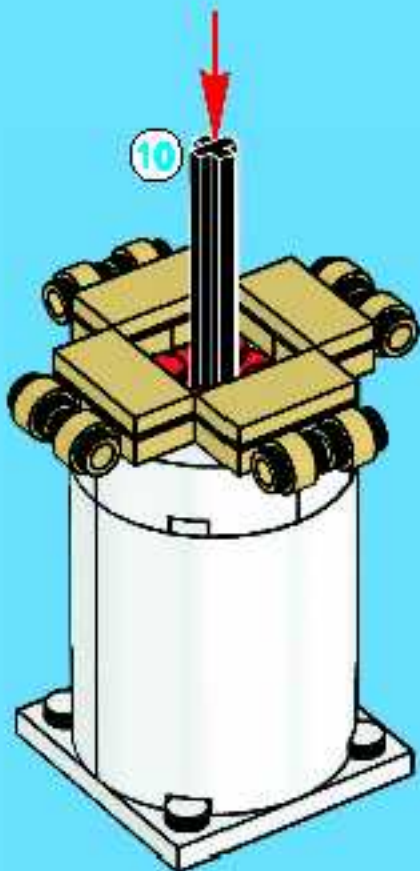

10

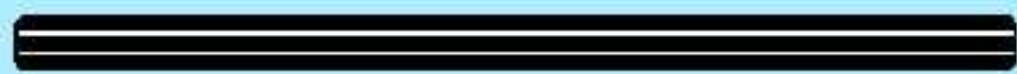

10

1:1

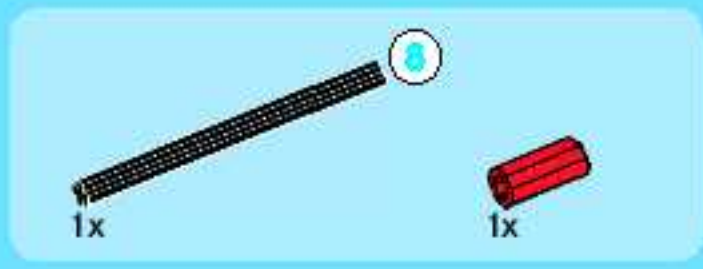

7

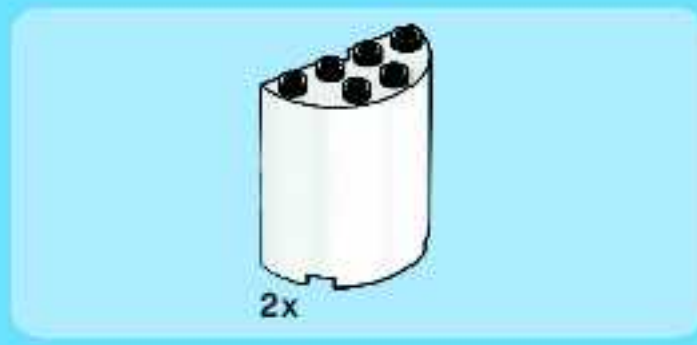

8

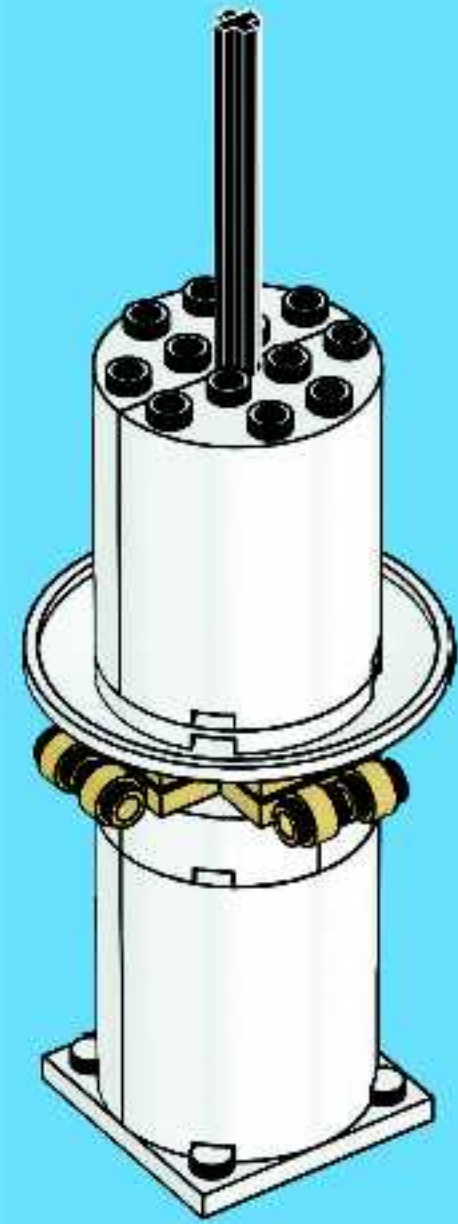





1x



4x

9

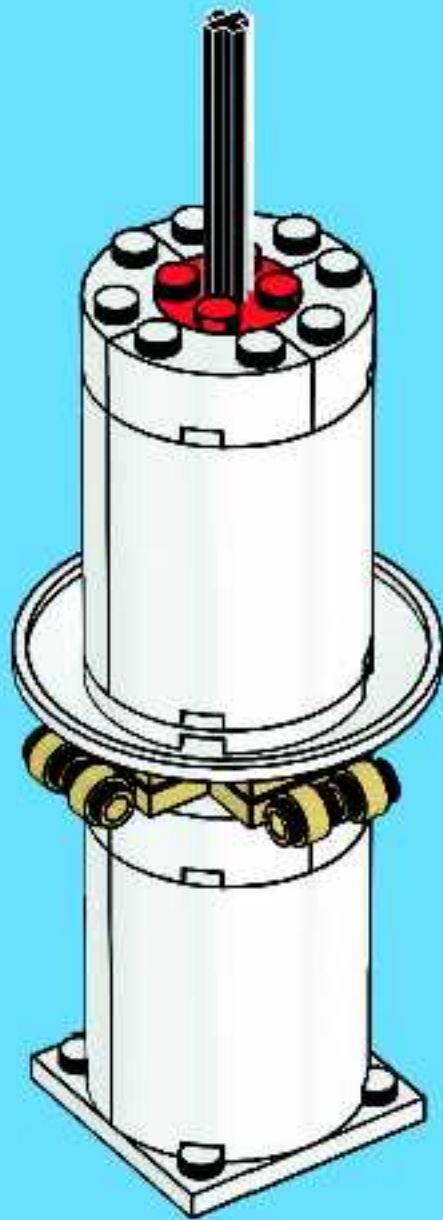

8x

10

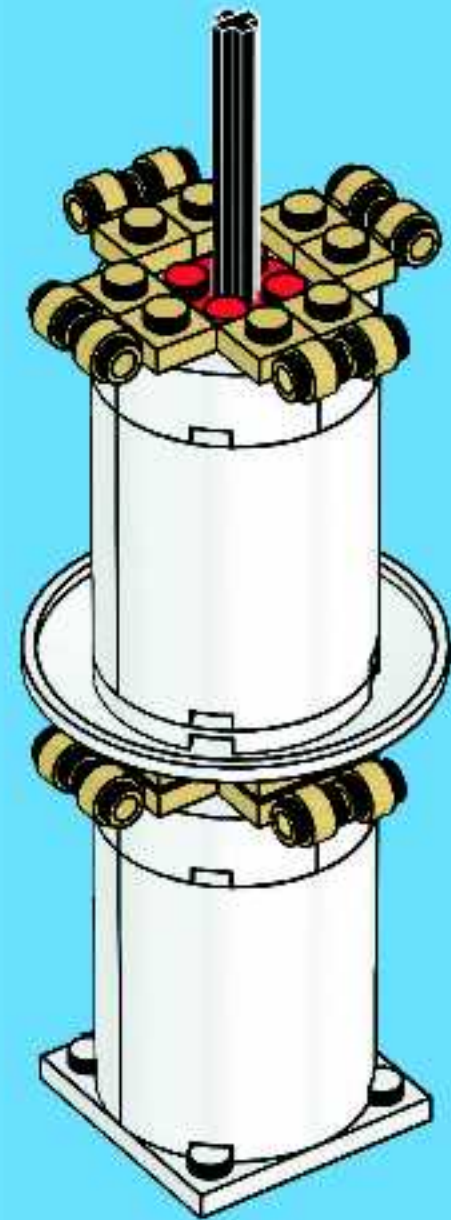



4x

# 11

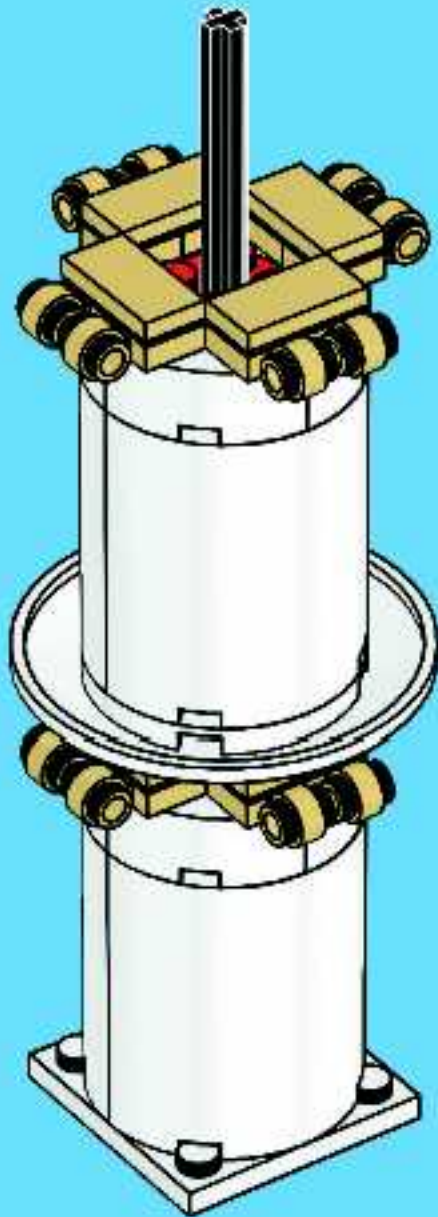

1x



1x

# 12

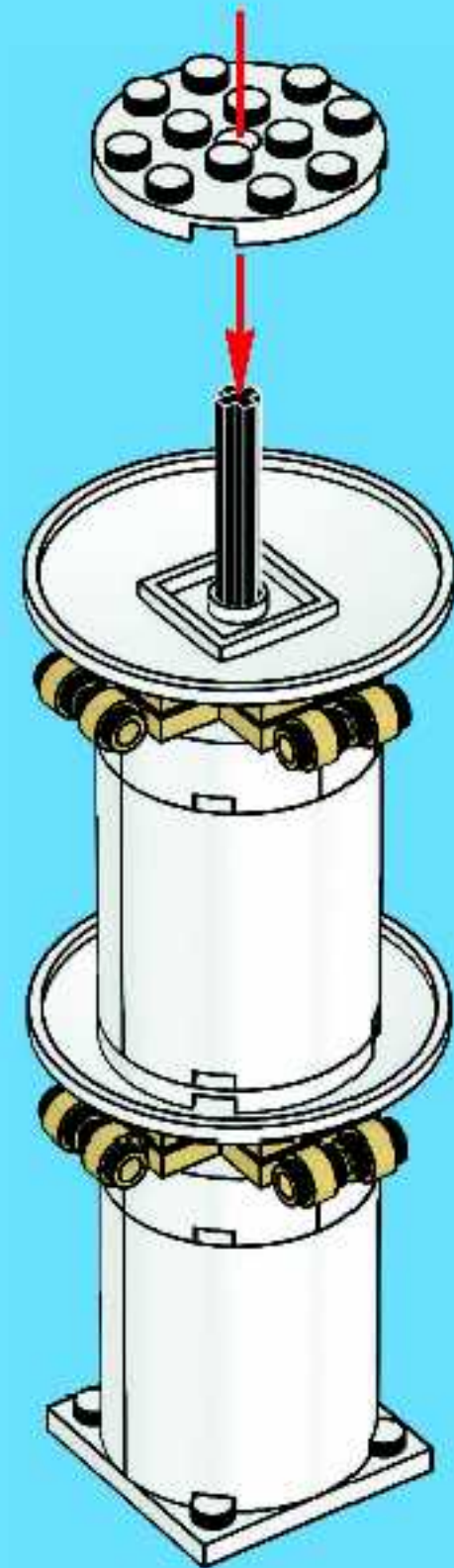



13

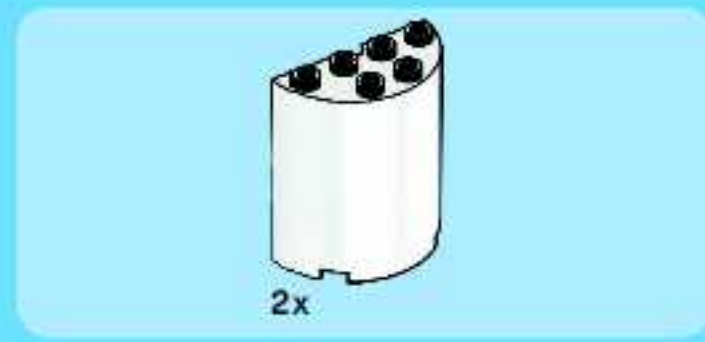

14

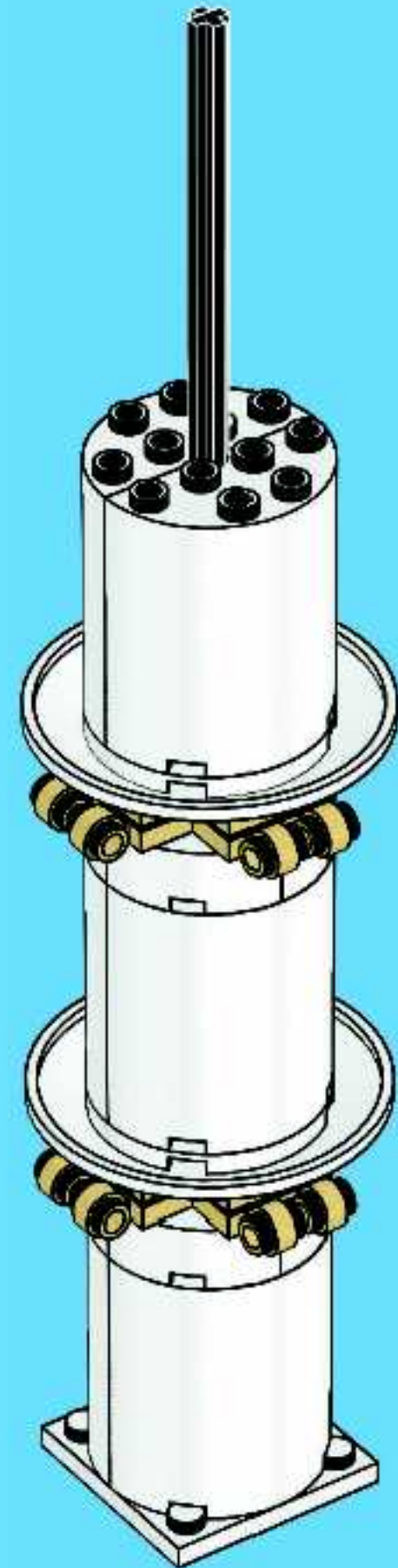

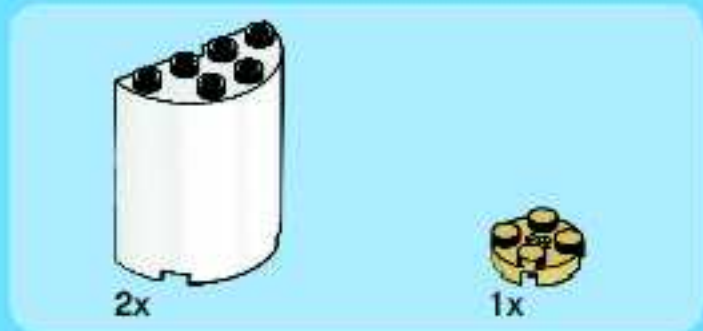

15

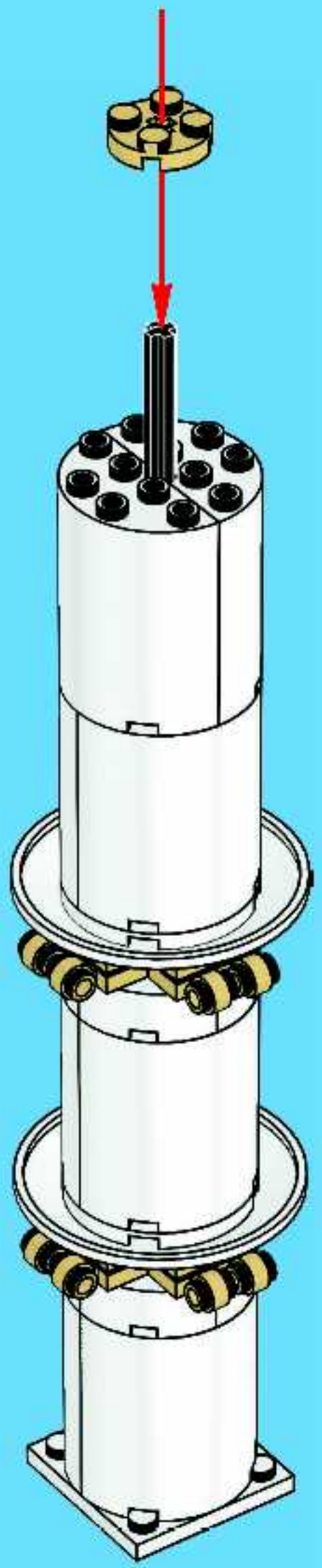

16

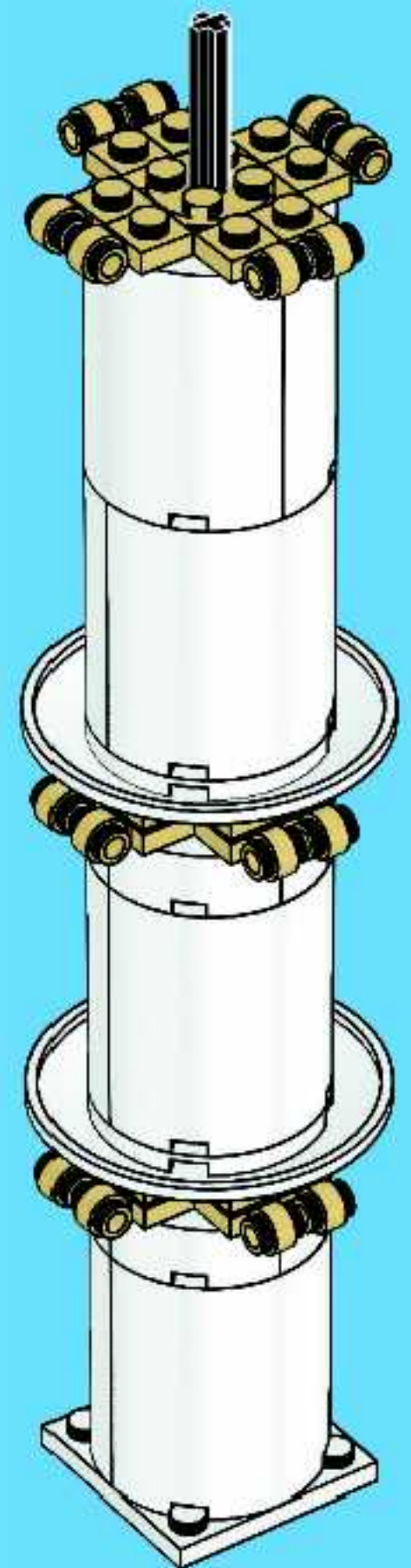



4x

17

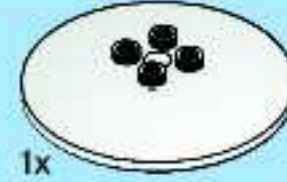
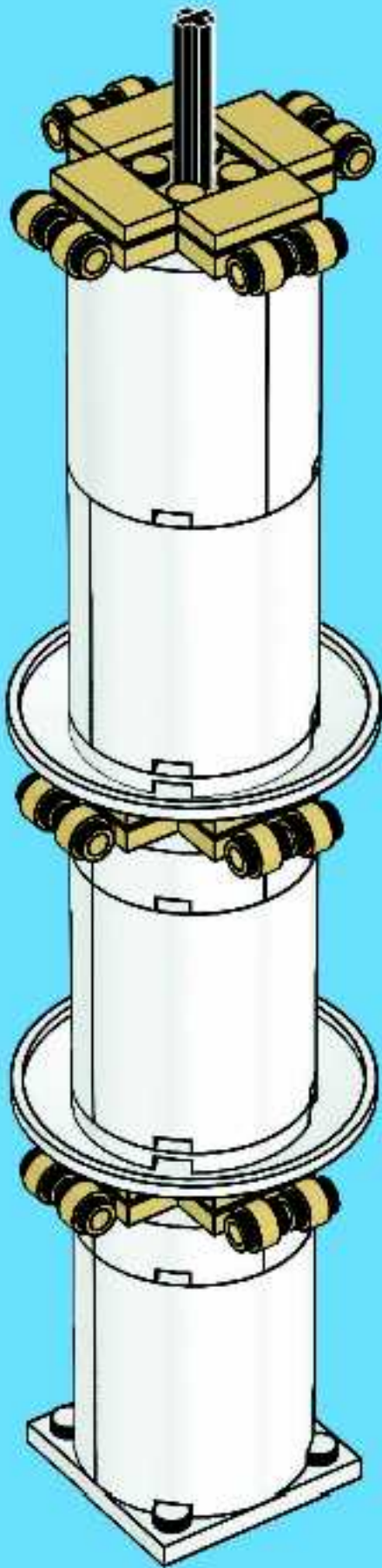

1x

18





19

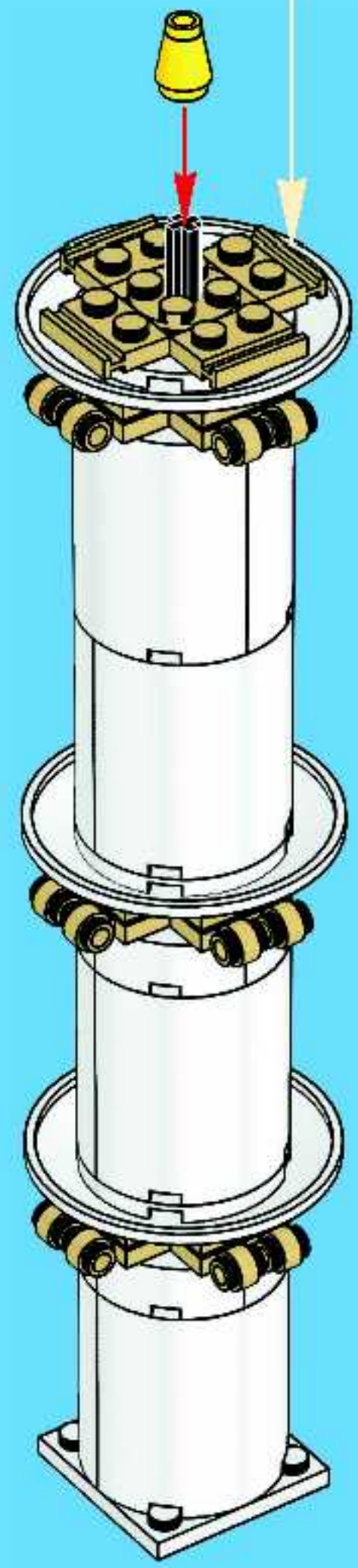
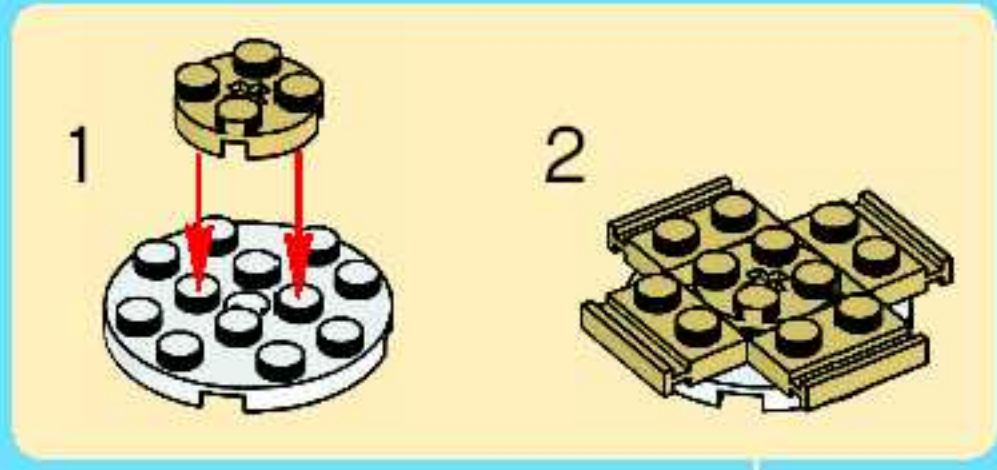



20

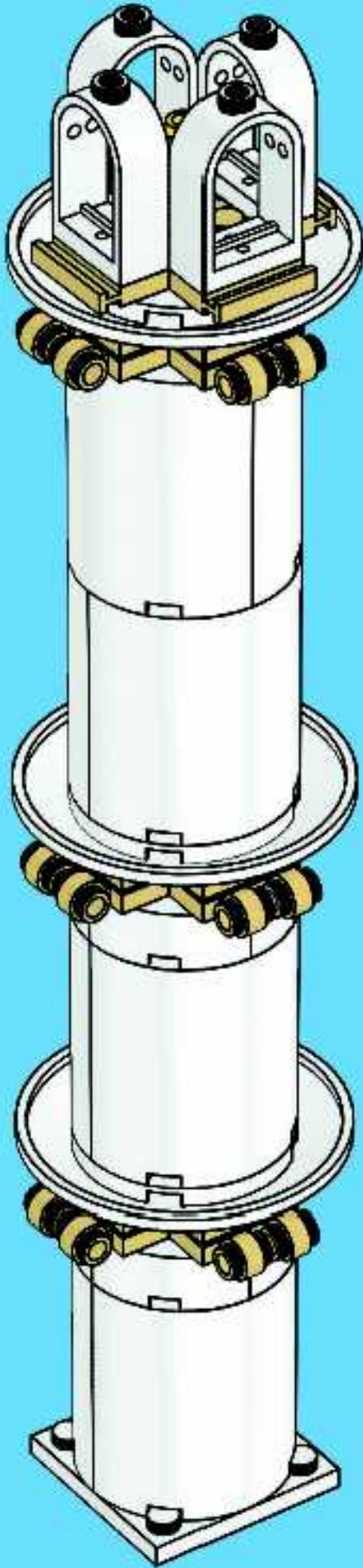

21

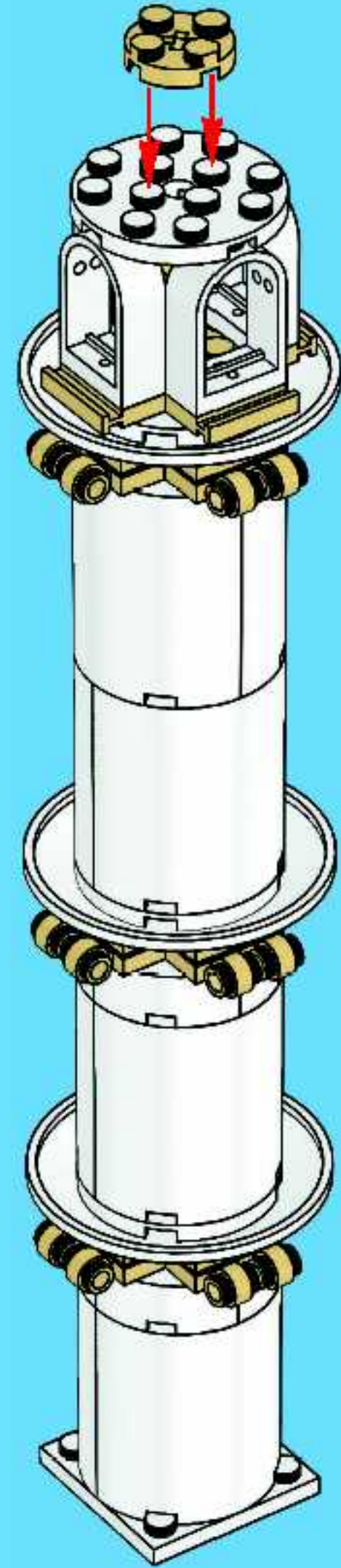



22

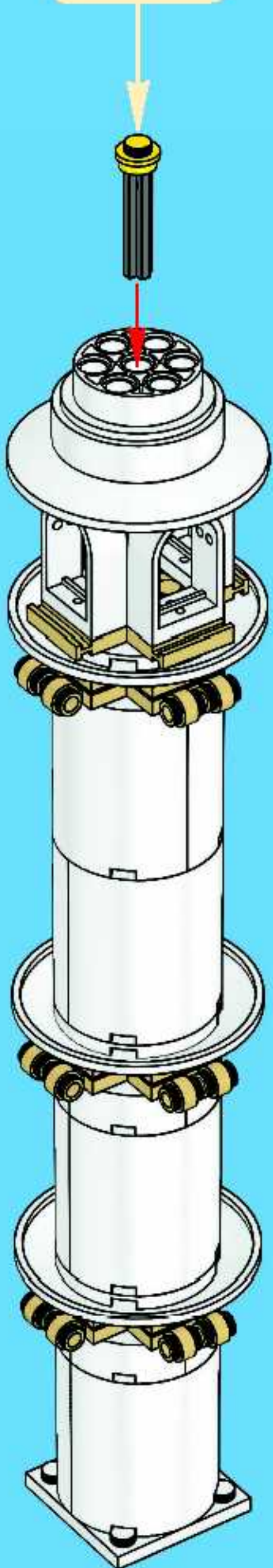
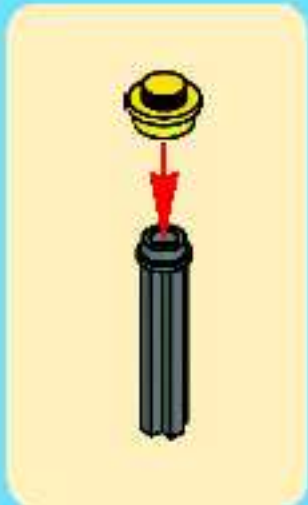



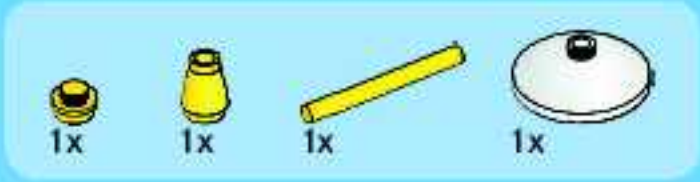

23

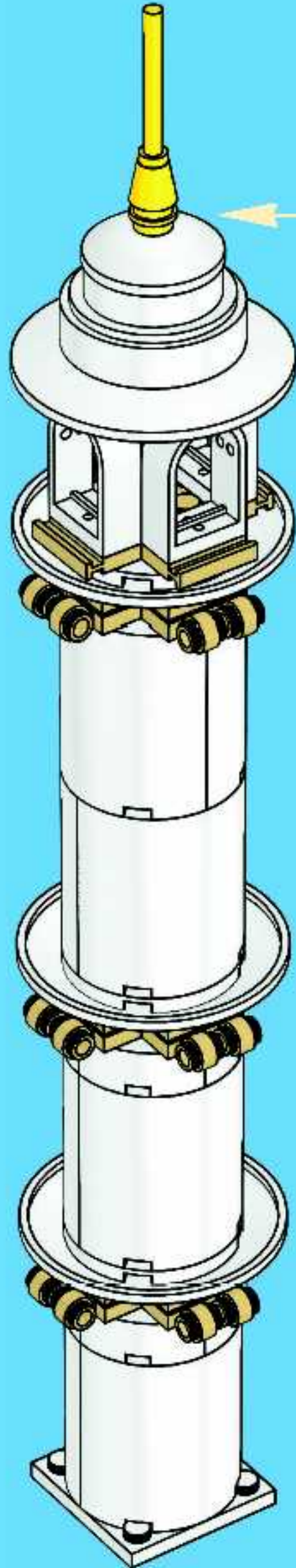
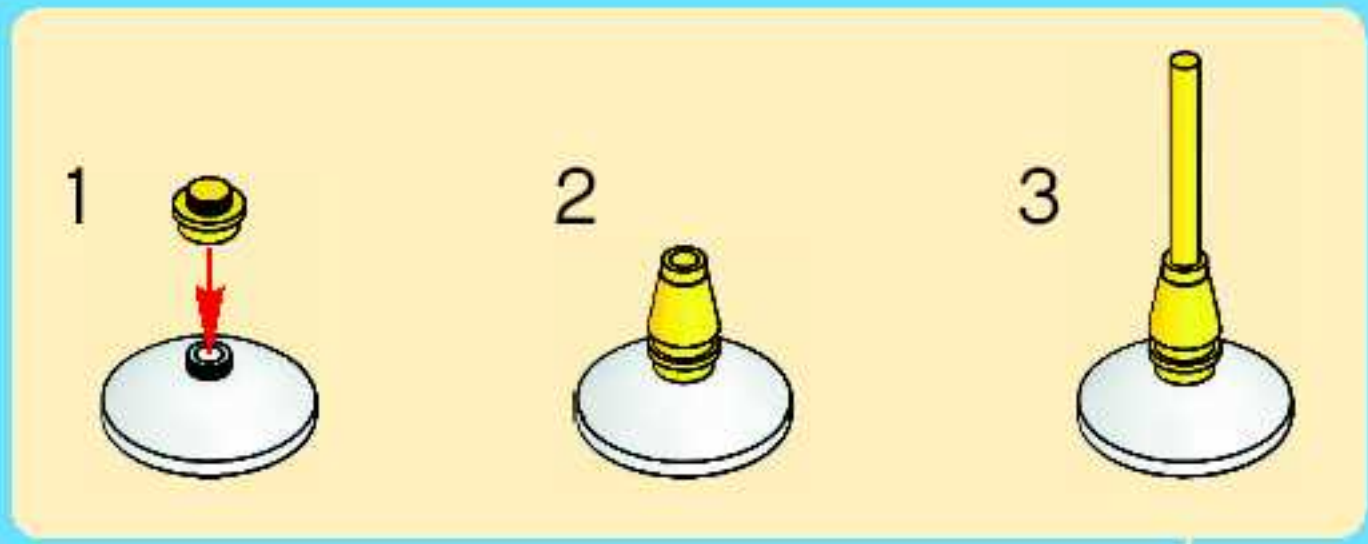

24

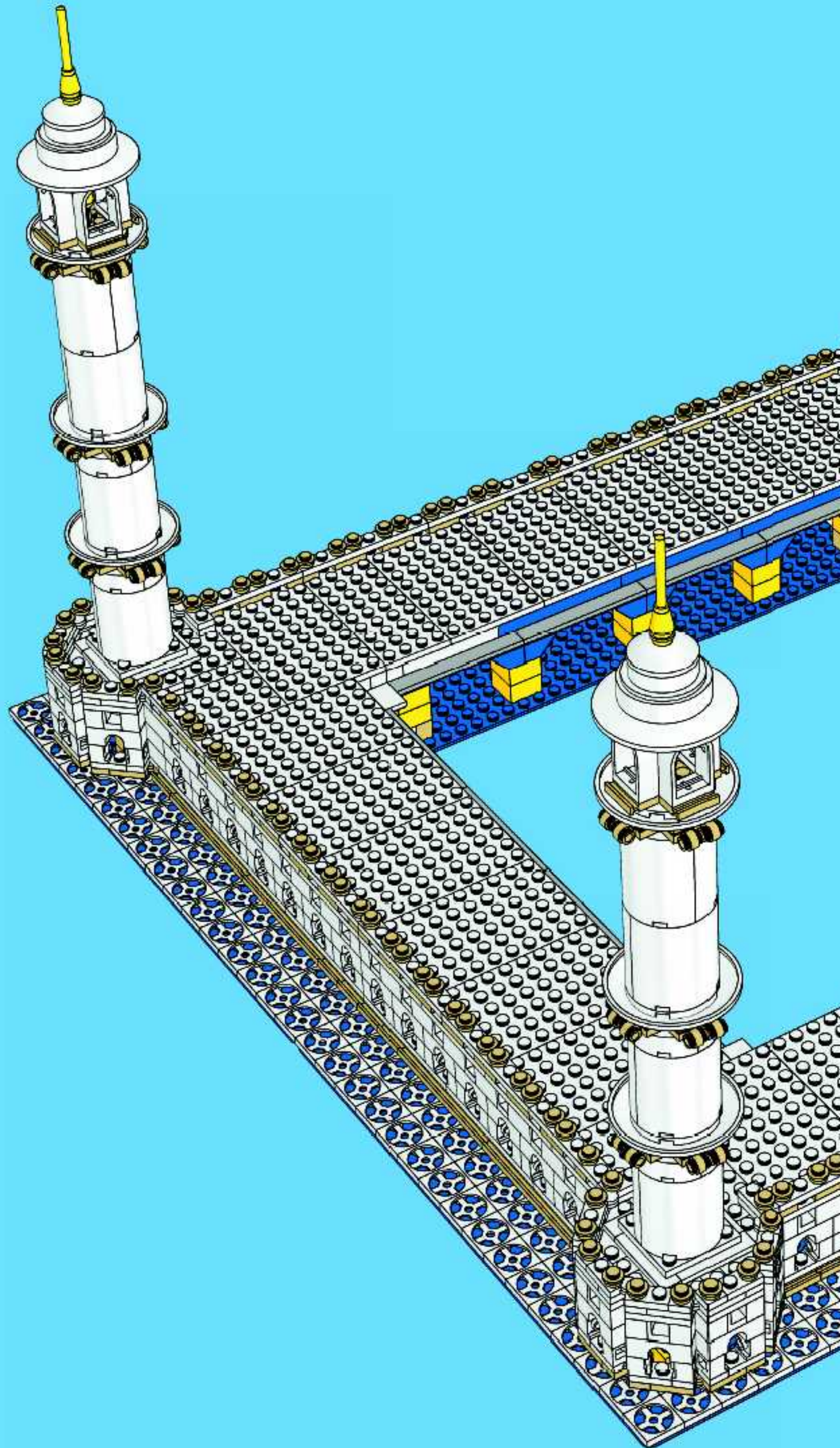



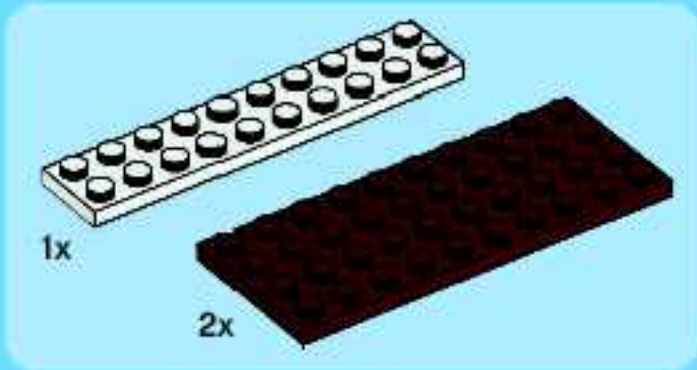
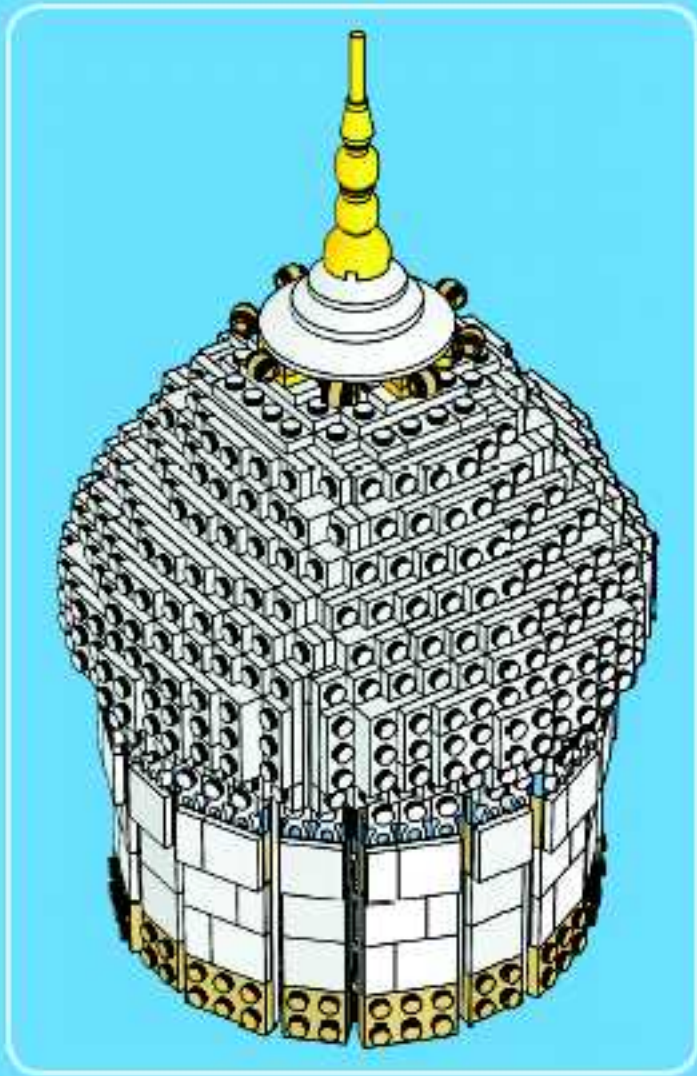

1

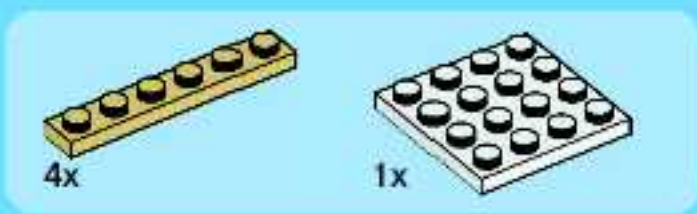
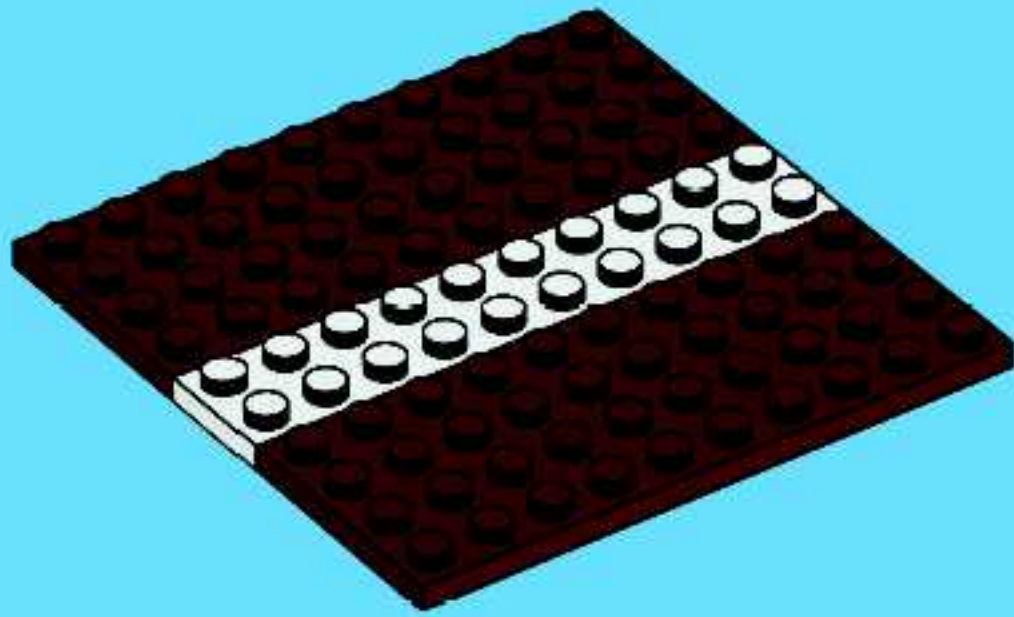

2

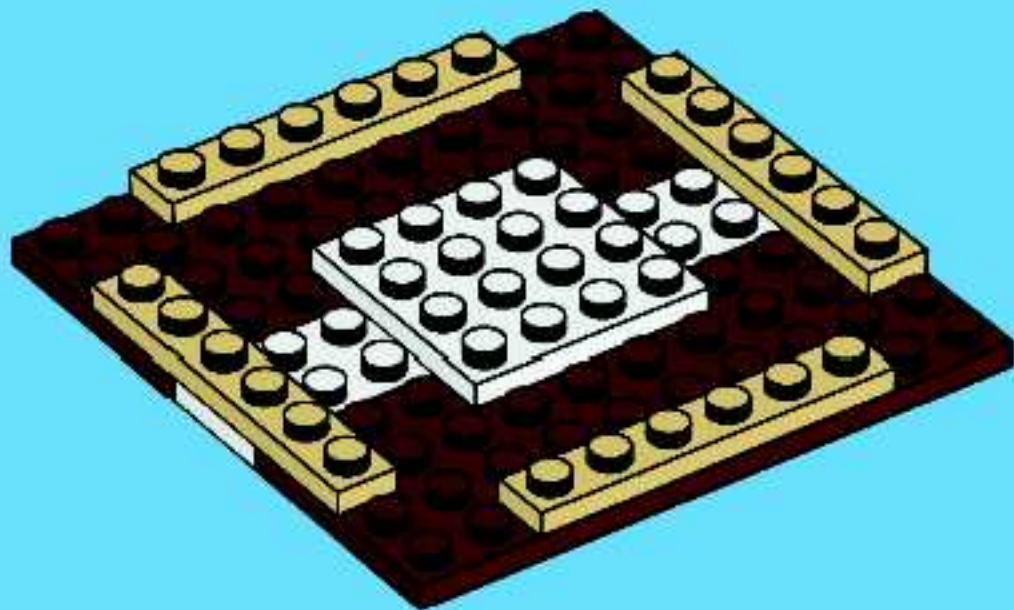



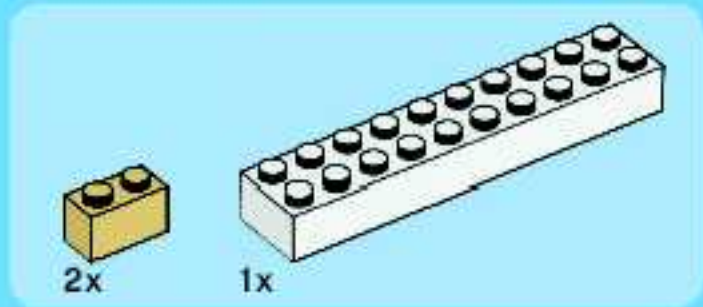

6

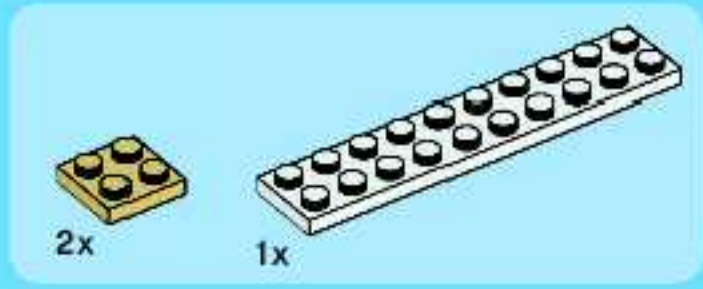
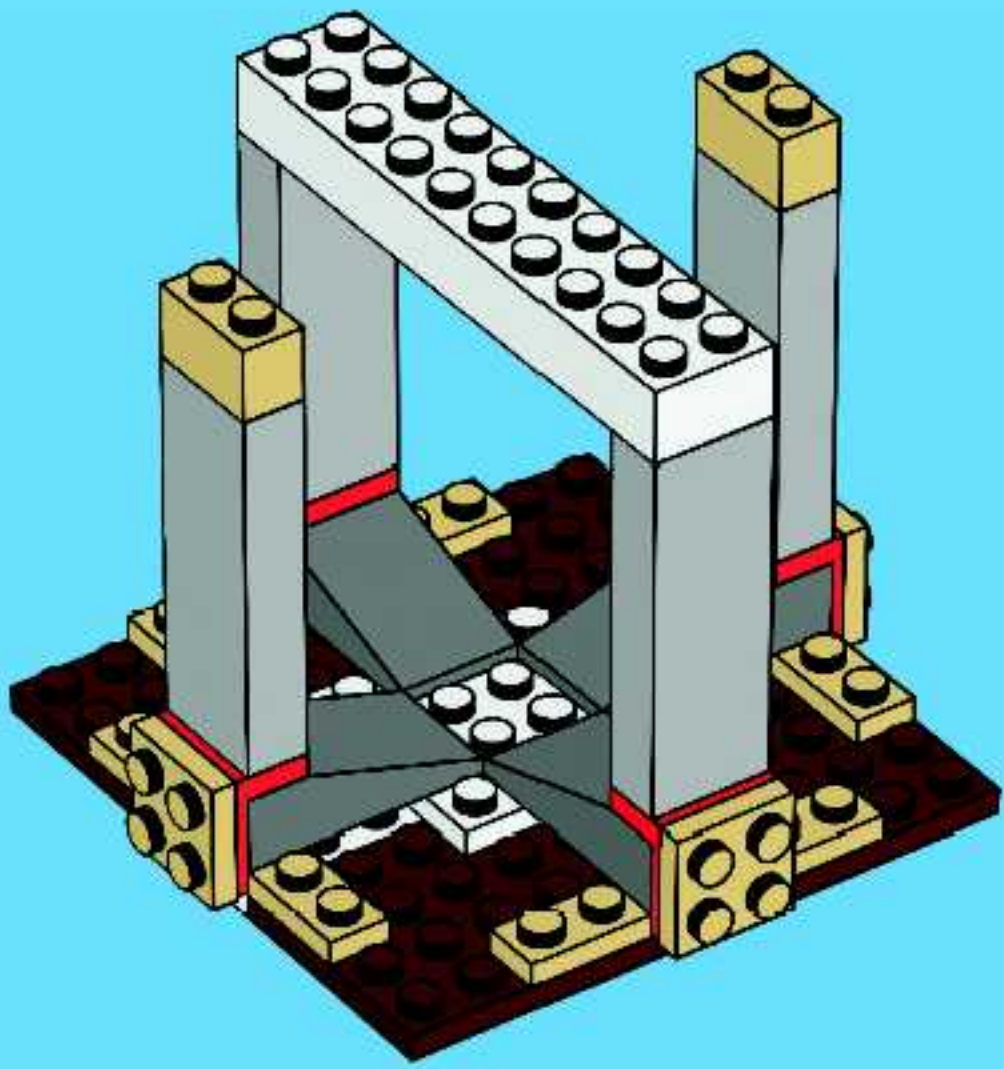

7

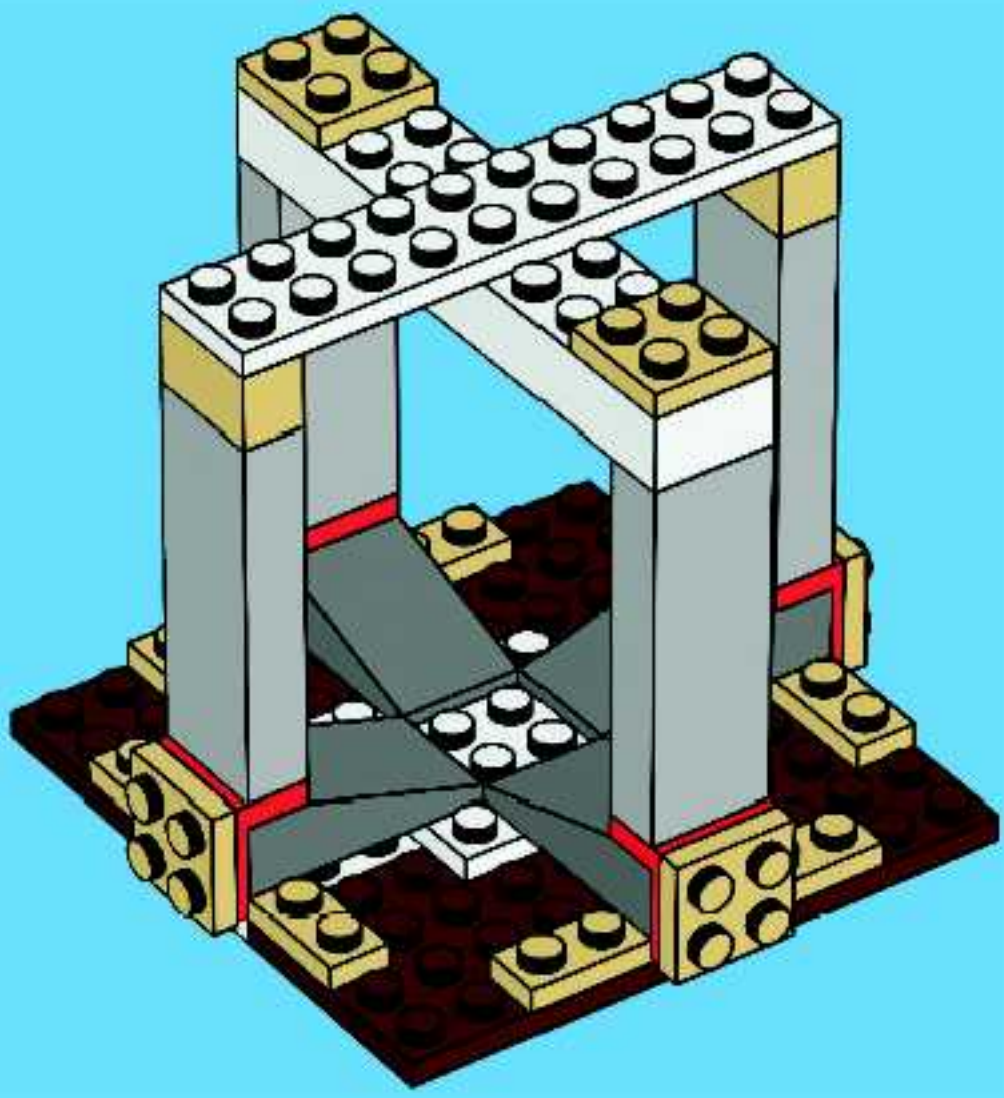



8

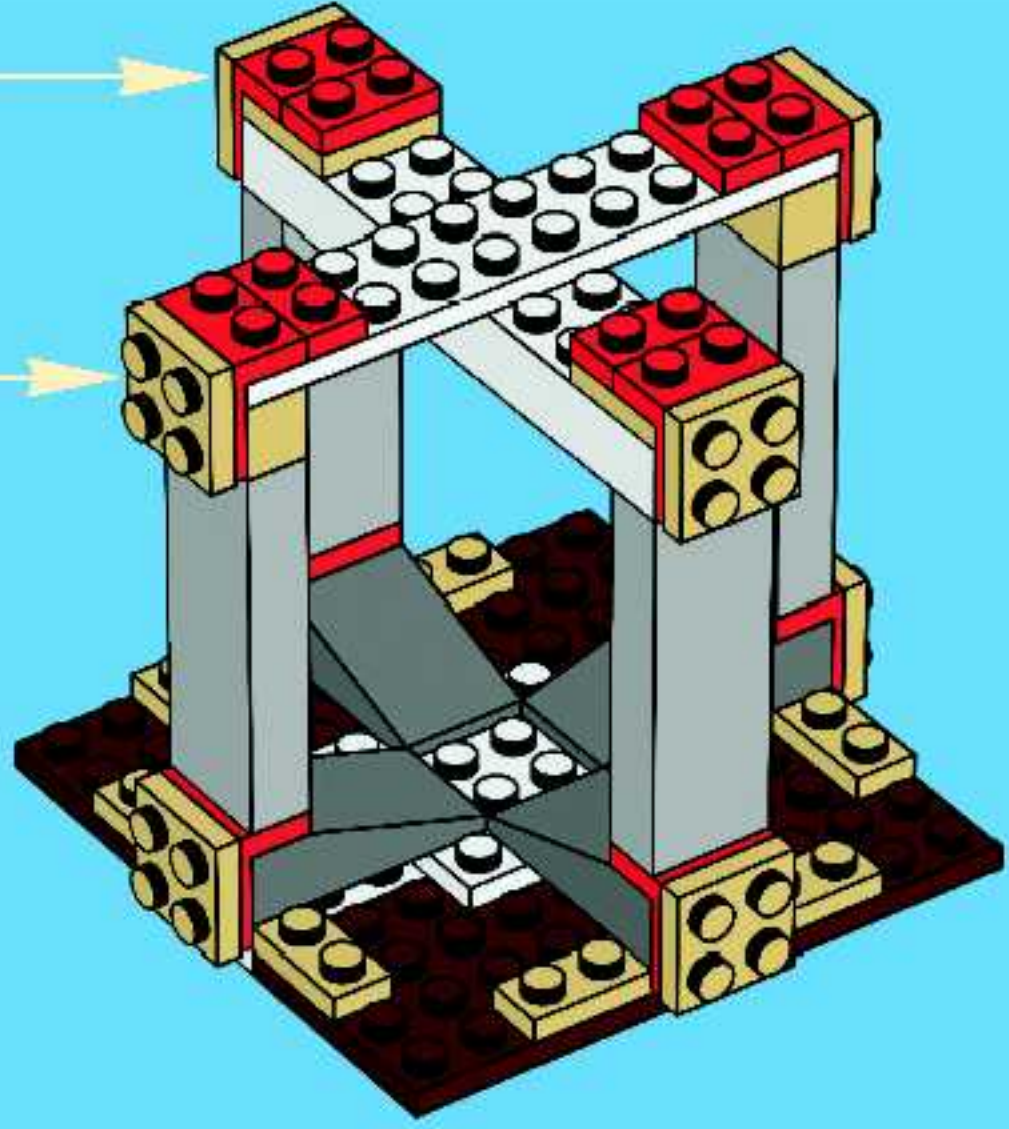
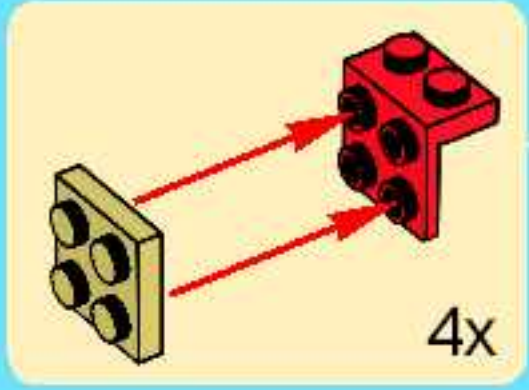

9

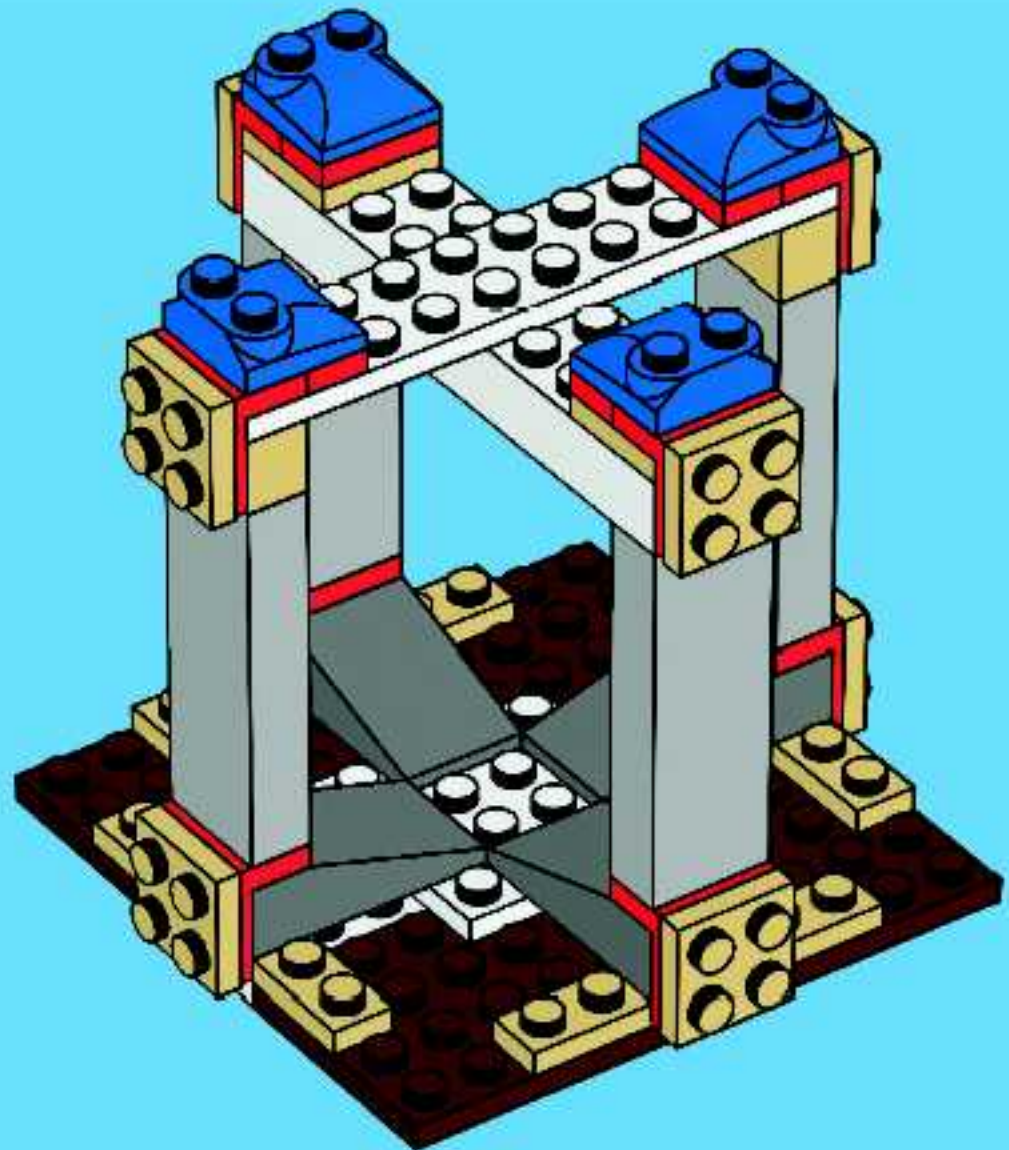

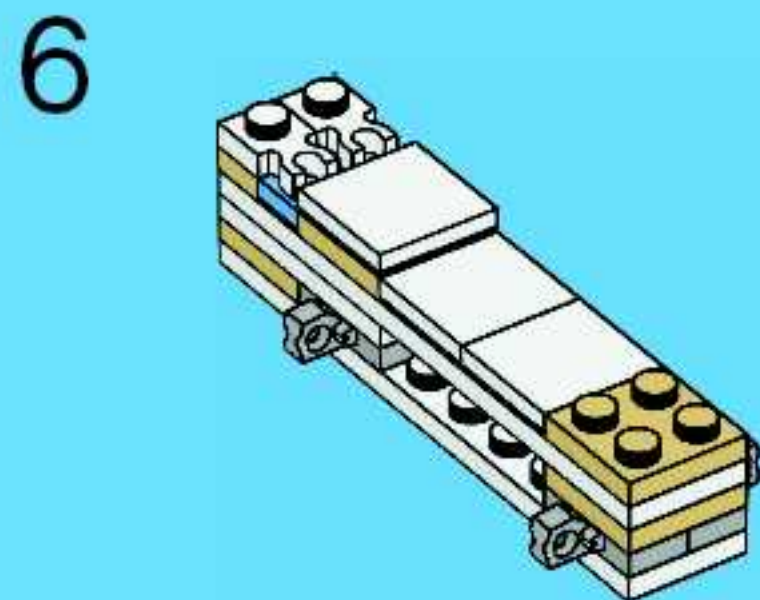
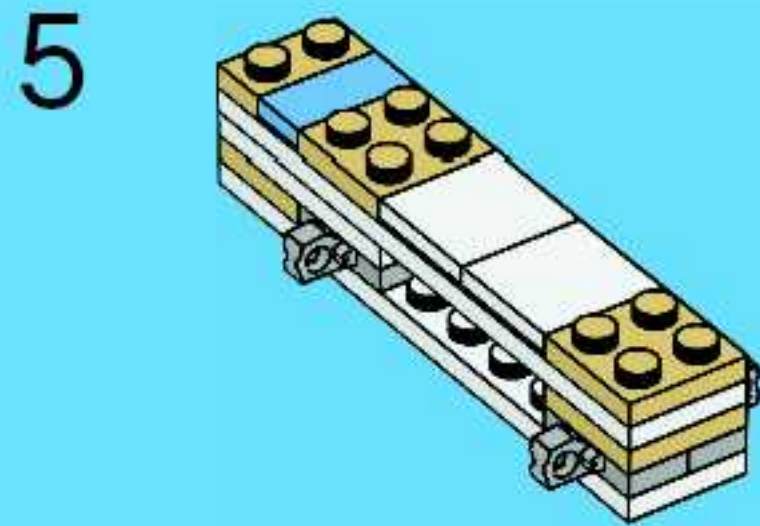
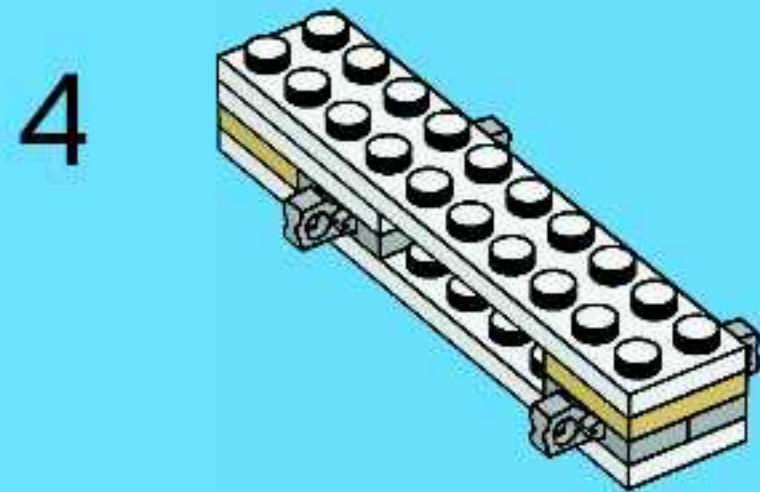
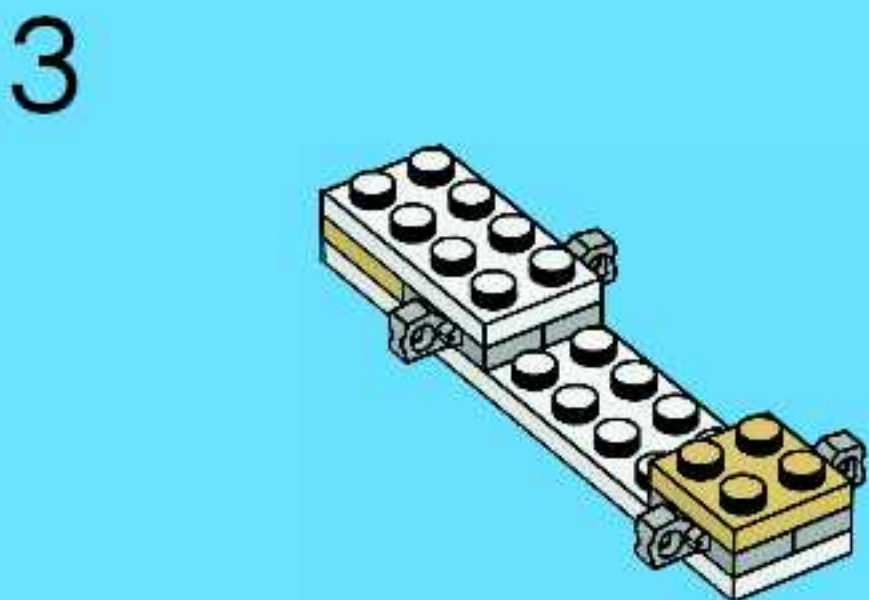
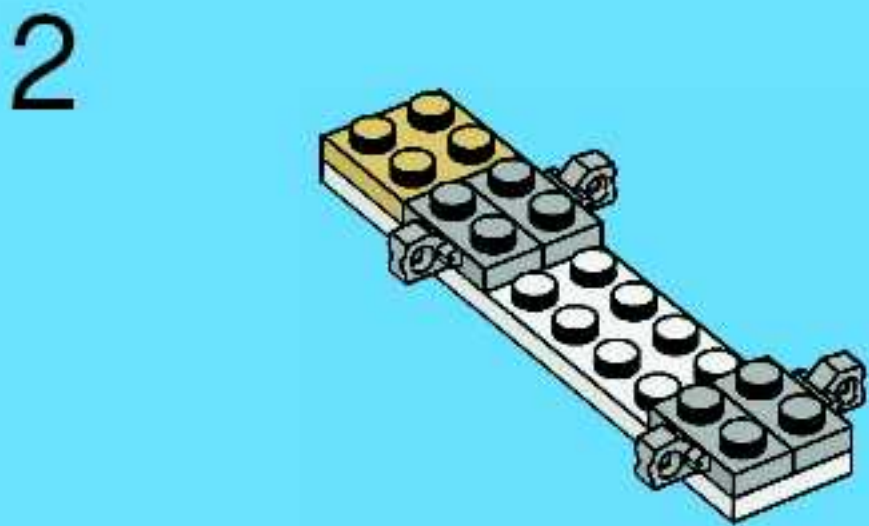
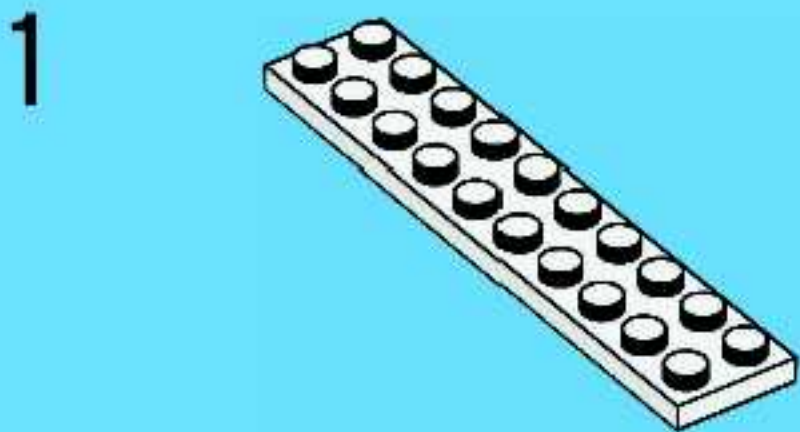
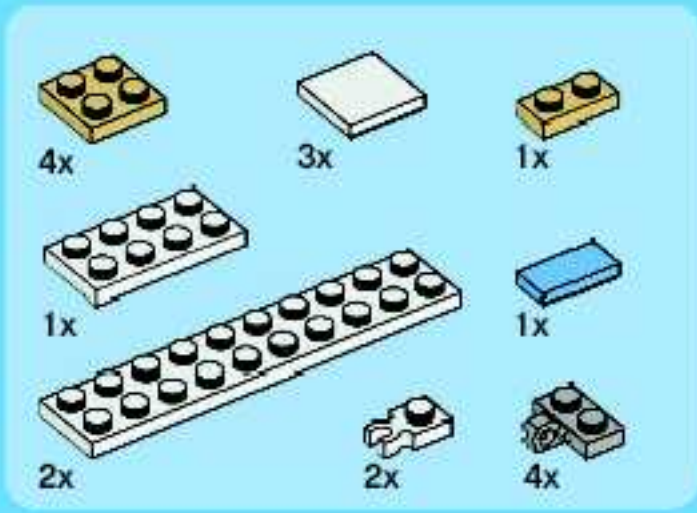
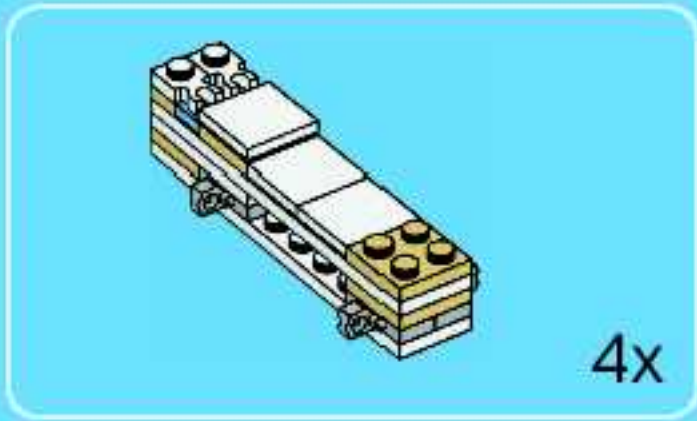



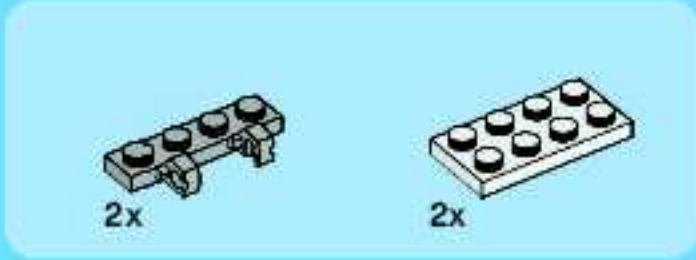
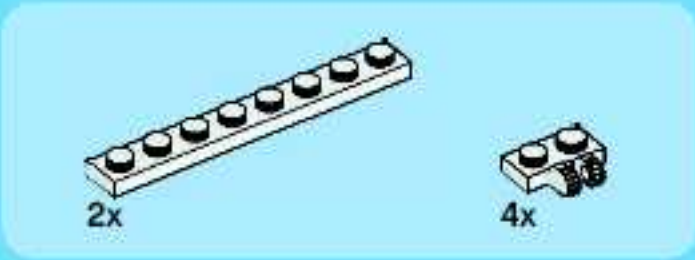
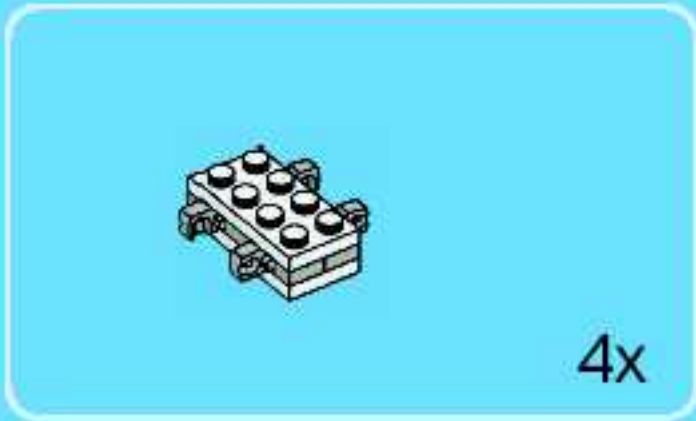
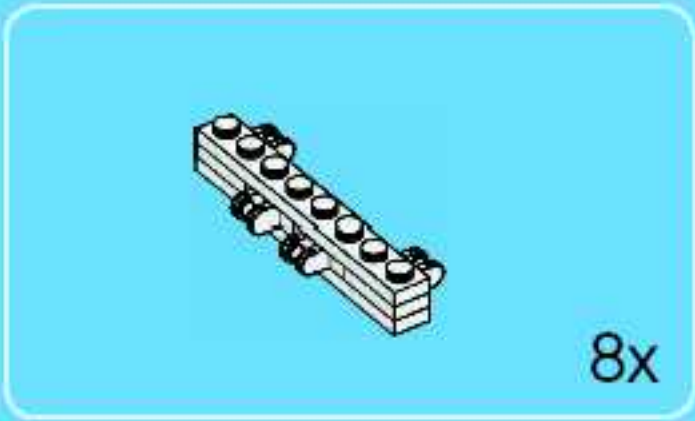

1

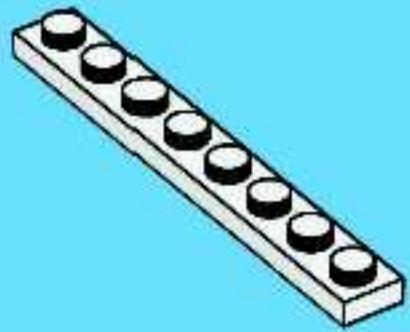

1



2

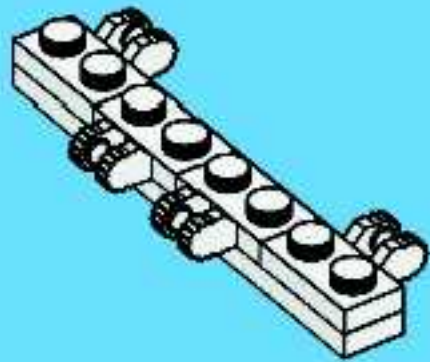

2

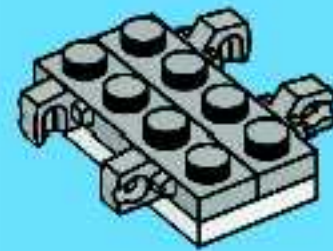

3

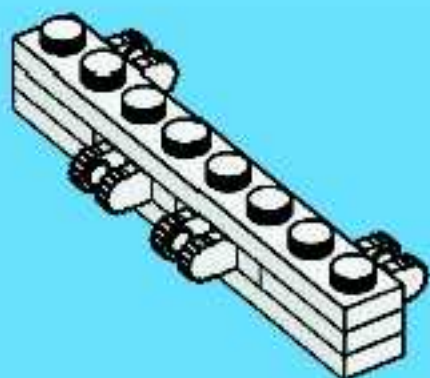

8x

3

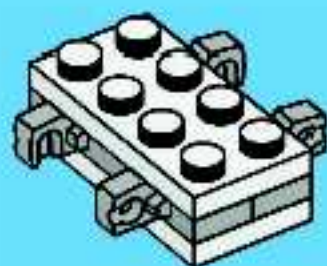

4x

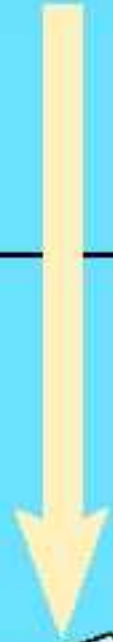
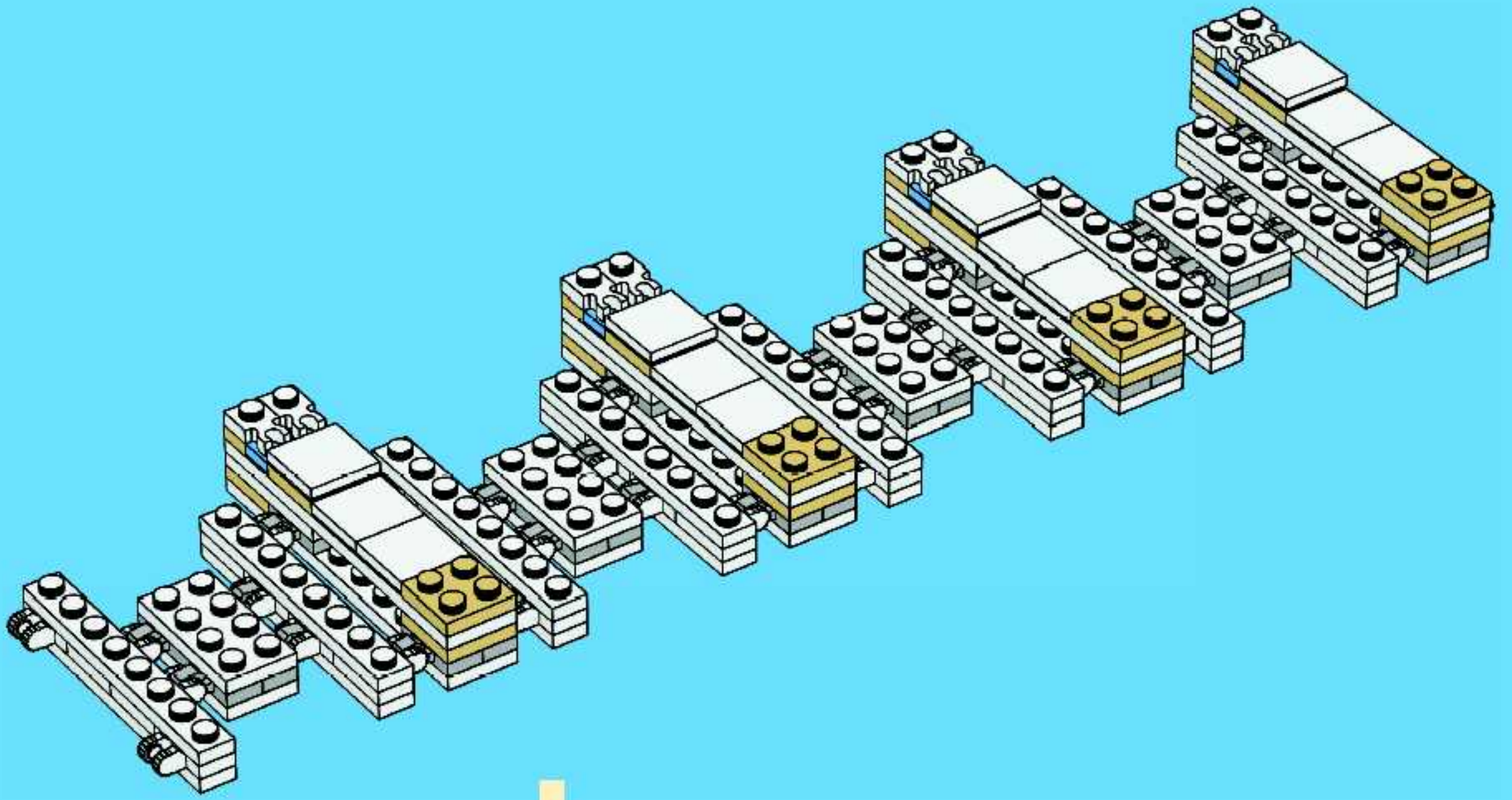

10

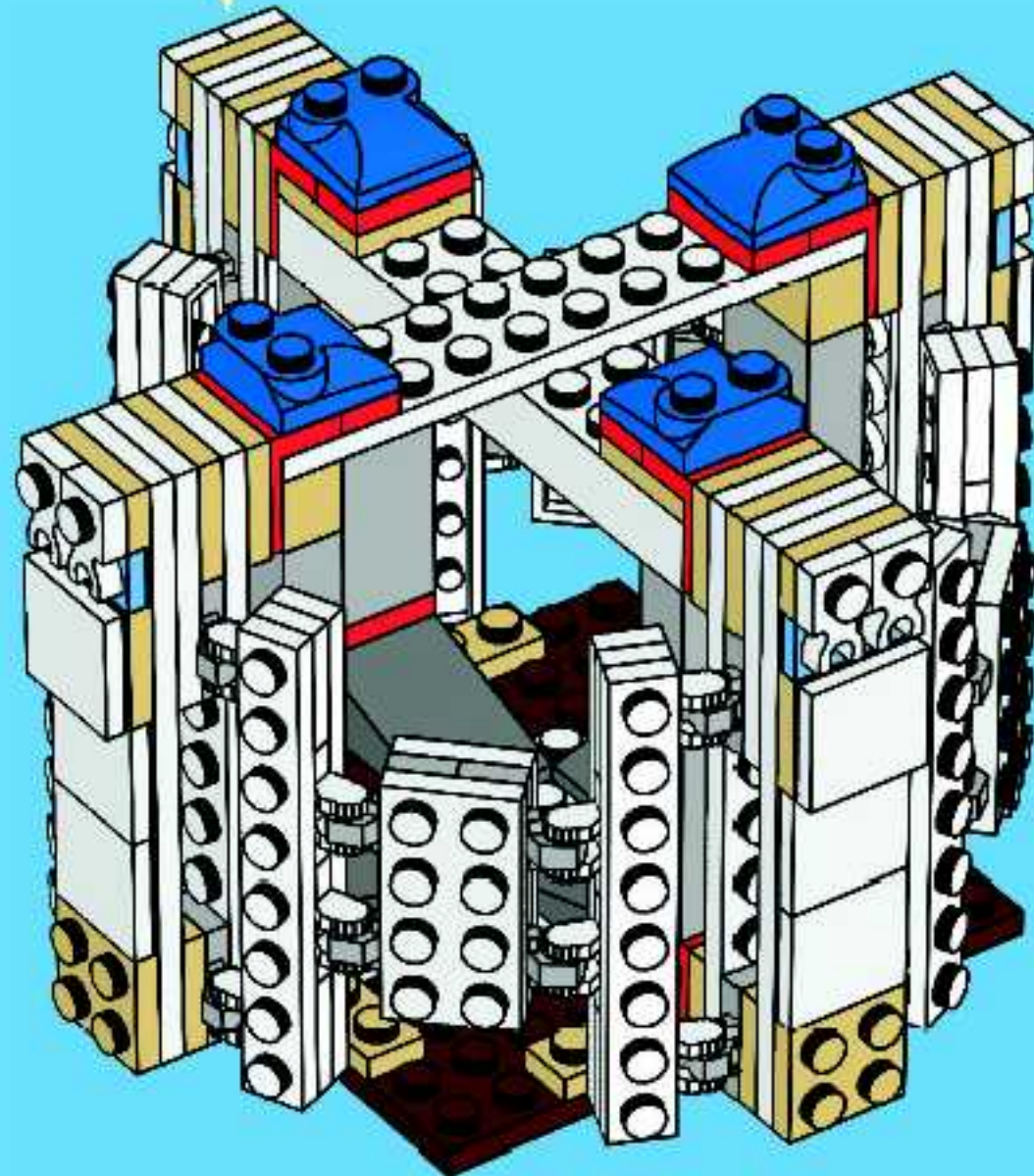

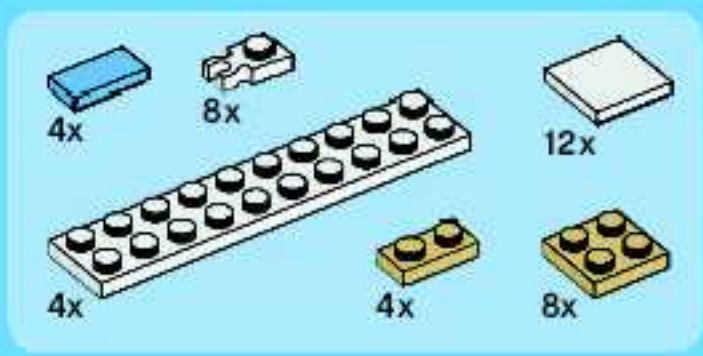

# 11

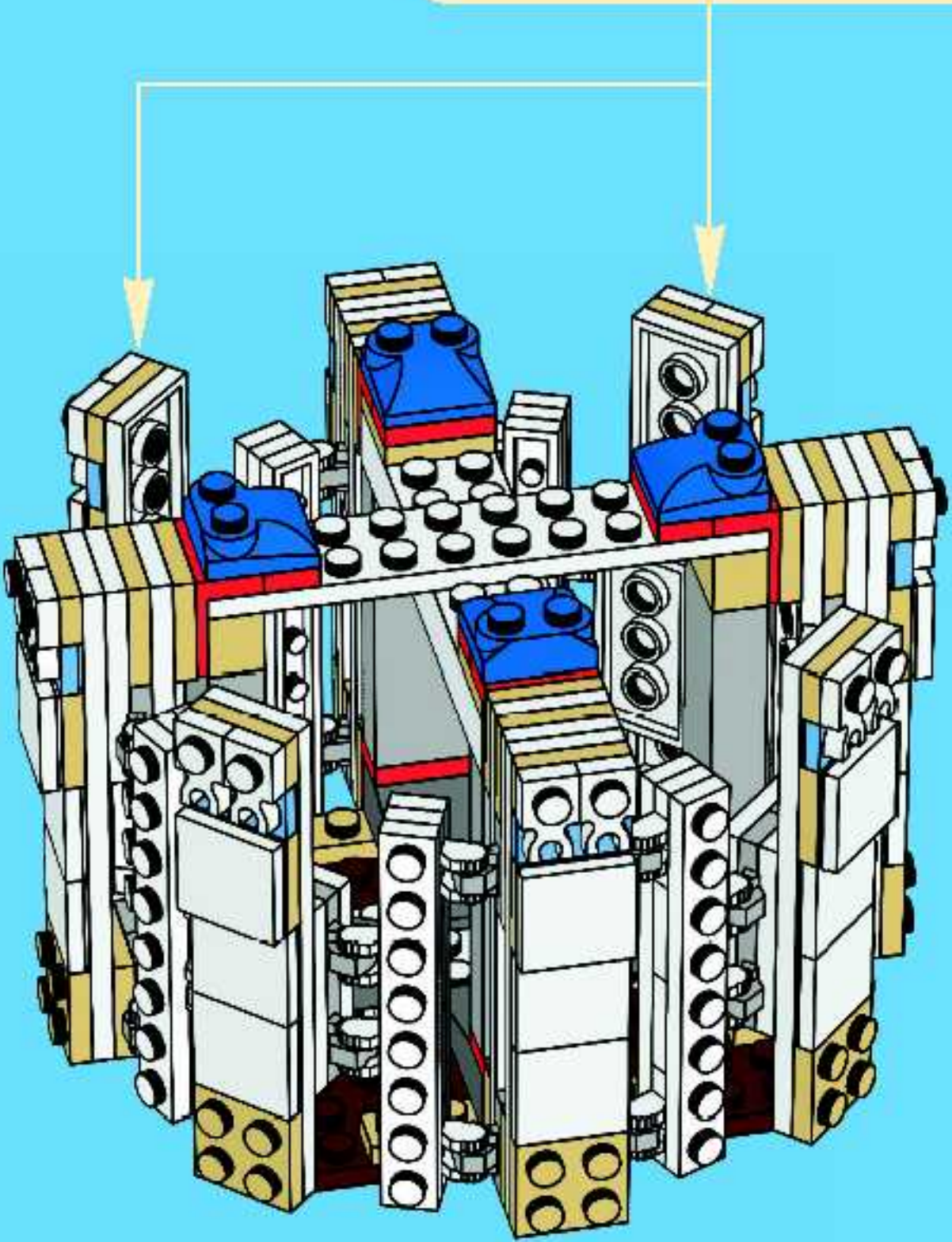
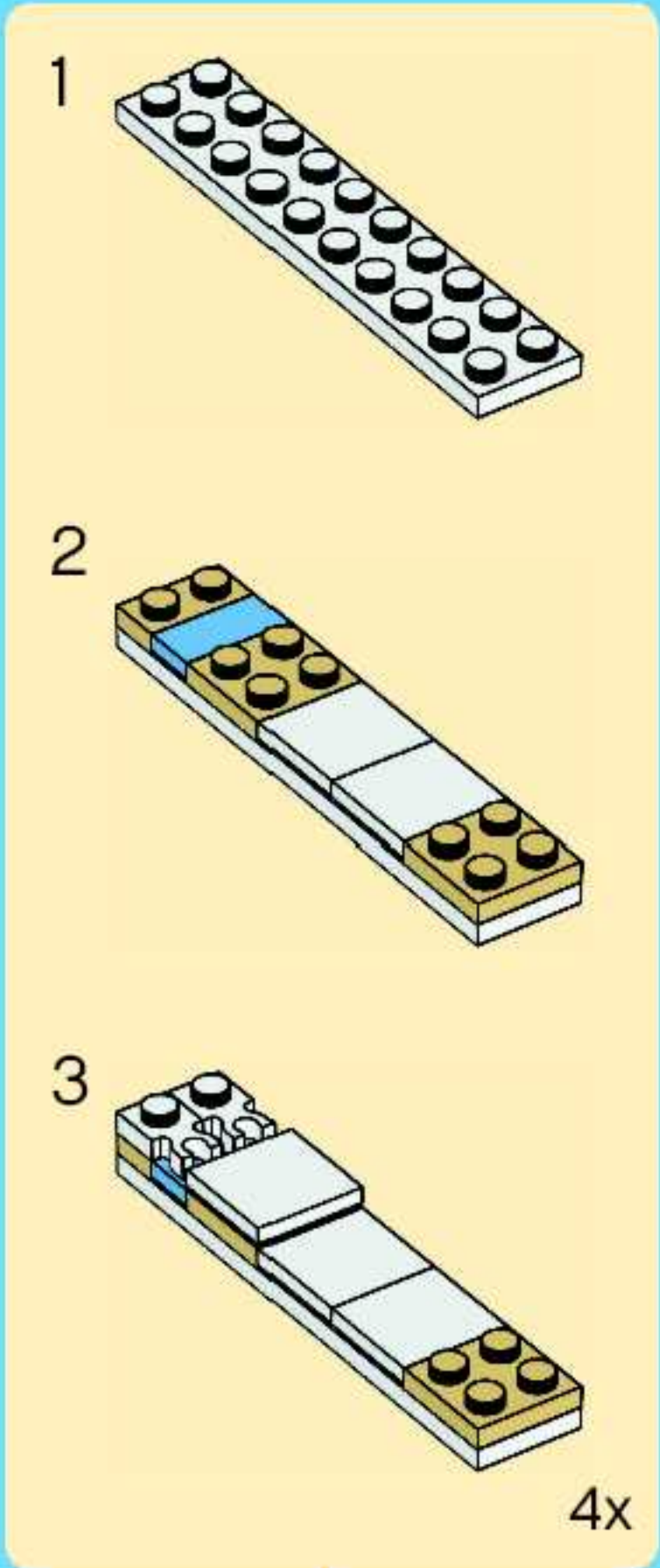

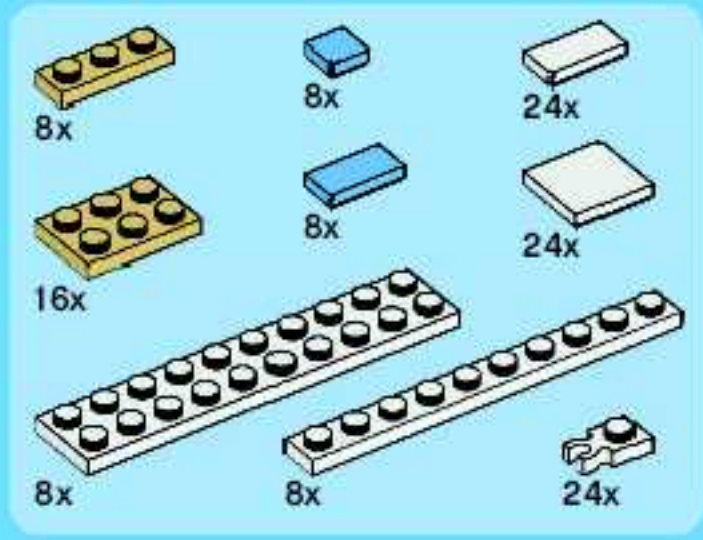

# 12

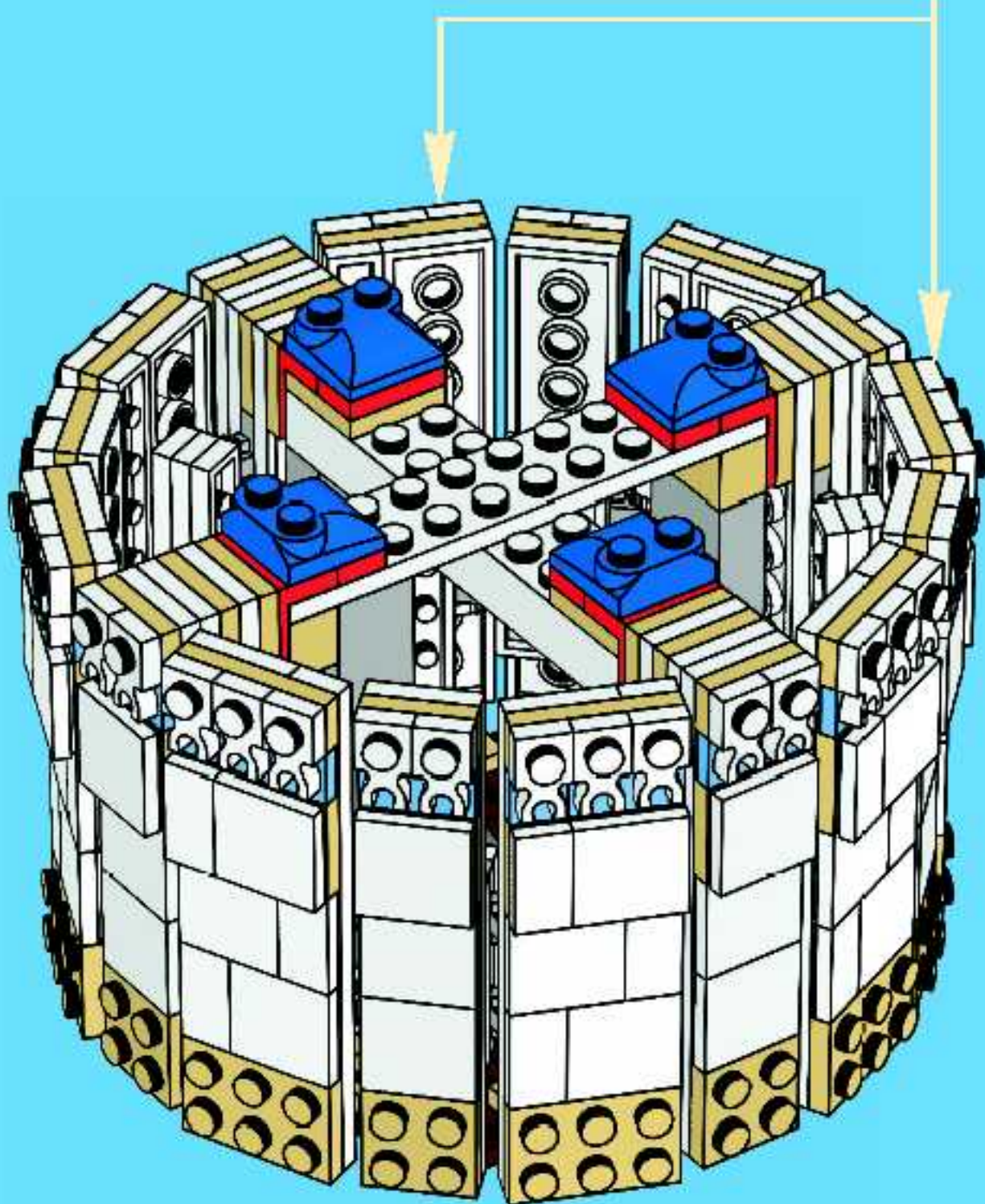
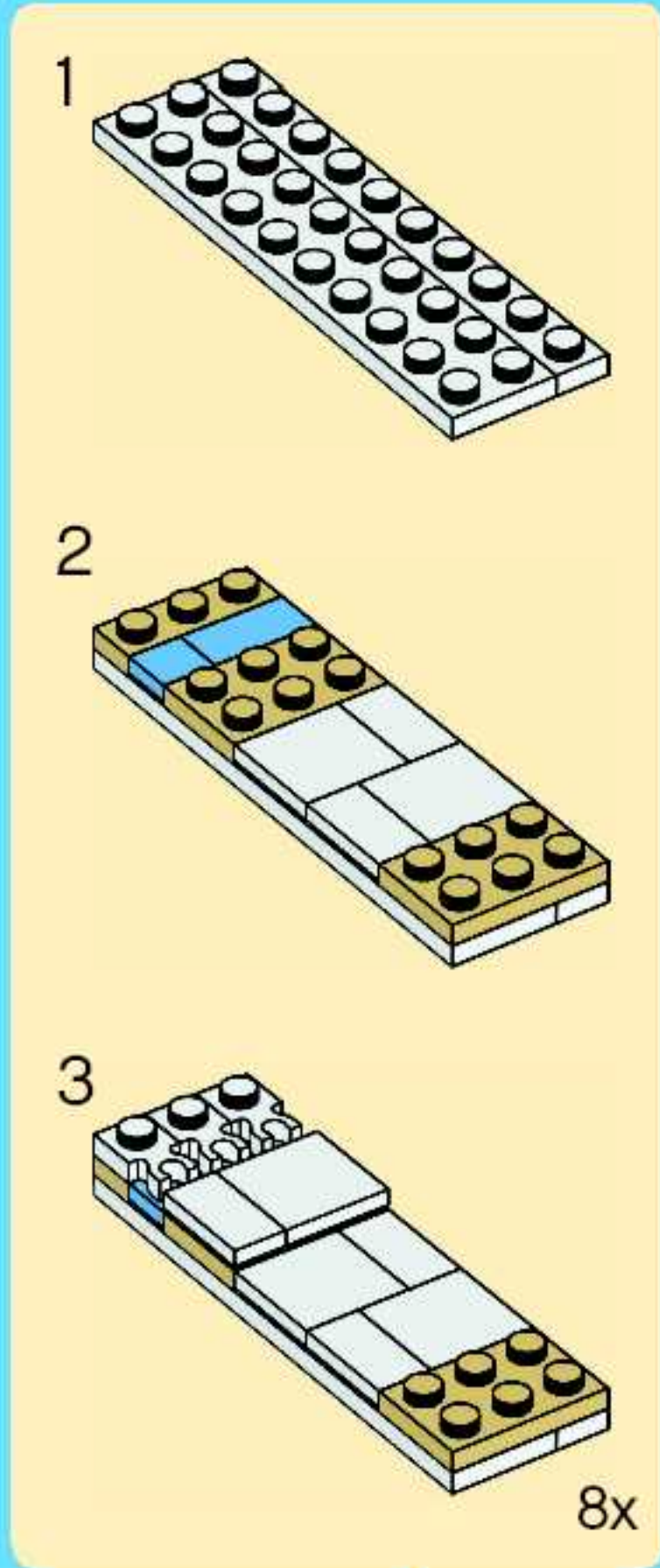



4x



3x

# 13

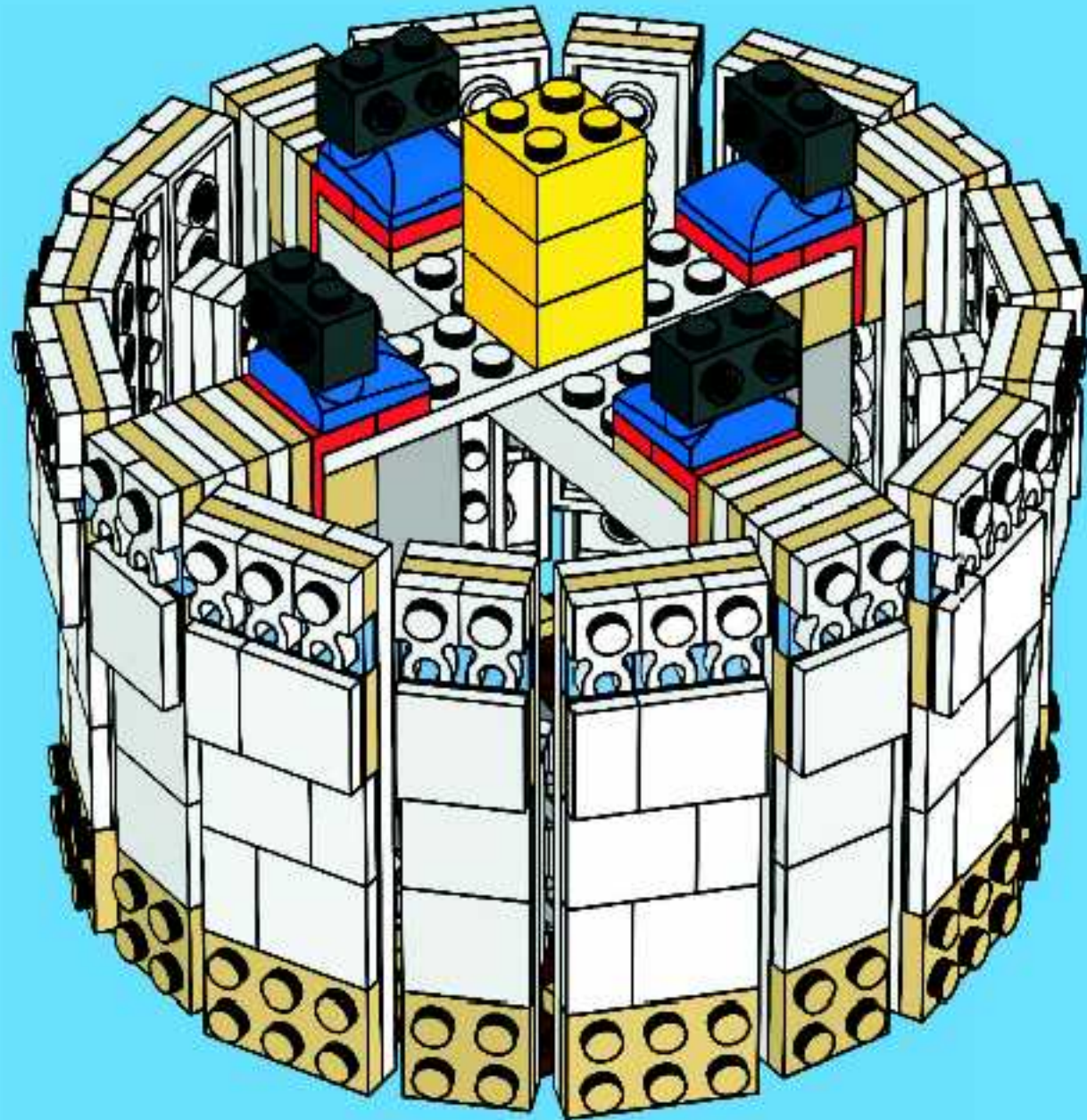



2x



4x

# 14

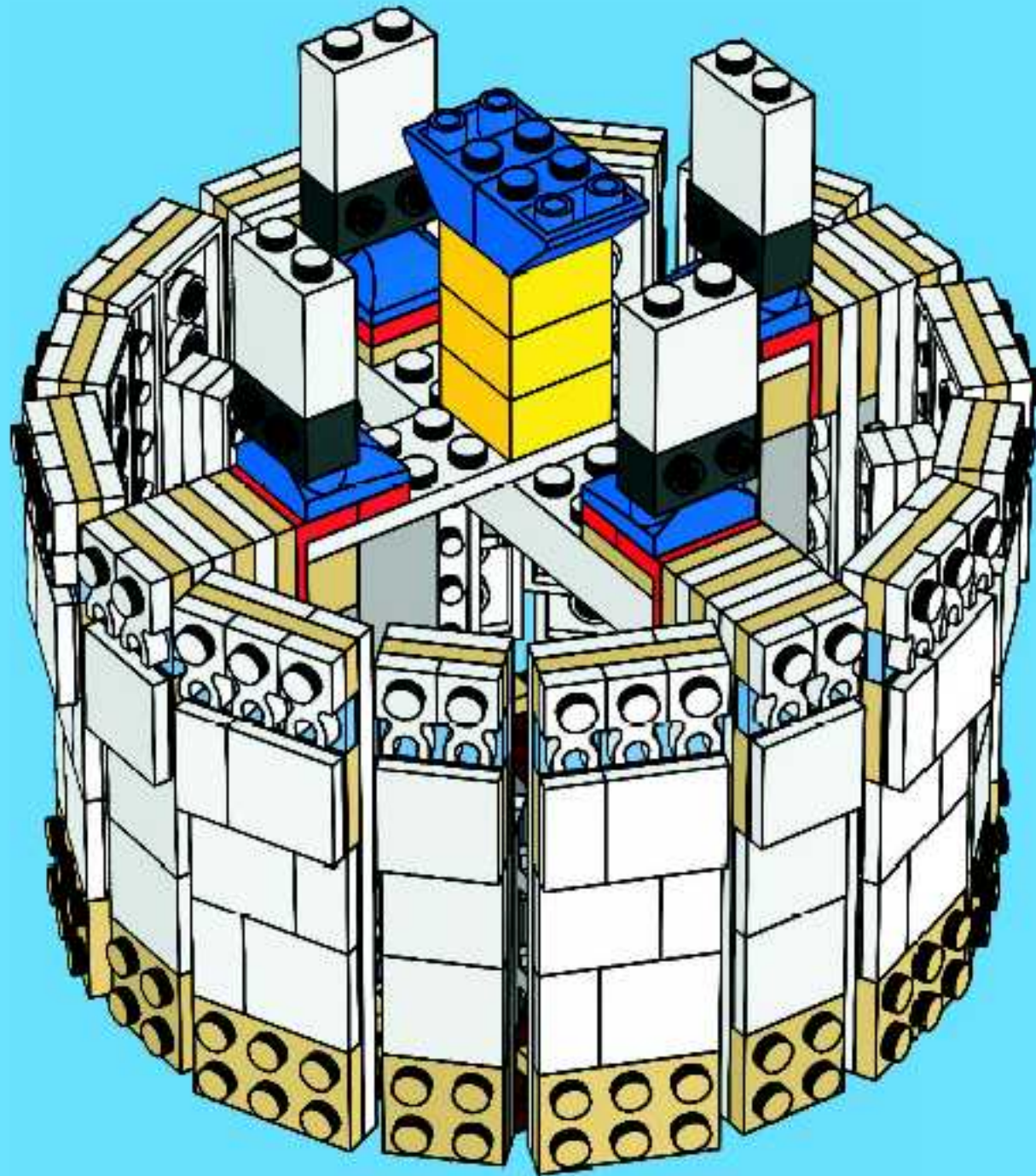

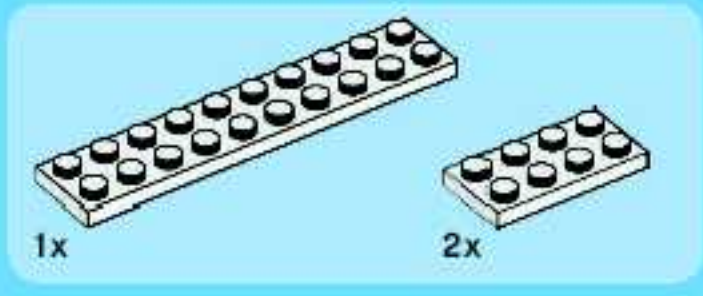

# 15

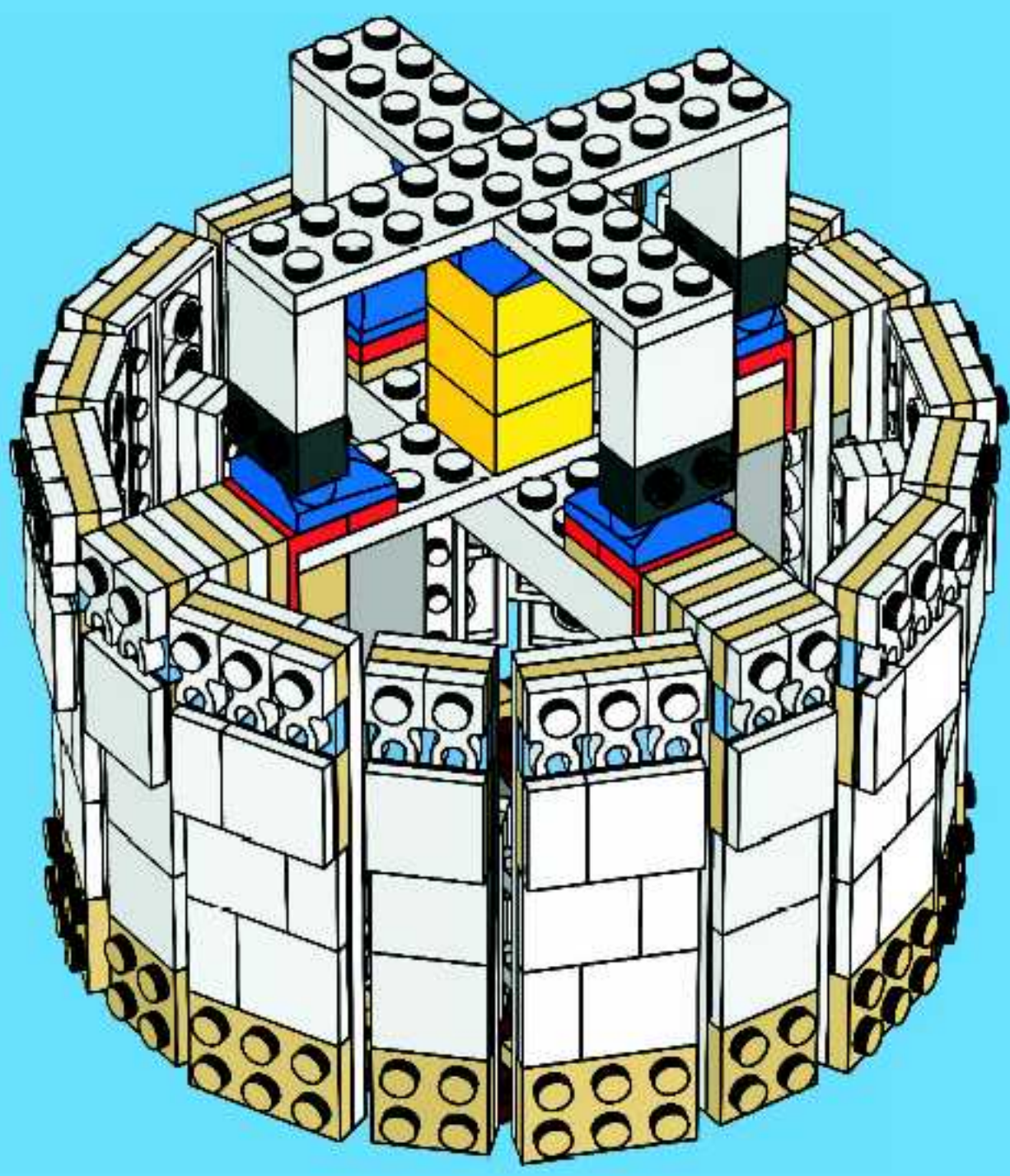



4x



4x

# 16

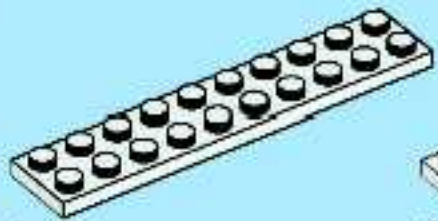
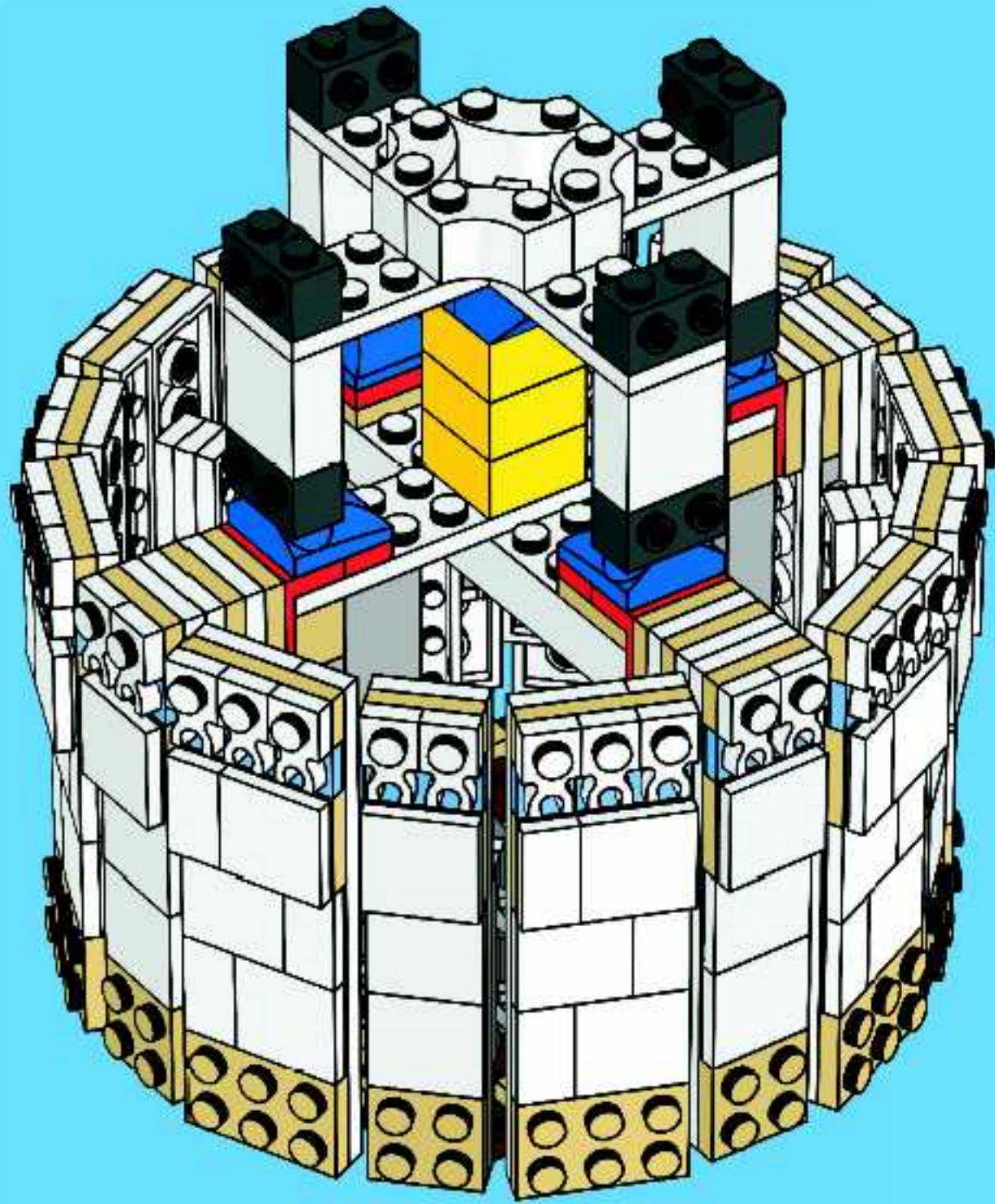

1x



2x

# 17

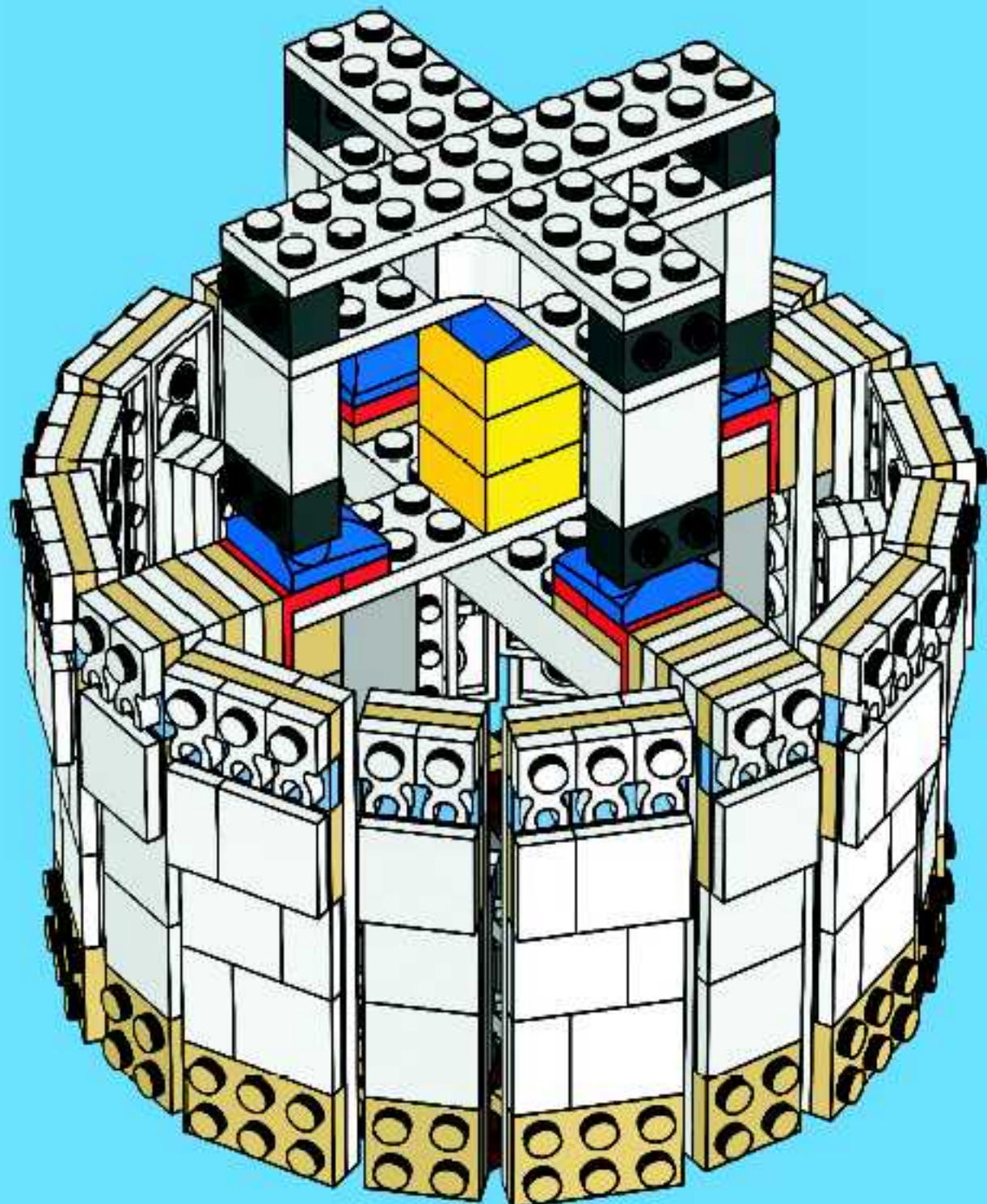





2x

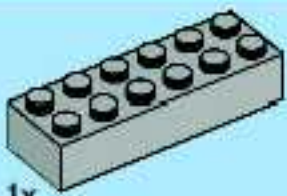

1x

# 18

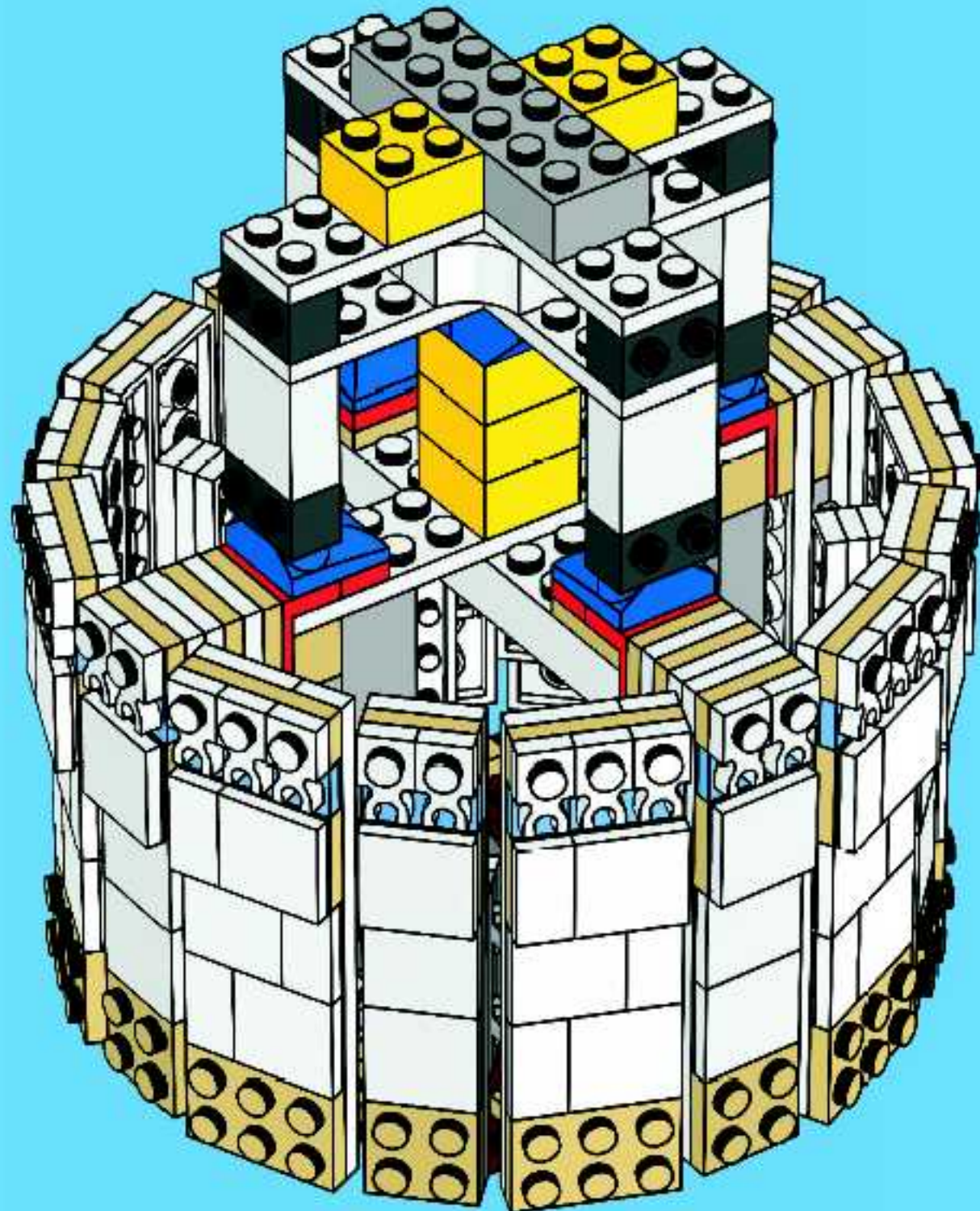



19

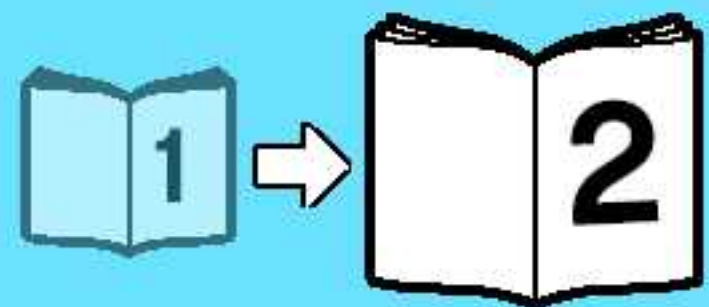
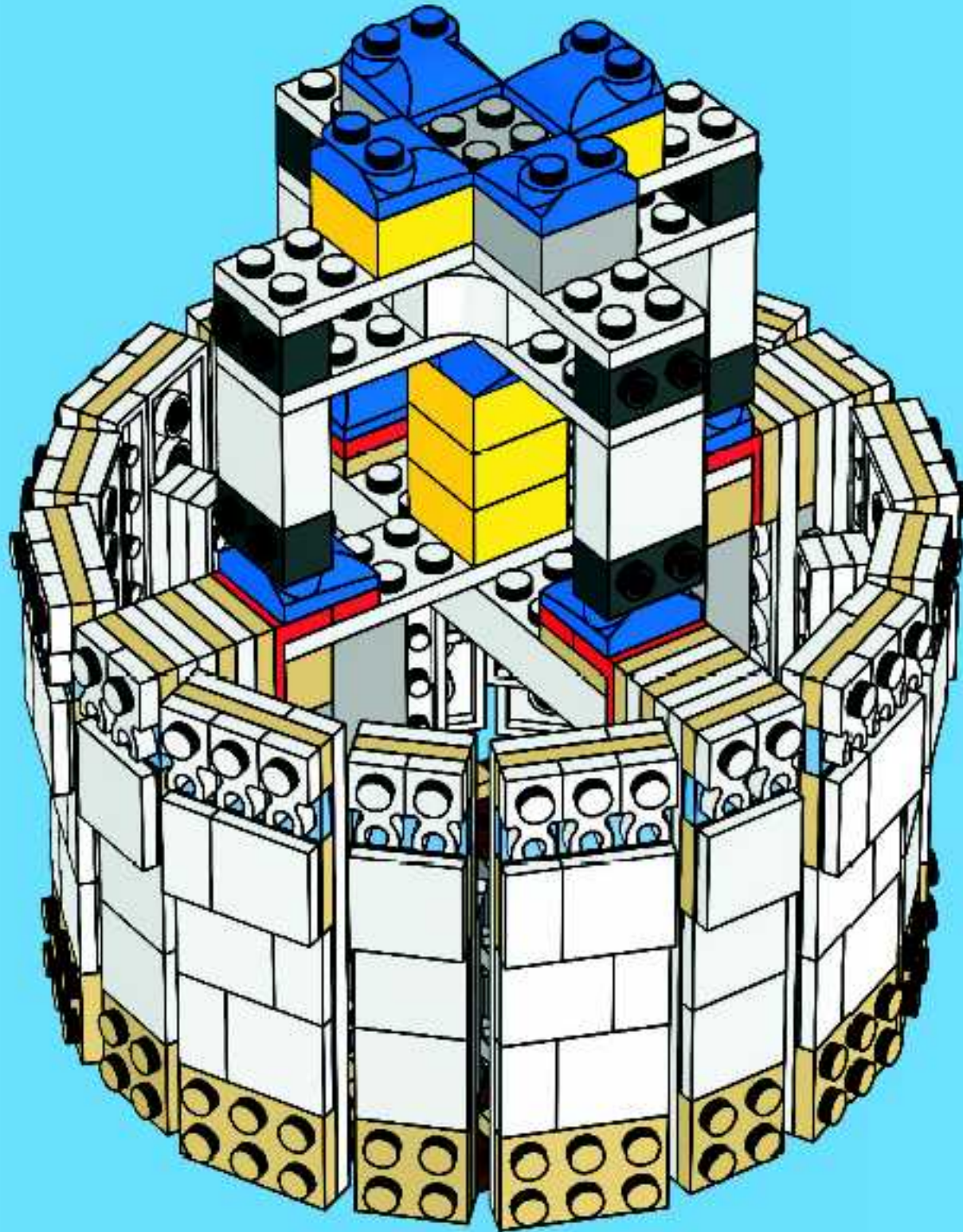



## WIN LEGO® PRODUCTS

Fill out a survey and you might WIN a cool LEGO product!  
NO PURCHASE NECESSARY

Open to all residents where not prohibited

Go to [www.acnielsen.aim.dk/LEGO](http://www.acnielsen.aim.dk/LEGO) to fill out a survey for a chance to win a LEGO product.

## WIN LEGO® PRODUCTEN

Vul een enquêteformulier in en maak kans op een cool LEGO® product!

Kopen niet nodig

Iedereen uit landen waar geen enquêteverbod geldt mag deelnemen.

Go naar [www.acnielsen.aim.dk/LEGO](http://www.acnielsen.aim.dk/LEGO), vul een enquêteformulier in en maak kans op een LEGO product.

## GEWINNE LEGO® PRODUKTE

Nimm an der Umfrage teil und GEWINNE ein tolles LEGO® Produkt!

Die Teilnahme am Gewinnspiel führt zu keinerlei

Kaufverpflichtungen

Teilnahme in allen nicht ausgeschlossenen Ländern möglich

Wir verlosen unter allen Teilnehmern der Umfrage auf

[www.acnielsen.aim.dk/LEGO](http://www.acnielsen.aim.dk/LEGO) LEGO Produkte.

## GAGNE DES PRODUITS LEGO®

Réponds à un questionnaire et tu pourrais GAGNER un produit LEGO® très cool !

Aucune obligation d'achat

Ouvert à tous les résidents des pays autorisés.

Visite [www.acnielsen.aim.dk/LEGO](http://www.acnielsen.aim.dk/LEGO) pour répondre à un

questionnaire et avoir une chance de gagner un produit LEGO.

## レゴ®製品を「当てよう」

アンケートに記入して、かっこいいレゴ®製品を当てよう！

お買い上げの必要はありません。

禁止されていない限り、すべての皆様にご利用いただけます。

[www.acnielsen.aim.dk/LEGO](http://www.acnielsen.aim.dk/LEGO)にアクセスして、アンケートにご記入ください。当選者にはレゴ®製品を差し上げます。

[www.nielsen.com/LEGO](http://www.nielsen.com/LEGO)



WIN  
WIN  
GEWINNE  
GAGNE  
「当てよう」



©2008 The LEGO Group. 4536802