



42056 Porsche 911 GT3 RS

Text: Scott Selkirk Neillands. Ulrik Feldskov Juul.

Photo/Foto: Ulrik Jantzen. Tim Trøjborg. Porsche AG.

Design: Kristian Nørby Larsen. Allan Jensen. Jakob Nusbaum.

LEGO and the LEGO logo are trademarks of the LEGO Group.

©2016 The LEGO Group.

Porsche, the Porsche Crest, 911 and GT3 are registered trademarks of Porsche AG and used under license.



Booklet available in English on
Broschüre in deutscher Sprache erhältlich auf
Livret disponible en français sur
Folleto disponible en español en
Folheto disponível em português em
A fűzet magyarul ezen a honlapon olvasható:
如需中文版手册, 请访问

4



Welcome
Willkommen

6



The Heritage of the Perfect Sports Car
Das Erbe des perfekten Sportwagens

10



Designing Perfection
Design in Perfektion

14



The Driver's Point of View
Das Fahrerlebnis

18



A Dream Project
Ein Traumprojekt

26



A Passion for Detail
Mit Liebe zum Detail

30



A LEGO® Memory
Eine LEGO® Erinnerung

34



Producing Excellence
Produktion in höchster Qualität

36



Get Ready To Build
Vorfreude auf den großen Bauspaß!

Welcome

With the introduction of the new LEGO® Technic building system in 1977, it suddenly became possible to create more complex LEGO models that mirrored the authentic features and functions of real vehicles. Throughout the years we have constructed cars, motorbikes, trucks and planes: all the time challenging ourselves to add more realistic details and elaborate working elements.

This LEGO Technic interpretation of an iconic Porsche 911 is the latest realisation of that goal. We hope you will enjoy building the model and learning more about the story behind its development. ✖

Willkommen

Als 1977 das neue LEGO® Technic Bausystem eingeführt wurde, konnten plötzlich viel komplexere LEGO Modelle erschaffen werden, in denen authentische Funktionen echter Fahrzeuge nachgebildet wurden. Über die Jahre hinweg haben wir Autos, Motorräder, Lastwagen und Flugzeuge gebaut und es uns stets zur Aufgabe gemacht, noch realistischere und aufwändigere Funktionselemente hinzuzufügen.

Die LEGO Technic Interpretation des legendären Porsche 911 ist die konsequente Umsetzung dieses Ziels. Wir hoffen, dass euch das Bauen des Modells viel Freude bereiten wird und ihr Neues zur Geschichte der Modellentwicklung erfahrt. ✖

*In the beginning I looked around
but couldn't find the car I dreamt of,
so I decided to build it myself.*

FERRY PORSCHE

*Am Anfang schaute ich mich um, konnte aber
den Wagen, von dem ich träumte, nicht finden.
Also beschloss ich, ihn mir selber zu bauen!*

FERRY PORSCHE





*Dieter Landenberger, manager of the Historical Archives of Porsche AG in the workshop of the Porsche Museum.
Dieter Landenberger, Leiter Historisches Archiv der Porsche AG, in der Werkstatt des Porsche Museums.*

The Heritage of the Perfect Sports Car

"The philosophy of the company is as unique as its cars. Every model that bears the Porsche crest on the hood must combine sporting performance with everyday usability. It's this intelligent combination of design, performance and efficiency that makes Porsche cars so special."

As manager of the Historical Archives of Porsche AG with the responsibility for the heritage of the Porsche brand, Dieter Landenberger, is perfectly placed to tell us about Porsche's design DNA and the key role the 911 model has played in the company's goal of creating the perfect sports car.

"For more than half a century the Porsche 911 has been revered as an iconic automobile and the very epitome of the sports car. The 911 has consistently gone its own way, not only in terms of design, but also with regard to technology. The timeless design of the 911 series is undoubtedly a vital element of that legacy; it blends emotion with functionality."

"The Porsche designers responsible for the seven 911 generations so far have been consistently indifferent to passing fads. On the contrary, the design has been continuously evolved taking great care to preserve its unique identity. 'Form follows function' has been a natural guiding principle throughout."

Das Erbe des perfekten Sportwagens

„Die Philosophie des Unternehmens ist genauso einzigartig wie seine Autos. Jedes Modell, das das Porsche Wappen auf der Haube trägt, muss sportliche Leistung mit Alltagstauglichkeit vereinen. Diese intelligente Kombination aus Design, Leistung und Effizienz macht die Fahrzeuge von Porsche so besonders.“

Als Leiter des Historischen Archivs der Porsche AG und mitverantwortlich für das Erbe der Marke Porsche ist Dieter Landenberger der ideale Ansprechpartner, um uns die Design-DNA von Porsche zu erläutern. Und uns die tragende Rolle des 911 bei der Verwirklichung des Unternehmensziels, einen perfekten Sportwagen zu bauen, zu erklären.

„Seit über einem halben Jahrhundert wird der Porsche 911 als legendäres Automobil verehrt und gilt als der Sportwagen überhaupt. Der 911 ist konsequent eigene Wege gegangen, nicht nur, was das Design betrifft, sondern auch bezüglich der Technologie. Das zeitlose Design der 911 Modellreihe ist ohne Frage ein entscheidendes Element dieses Erbes; hier verbinden sich Emotion und Funktionalität.“

„Die Porsche Konstrukteure, die für die sieben Generationen des 911 zuständig waren, zeigten sich konsequent unbeeindruckt von Modeerscheinungen. Vielmehr wurde das Design fortlaufend weiterentwickelt und sorgsam darauf geachtet, die einzigartige Identität des Autos zu bewahren. Dem Design-Leitsatz ‚form follows function‘ wurde mit großer Selbstverständlichkeit Rechnung getragen.“

➤ "In the course of the last fifty years our engineers have regularly reinvented the 911. With innovations such as the three-spoke safety steering wheel (1963), Targa roll bar (1965), internally ventilated disk brakes (1966), front and rear spoilers (1972), exhaust gas turbocharger (1974), hot-dip galvanised body shell (1975), intercooler (1977), Digital Motor Electronics (1983), Tiptronic (1989), aluminium chassis (1993), On-Board Diagnosis (1995), ceramic brake disks (2001), dual clutch transmission (2008), or seven-speed manual transmission (2011) – the 911 has repeatedly set new technological benchmarks.

"The 911 has always been committed to the performance principle and motor racing is its most important test lab. From the very beginning, it has been at home on circuits all over the world, earning itself a reputation as a versatile and reliable winning vehicle. It should come as no surprise to learn that a good two-thirds of Porsche's tally of 30,000 race victories to date were notched up by the 911."

"With the new 911 GT3 RS, Porsche continues the heritage of street-legal, high-performance models. For the Porsche brand these models are very important. With their extraordinary performance and sportiness they are pure drivers' cars. The new 911 GT3 RS maintains the basic idea of Ferry Porsche who once said: 'Driving enjoyment is not created by comfort, but quite the opposite.'" ❖

„Im Laufe der vergangenen fünfzig Jahre haben unsere Ingenieure den 911 immer wieder neu erfunden. Mit Innovationen wie dem Dreispeichen-Sicherheitslenkrad (1963), dem Targa Überrollbügel (1965), den innenbelüfteten Scheibenbremsen (1966), dem Front- und Heckspoiler (1972), dem Abgasturbolader (1974), der feuerverzinkten Karosserie (1975), dem Ladeluftkühler (1977), der digitalen Motorelektronik (1983), der Tiptronic (1989), dem Aluminium-Fahrwerk (1993), dem On-Board-Diagnosesystem (1995), den Keramik-Bremsscheiben (2001), dem Doppelkupplungsgetriebe (2008) oder dem Siebengang-Schaltgetriebe (2011) hat der 911 immer wieder neue Maßstäbe in der Fahrzeugtechnik gesetzt.“

„Das Leistungsprinzip war seit jeher ein Fixpunkt, und der Motorsport ist noch heute sein wichtigstes Testlabor. Von Beginn an war der 911 auf den Rennstrecken rund um den Globus zuhause und hat sich seinen Ruf als vielseitiges und zuverlässiges Siegerfahrzeug erworben. Es überrascht daher nicht, dass in der Bilanz aller 30.000 Rennsiege von Porsche gute zwei Drittel auf den 911 entfallen.“

„Mit dem neuen 911 GT3 RS setzt Porsche das Erbe der Hochleistungsmodelle mit Straßenzulassung fort. Für die Marke Porsche sind diese Modelle äußerst wichtig.“

Mit ihrer herausragenden Leistung und Sportlichkeit sind sie reine „drivers' cars“. Der neue 911 GT3 RS wurde ganz nach der Devise von Ferry Porsche konstruiert, der einmal gesagt hat: „Fahrspaß wird nicht durch Komfort erzeugt – das Gegenteil ist der Fall.“ ❖



1973: 911 Coupé (Original 911)/1973: 911 Coupé (Ur-911)



1992: 911 Carrera 2 Targa (Type 964)/1992: 911 Carrera 2 Targa (Typ 964)



1974: 911 Carrera Coupé (G Series)/1974: 911 Carrera Coupé (G-Serie)



2001: 911 Carrera Coupé (Type 996)/2001: 911 Carrera Coupé (Typ 996)



Designing Perfection

If the address 'Porsche Straße 911' is not enough in itself, the roaring sounds from the nearby test track will soon convince you that the Porsche Development Center at Weissach, close to Stuttgart, is a very special place. This is where all Porsches are designed and tested, and concepts like the Porsche 911 GT3 RS are refined to perfection by the Head of GT Cars, Andreas Preuninger, and his team of designers, engineers and mechanics.

As the leader of the team responsible for the current range of GT cars at Porsche, there is no one better than Mr Preuninger to describe why the latest Porsche 911 GT3 RS is such a special driving experience.

"First of all, the base car we start from – the 911 – is without a doubt the best driver's car in the world. Secondly, we shouldn't forget that we make the car better for the specific needs of our special target group and not necessarily for everybody. The focus is to make the car a true driver's car without having to care about all the compromises a more all-round sports car has to consider."

Design in Perfektion

Wenn die Adresse „Porschestraße 911“ als Hinweis nicht ausreicht, dann sind es die dröhnenden Motoren von der nahegelegenen Teststrecke, die den eindeutigen Beweis dafür liefern, dass das Porsche Entwicklungszentrum in Weissach bei Stuttgart ein ganz besonderer Ort ist. Hier befindet sich neben der Entwicklungs- und Testzentrale für alle Porsche auch der Motorsportbereich. Und genau dort werden Hochleistungssportwagen wie der 911 GT3 RS von GT-Chef Andreas Preuninger und seinem Team aus Konstrukteuren, Ingenieuren und Mechanikern konzipiert.

Andreas Preuninger kann als Leiter des Teams, das für die aktuelle Serie von GT-Straßenfahrzeugen bei Porsche verantwortlich zeichnet, besser als jeder andere erläutern, warum der neueste 911 GT3 RS ein derart besonderes Fahrerlebnis vermittelt.

„Zuerst einmal ist die Basis, auf der wir aufsetzten, der 911, ohne Zweifel das beste „driver's car“ der Welt. Dabei sollten wir nicht vergessen, dass wir das Auto für die besonderen Anforderungen unserer speziellen Zielgruppe optimieren, also nicht unbedingt für jeden Fahrer. Der Schwerpunkt unserer Arbeit liegt darin, den Wagen zu einer echten „Fahrmaschine“ zu machen, ohne Kompromisse eingehen zu müssen, die bei anderen, eher alltagstauglicheren 911 Modellen unumgänglich sind.“

Andreas Preuninger (right), Head of GT Cars, discusses the model with Senior LEGO Designer Uwe Wabra.

Andreas Preuninger (rechts), Gesamtprojektleiter GT-Straßenfahrzeuge bei Porsche, bespricht das Modell mit Senior LEGO Designer Uwe Wabra.

- "The car has to transmit a lot of information to the driver, melt into one with him and give him that seat-of-the-pants feeling; it has to become his prolonged arm. Another important point is the mechanical character of all the technology involved; it's not a bad thing if you feel and hear the valves hissing, gears turning or even whining, that gives the car identity and character... Some edges here and there are welcome in a true motoring car."

"It's important for us that the car has to be pleasing to the eye, while also looking purposeful and mildly aggressive... But all the components have to function efficiently to make the car perform as well as possible. It's 'form follows function', but only if the form looks cool, if you know what I mean."

So what did Mr Preuninger think when he saw the final LEGO Technic version of his car? "I was astonished about how much resemblance could be achieved to the real car just using LEGO components. The specific creases in the hood and roof, the openings in the fenders, the big wing and air intakes are all there, so you can see at first glance this is an RS. The way working features such as the paddle-shift PDK gearing system have been integrated into the model is just amazing." ☺

„Das Auto muss dem Fahrer eine Menge an Informationen übermitteln, mit ihm eins werden, sich passgenau anfühlen – es muss zu seinem verlängerten Arm werden. Ein wichtiger Punkt dabei sind die mechanischen Eigenschaften der eingesetzten Technik. Es ist gar nicht schlecht, wenn man als Fahrer wahrnimmt, wie z.B. die Ventile arbeiten, oder Zahnräder ineinander greifen, denn das verleiht dem Auto Identität und Charakter. Hier und da ein paar „Ecken und Kanten“ sind in einem echten Sportwagen durchaus erwünscht.“

„Natürlich ist es auch wichtig, dass das Auto sehr ästhetisch aussieht, dass es trotz aller Funktionalität bestimmt auftritt und einen gewissen Aufforderungscharakter hat. Aber am Ende geht es darum, dass alle Komponenten effizient zusammenarbeiten und das Fahrzeug so die bestmögliche Performance bieten kann. „Form follows function“ ist also gefragt, solange die Form auch „cool“ rüberkommt, wenn Sie verstehen, was ich meine.“

Und was war Andreas Preuningers Eindruck, als er die endgültige LEGO Technic Version seines Autos sah? „Es hat mich erstaunt, wie viel Ähnlichkeit durch die reine Verwendung von LEGO Teilen mit dem echten Auto erreicht wurde. Die ganz speziellen Falzlinien auf der Motorhaube und dem Dach, die Öffnungen in den Kotflügeln, die großen Flügel und die Lufteinlässe finden sich alle im Modell wieder. Es ist sofort ersichtlich, dass es einen RS darstellt. Und wie realistisch verschiedene Funktionen im Modell integriert sind, ist einfach unglaublich. Bestes Beispiel: das Porsche Doppelkupplungsgetriebe mit Schaltpaddles.“ ☺



*To be truly aesthetic, truly timeless,
any design must be functionally justified.*
FERRY PORSCHE



*Die Schönheit des Porsche Designs
ist seine Zweckmäßigkeit. Alles an dem
Auto ist funktionell.*
FERRY PORSCHE







The Driver's Point of View

It may seem a long way from the karting tracks in his native New Zealand to the professional race circuits of Le Mans and Daytona, but for racing driver Brendon Hartley the goal has always been the same: "I want to win. In everything I do."

As a Porsche Works driver and a member of one of the most successful endurance racing teams competing today, the 26-year-old lives and breathes for anything with four wheels and an engine.

Brendon clearly remembers his first impressions of a car that has often been described as the closest you can get to a race car for the road: "The 911 GT3 RS is the first road car I have driven that gave me goose pimples. I only drove it from Weissach to a hotel down the road, but all my senses were overloaded with joy: the sound, the vibration when the revs got close to the red line, the feeling

Das Fahrerlebnis

Es mag ein langer Weg von den Kartbahnen seiner Heimat Neuseeland zu den Rennstrecken der Profis in Le Mans und Daytona gewesen sein, aber Rennfahrer Brendon Hartley hatte immer nur eins im Sinn: „Ich möchte gewinnen. Bei allem, was ich tue.“

Als Porsche Werksfahrer und Teil eines der erfolgreichsten Motorsport-Teams, das sich heute in Langstreckenrennen unter Beweis stellt, begeistert sich der 26-Jährige für alles, was vier Räder und einen Motor hat.

Brendon Hartley kann sich noch gut an seine ersten Eindrücke von dem Auto erinnern, das allgemein als bestmögliche Straßenversion eines Rennwagens gilt:

„Der 911 GT3 RS ist der erste Sportwagen, bei dem ich beim Fahren Gänsehaut bekommen habe. Ich bin nur von Weissach in den nächsten Ort gefahren, aber mich durchströmte sofort ein Glücksgefühl: der Sound und die Vibrationen, wenn die Nadel des Drehzahlmessers bis kurz vor den roten Bereich hochschnellt, unglaublich.“

Porsche Works driver, Brendon Hartley. Winner of the FIA World Endurance Driver's Championship 2015.

Porsche Werksfahrer Brendon Hartley, Gewinner des Fahrertitels in der FIA Langstrecken-Weltmeisterschaft 2015.



of the road through the steering wheel, the low, race-car-like position – it all gave me flash backs of the thrills of being in a race car, yet I could take this down the road for the grocery shopping!"

"The car has more down-force, more mechanical grip from the tyres, more horsepower and more muscle, which means it's hard for anybody not to do a double-take as it passes."

His meeting with the LEGO Technic version of the car was also a positive experience, and one that brought back memories of his childhood: "It's amazing. My brother and I were big LEGO enthusiasts as kids, so when I saw this I immediately thought of all the fun I would have pulling it apart and putting it back together. After the initial delight at the way it looked and the fact that they could really convey the lines of the 911 GT3 RS with standard LEGO Technic parts, I was then impressed to see a fully working gearbox and engine."

"My only question after that was: when can I have one?"

Man spürt die Straße über das Lenkrad und sitzt durch die niedrige Position wie in einem Rennwagen. Das alles brachte sofort den Nervenkitzel eines Rennens zurück. Und trotzdem konnte ich mit diesem Auto einfach die Straße entlang zum Einkaufen fahren!"

„Das Auto hat einen wahnsinnigen Anpressdruck, mehr mechanischen Grip und noch mehr Leistung. Wenn es vorbeifährt, kann man gar nicht anders, als ihm hinterherzusehen.“

Seine Begegnung mit der LEGO Technic Version des Autos war ebenfalls eine schöne Erfahrung, die Erinnerungen an seine Kindheit weckte: „Es ist erstaunlich. Mein Bruder und ich waren als Kinder große LEGO Fans. Bei diesem Anblick habe ich sofort gedacht, wie viel Spaß wir gehabt hätten, es auseinanderzunehmen und wieder zusammenzubauen. Mir gefällt, wie er aussieht. Die gelungene Linienführung des 911 GT3 RS aus LEGO Technic Standardteilen ist beeindruckend. Aber das voll funktionstfähige Getriebe und der Motor haben mich am meisten beeindruckt.“

„Die einzige Frage, die noch bleibt ist: Wann kann ich so einen haben?“



*Andrew Woodman, Senior Design Manager for LEGO Technic, at the Porsche production line.
Andrew Woodman, Senior Design Manager für LEGO Technic, an der Produktionslinie bei Porsche.*

A Dream Project

If you have just a quick chat with Senior Design Manager for LEGO Technic, Andrew Woodman, you won't be in any doubt that this guy has a strong passion for sports cars – and not least the Porsche 911.

"To me it's fantastic to be able to combine my job and my interest for anything related to car design and performance, so when we started to discuss the idea for this new LEGO Technic concept, we were determined to create more than just a great building experience. We wanted every aspect of this concept to be special and drive a real desire in fans to own and build it.

"To do this we knew we needed a partner with the perfect vehicle that was both highly desirable and a true icon. We reached out to Porsche as we dreamt of having a Porsche 911 as our first model. From our very first meeting it was clear that Porsche shared the same passion for the vision of this concept and together we decided upon using the latest 911 GT3 RS as the first vehicle in this LEGO Technic series."

Ein Traumprojekt

Ein kurzes Gespräch mit Andrew Woodman, Senior Design Manager für LEGO Technic, reicht aus, um seine ausgeprägte Leidenschaft für Sportwagen zu entdecken – nicht zuletzt für den Porsche 911.

„Für mich ist es einfach fantastisch, meine Arbeit und mein Interesse an allem, was mit Design und Leistung von Autos zu tun hat, verbinden zu können. Als wir damit begonnen haben, die Ideen für dieses neue LEGO Technic Konzept zu sammeln, war uns klar, dass wir mehr als nur ein großartiges Bauerlebnis vermitteln wollten. Unser Konzept sollte etwas rundum Besonderes sein, um bei den Fans den Wunsch zu erwecken, das Modell zu besitzen und es zu bauen.“

„Wir wussten, dass wir dafür einen Partner mit dem perfekten Fahrzeug brauchten. Ein Fahrzeug, das Begehrlichkeit weckt und das Zeug zur Legende hat. Also haben wir Kontakt mit Porsche aufgenommen, denn es war unser Traum, den Porsche 911 zu unserem ersten Modell zu machen. Vom ersten Gespräch an war klar, dass Porsche dieselbe Leidenschaft für die Vision dieses Konzepts teilte. Wir haben dann gemeinsam beschlossen, den



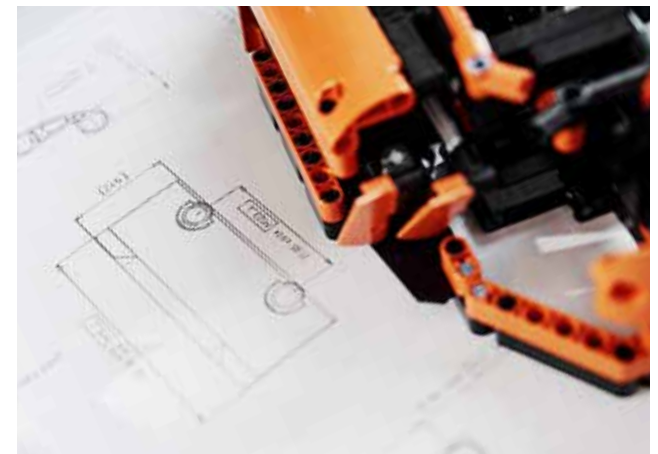

It's been fantastic working together with Porsche; the people we have met have shown a tremendous passion for the Porsche brand and a really deep interest in our LEGO Technic model.

ANDREW WOODMAN,
SENIOR DESIGN MANAGER, LEGO TECHNIC

Die Zusammenarbeit mit Porsche war fantastisch. Die Mitarbeiter, die wir getroffen haben, teilen eine unglaubliche Leidenschaft für die Marke Porsche und haben sich sehr für unser LEGO Technic Modell interessiert.

ANDREW WOODMAN,
SENIOR DESIGN MANAGER, LEGO TECHNIC



→ "Based only on images, we started the development of our first model. This was presented to the 911 GT3 RS design team at Porsche, who gave feedback on the important design features that define the iconic 911 shape.

"We developed the next model based on this feedback and also started the development of the wheels, which are an iconic part of the design of the car.

"About a month later we visited the 911 GT3 RS design team at the Porsche Development Center in Weissach. Here we presented our model to Andreas Preuninger, Head of GT Cars, and had a good discussion on the challenges of creating a 911 and specifically his team's 911 GT3 RS in LEGO elements. We had the opportunity to demonstrate all the technical features and got feedback on the functions Mr Preuninger wished to see in the model, and in which areas he felt the car's styling could be improved.

"Then we went to the Porsche GT workshop area to see a preproduction 911 GT3 RS complete and finished in lava orange. This was the first time we saw the car in colour – all the others had been black, which Porsche uses intentionally to make it difficult to see the proportions and details of the car."

neuesten 911 GT3 RS als erstes Fahrzeug dieser LEGO Technic Serie umzusetzen."

„Die Entwicklung unseres ersten Modells haben wir nur anhand von Bildern begonnen. Das Ergebnis davon haben wir dann dem Konstruktionsteam des 911 GT3 RS bei Porsche präsentiert, um die für den 911 elementaren Designmerkmale und die Karosserieform zu diskutieren.“

„Das nächste Modell haben wir auf der Grundlage dieser Rückmeldung entwickelt und parallel mit der Entwicklung der Räder begonnen, die ein wichtiger Teil des legendären Designs dieses Autos sind.“

„Etwa einen Monat später besuchten wir das Konstruktionsteam des 911 GT3 RS vor Ort im Porsche Entwicklungszentrum in Weissach. Wir präsentierten dem Gesamtprojektleiter GT-Straßenfahrzeuge Andreas Preuninger unser Modell und sprachen ausführlich über die Herausforderungen, den 911 – und speziell den 911 GT3 RS – aus LEGO Elementen zu konstruieren. Bei dieser Gelegenheit konnten wir all die technischen Eigenschaften des Modells zeigen. Mit Andreas Preuninger diskutierten wir, welche Funktionen übernommen werden sollten und wie wir elementare Designelemente des Modells verbessern konnten.“

„Beim Besuch des Porsche GT-Werkstattbereichs konnten wir einen Prototyp des 911 GT3 RS begutachten, der bereits fertiggestellt und in Lavaorange lackiert war. Das war das erste Mal, dass wir das Auto in Farbe sahen. Bis dahin haben wir es nur in Schwarz gesehen, was es viel schwieriger machte, die Proportionen und Details des Autos zu erkennen.“



The LEGO design team and Porsche 911 GT3 RS development team discuss the model at the Porsche Motorsport Center in Weissach. Das LEGO Design-Team und das Projekt-Team des Porsche 911 GT3 RS diskutieren das Modell im Porsche Motorsportzentrum in Weissach.

➊ "Back in Billund at LEGO Group HQ we started the development of the wing elements, as it became clear we needed a more defined outline to the wheel arch area of the car, both front and rear. This was one of our biggest challenges, as we needed to design an element to work on the 911 GT3 RS but also to be a LEGO Technic element that would work with all our other elements and be something that could work in our system for years to come.

"On returning from Porsche, the real hard work of the project began – the graphic designer started working on the required decorations and stickers, the model designer worked further on the styling using the new elements to great effect. This was an extremely difficult stage for the development of the gearbox and the designer went through many different versions before we ended up developing one last new element to make the gearbox run smoothly.

"The next big step was the final approval at Porsche. We got it. And after months of exciting work it was great to stand with such an accurate, function-filled model of one of the most iconic cars in the world – and to have it signed off by the designers and engineers of the real thing. A fantastic feeling all round." ✎

„Bei unserer Rückkehr in die Zentrale der LEGO Group in Billund begannen wir mit der Entwicklung der Kotflügel-Elemente. Es hatte sich herausgestellt, dass wir die Konturen der Radläufe vorn und hinten klarer herausarbeiten mussten. Eine der größten Herausforderungen für uns lag darin, ein Element zu kreieren, das sich sowohl für den 911 GT3 RS eignet, aber auch ganz allgemein mit allen weiteren LEGO Technic Elementen kompatibel und zudem für viele Jahre für unser System nutzbar ist.“

„Nach unserem Besuch bei Porsche stand uns die harte Arbeitsphase im Projekt bevor. Der Grafikdesigner begann mit dem Entwurf der benötigten Dekoelemente und Sticker, der Modelldesigner arbeitete weiter an der Fahrzeugform und setzte die neuen Elemente sehr wirkungsvoll ein. Es folgte die sehr schwierige Entwicklungsphase des Getriebes. Unser Designer hat zahlreiche Versionen verworfen, bis wir ein letztes neues Element entwickelt hatten, mit dem das Getriebe reibungslos funktioniert.“

„Der nächste große Schritt war die endgültige Abnahme durch Porsche. Und die haben wir erhalten. Nach all den Monaten spannender Arbeit war es einfach großartig, ein so präzises, mit so vielen Funktionen ausgestattetes Modell eines der legendärsten Autos der Welt in den Händen zu halten – und das in dem Wissen, dass es von den Konstrukteuren und Ingenieuren des echten Wagens für gut befunden wurde. Ein durch und durch fantastisches Gefühl.“ ✎



Meetings with potential partners and development of preliminary sketch models.

Treffen mit möglichen Partnern und Entwicklung der vorläufigen Skizzenmodelle.

Start of design and prototyping of Porsche wheels.

Designstart und Prototypenerstellung der Porsche Felgen.

LEGO TECHNIC



Spring
Frühling
2014



Autumn
Herbst
2014

Winter
Winter
2013



Development of the initial ideas around the concept.

Entwicklung erster Gestaltungsideen rund um das Konzept.

Summer
Sommer
2014



First presentation of a very early model for Porsche in Stuttgart.

Erste Präsentation eines Prototypen-Modells bei Porsche in Stuttgart.

Winter
Winter
2014



First top-secret images of the 911 GT3 RS shared by Porsche.

Porsche stellt die ersten streng geheimen Bilder des 911 GT3 RS zur Verfügung.

First sketch model images delivered to Porsche for feedback.

Erste Bilder der Skizzenmodelle werden zur Beurteilung an Porsche geliefert.



Winter
Winter
2014

Development of new styling elements started including graphics, decorations, laser engraving and stickers.

Start der Entwicklung neuer Gestaltungselemente, einschließlich Grafiken, Dekoelementen, Lasergravuren und Stickern.



Spring
Frühling
2015

Meeting with Andreas Preuninger and his team for final approval of model.

Treffen mit Andreas Preuninger und seinem Team zur Endabnahme des Modells.



Autumn
Herbst
2015

Spring
Frühling
2015



First meeting with Andreas Preuninger and his team at the Porsche Development Center.

Erstes Treffen mit Andreas Preuninger und seinem Team im Porsche Entwicklungszentrum.

Summer
Sommer
2015



Building, testing and re-building of the model with LEGO model quality team and building instructions designers.

Bauen, Testen und Umbauen des Modells durch das LEGO Team für Modellqualität und die Spezialisten für Bauanleitungen.





Senior LEGO Designer Uwe Wabra.



A Passion for Detail

A quick look at Senior LEGO Designer Uwe Wabra's own garage clearly shows that this is someone who is into anything mechanical that can be taken apart and assembled again. Cars, motorbikes, mopeds, bicycles – pretty much everything that is mechanical and on wheels. Mix his hobbies with his 19 years of experience as a LEGO product designer, and it's easy to see why the Porsche 911 GT3 RS project landed on his desk in the LEGO Technic designer team.

"It was fantastic to get the opportunity to work on the Porsche project, but also a real challenge. As Porsche's 911 GT3 RS project was still top secret at the time, I had to build the first Technic version from 'spy-photos' from the Internet.

"I did the first prototype in a matter of weeks. We then took it to Porsche and got great feedback from the 911 GT3 RS team on both the technical details and the overall design.

Mit Liebe zum Detail

Der Blick in die Garage von Senior LEGO Designer Uwe Wabra verrät sofort, dass sie jemandem gehört, der ein großer Fan von allem ist, das sich auseinandernehmen und wieder zusammensetzen lässt. Ob es nun Autos, Motorräder, Mopeds oder Fahrräder sind, es muss nur mechanisch sein und Räder haben.

In Anbetracht dieser Hobbys und seines 19-jährigen Erfahrungsschatzes als LEGO Produktdesigner ist es nur allzu verständlich, dass das Projekt für den Porsche 911 GT3 RS auf seinem Schreibtisch im LEGO Technic Designer-Team landete.

„Es war unglaublich, die Möglichkeit zu erhalten, am Porsche-Projekt zu arbeiten, aber auch eine echte Herausforderung. Das 911 GT3 RS Projekt von Porsche war zu diesem Zeitpunkt noch streng geheim, daher musste ich die erste Technic-Version mithilfe von ‚Spionagefotos‘ aus dem Internet bauen.“

- ➔ That's also when I saw the real 911 GT3 RS for the first time. I was very inspired by its minimalistic, brutal design and left Stuttgart even more eager to take our model to the next level.

"I really wanted to incorporate as many of the unique design details from the real car as possible, especially the shape of the bonnet and roof, the air-intakes and not least the low, sloping angle of the car.

"It was also important to integrate as many of the advanced technical functionalities from the real 911 GT3 RS as we could. The steering and suspension were difficult enough, but the biggest challenge was to create the functioning paddle-shift PDK gearing system.

"I am really proud of the finished model – it's great that we managed to give the LEGO Technic model the genuine 911 silhouette design-line and add so many advanced technical features." ✖

„Der erste Prototyp war in wenigen Wochen fertig. Wir haben ihn dann Porsche gezeigt und eine super Rückmeldung vom 911 GT3 RS Team bezüglich technischer Details und des Designs insgesamt erhalten.

Das war dann auch meine erste Begegnung mit dem echten 911 GT3 RS. Sein minimalistisches, kompromissloses Design hat mich sehr inspiriert, und ich verließ Stuttgart mit noch mehr Vorfreude darauf, unser Modell zu verfeinern.“

„Es ging mir darum, so viele der einzigartigen Designmerkmale des echten Autos wie möglich einzuarbeiten, ganz besonders die Form von Kofferraumdeckel und Dach, die Lufteinlässe und nicht zuletzt die niedrige, abfallende Linienführung.“

„Es war auch wichtig, so viele der hochentwickelten technischen Funktionen des echten 911 GT3 RS zu integrieren, wie wir konnten. Die Lenkung und Aufhängung waren schwierig genug, aber die größte Herausforderung war das Porsche Doppelkupplungsgetriebe (PDK) mit Schaltpaddles.“

„Ich bin sehr stolz auf das fertige Modell – es ist großartig, dass wir es geschafft haben, dem LEGO Technic Modell die Originalform des 911 zu verleihen und so viele anspruchsvolle technische Funktionen einzubauen.“ ✖

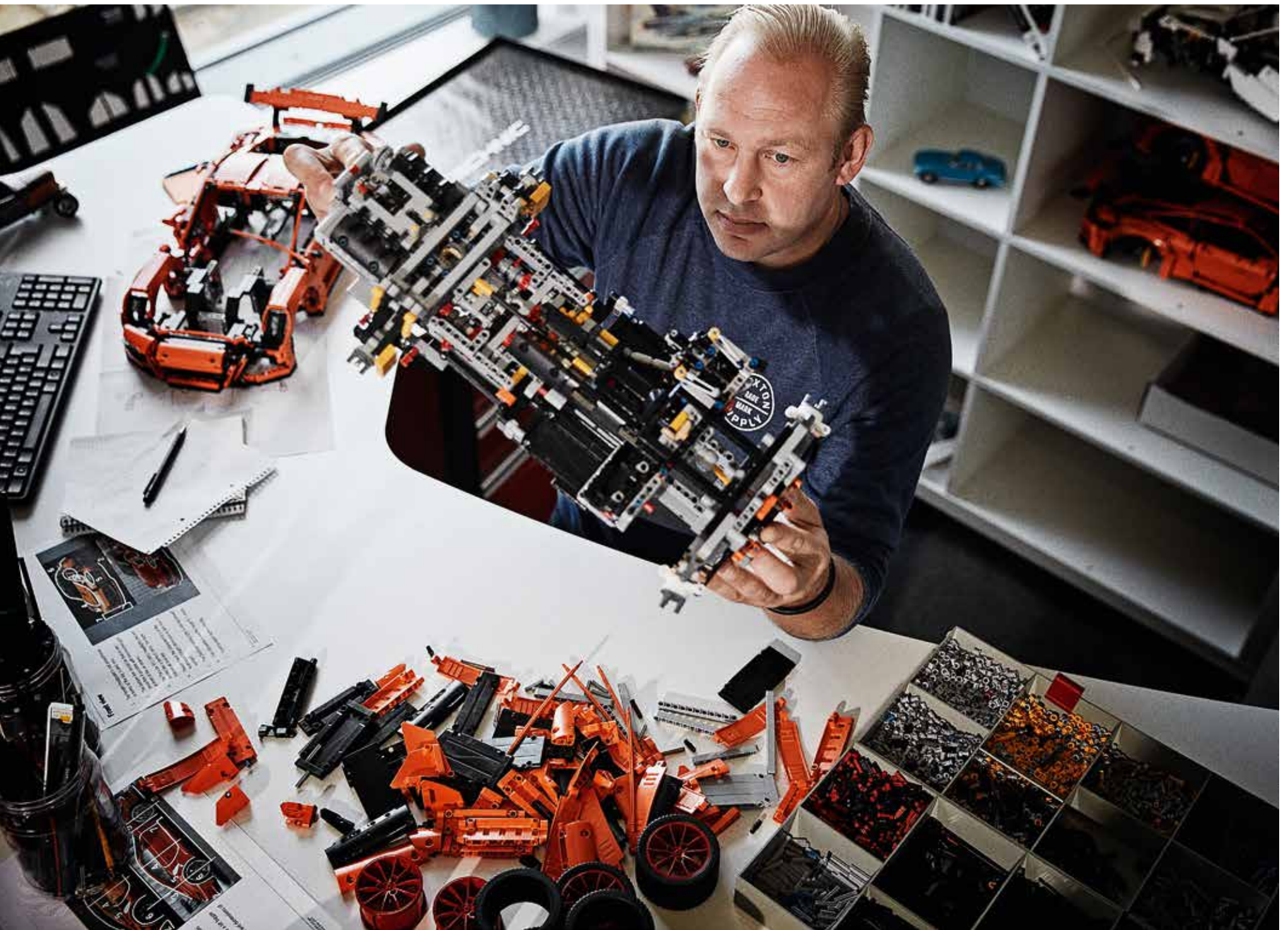



Dr. Frank-Steffen Walliser, VP Motorsports and GT Cars at Porsche with his first LEGO Technic model from 1980.

Dr. Frank-Steffen Walliser, Leiter Motorsport und GT-Fahrzeuge bei Porsche, mit seinem ersten LEGO Technic Modell von 1980.

A LEGO® Memory

"This is *exactly* the one," is the immediate comment from Dr. Frank-Steffen Walliser, VP Motorsports and GT Cars at Porsche. Just returned from a victorious Porsche race weekend in the US, Dr. Walliser is pointing at an early LEGO Technic model launched in 1980 that's placed on his desk in his office.

"LEGO was a big part of my childhood. I had several LEGO models and I think I got this specific one as a Christmas present when I was about 11 years old. I still remember all its details and technical features," says Dr. Walliser, while proving his LEGO knowledge by discretely pointing out that one of the wheels on the model has been mounted the wrong way round.

"I actually made a small mistake when assembling the boxer engine. I couldn't make the pistons work properly even though I took the model apart and assembled it over and over again. My friend had the same model and his worked perfectly fine so I knew it could and should work smoothly. It nagged me for months until I got hold of the model again and finally made it work as it was supposed to.

"This LEGO Technic model was part of defining my interest in cars and later, as a teenager, helped push my education and career in the direction of technical engineering."

Eine LEGO® Erinnerung

„Von *genau* dem habe ich gesprochen“, so die spontane Reaktion von Dr. Frank-Steffen Walliser, Leiter Motorsport und GT-Fahrzeuge bei Porsche. Soeben von einem für Porsche siegreichen Rennwochenende in den USA zurückgekehrt, deutet Dr. Walliser auf ein frühes LEGO Technic Modell aus den 80er Jahren, das auf seinem Schreibtisch steht.

„LEGO war ein wichtiger Teil meiner Kindheit. Ich besaß mehrere LEGO Modelle, und ich glaube, dieses hier habe ich zu Weihnachten bekommen, als ich ungefähr 11 Jahre alt war. Ich kann mich immer noch an alle Details und technischen Funktionen erinnern“, meint Dr. Walliser, und untermauert sein LEGO Wissen mit dem dezenten Hinweis, dass eines der Räder am Modell falsch herum montiert wurde.

„Beim Zusammenbau des Boxermotors ist mir damals ein Fehler unterlaufen. Die Kolben funktionierten nicht richtig. Und das obwohl ich das Modell immer wieder auseinandergenommen und zusammengebaut habe. Ein Freund von mir hatte das gleiche Modell, und da bei ihm alles einwandfrei funktionierte, wusste ich, dass es bei meinem auch möglich sein musste. Das hat mich monatelang beschäftigt, bis ich es endlich richtig zum Laufen gebracht habe.“

„Dieses LEGO Technic Modell hat viel zu meinem Interesse für Autos beigetragen, sodass ich mich später als Teenager für eine Ausbildung und berufliche Laufbahn in der Ingenieurtechnik entschieden habe.“ ➔

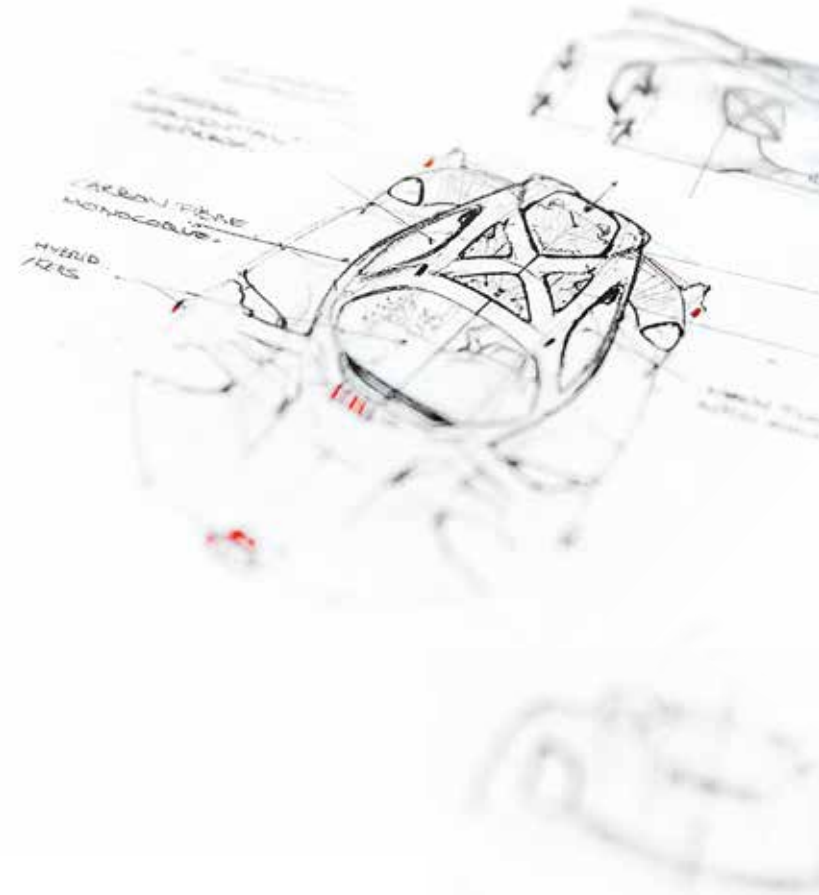

- "I am glad to see how my own kids have picked up on LEGO and LEGO Technic. My son got his first Technic set around the age of six. He is completely into it and I like the fact that it helps his understanding of how things function mechanically.

"We have a standard procedure when the kids and I begin building a new LEGO set. We sit down, closely study the box and the building instructions, and then we start sorting the bricks by colour, form and function. After that we start the actual building. For us the building of the model is play in itself.

"Looking at the LEGO Technic Porsche 911 GT3 RS model, I'm impressed that they have managed to create the distinct curved lines of the Porsche 911. I know how difficult it is to shape the softer lines with LEGO elements.

"It is great to experience the level of detail and all the working parts in the model. The functioning PDK gear is especially impressive. And I like that everything is there, even if it is eventually hidden away – just like in the real car.

"At Porsche, a car is not just a car: it's all about the design, the performance, the sense of detail and, not least, the passion and dedication. I really feel that those things are here when you look at the LEGO model." ✖

„Umso mehr freut es mich, dass meine Kinder LEGO und LEGO Technic ebenso lieben. Mein Sohn hat sein erstes Technic-Set mit etwa sechs Jahren bekommen. Er spielt sehr gern damit, und mir gefällt daran, dass sein Verständnis für mechanische Funktionsweisen dadurch gefördert wird.“

„Meine Kinder und ich gehen immer gleich vor, wenn wir mit einem neuen LEGO Set anfangen. Wir setzen uns zusammen, sehen uns den Karton und die Bauanleitung genau an, und sortieren die Steine nach Farbe, Form und Funktion. Erst danach legen wir mit dem Bauen los. Für uns ist gerade das Zusammenbauen das eigentliche Spielen mit dem Modell.“

„Wenn ich mir das Porsche 911 GT3 RS Modell von LEGO Technic ansehe, beeindruckt mich vor allem die gelungene unverwechselbare Formgebung des Porsche 911. Ich weiß, wie schwierig es ist, geschwungene Linien mit LEGO Elementen nachzubauen.“

„Diese Detailtreue und die funktionierenden Teile sind einfach großartig. Besonders beeindruckend ist das funktionstüchtige Porsche Doppelkupplungsgetriebe. Und mir gefällt, dass alles vorhanden ist, selbst wenn es nicht unbedingt sichtbar ist – genau wie im richtigen Auto.“

„Bei Porsche ist ein Auto nicht nur ein Auto: Es dreht sich alles um das Design, die Leistung, den Sinn fürs Detail – und letztlich auch um Leidenschaft und Hingabe. Ich finde, all das kann man spüren, wenn man sich das LEGO Modell ansieht.“ ✖

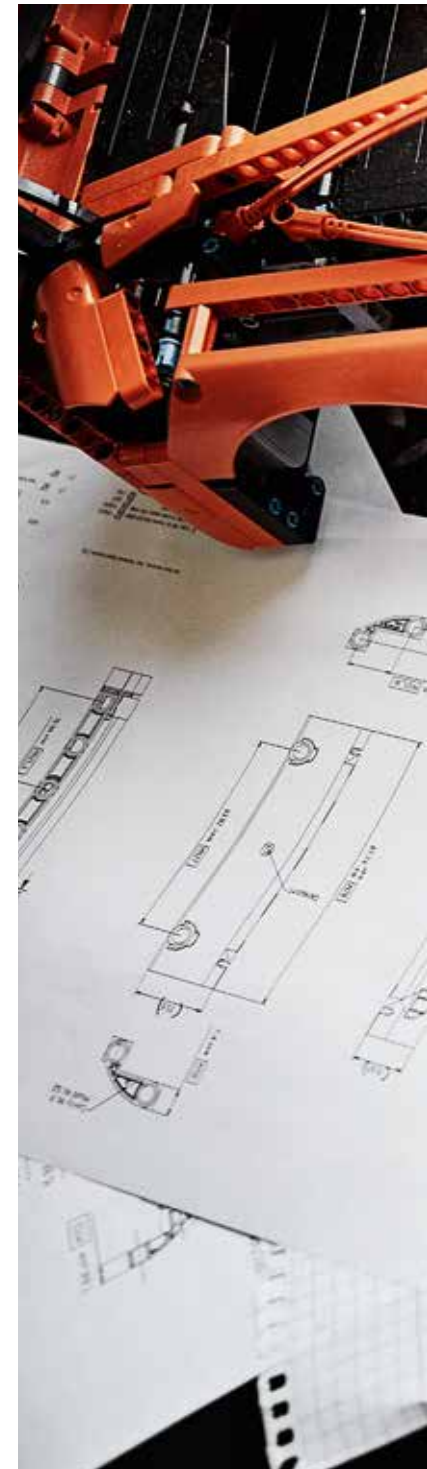





Wolfgang Reiß, Plant Manager, Porsche.
Wolfgang Reiß, Werkleiter, Porsche.



Producing Excellence

With more than 25 years of experience at Porsche, and the last three years as Plant Manager, Wolfgang Reiß is the most knowledgeable person to explain the challenges of constructing a car like the Porsche 911 GT3 RS.

"It's a special car and it takes a number of unique processes to ensure that the 2700 larger individual elements that go into the 911 GT3 RS come precisely together," says Mr Reiß. He explains that it takes four full days to assemble a Porsche 911 GT3 RS on the production line at the factory in Stuttgart and that the car will pass through the skilled hands of more than 600 specialists as it is assembled.

Produktion in höchster Qualität

Mit einer Unternehmenszugehörigkeit von 25 Jahren, die letzten drei davon als Werkleiter, ist Wolfgang Reiß ein äußerst kompetenter Ansprechpartner, um die Herausforderungen bei der Konstruktion eines Autos wie dem Porsche 911 GT3 RS zu erläutern.

„Es ist ein besonderes Auto. Und es bedarf einer Reihe spezifischer Schritte, die sicherstellen, dass die 2700 größeren Einzelkomponenten des 911 GT3 RS präzise zusammengefügt werden“, so Wolfgang Reiß. Er führt weiter aus, dass die Endmontage eines Porsche 911 GT3 RS auf der Produktionslinie des Werks in Stuttgart vier Tage sowie verschiedene Arbeitsschritte von über 600 Spezialisten in Anspruch nimmt.

Auf die Frage nach den Besonderheiten bei der Konstruktion des 911 GT3 RS nennt Wolfgang Reiß den Frontdeckel, den Heckspoiler und vor allem die ➔

Asked to describe the specific issues they have with the 911 GT3 RS construction process, Mr Reiß highlights the luggage compartment lid, spoiler and especially the fenders as unique for this model, and the rollover bar as an option.

"Normally the complete body of the car is assembled with fenders for spraying. With the 911 GT3 RS the special fenders, with their integrated outlets, are not fitted to the body during the paint shop. This gives us a special challenge later when trying to ensure a uniform gap between the door and fender.

"The so-called 'marriage' is the magic moment in the Porsche production process. It's where the heart of the car – the engine – is mounted to rest on the drivetrain and the body is lowered for final assembly. It's a piece of logistic excellence to have these central components meet and merge at one spot on the assembly line within a matter of seconds."

Asked for his reaction on seeing the LEGO Technic version of the 911 GT3 RS for the first time, Mr Reiß states, "It's clear our two companies share the same dedication to detail. It's exciting to see how far LEGO has developed since my brother and I built simple cars with LEGO when we were young boys over 40 years ago." 🚗

Kotflügel, die für dieses Modell einzigartig sind. Zudem verweist er auf den Überrollbügel, welcher optional angeboten wird.

„Normalerweise wird die Karosserie komplett mit montierten Kotflügeln zur Lackierung vorbereitet. Der 911 GT3 RS hat aber spezielle Kotflügel mit integrierten Luftauslässen, die nicht während der Lackierung an die Karosserie montiert werden. Die besondere Herausforderung ist dabei, für ein gleichmäßiges Spaltmaß zwischen Tür und Kotflügel zu sorgen.“

„Der magische Moment im Produktionsprozess ist die sogenannte ‚Hochzeit‘, wenn das Herz des Fahrzeugs – der Motor – mit der Karosserie verbunden wird. Es ist eine logistische Meisterleistung, diese grundlegenden Komponenten innerhalb weniger Sekunden an einem Punkt der Montagelinie aufeinandertreffen zu lassen und zusammenzuführen.“

Auf seine Reaktion beim ersten Anblick der LEGO Technic Version des 911 GT3 RS angesprochen, sagt Wolfgang Reiß: „Ganz eindeutig teilen unsere beiden Firmen dieselbe Liebe zum Detail. Es ist spannend zu sehen, wie sich LEGO weiterentwickelt hat, seit mein Bruder und ich als Kinder vor mehr als 40 Jahren einfache Autos mit LEGO gebaut haben.“ 🚗





Get Ready To Build

Having read all about this special car and learned how LEGO designers work, it is now time to build your LEGO Technic version of the Porsche 911 GT3 RS. We hope you will enjoy the challenge...

Vorfreude auf den großen Bauspaß!

Nach den umfassenden Informationen über diesen einzigartigen Sportwagen und die Arbeit der LEGO Designer ist es jetzt an der Zeit, deine LEGO Technic Version des Porsche 911 GT3 RS zu bauen. Wir wünschen dir viel Spaß bei dieser Herausforderung...





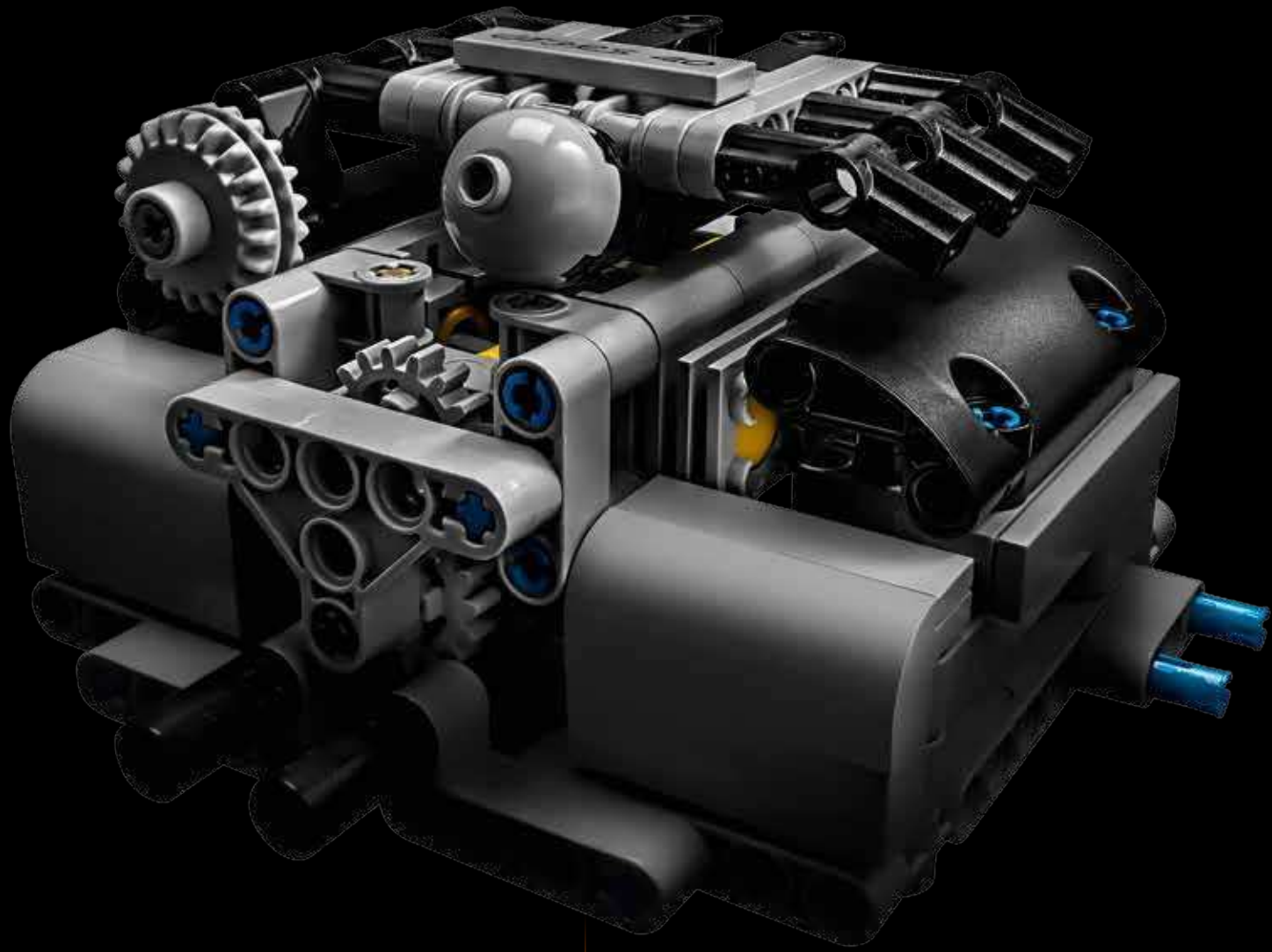

1

The first step in the construction of your 911 GT3 RS is to build the drivetrain, complete with dual clutch gearbox (PDK), paddle shifters, suspension and the heart of the 911 GT3 RS, the 4.0 flat 6 engine. When you have completed all the steps in box 1 you will be able to test out all the functions and see how they work.

Der erste Schritt bei der Konstruktion deines 911 GT3 RS ist der Zusammenbau des Antriebsstrangs, einschließlich des Porsche Doppelkupplungsgetriebes (PDK), der Schaltpaddles, der Aufhängung und des Herzstücks des 911 GT3 RS: dem 4,0-Liter-6-Zylinder-Boxermotor. Wenn du alle Schritte aus Box 1 ausgeführt hast, kannst du die Technik ausprobieren und sehen, wie sie funktioniert.

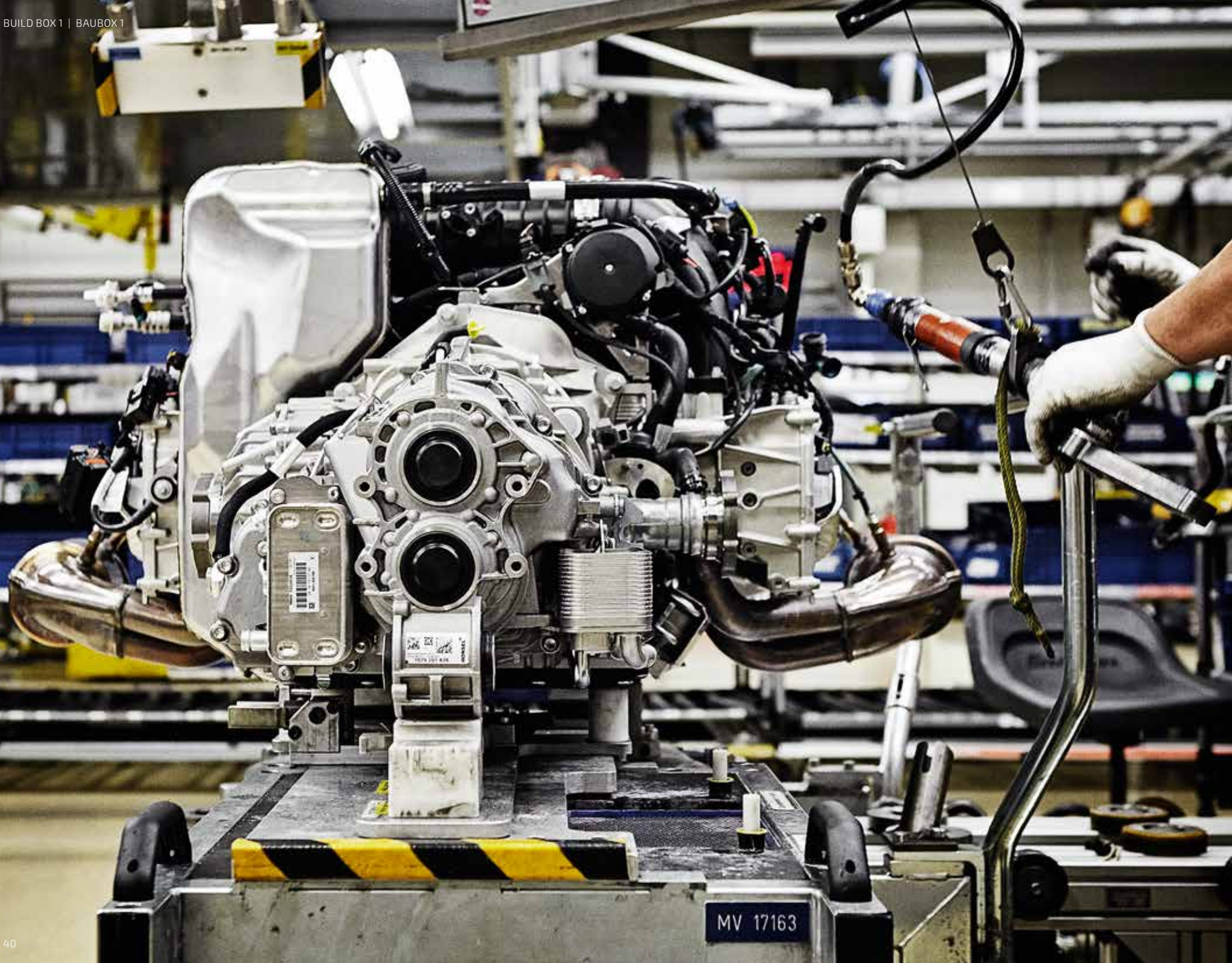

MV 17163

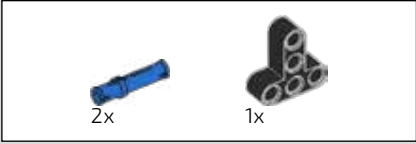

1

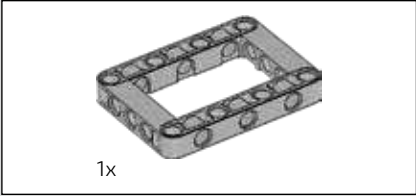
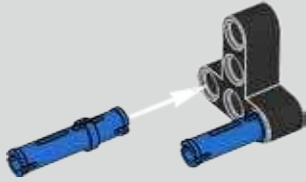

2

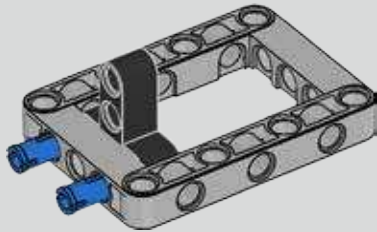

3

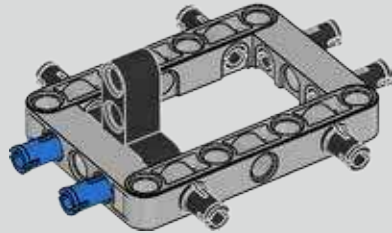

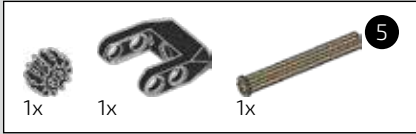

4

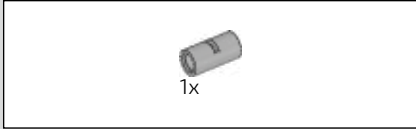
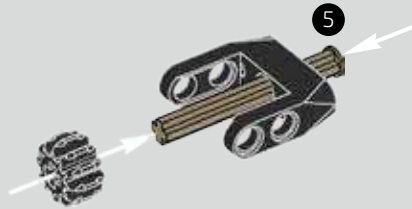

5

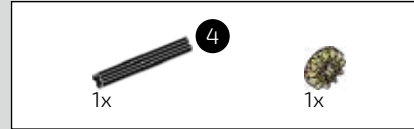
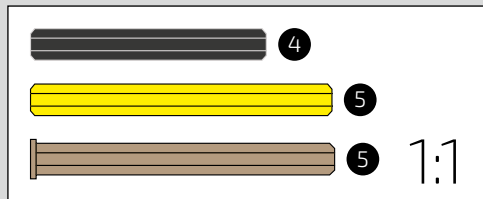

6

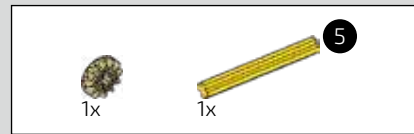

7

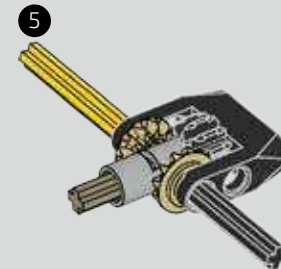

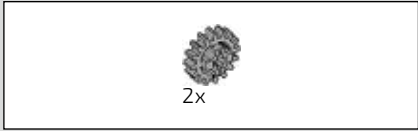

8

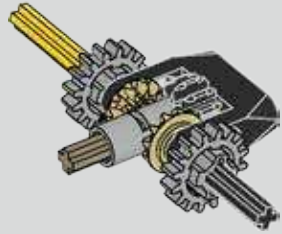

9

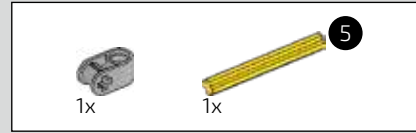
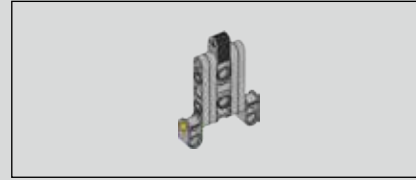
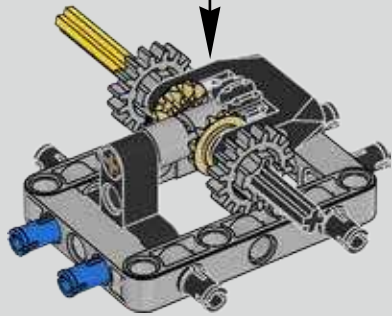

10

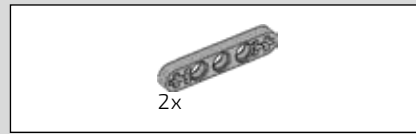
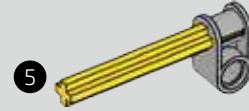

11

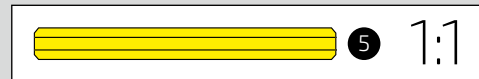
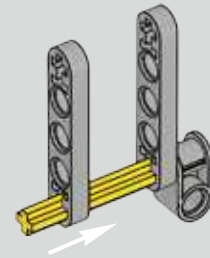

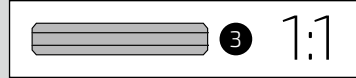
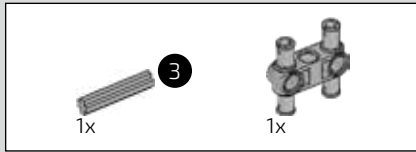

12

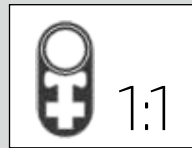
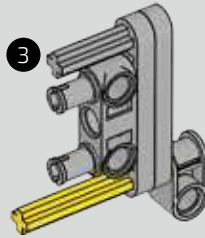

13

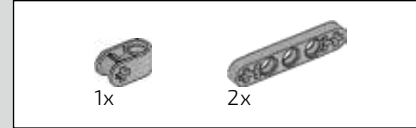
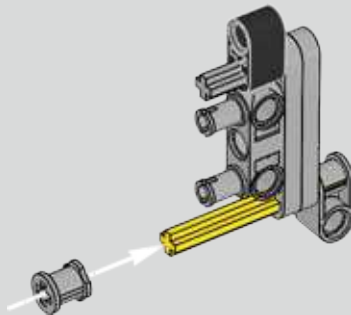

14

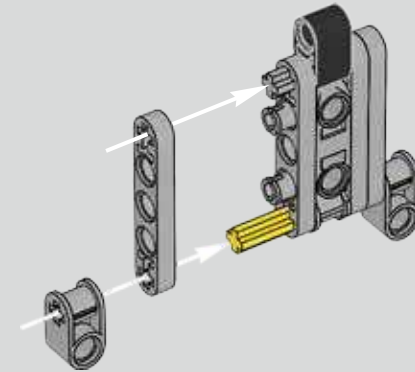

15

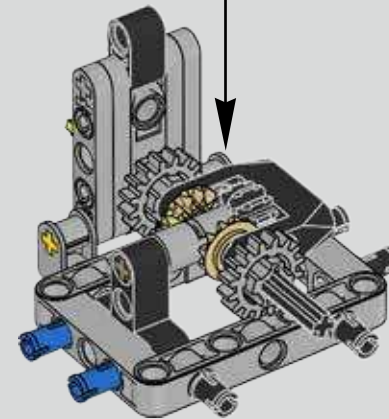



16

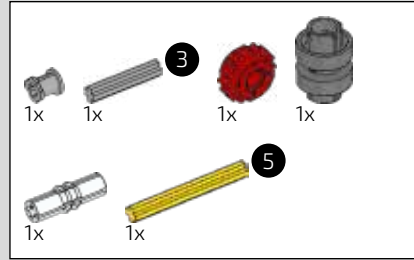
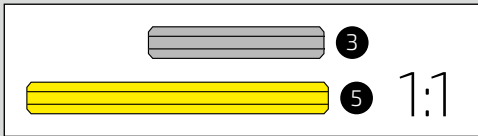
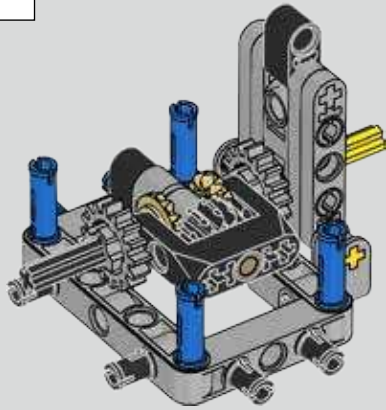
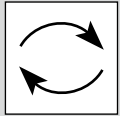

17

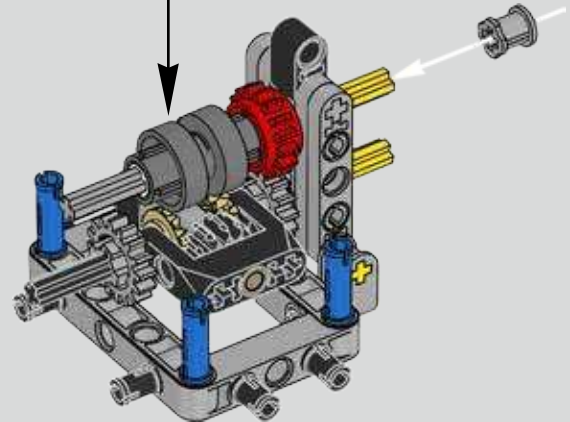
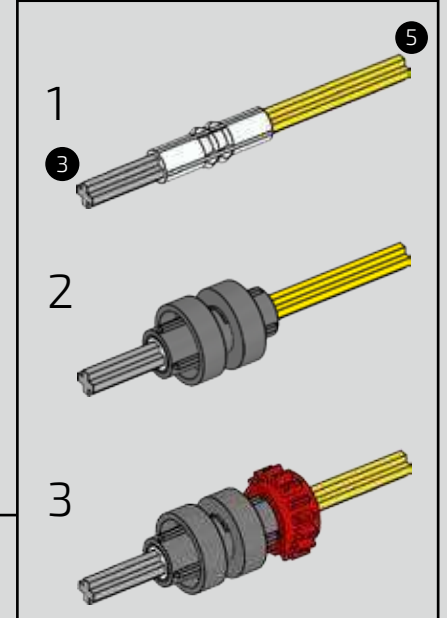

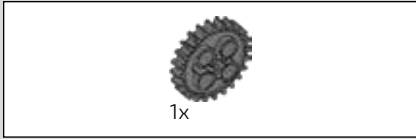

18

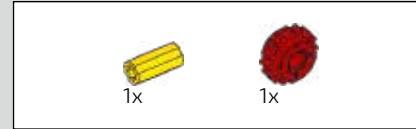
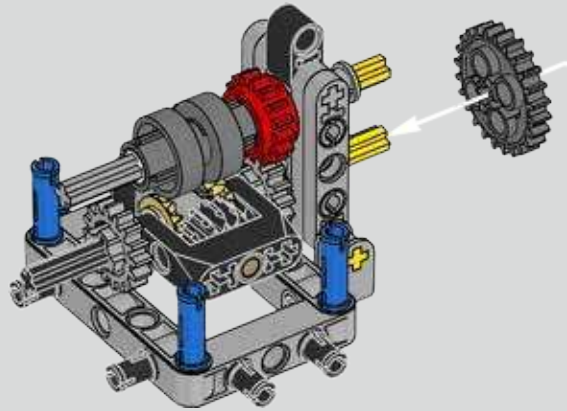

19

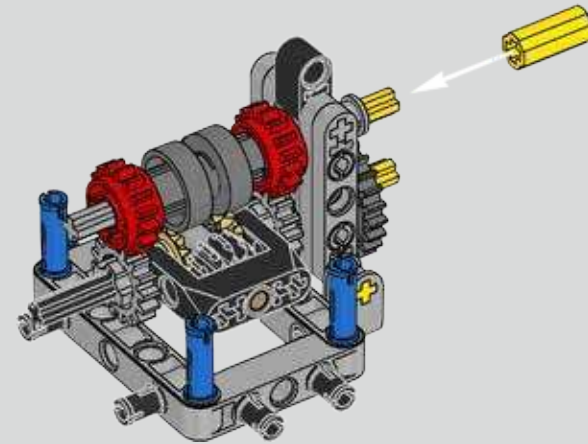

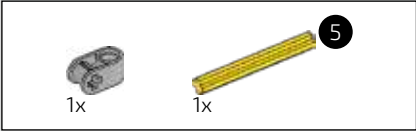
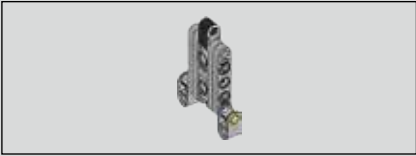

20

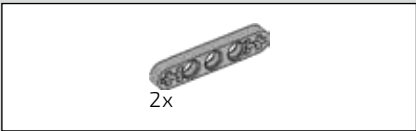
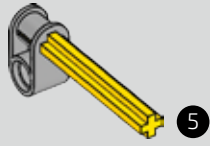

21

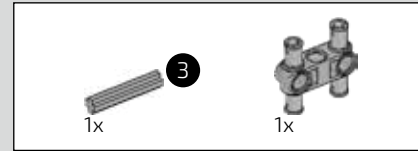
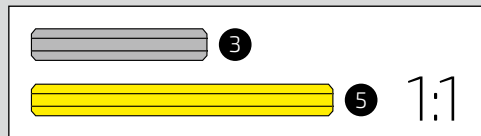
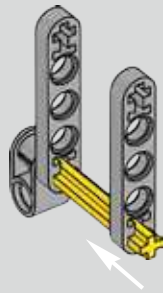

22

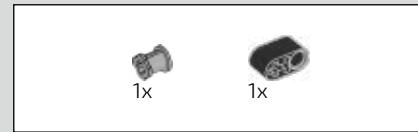
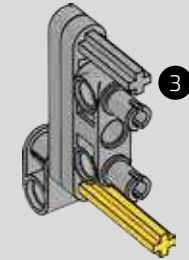

23

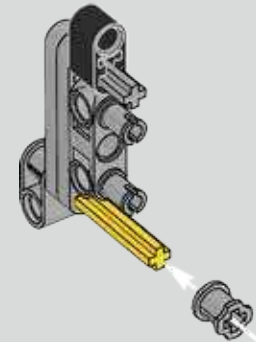



24

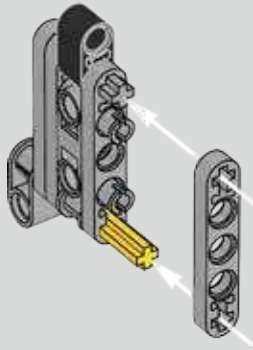

25

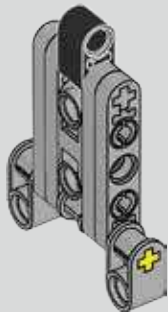

26

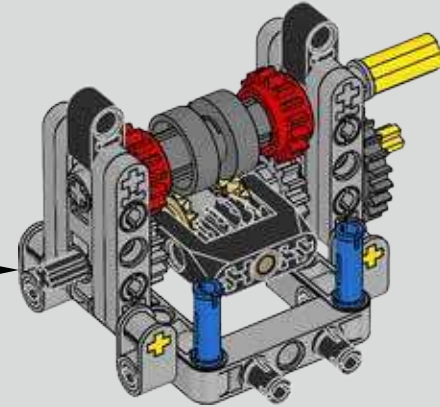

27

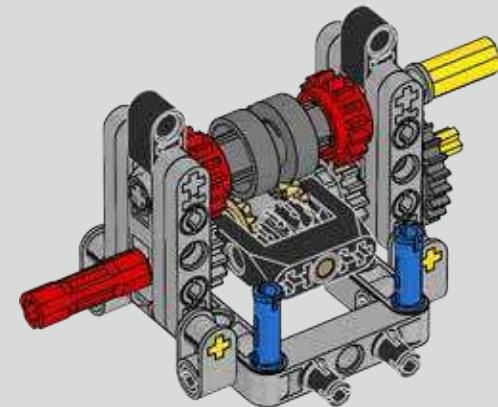

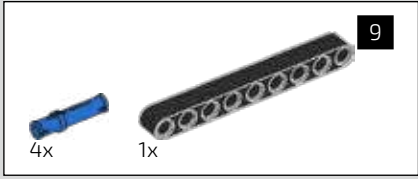

28

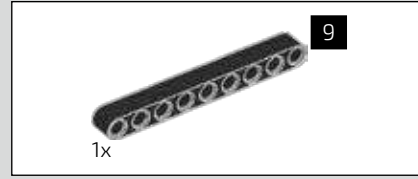
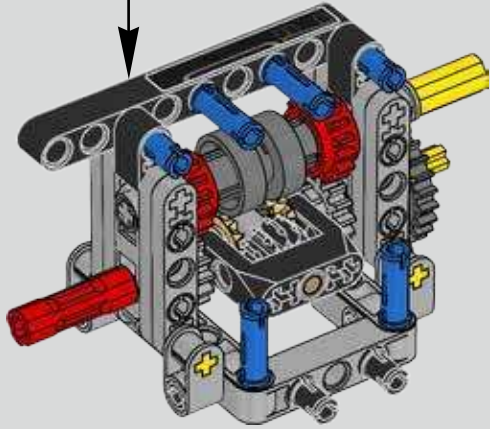
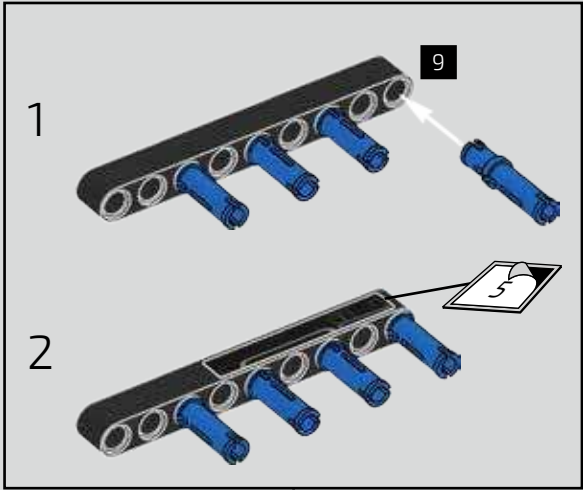

29

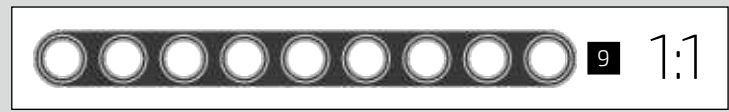
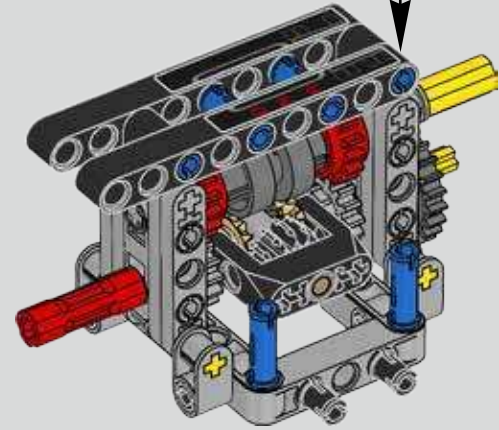
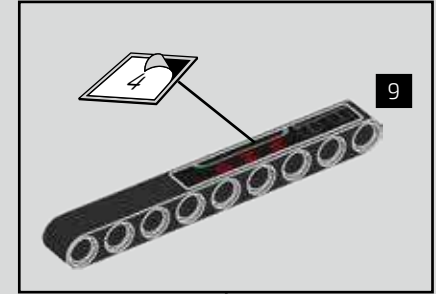

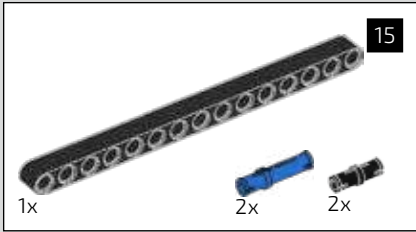
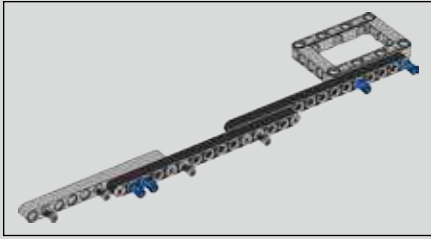

30

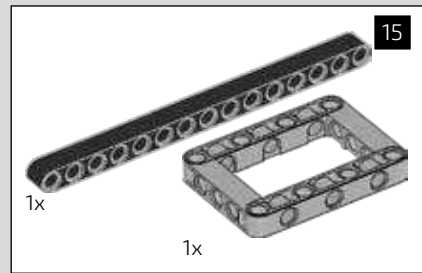
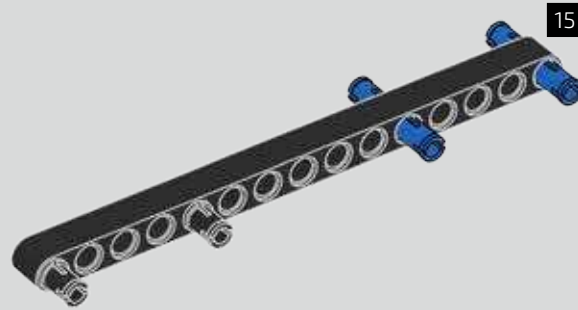

31

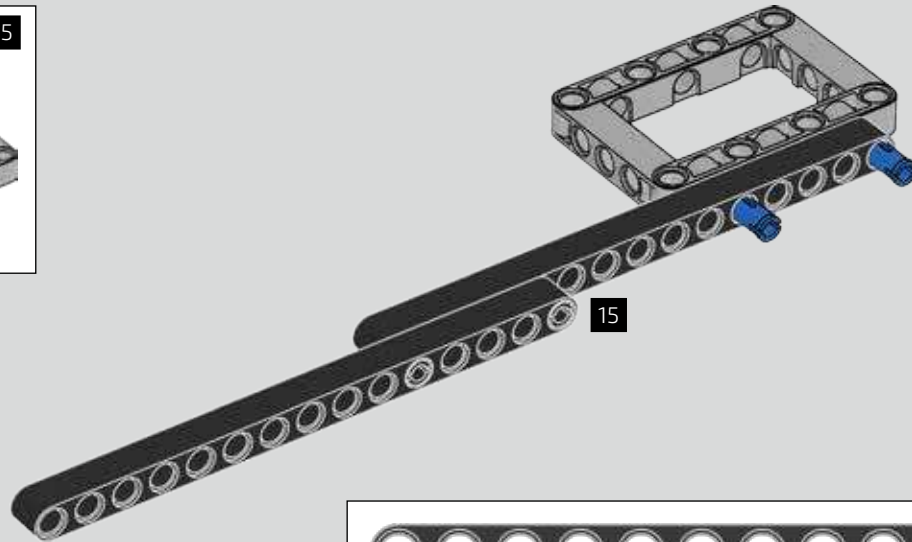



32

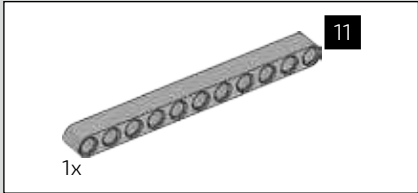
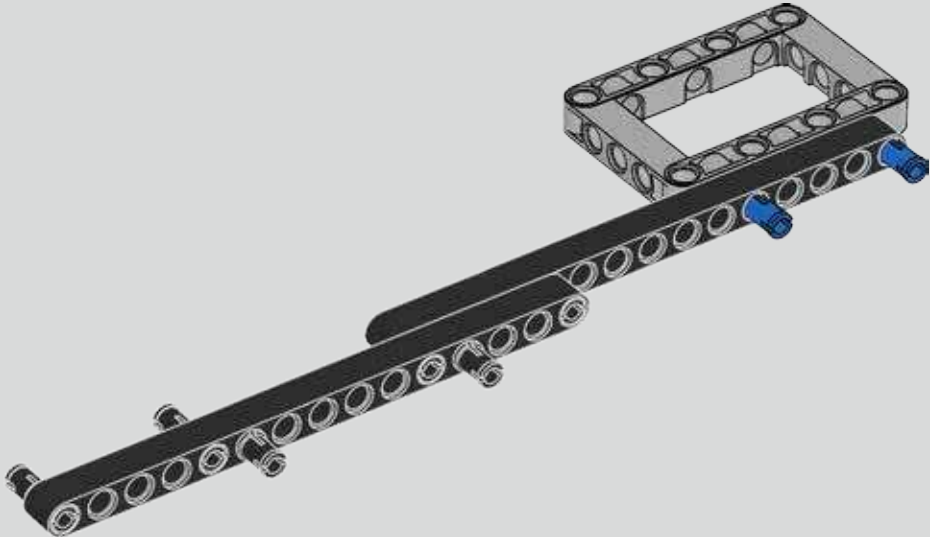

33

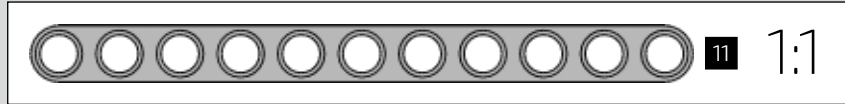
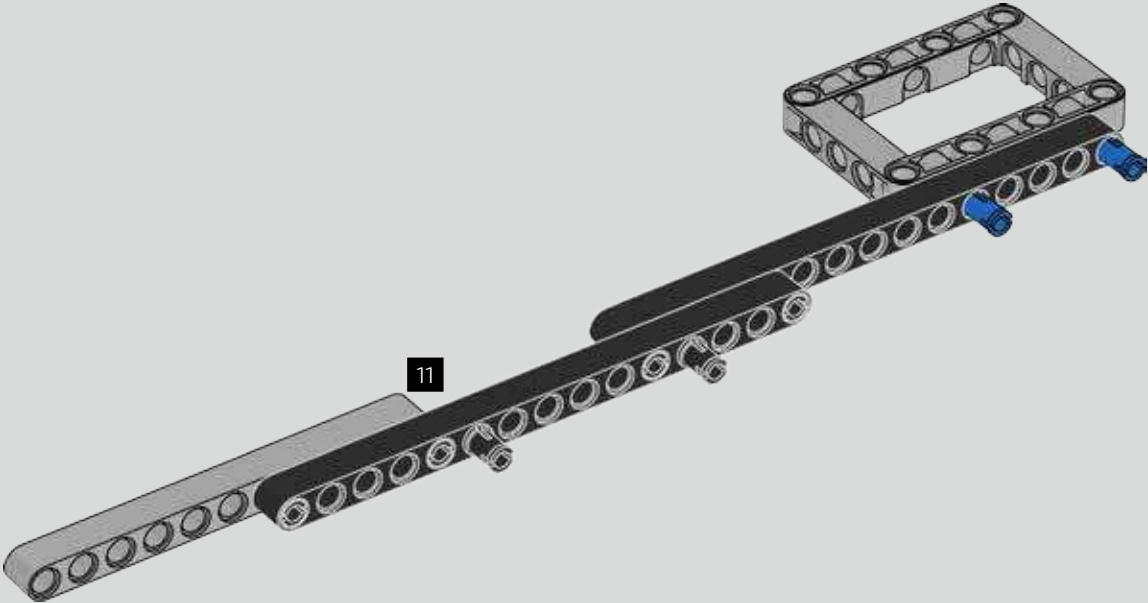

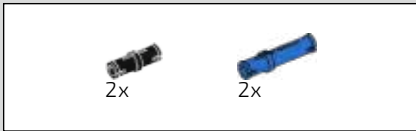

34

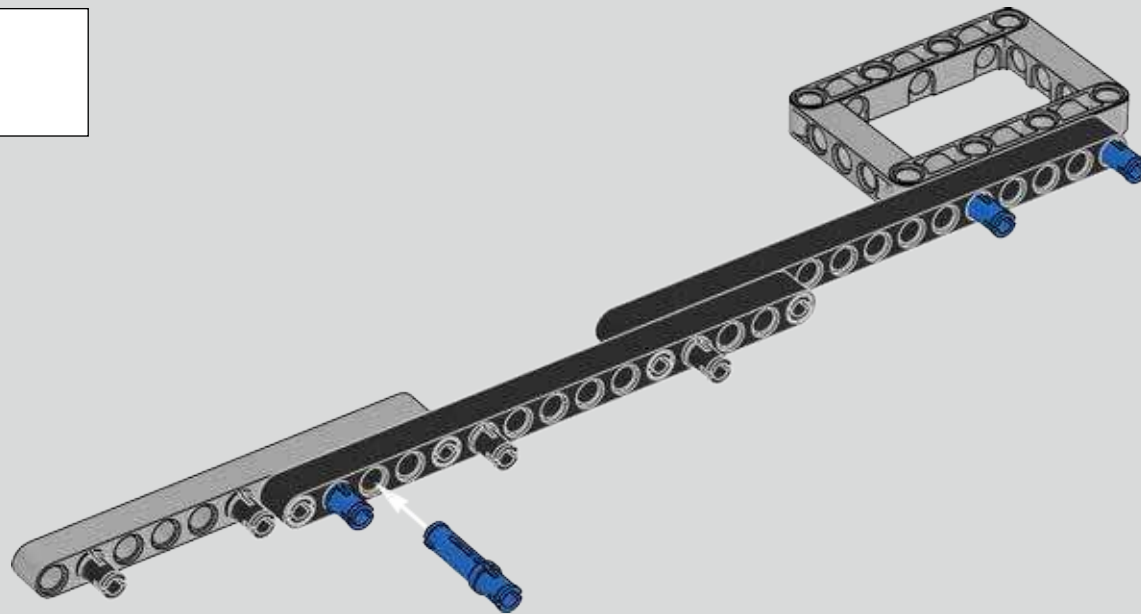

35

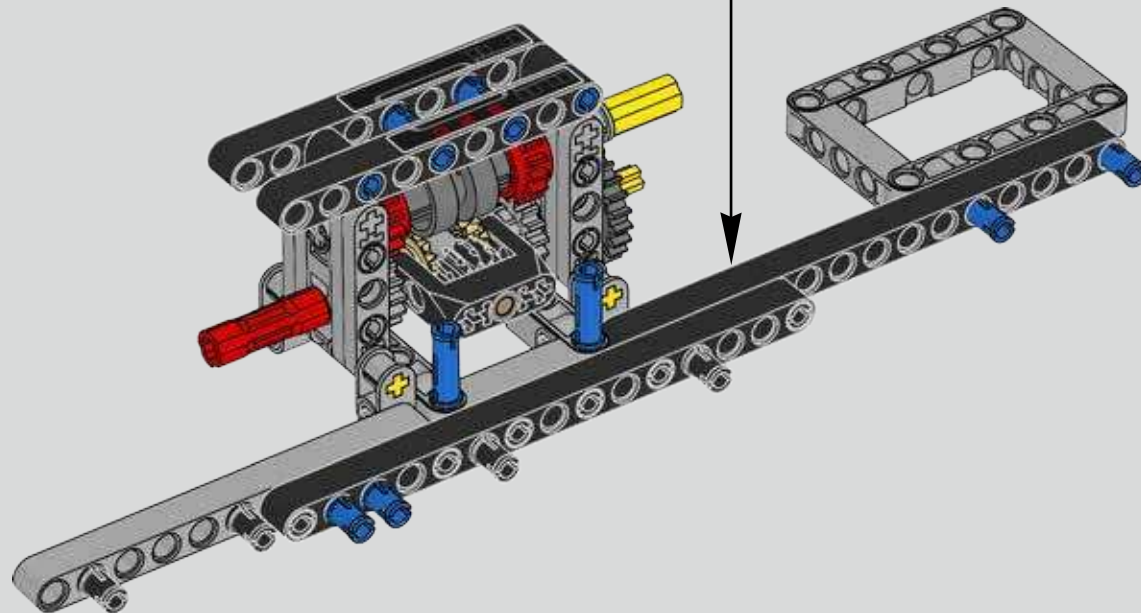

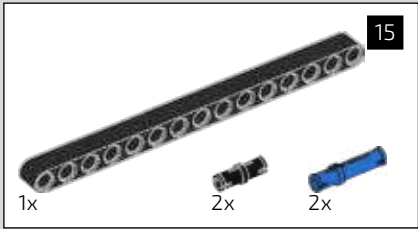
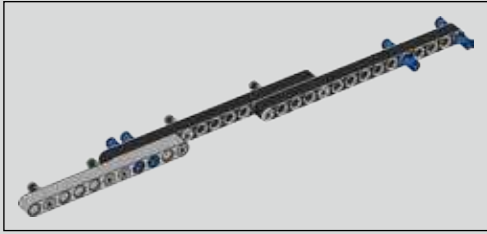

36

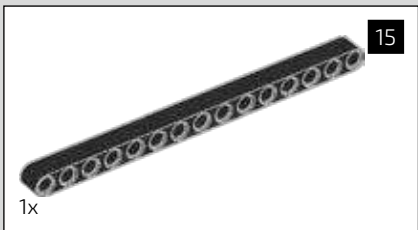
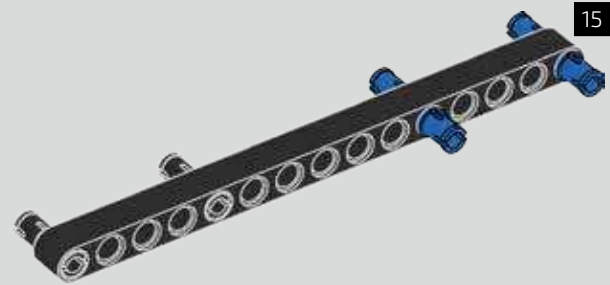

37

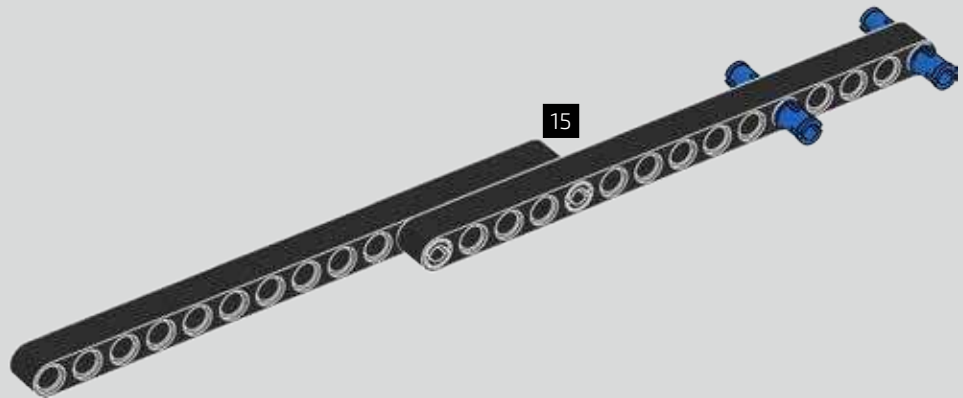



38

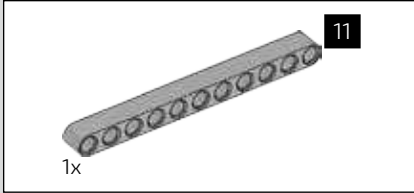
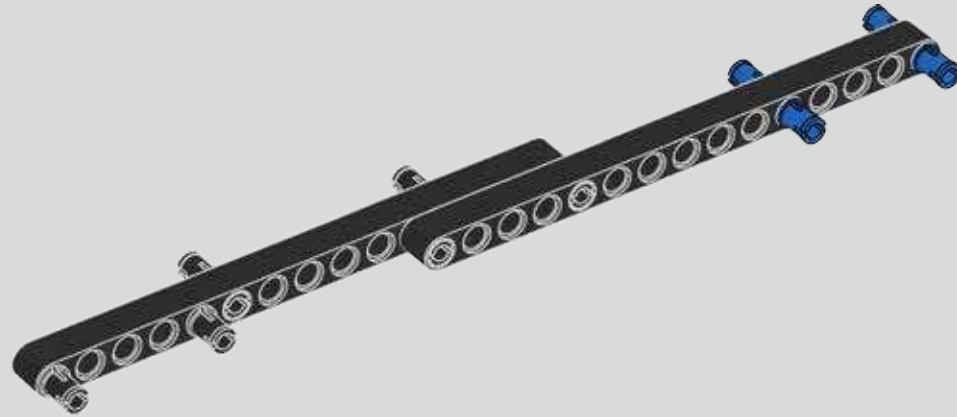

39

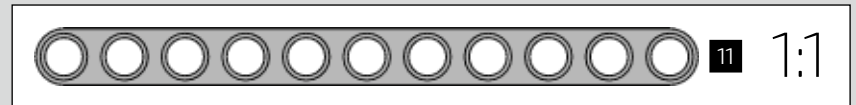
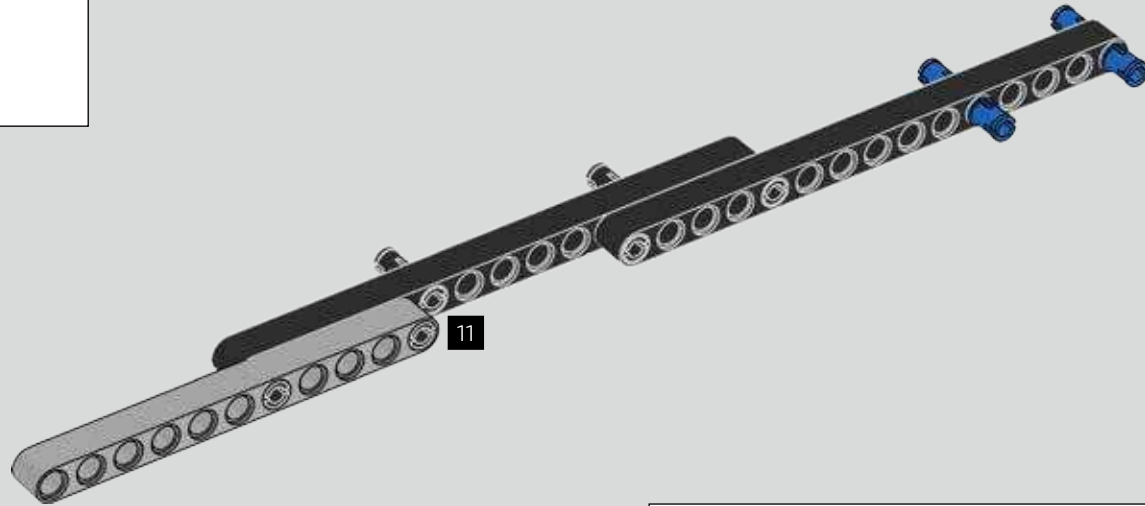

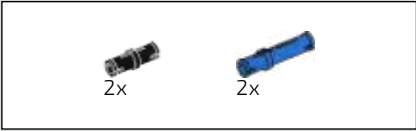

40

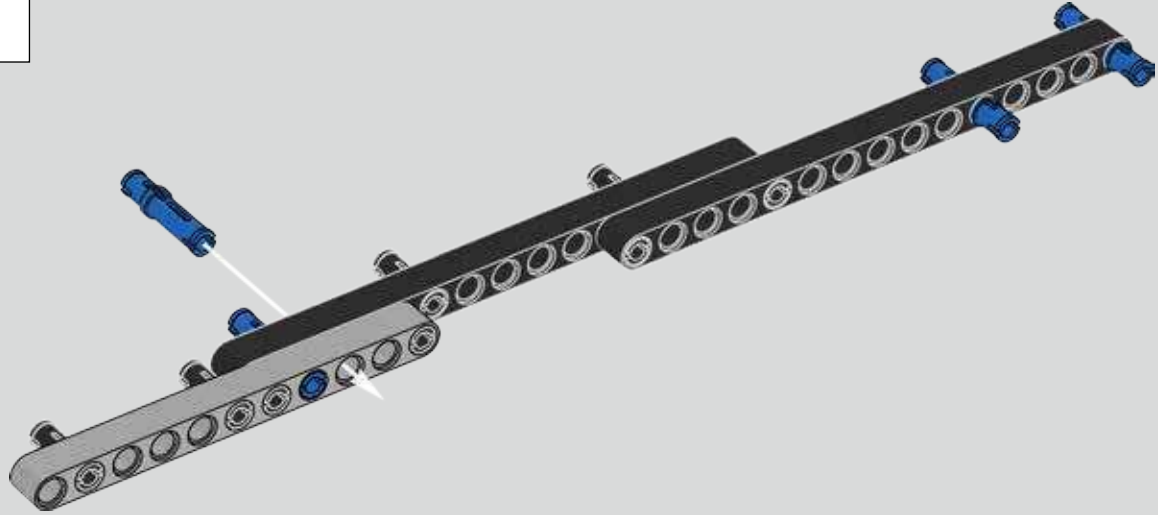

41

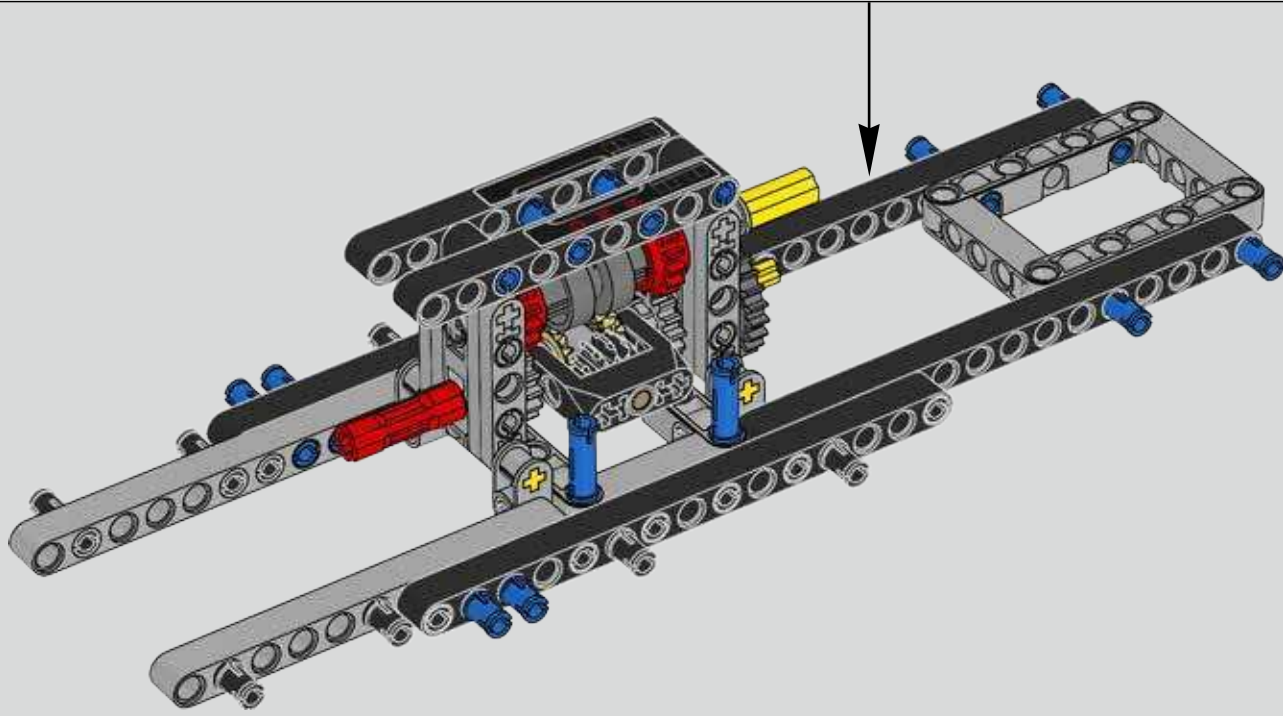

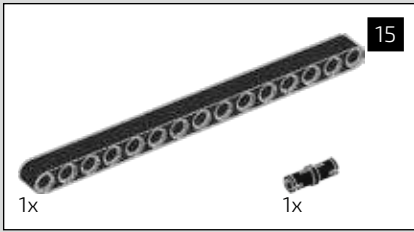

42

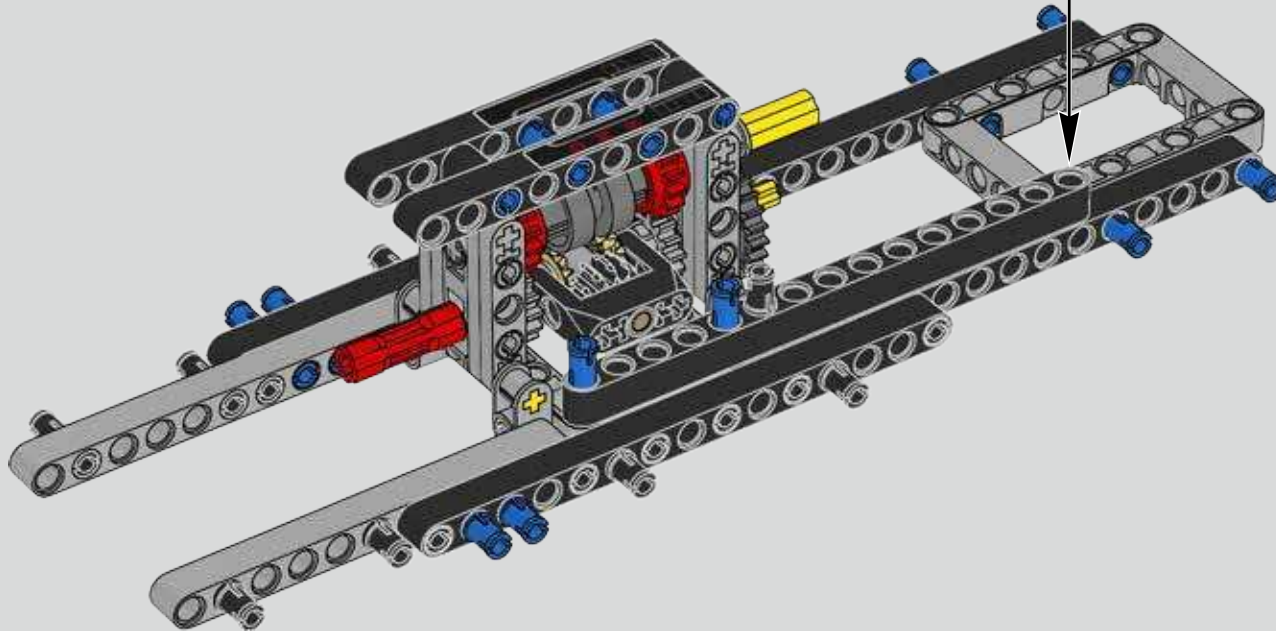
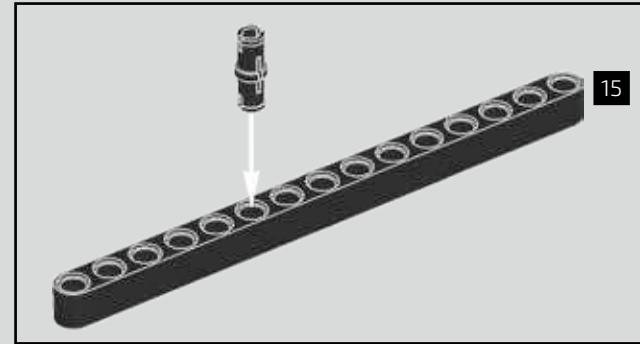

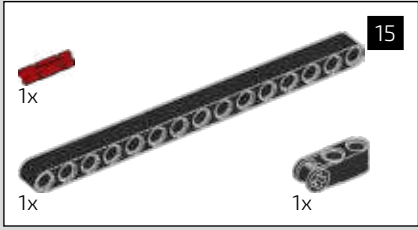

43

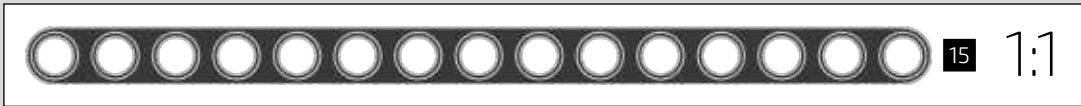
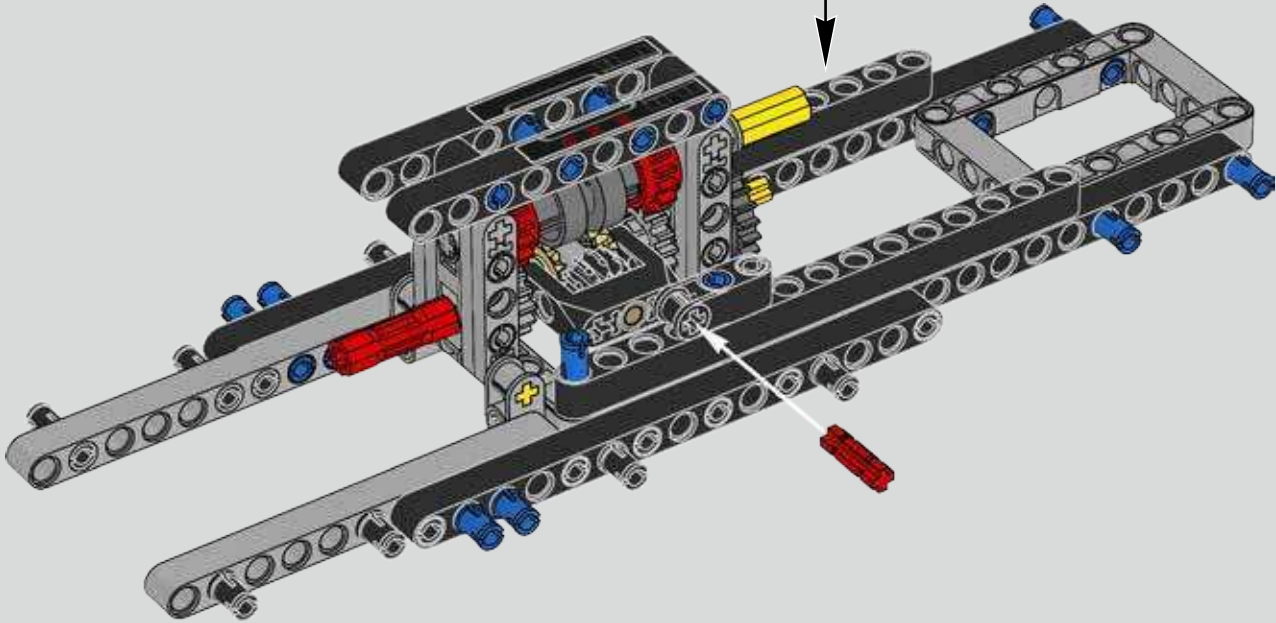
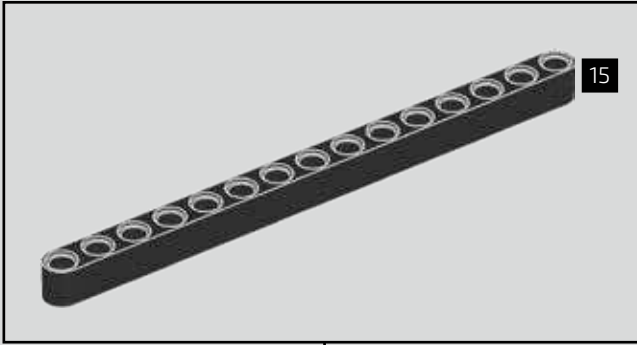



44

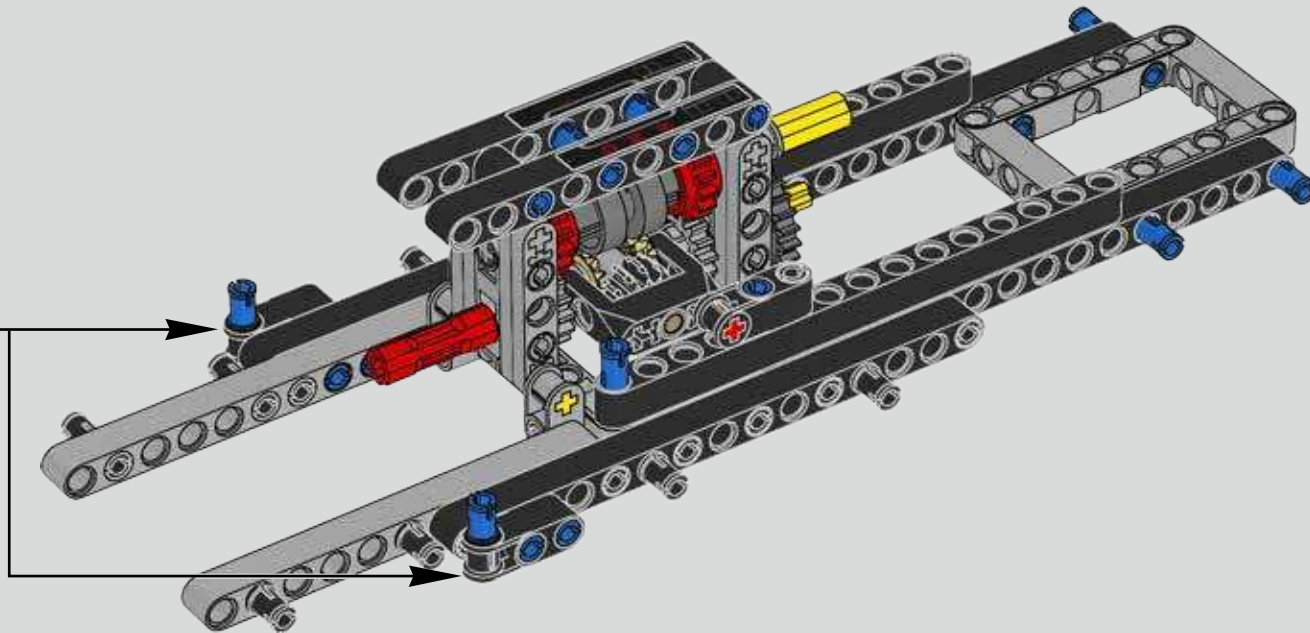
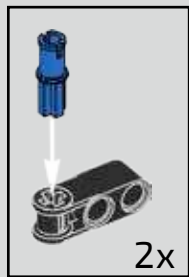

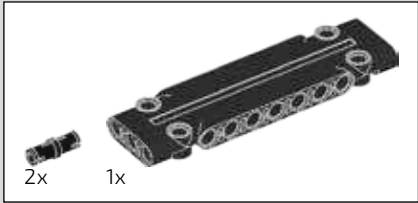
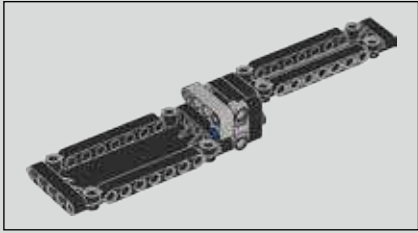

45

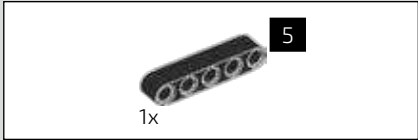
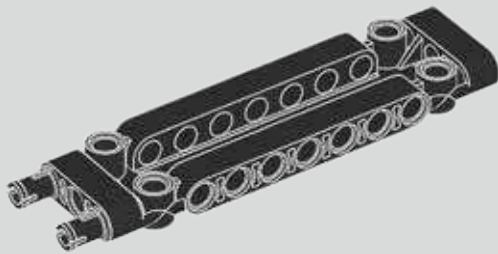

46

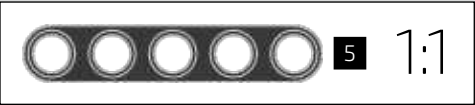
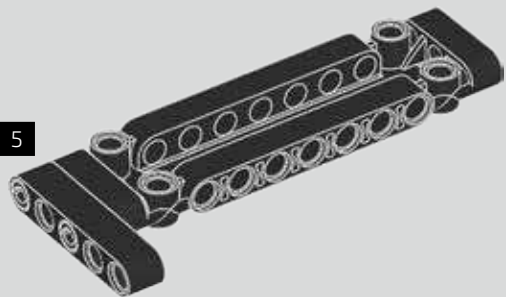

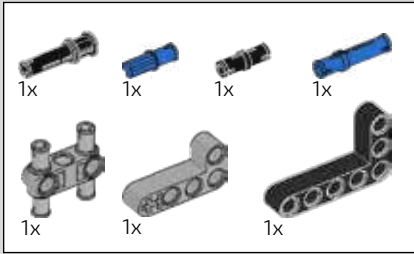

47

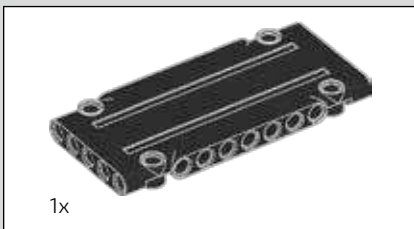
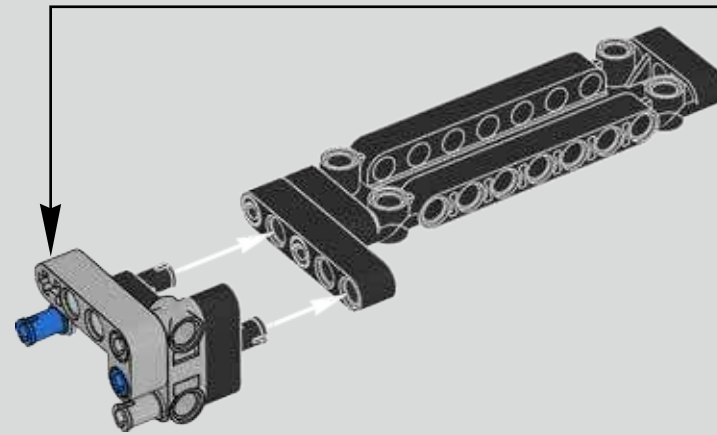
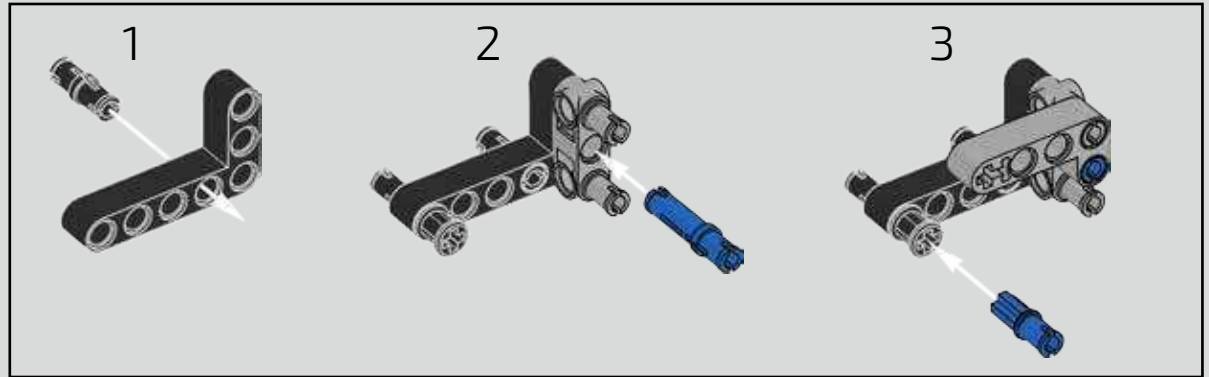

48

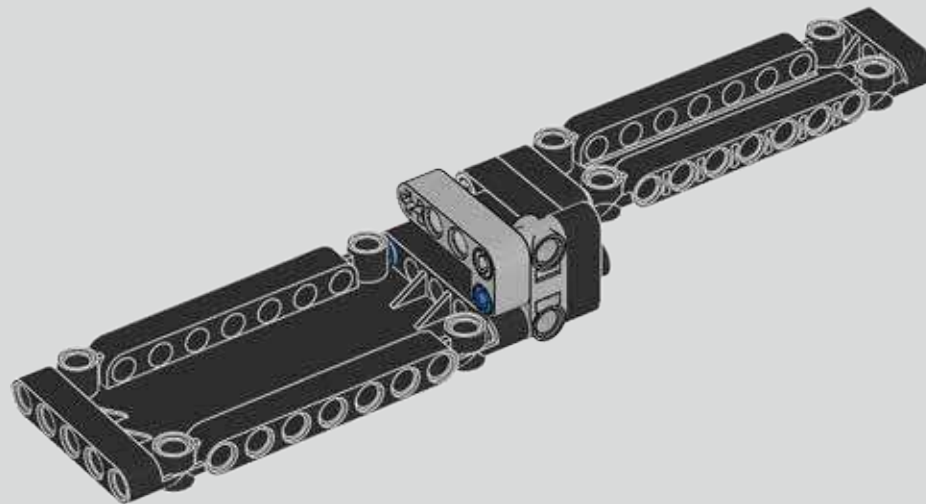

49

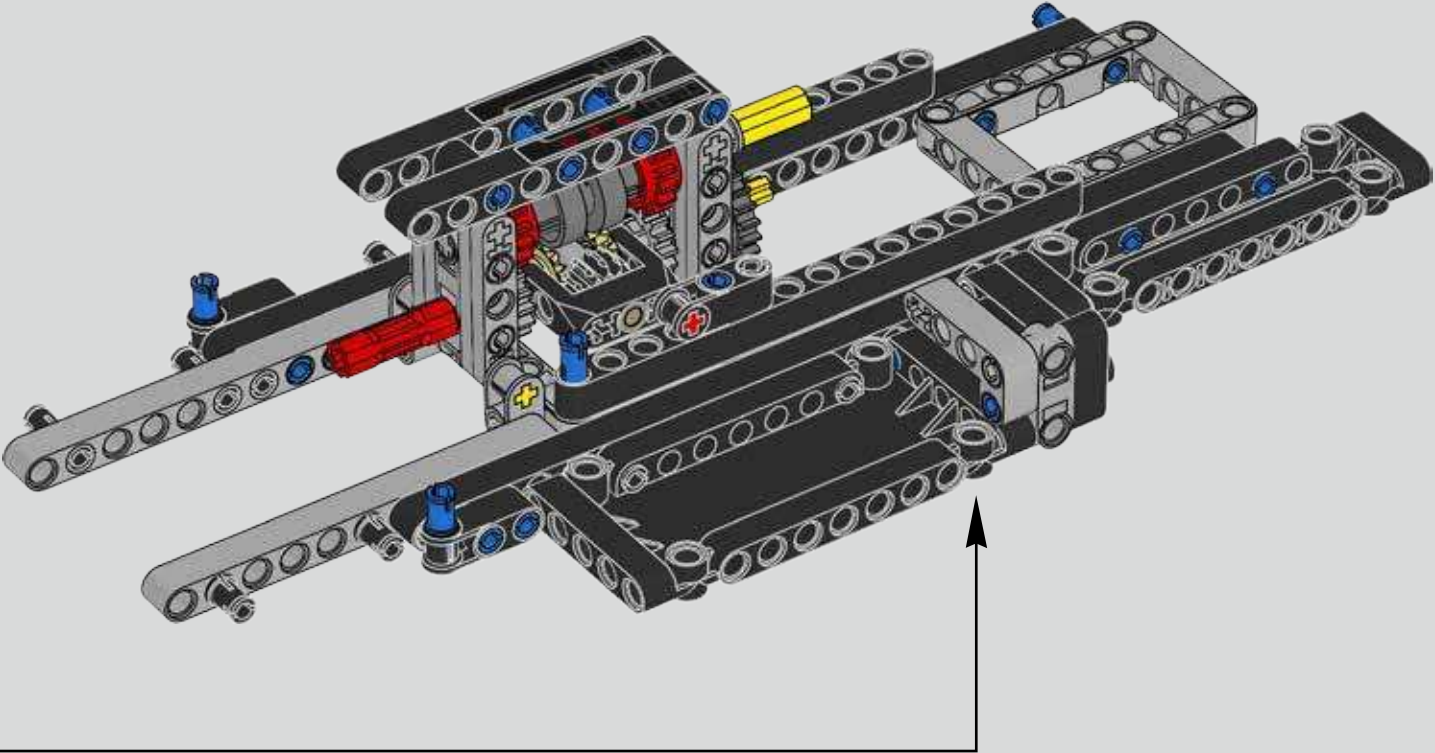

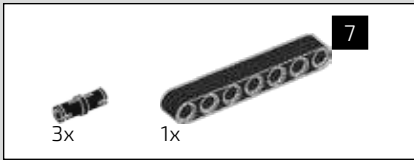

50

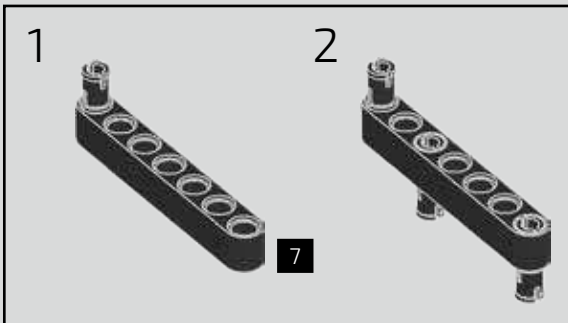
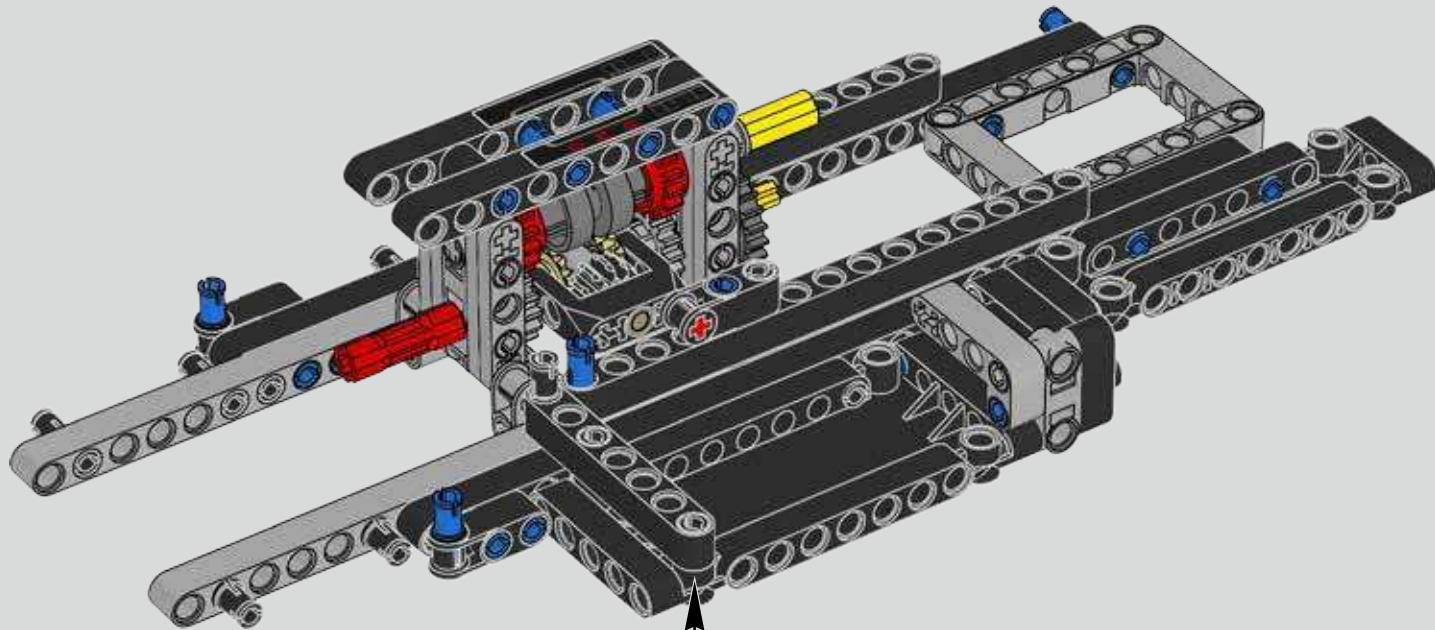

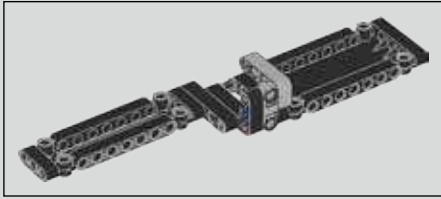

51

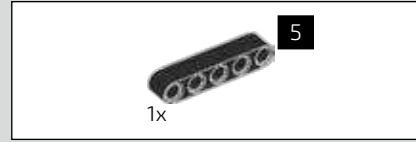
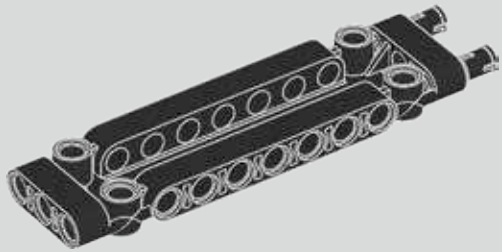

52

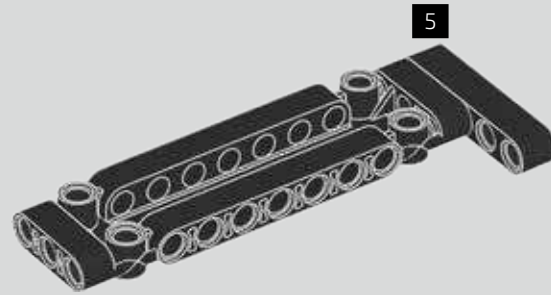

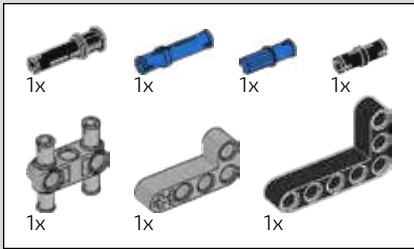

53

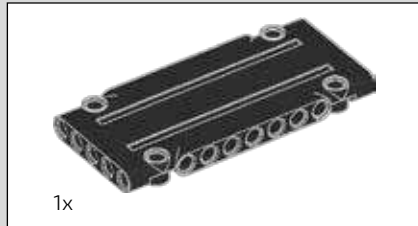
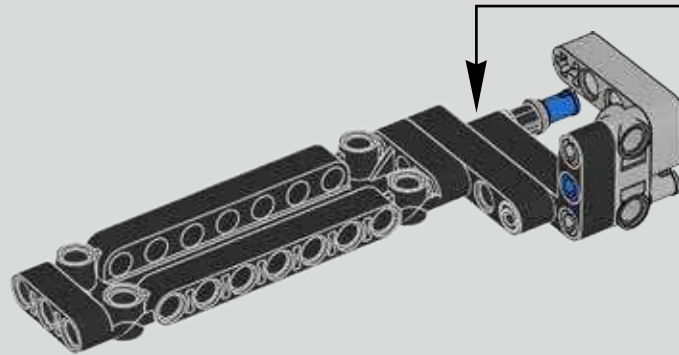
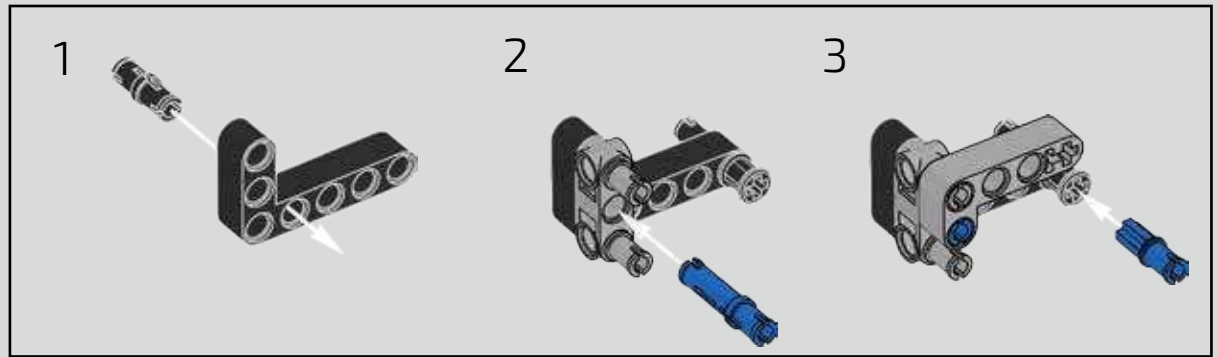

54

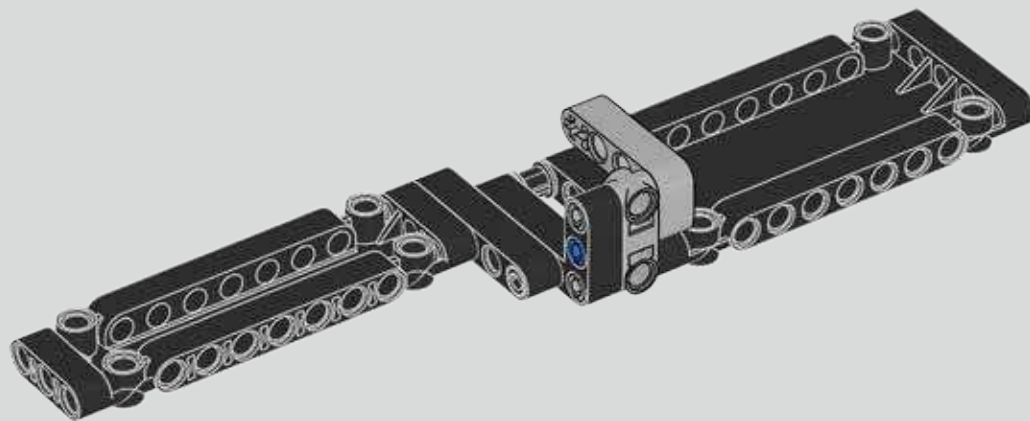

55

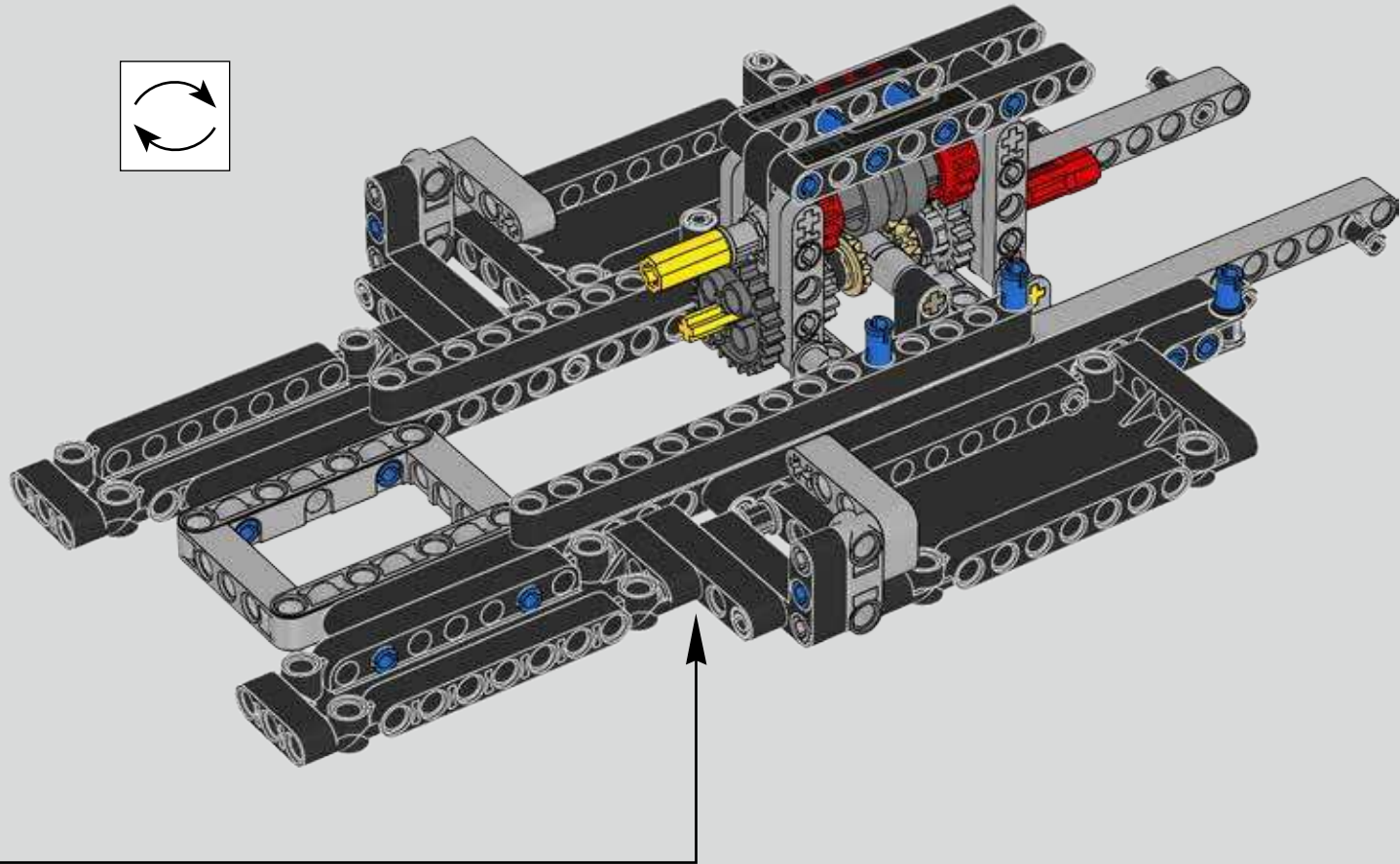
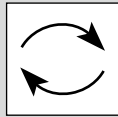

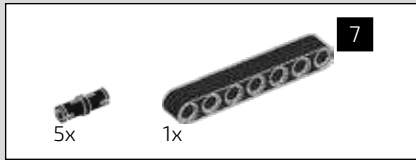

56

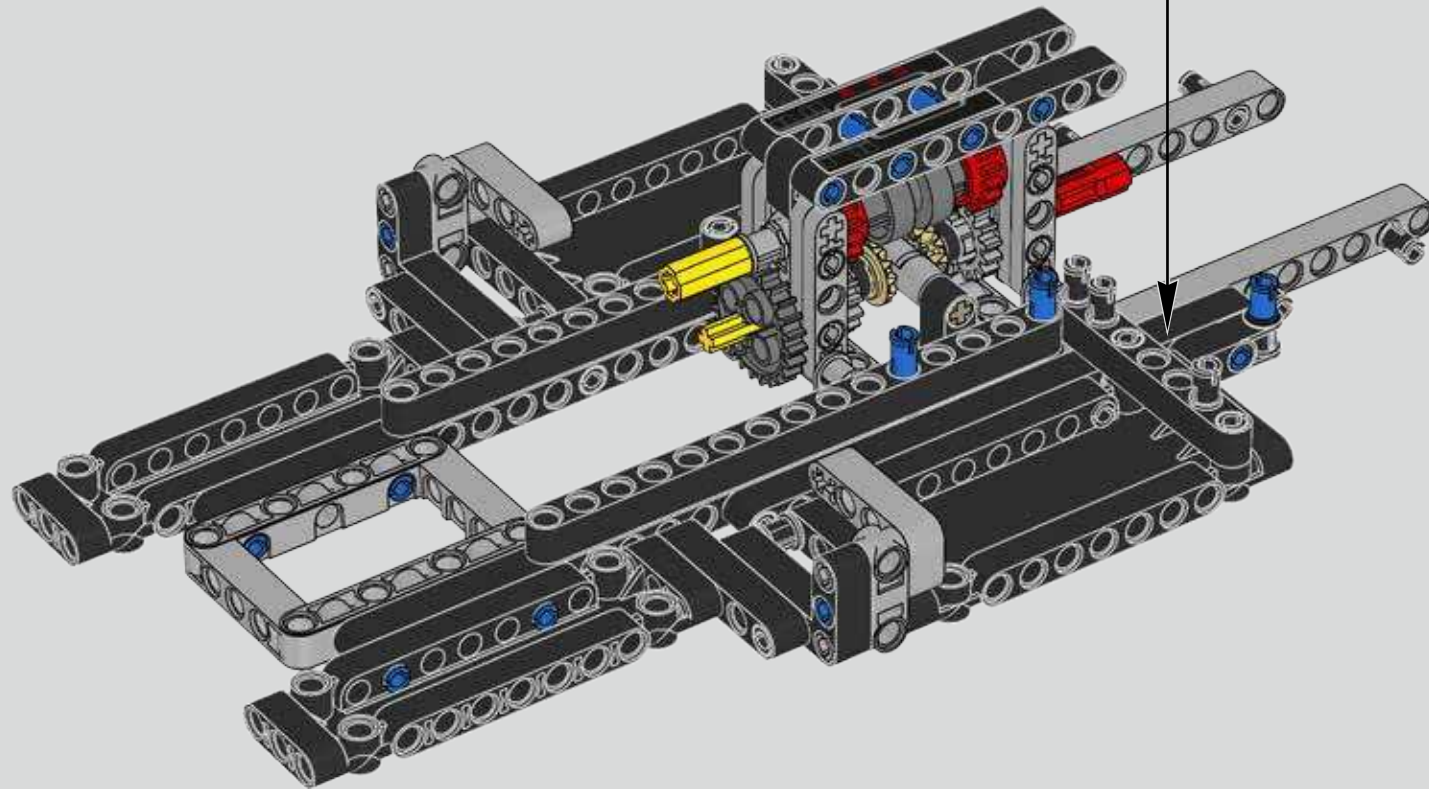
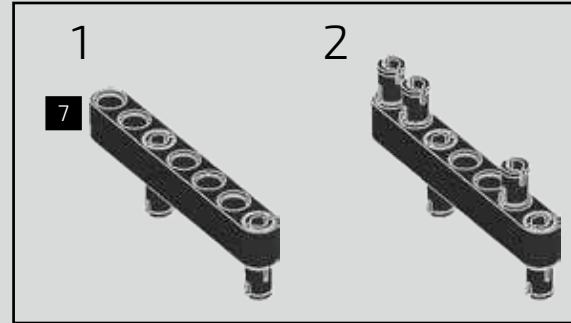

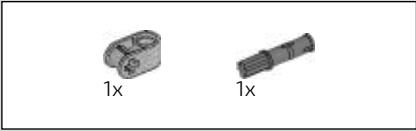

57

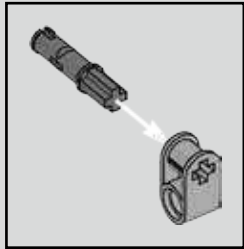
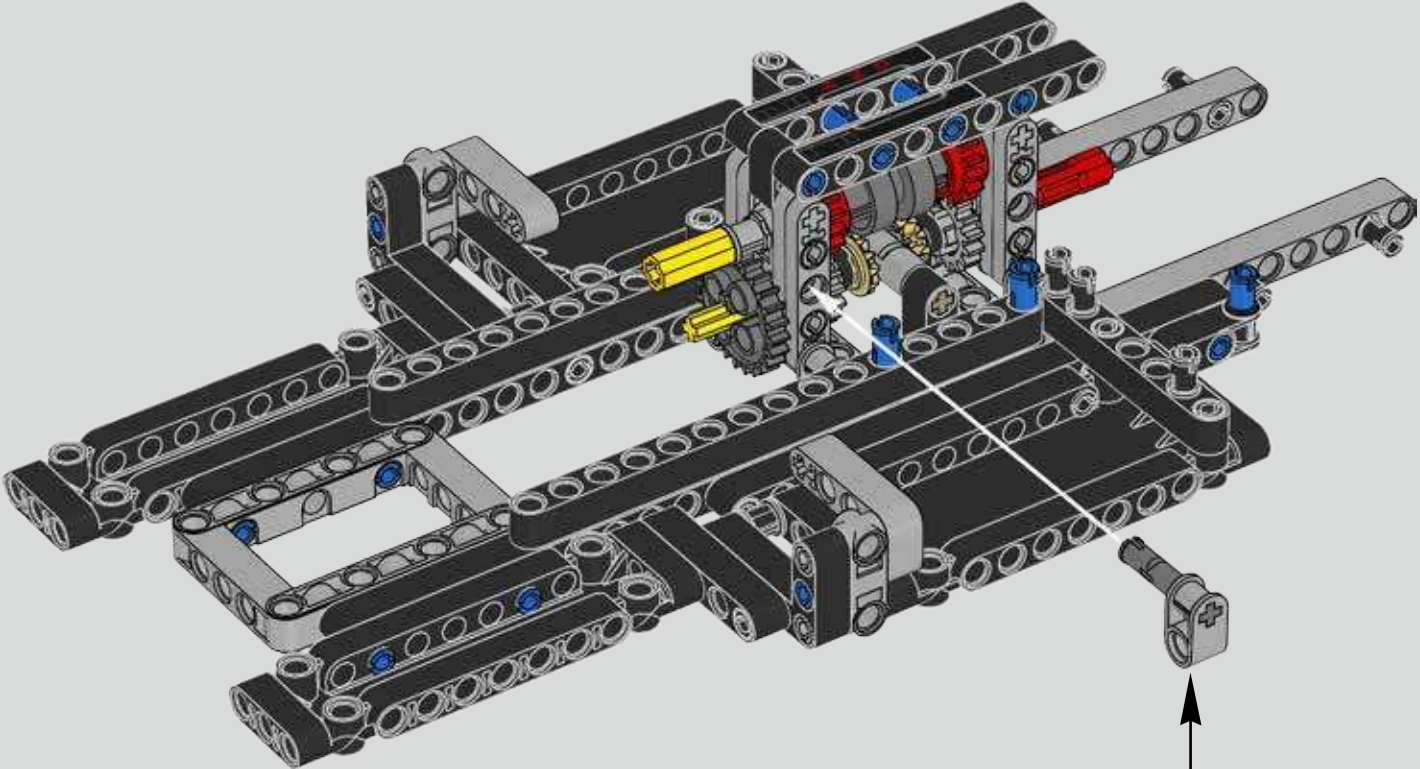

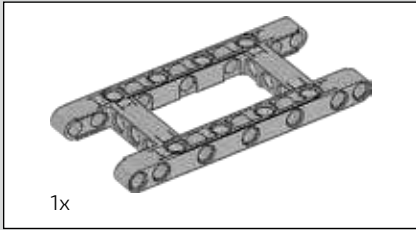
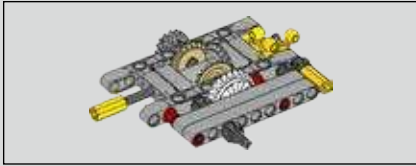

1x

58

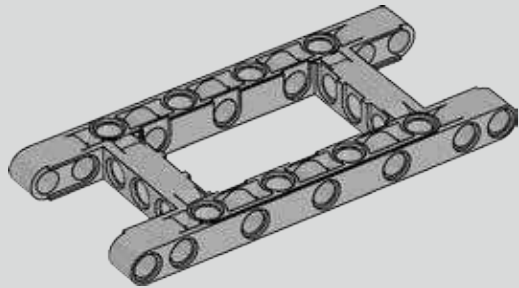

59

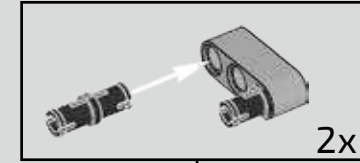

2x

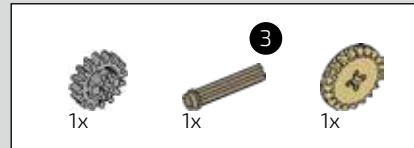
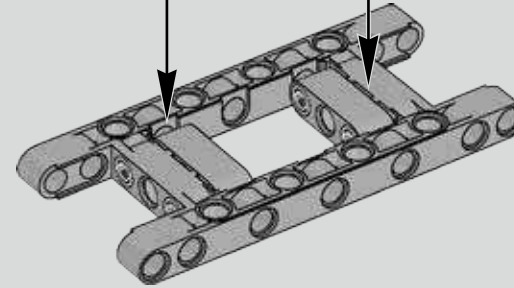

60

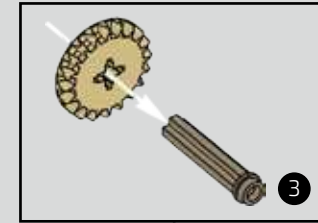

3

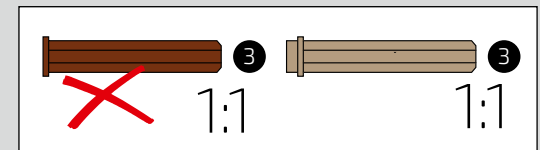
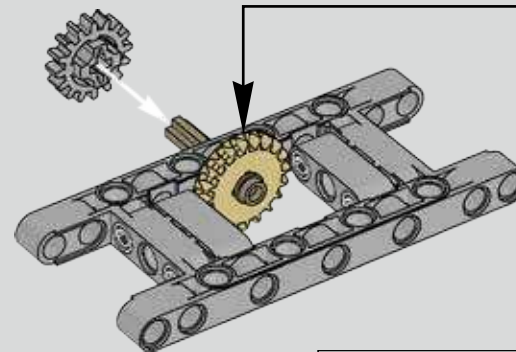

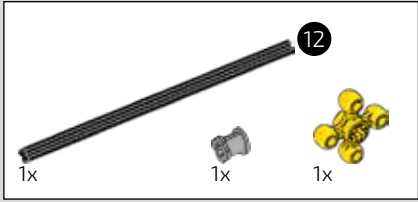

61

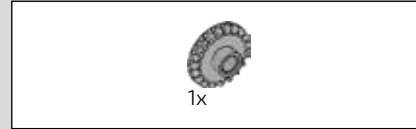
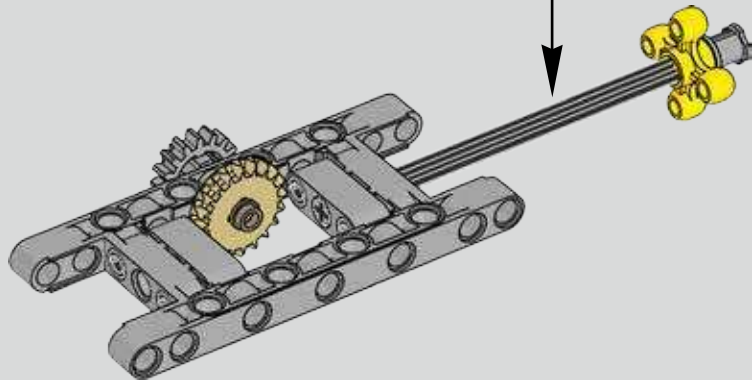
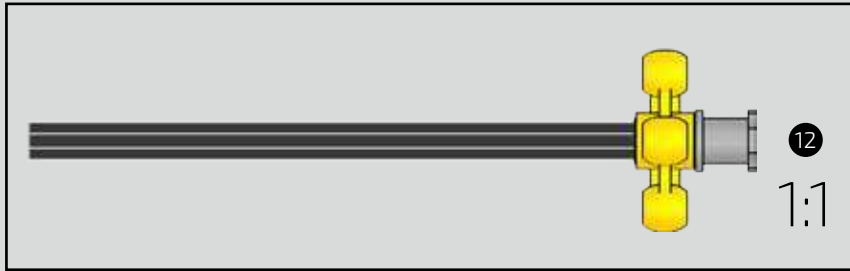

62

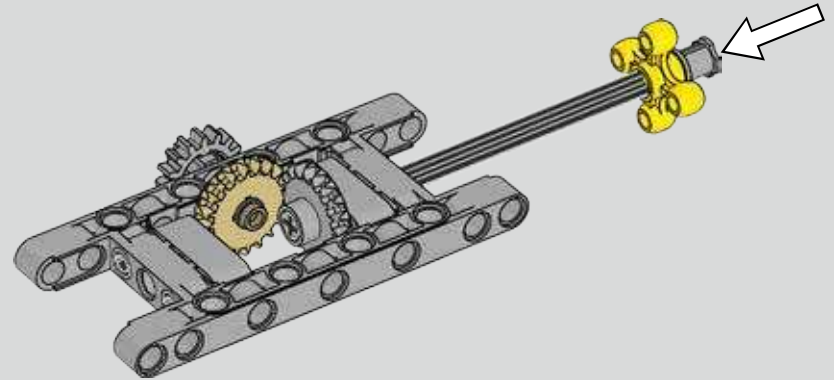

63

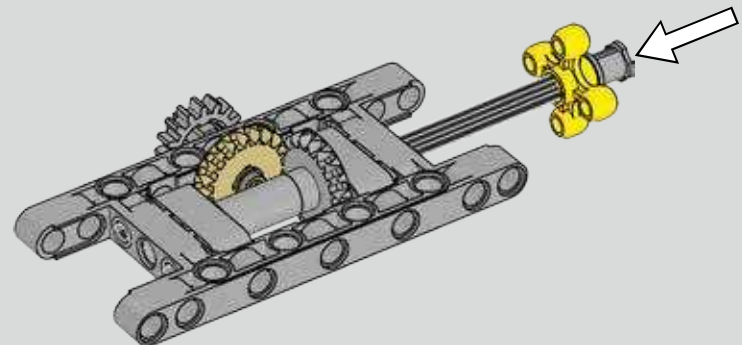

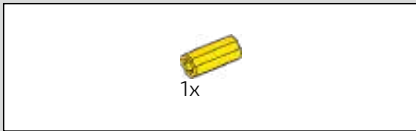

64

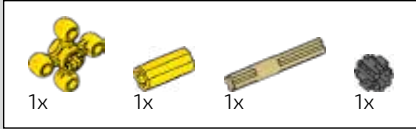
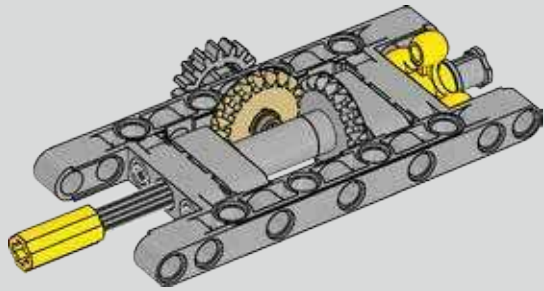

65

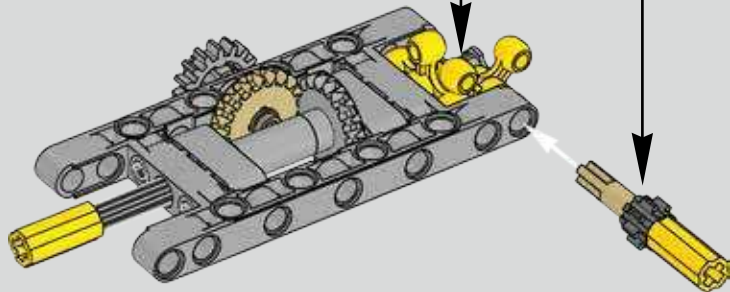
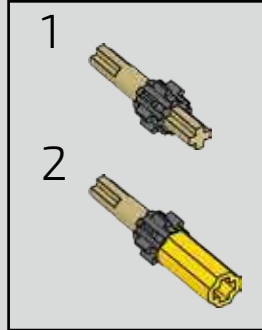
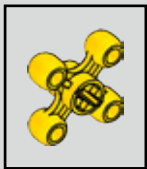

66

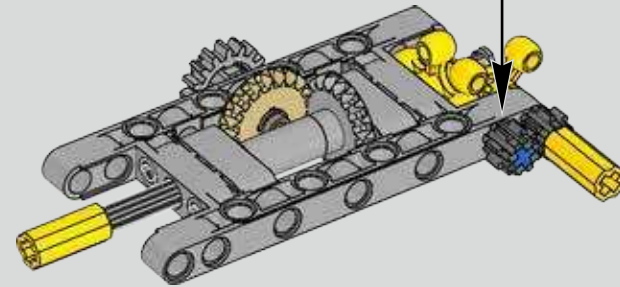
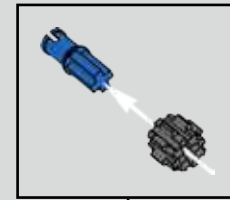
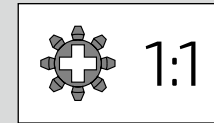



67

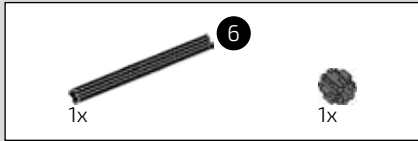
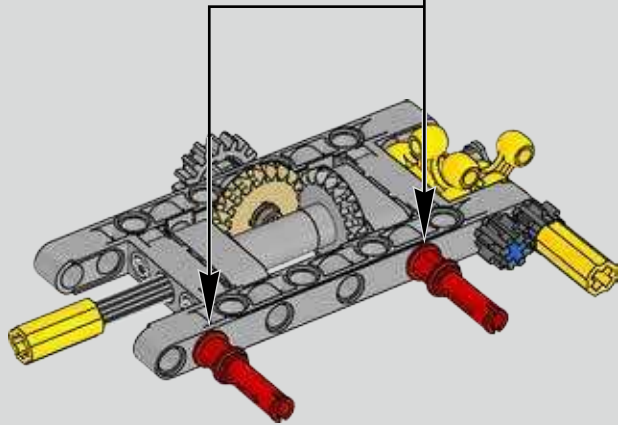
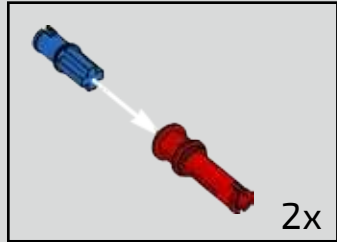

68

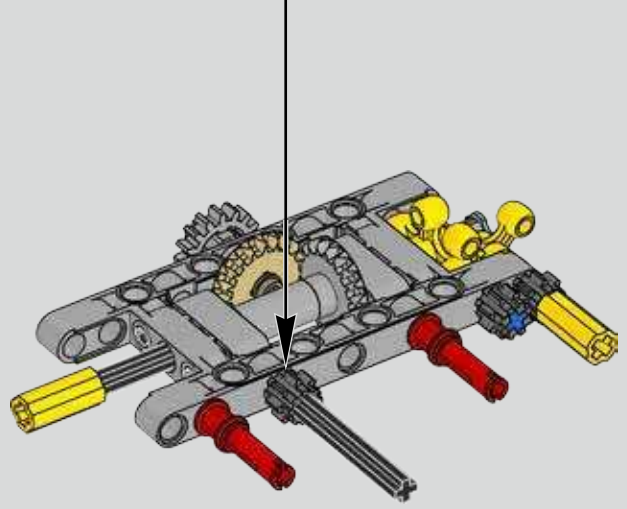

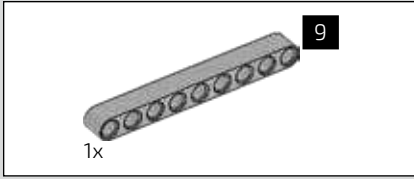

69

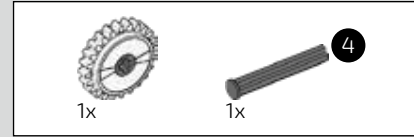
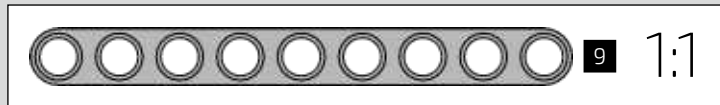
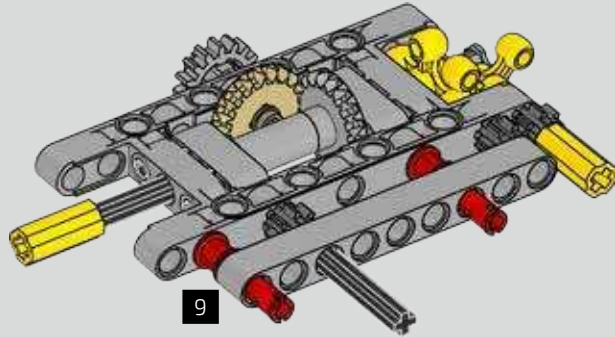

70

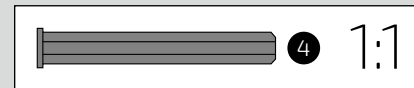
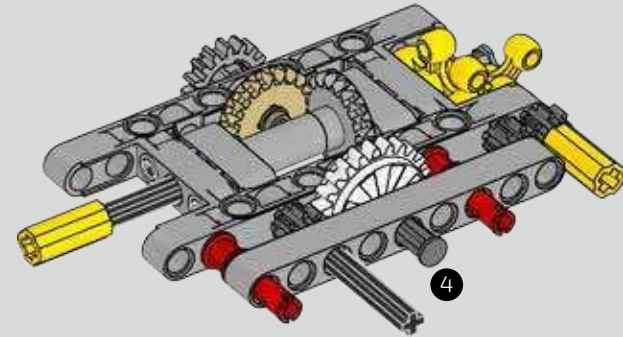

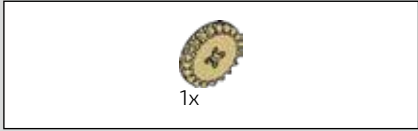

71

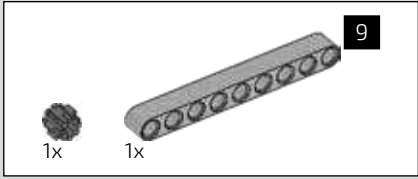
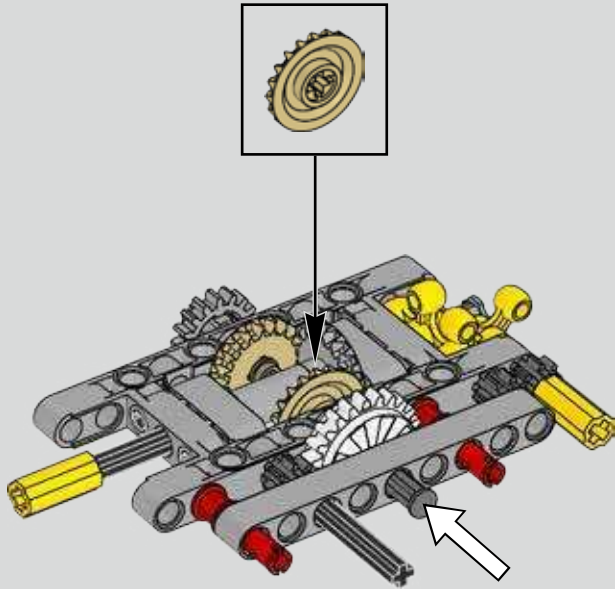

72

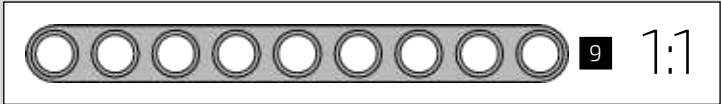
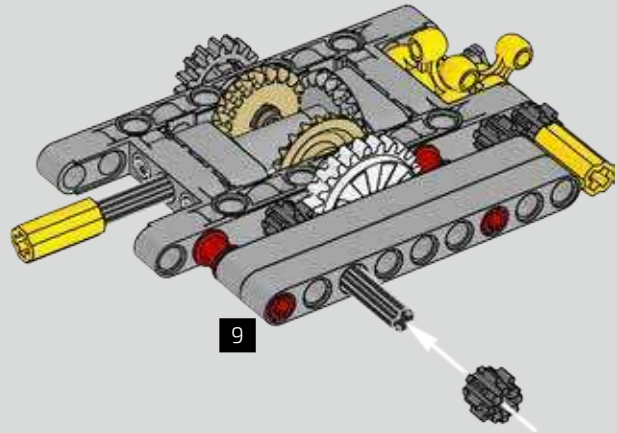

73

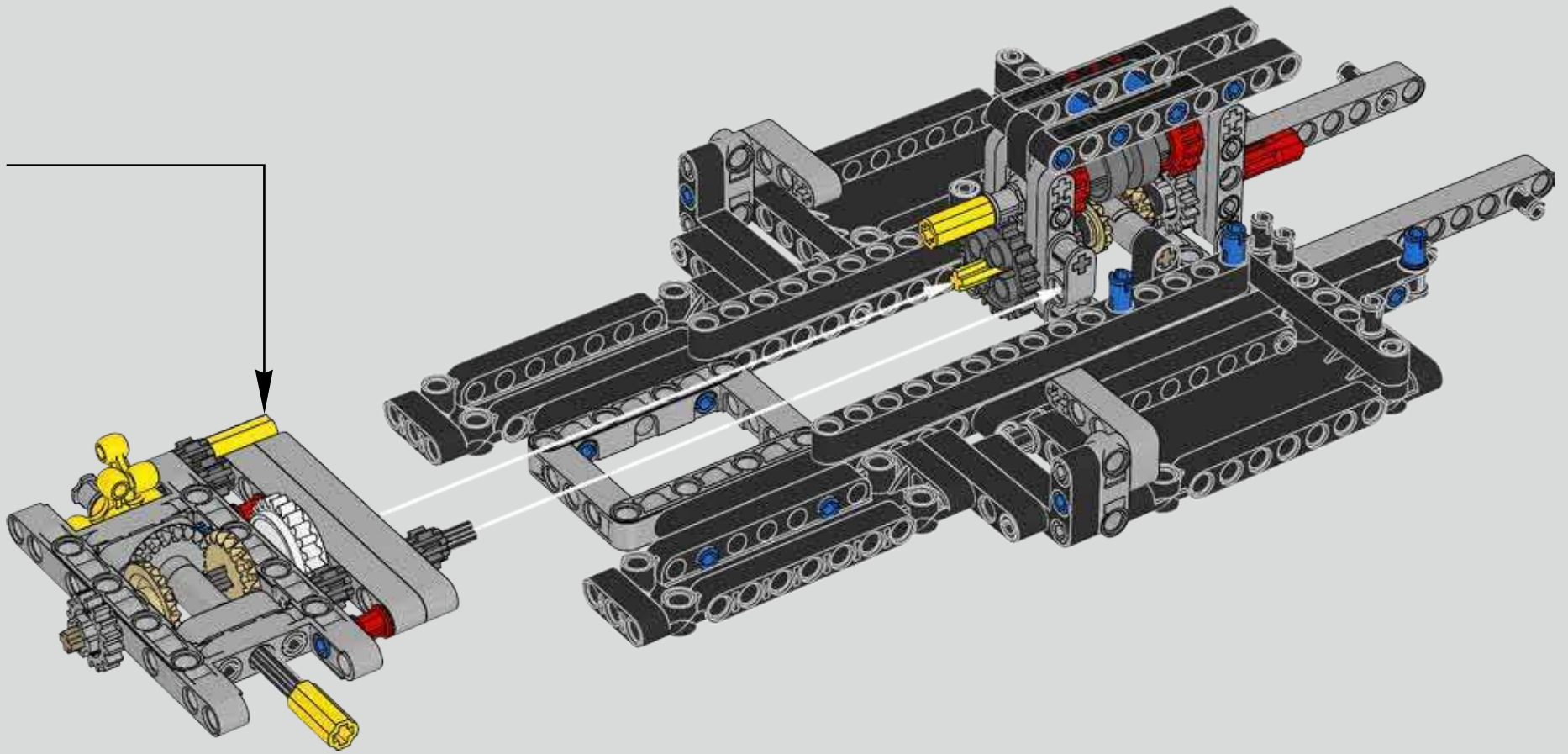



74

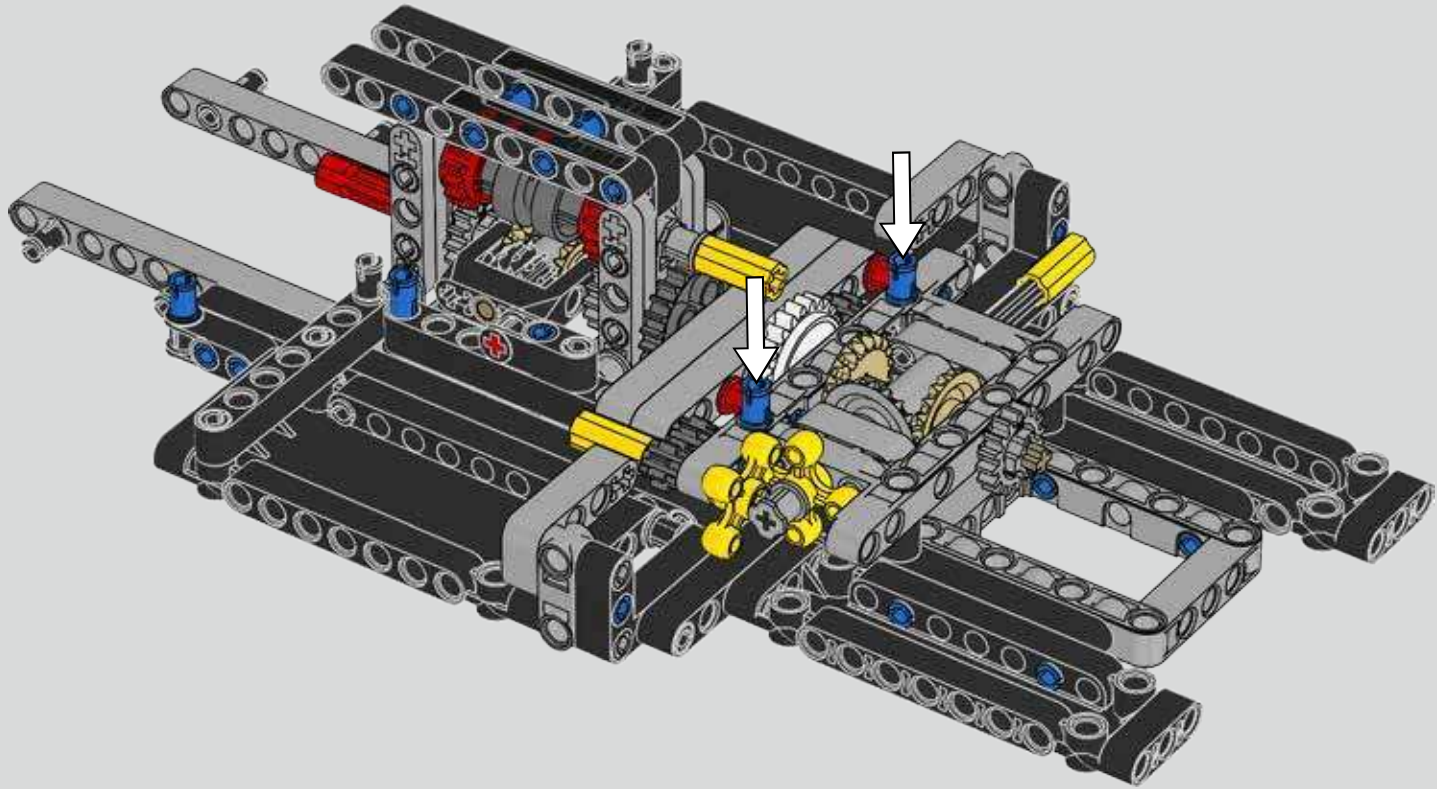
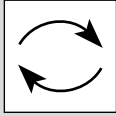

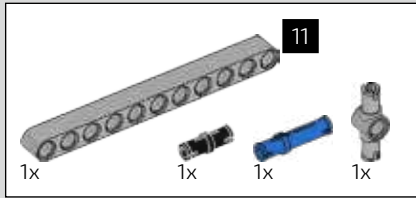

75

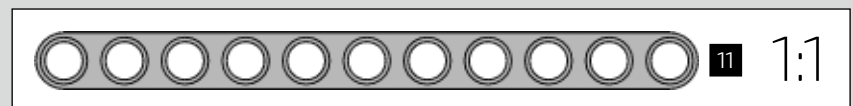
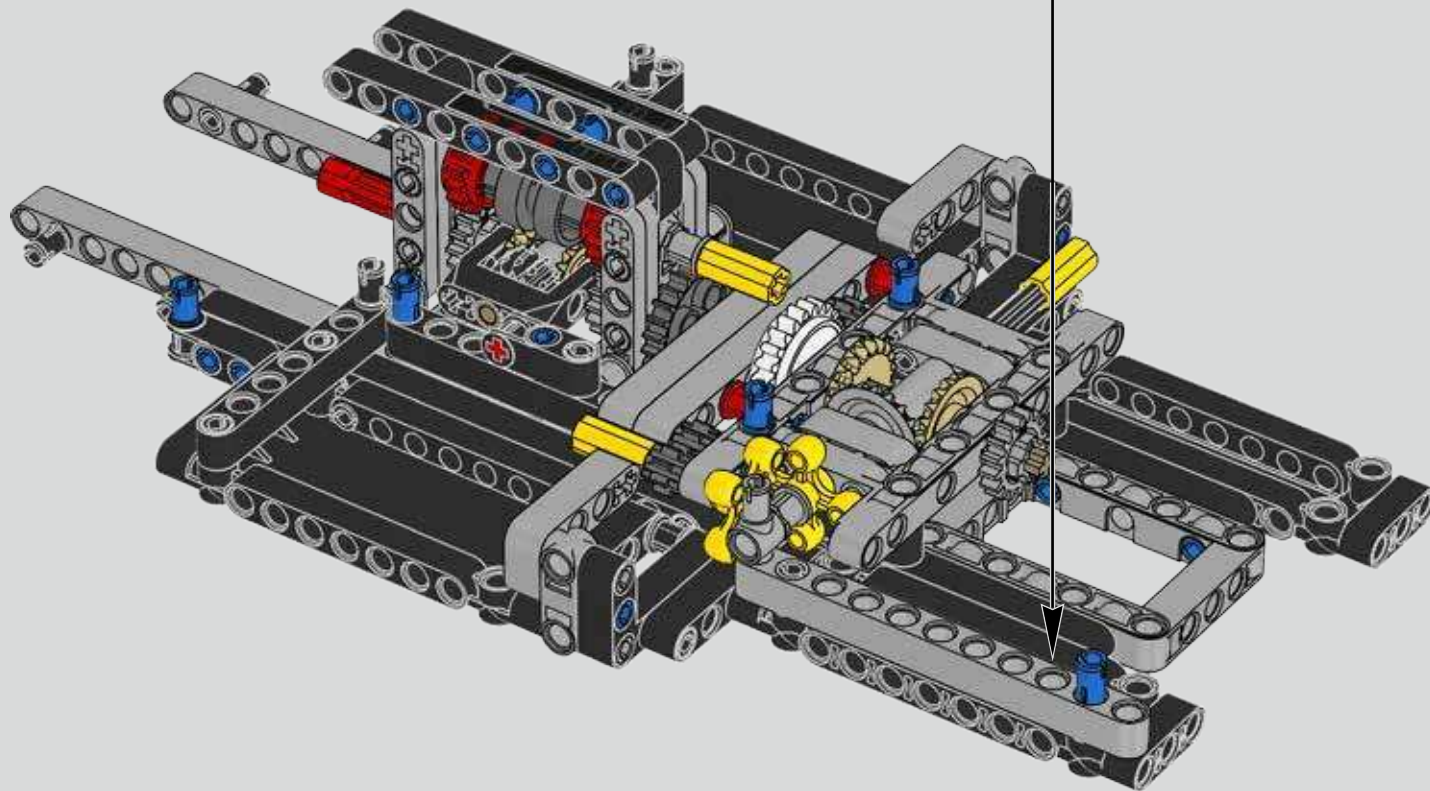
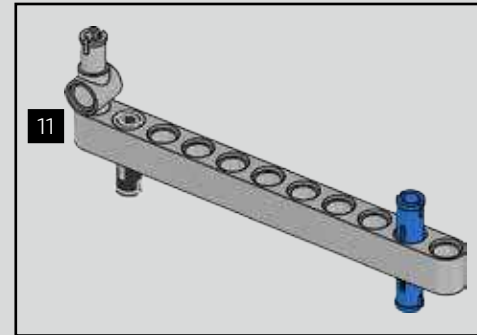

76

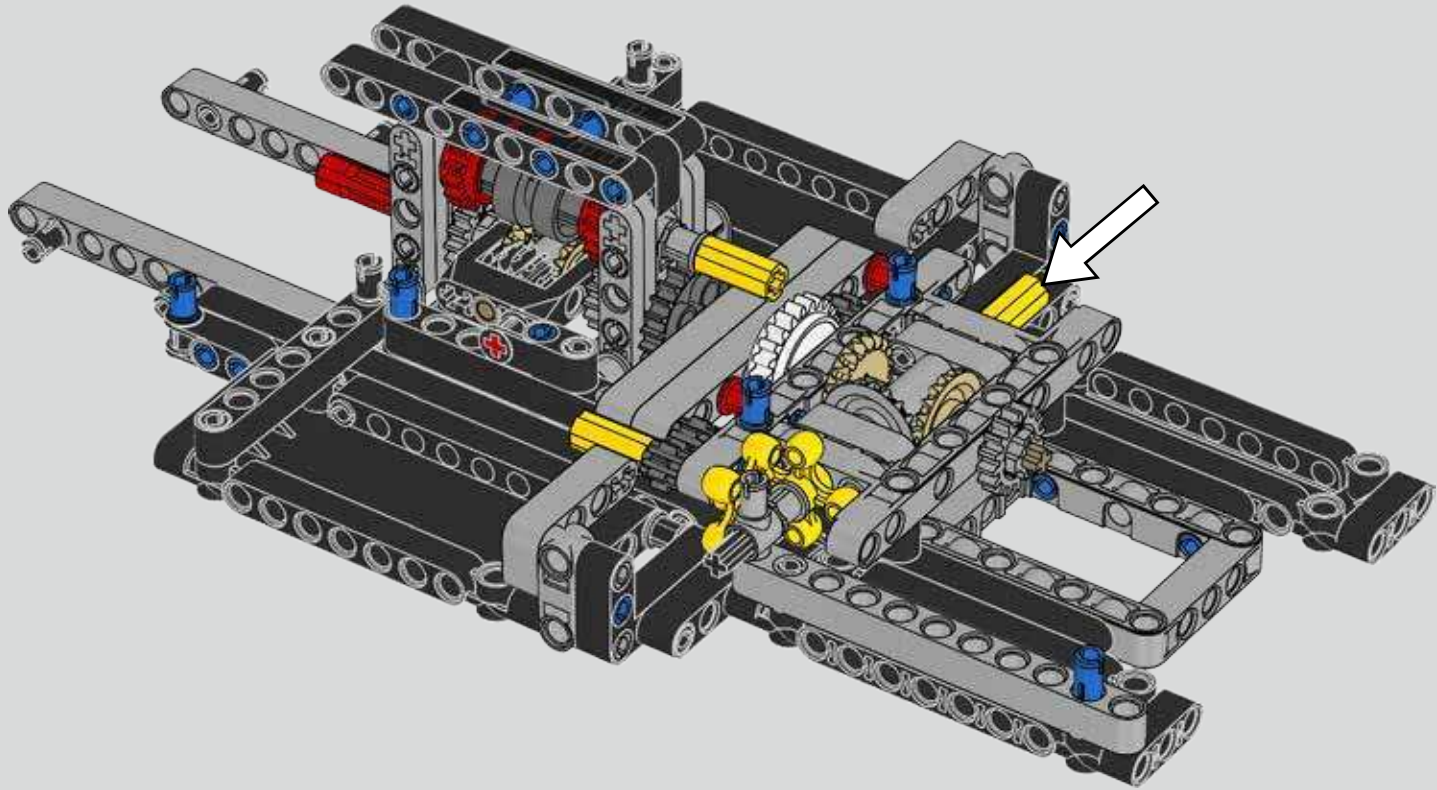

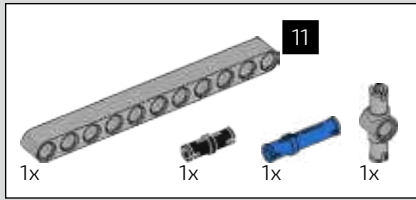

77

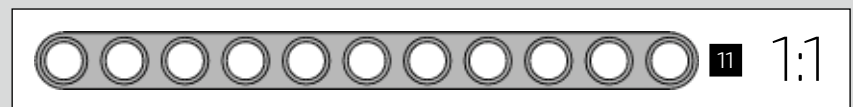
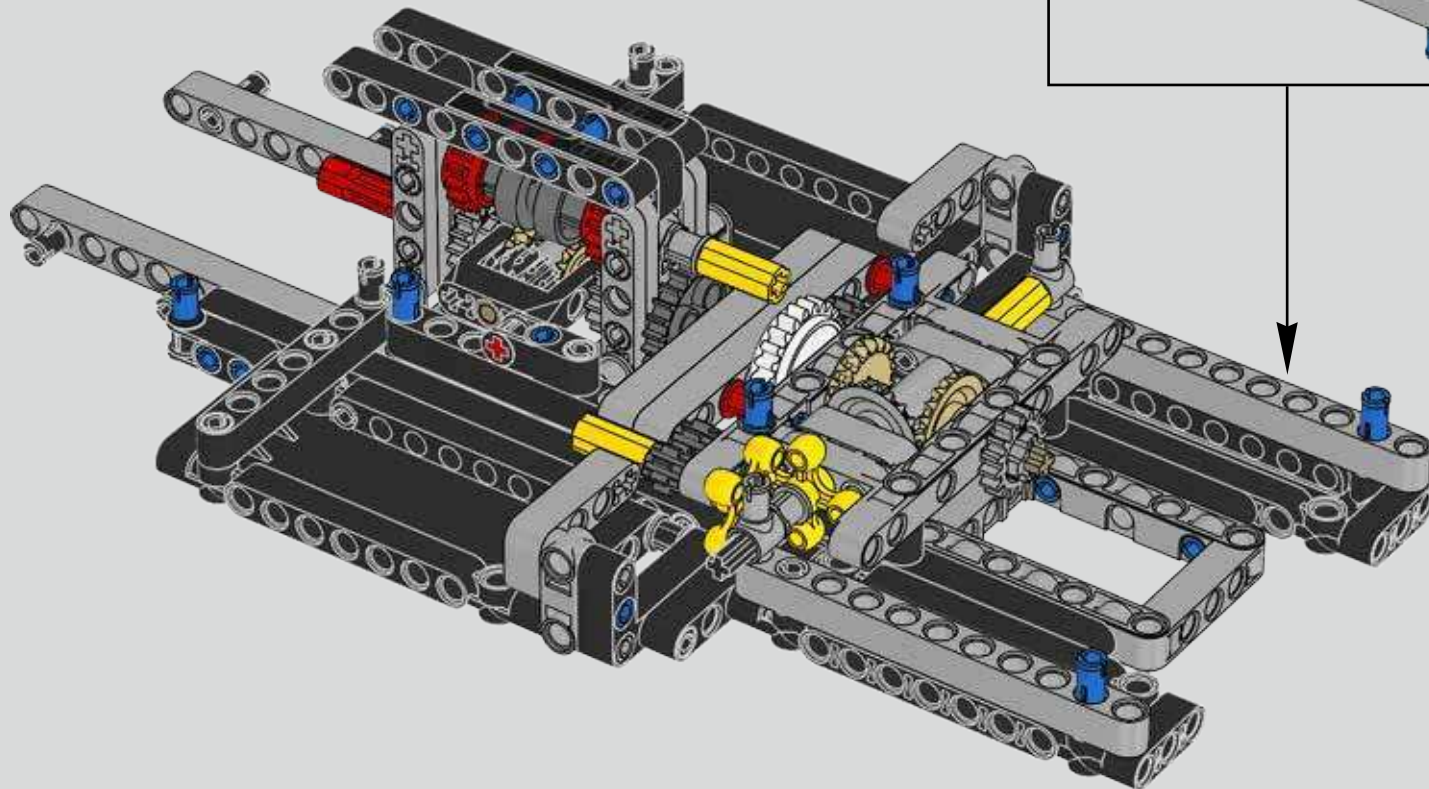
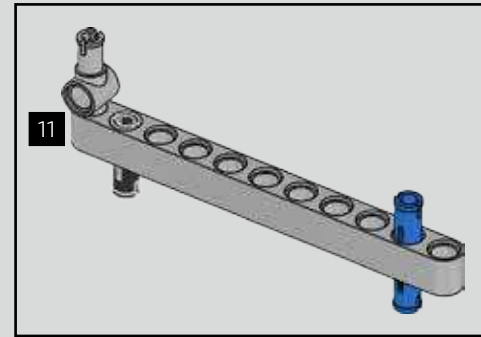



78

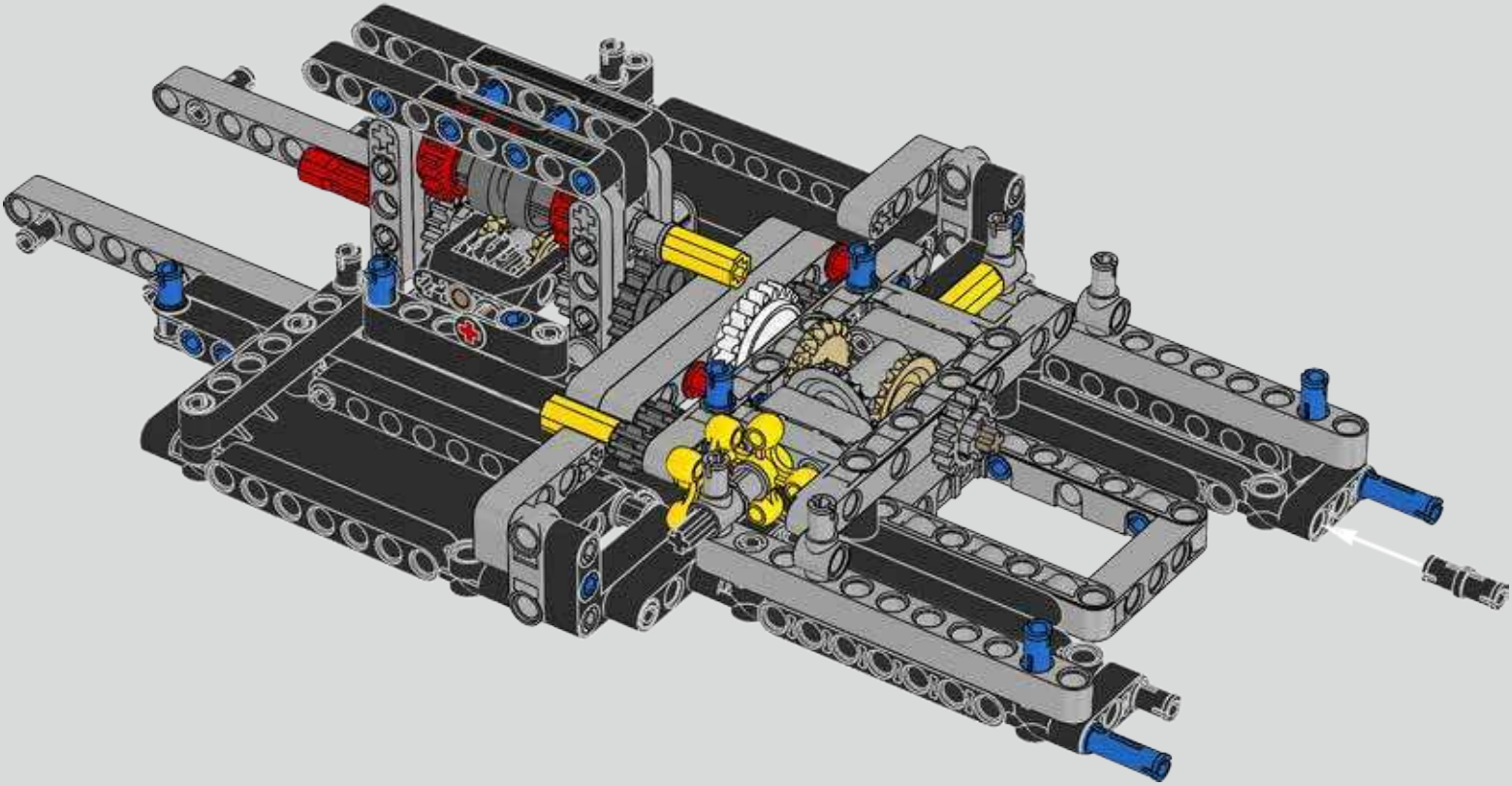

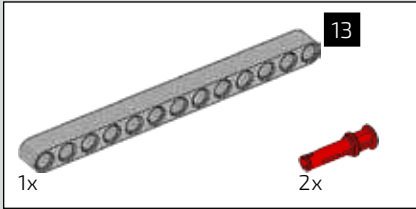
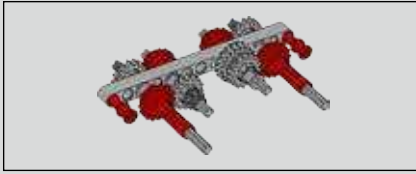

79

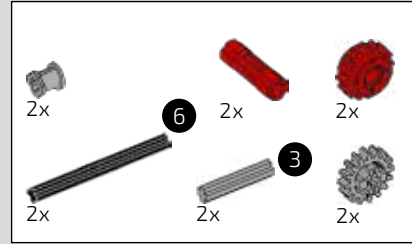
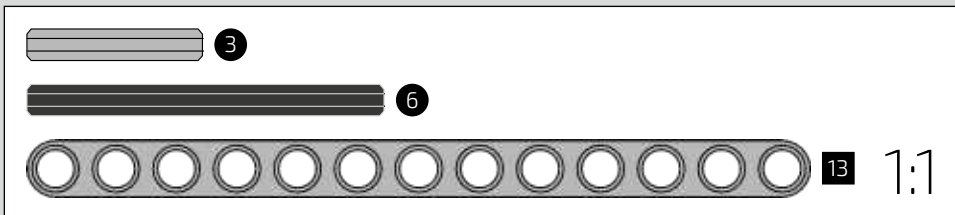
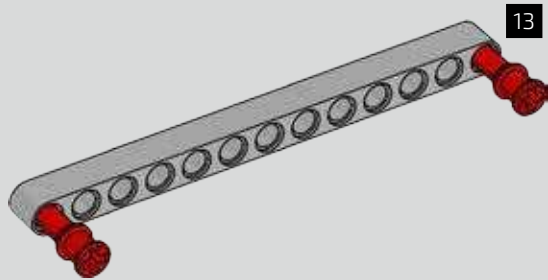

80

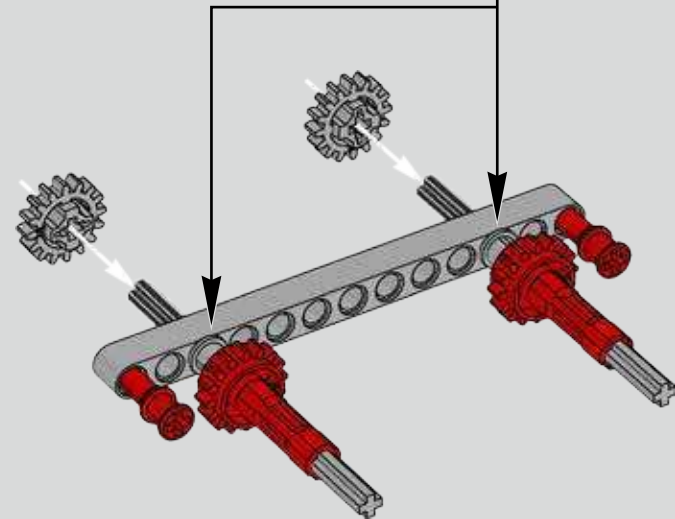
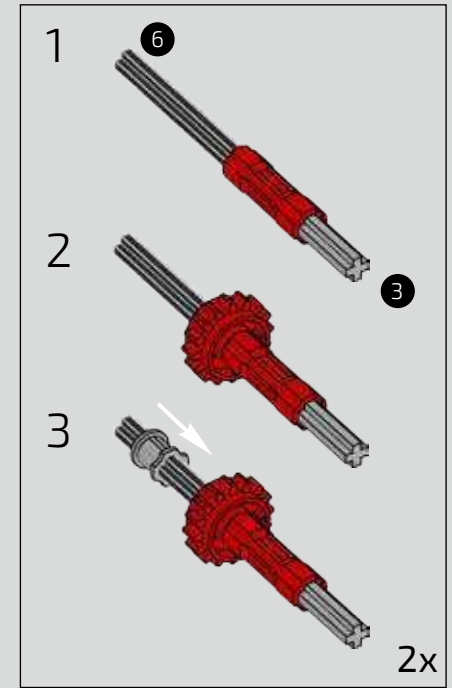

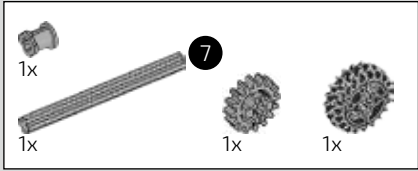

81

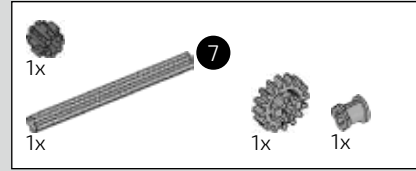
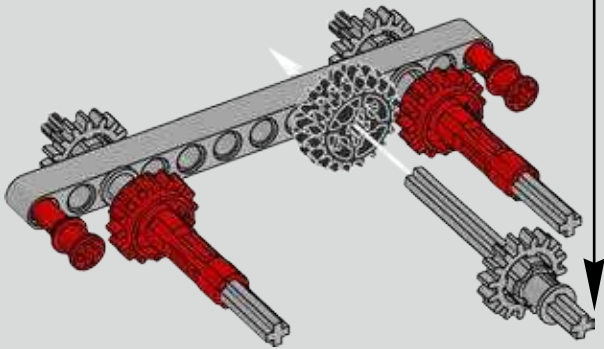
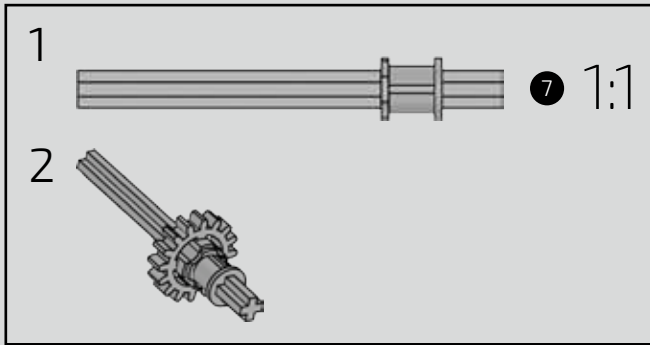

82

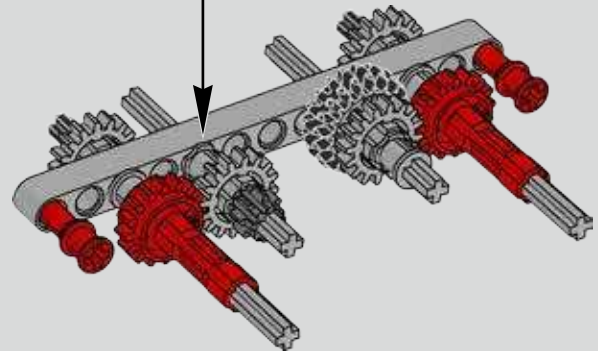
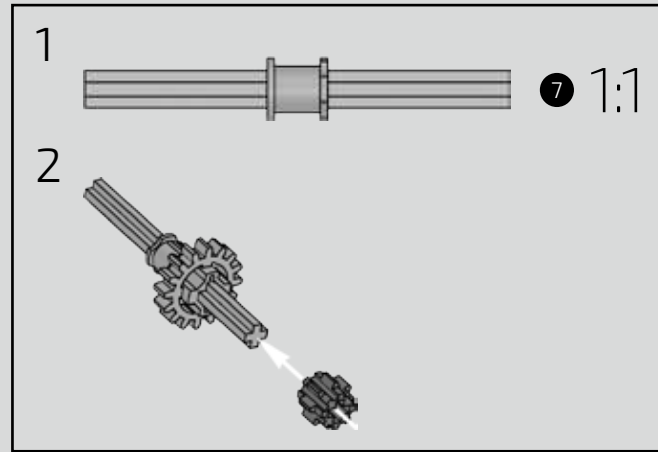
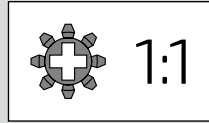



83

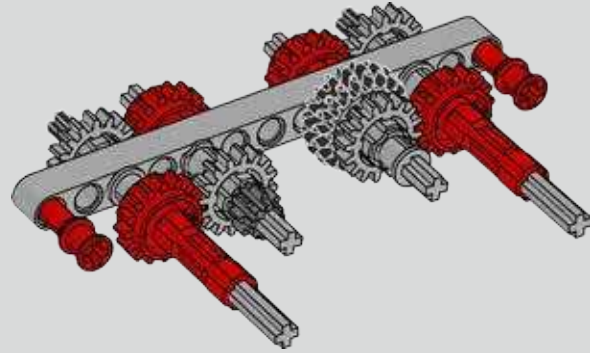

84

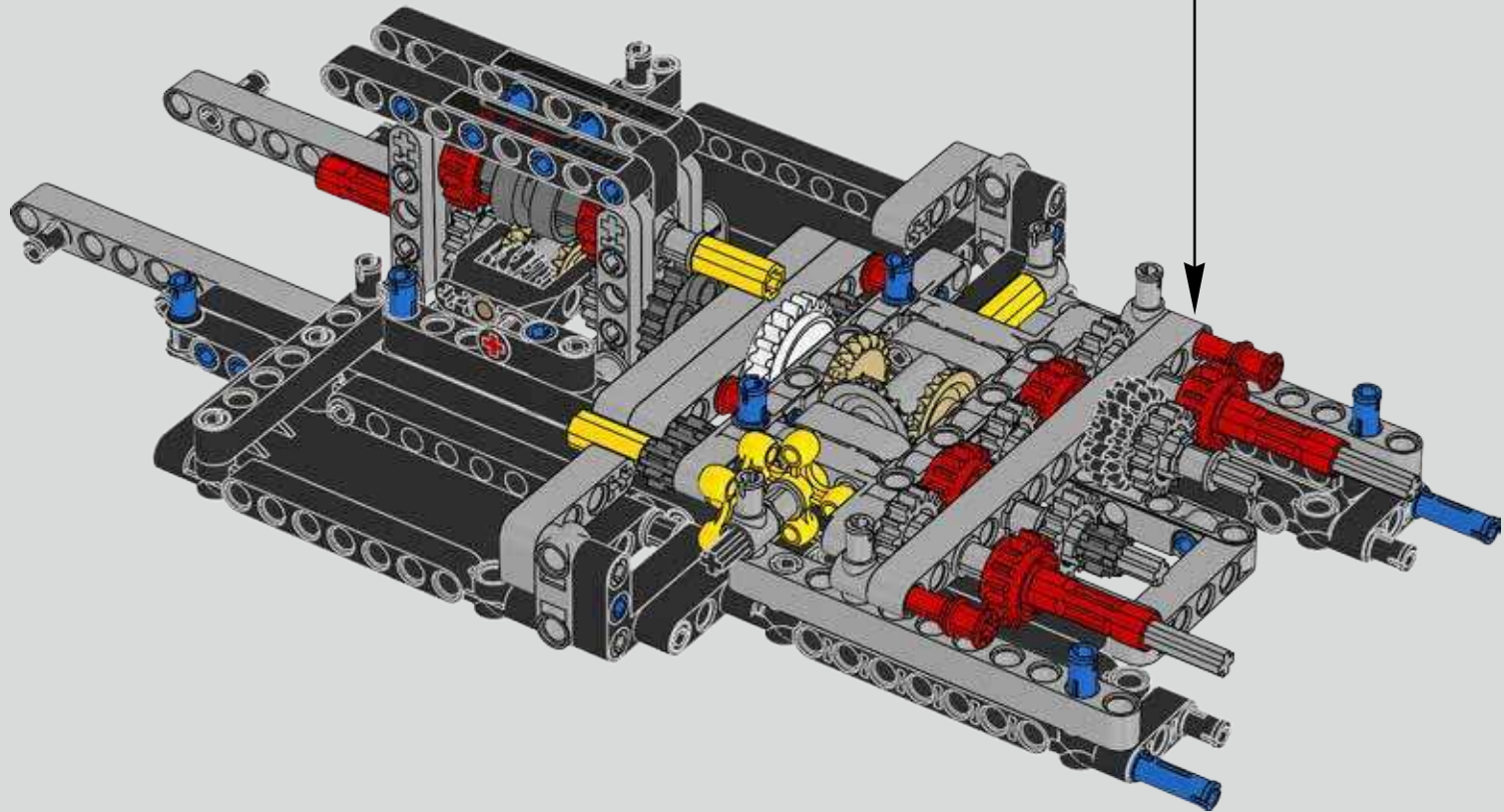

85

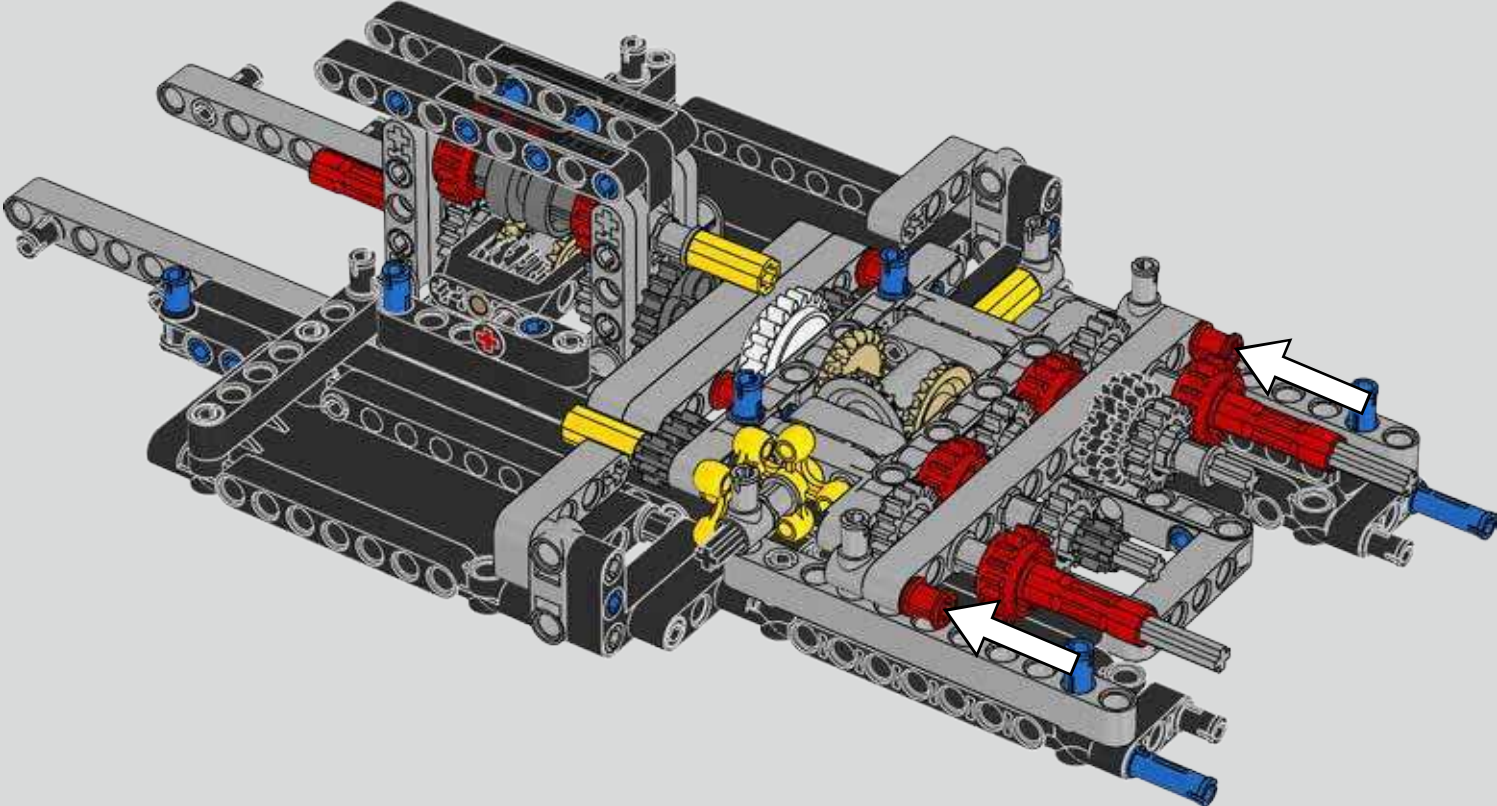

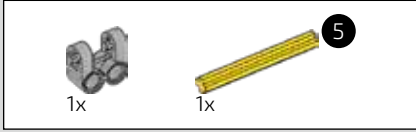
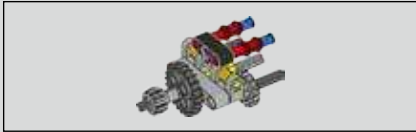

86

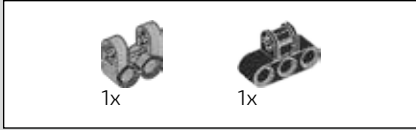
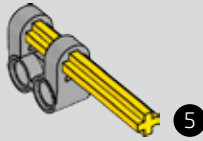

87

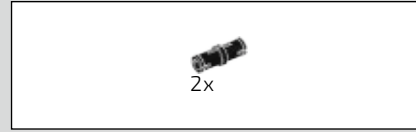
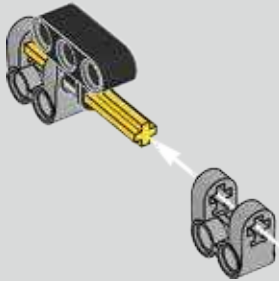

88

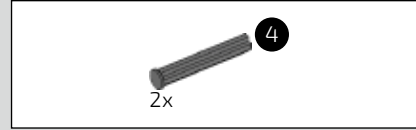
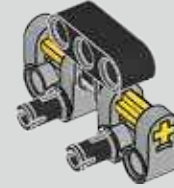

89

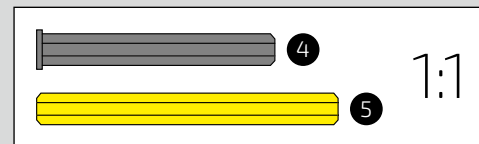
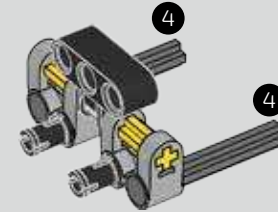

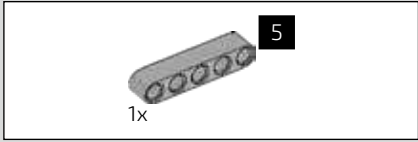

90

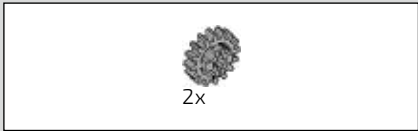
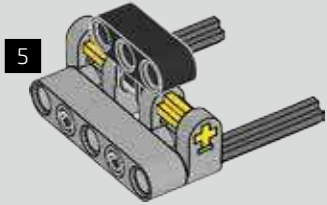

91

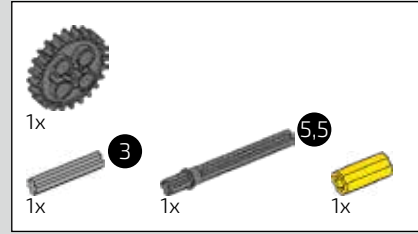
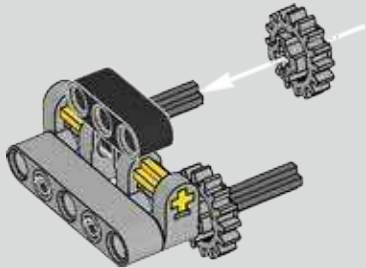

92

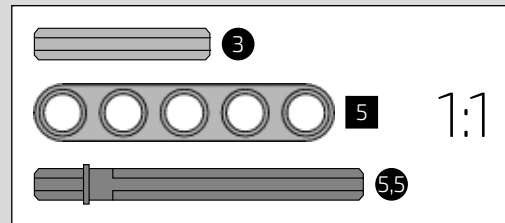
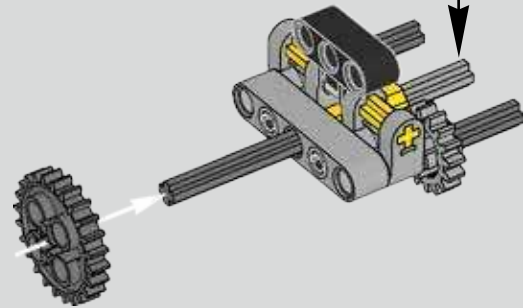
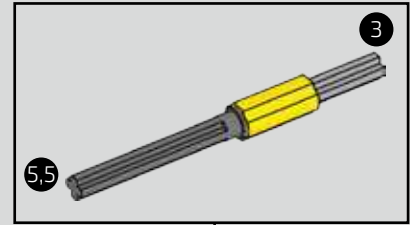

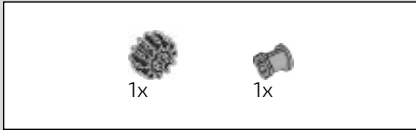

93

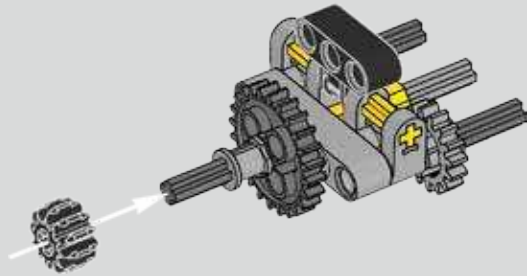

94

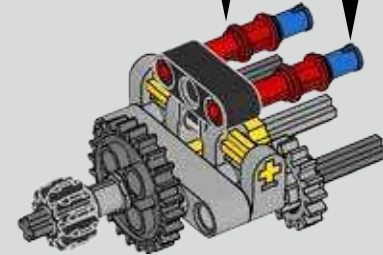
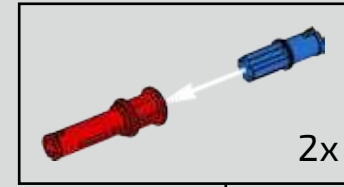

95

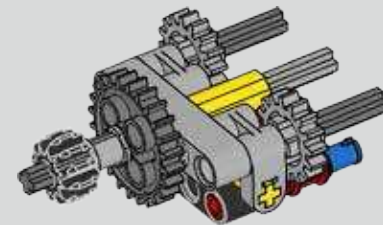
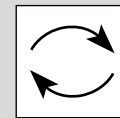

96

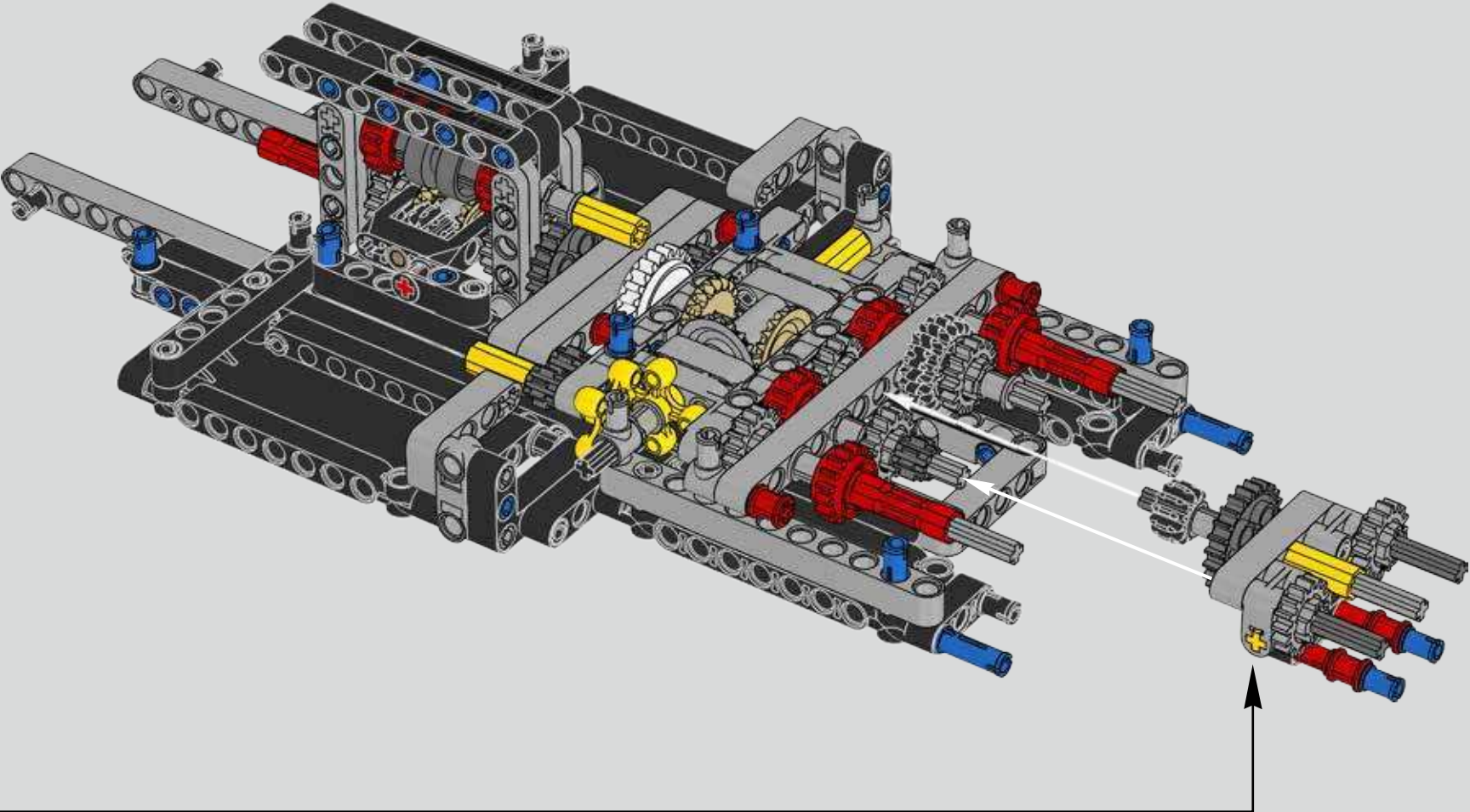

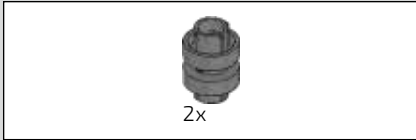

97

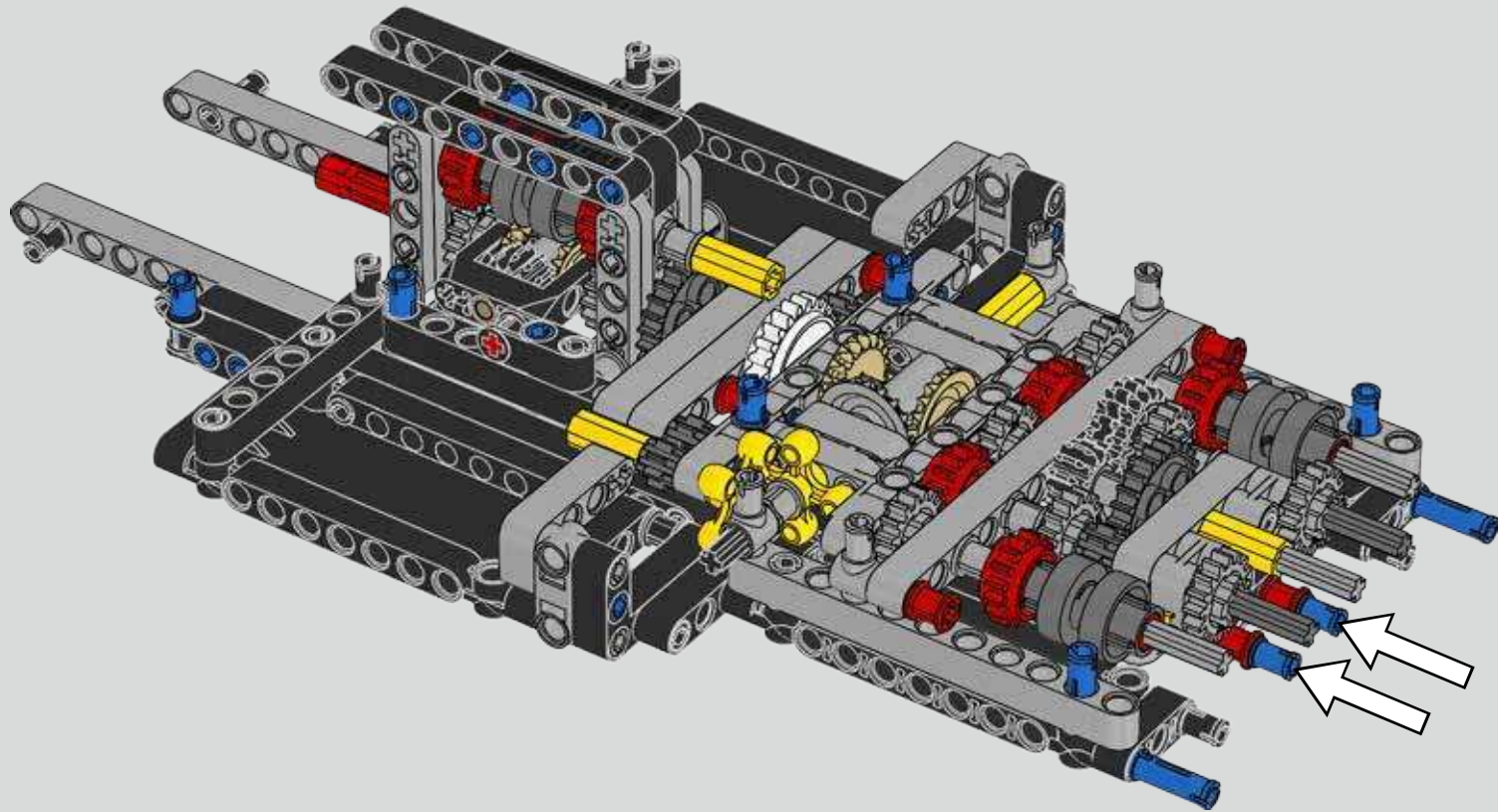

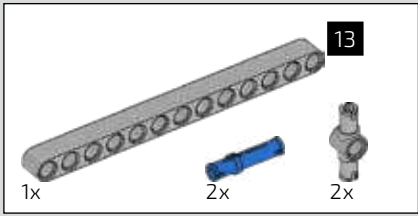

98

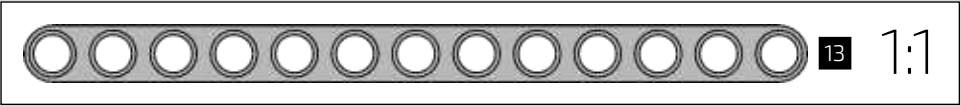
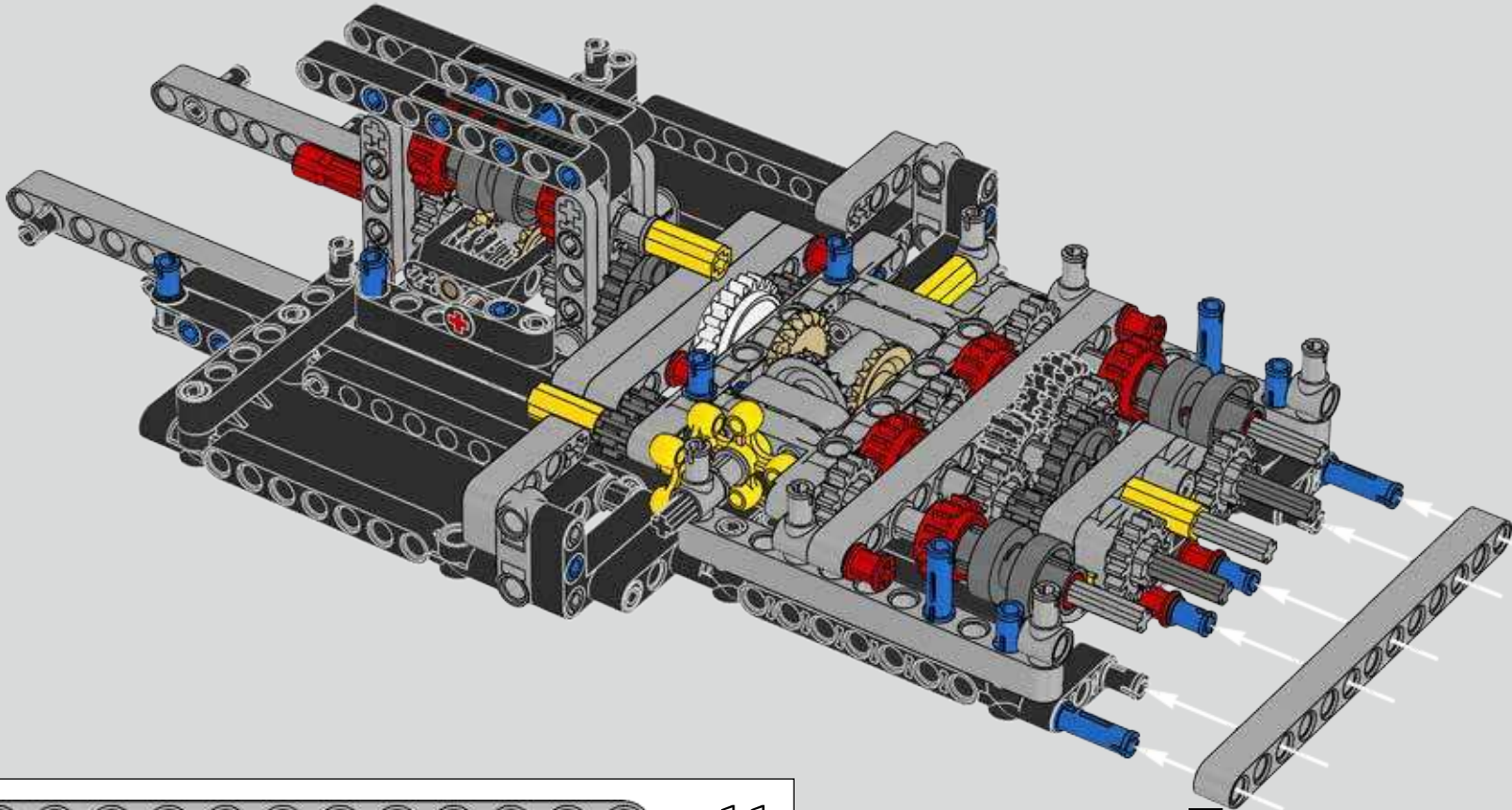

13

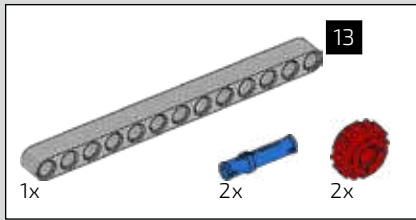

99

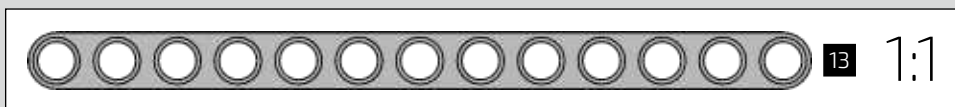
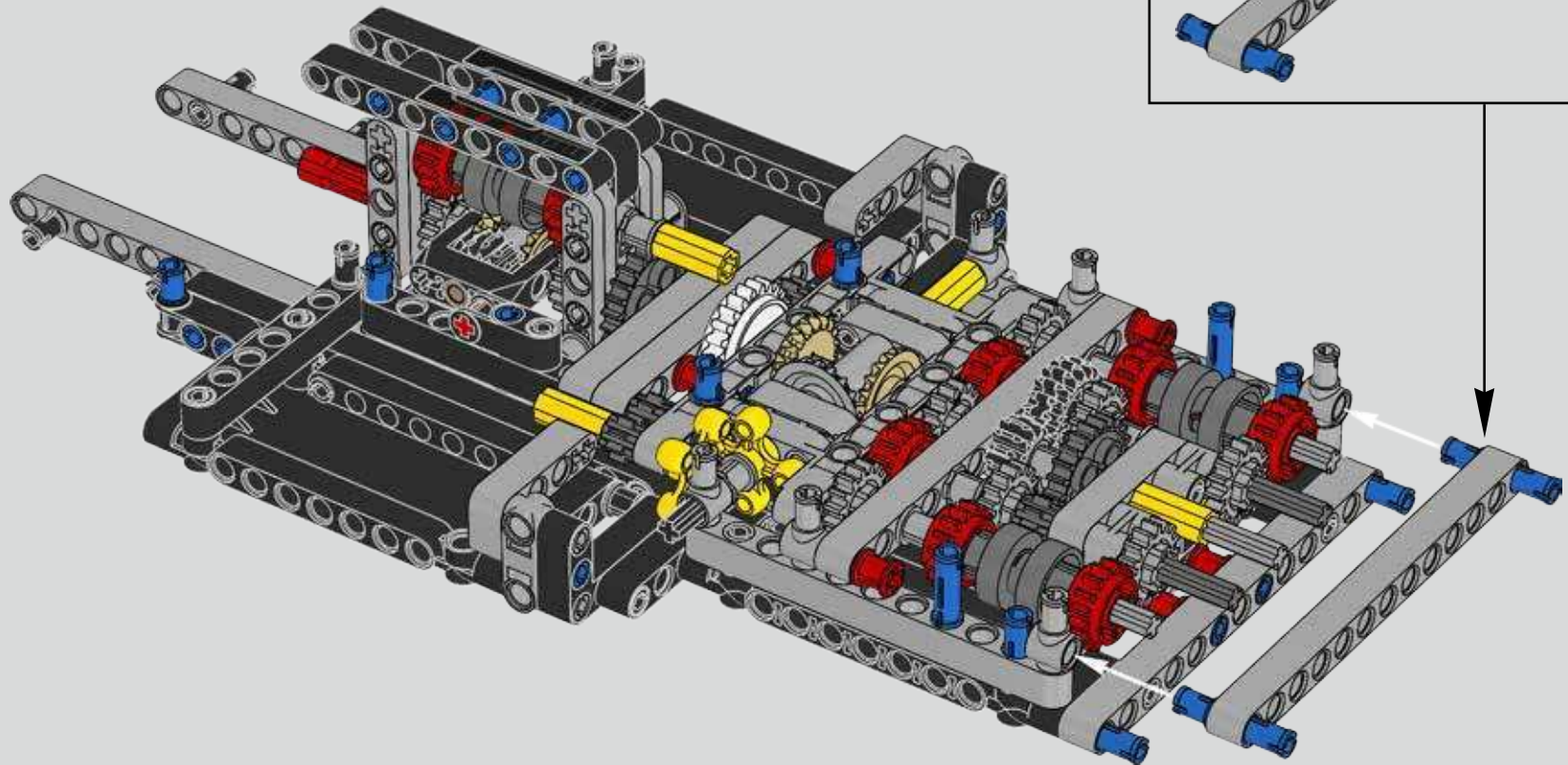
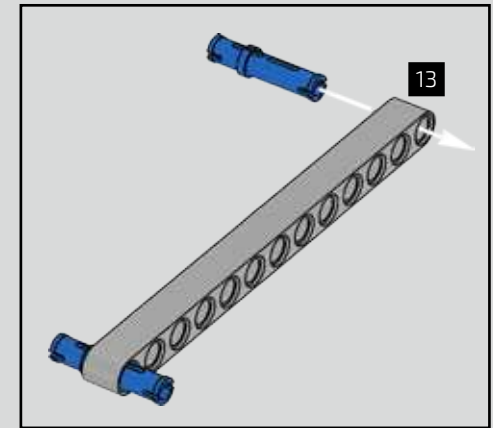

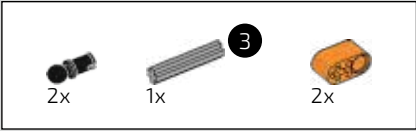

100

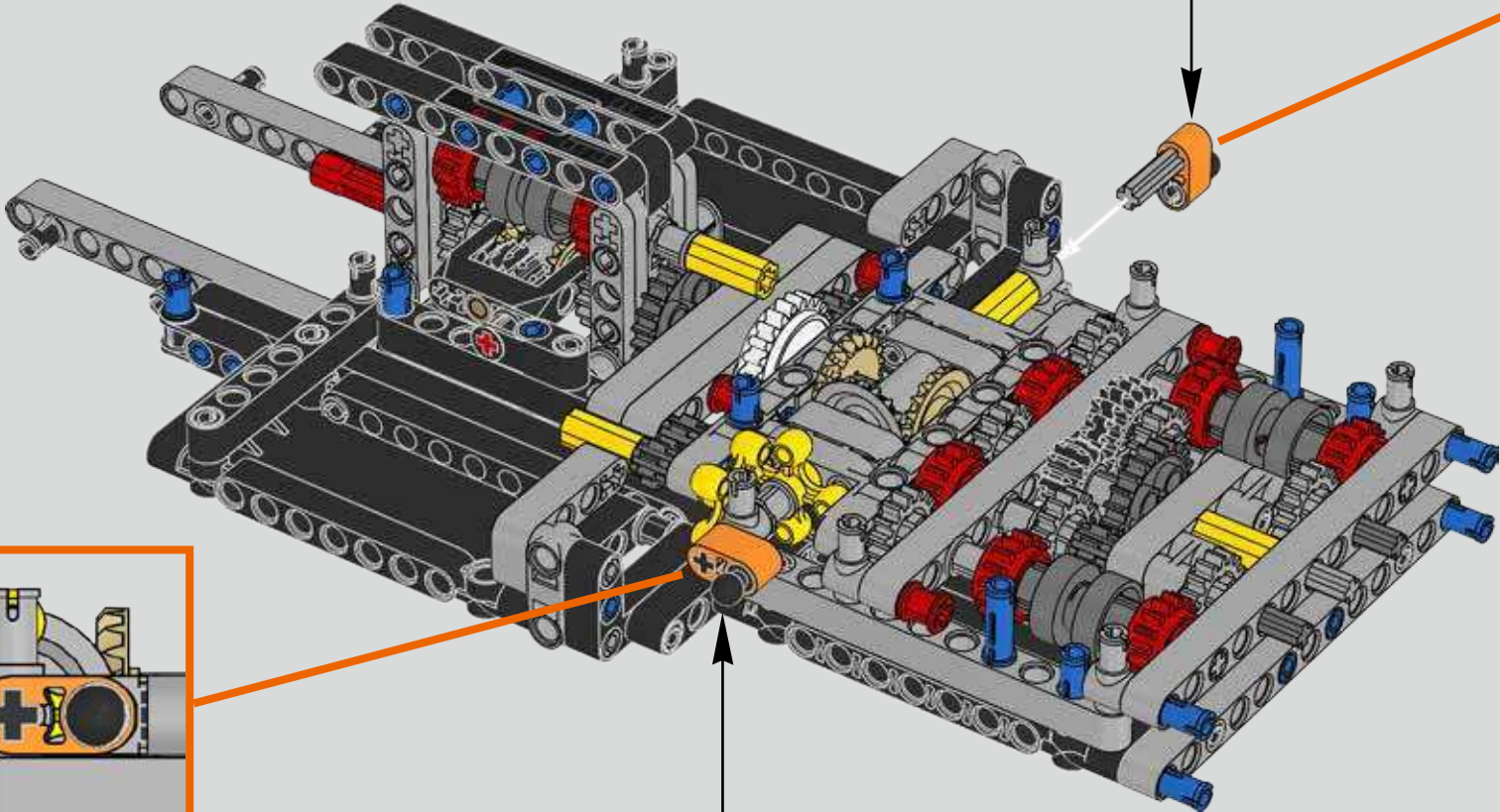
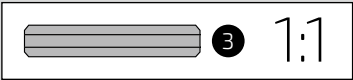
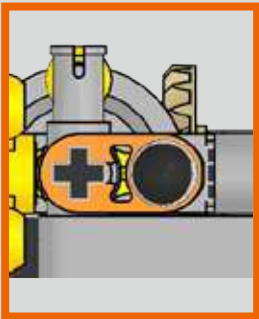
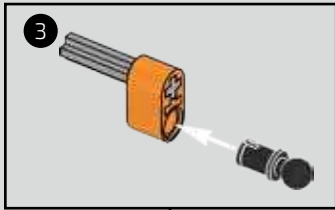

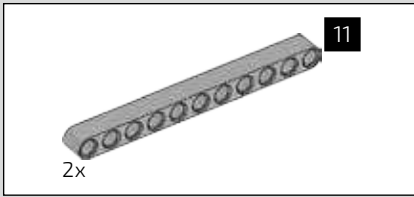

101

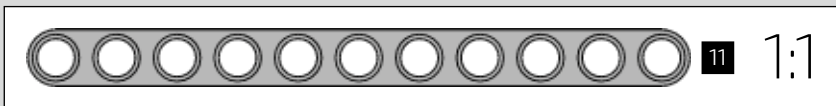
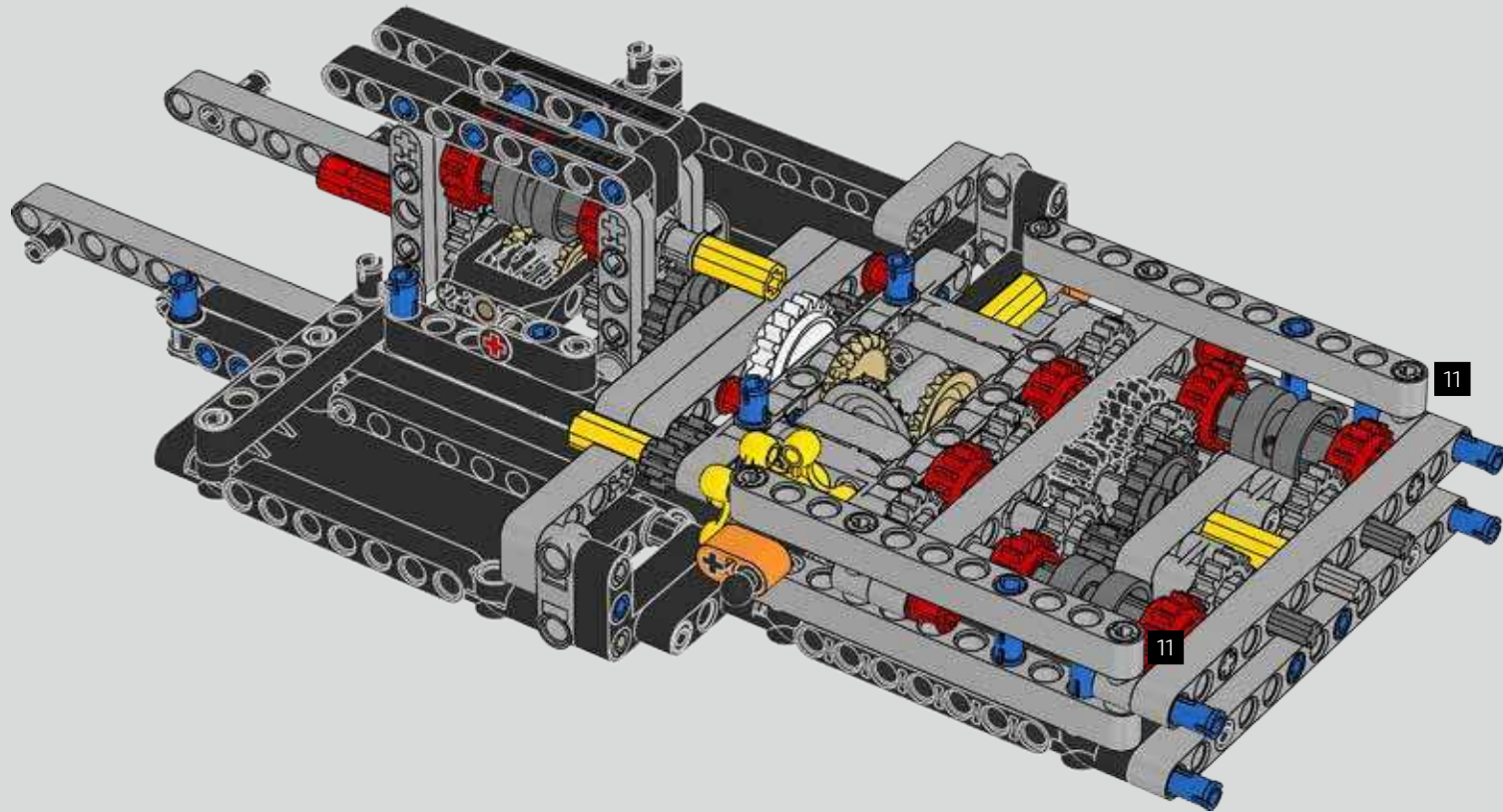

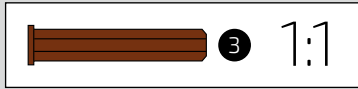
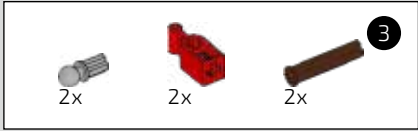

102

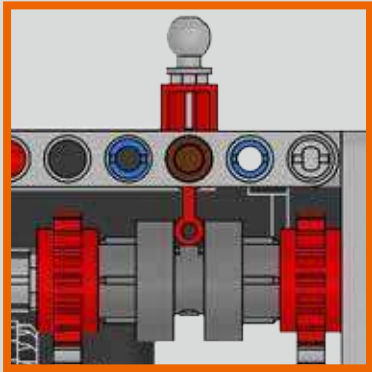
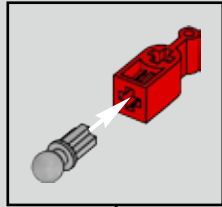
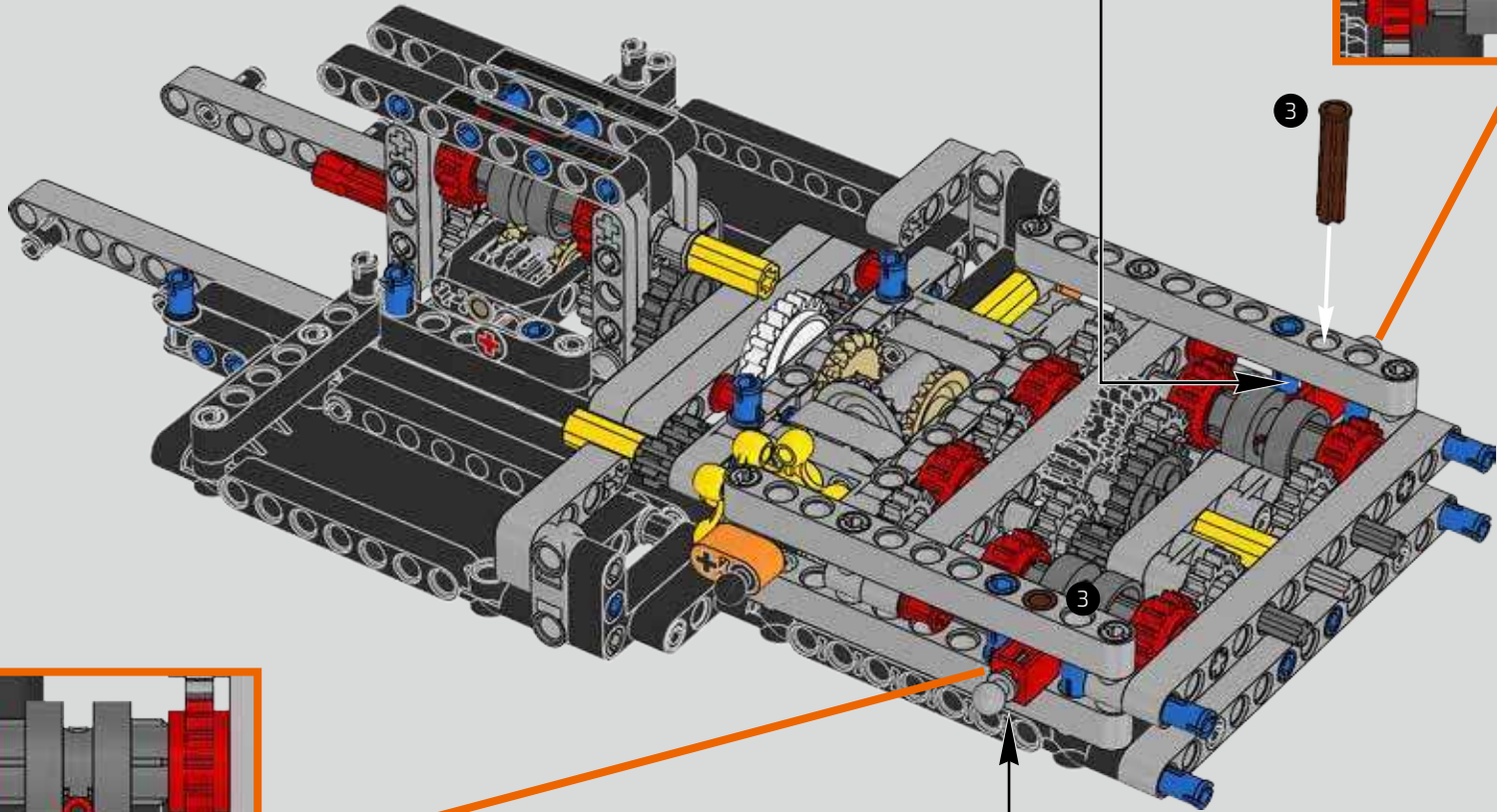

3

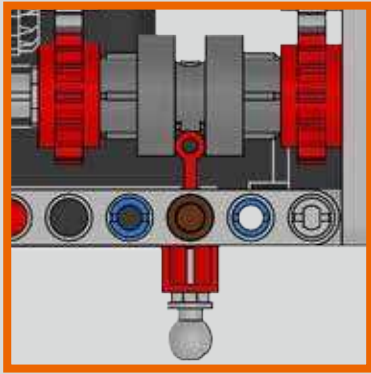
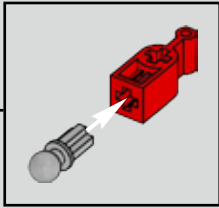

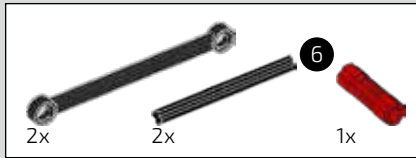

103

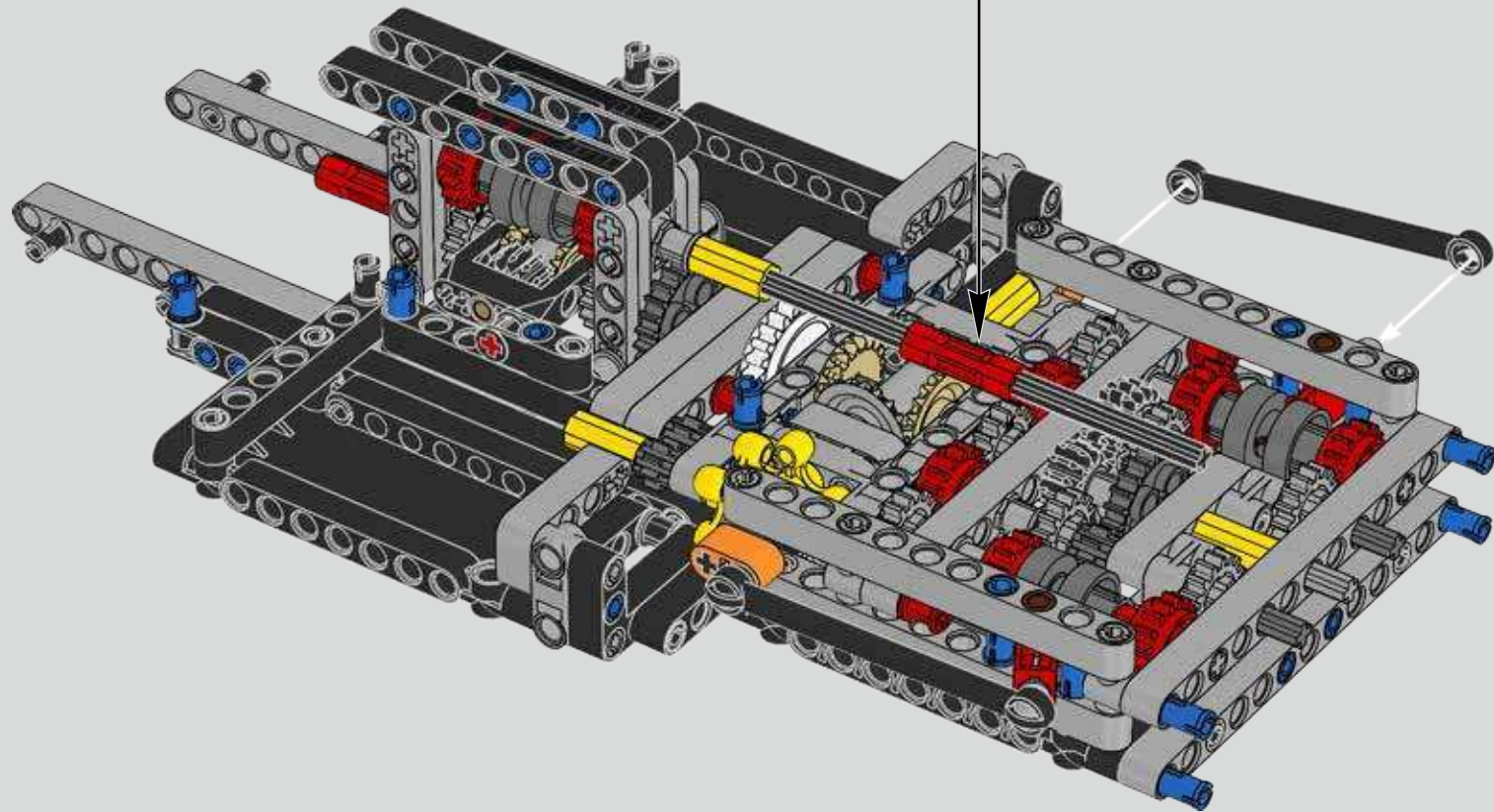
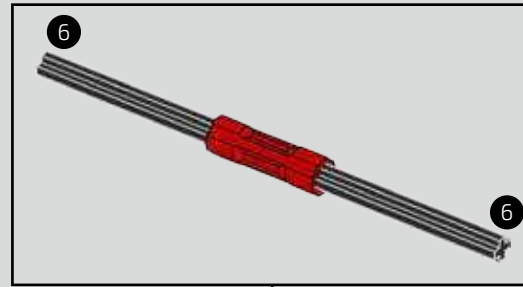

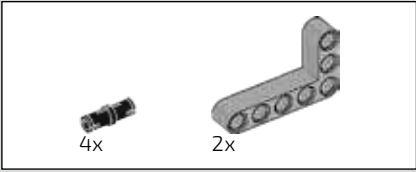

104

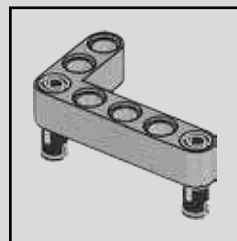
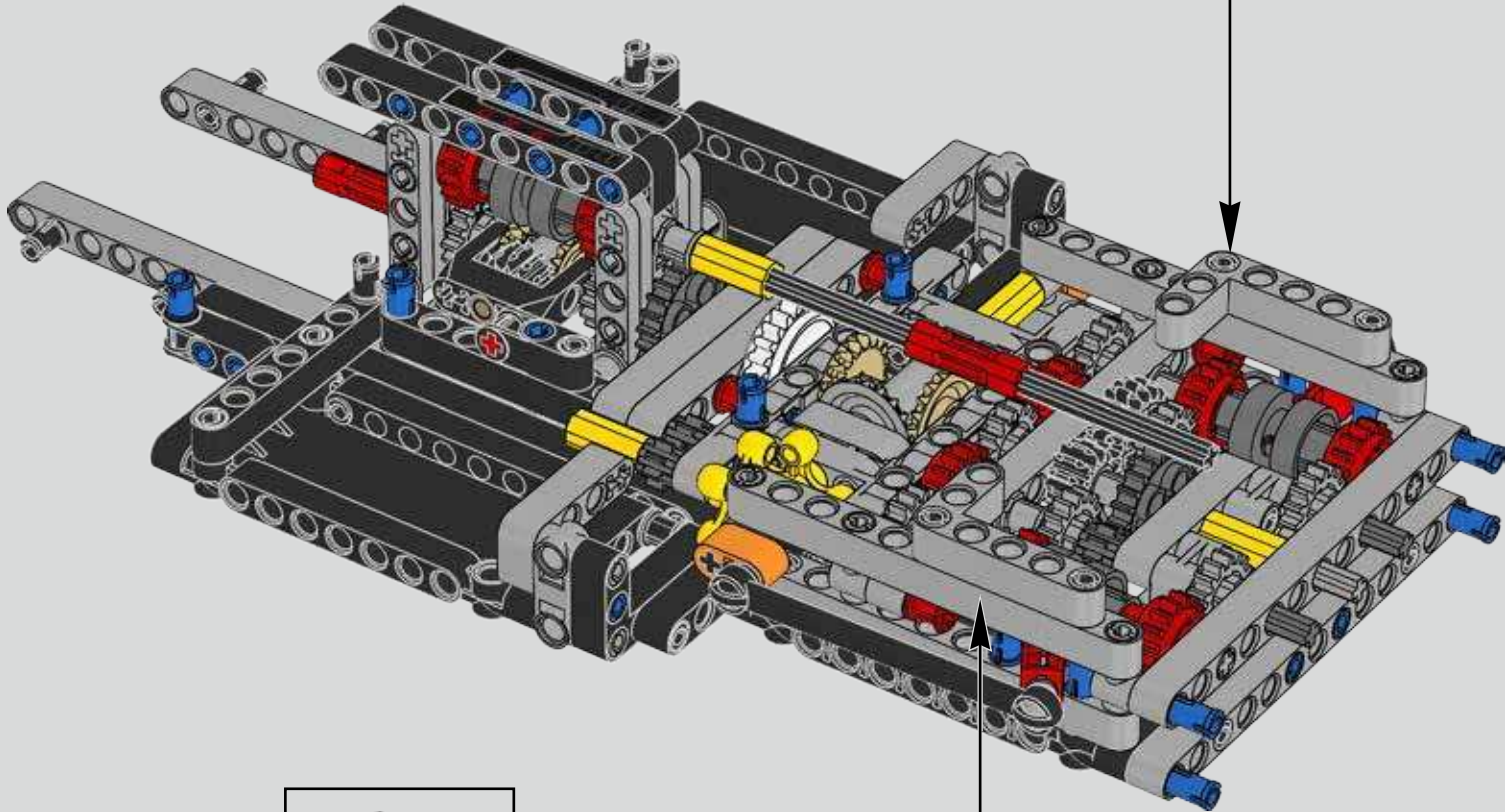
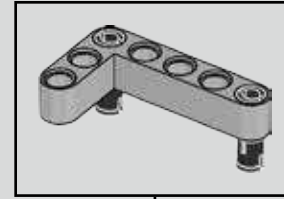



105

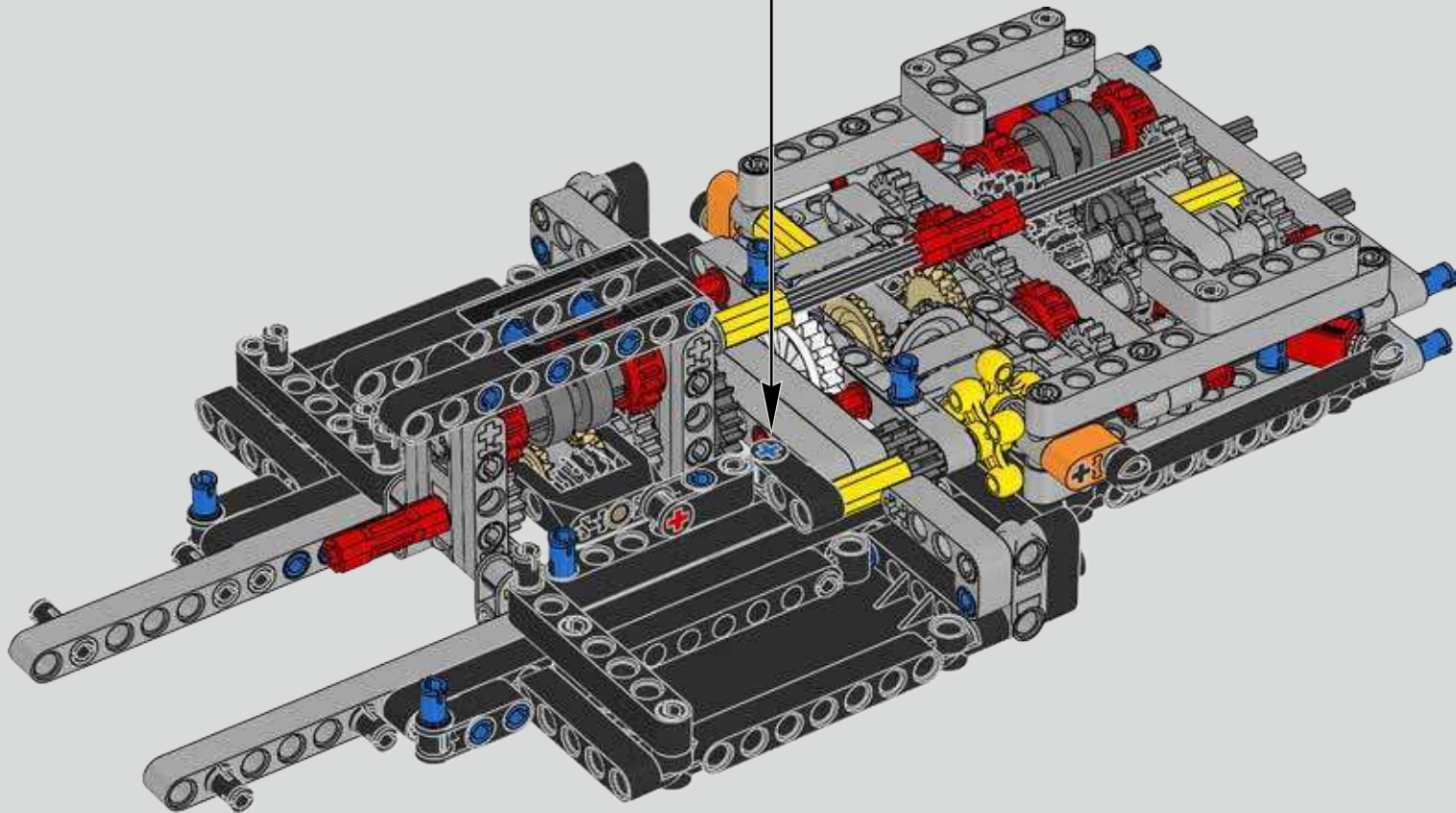

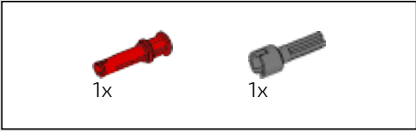

106

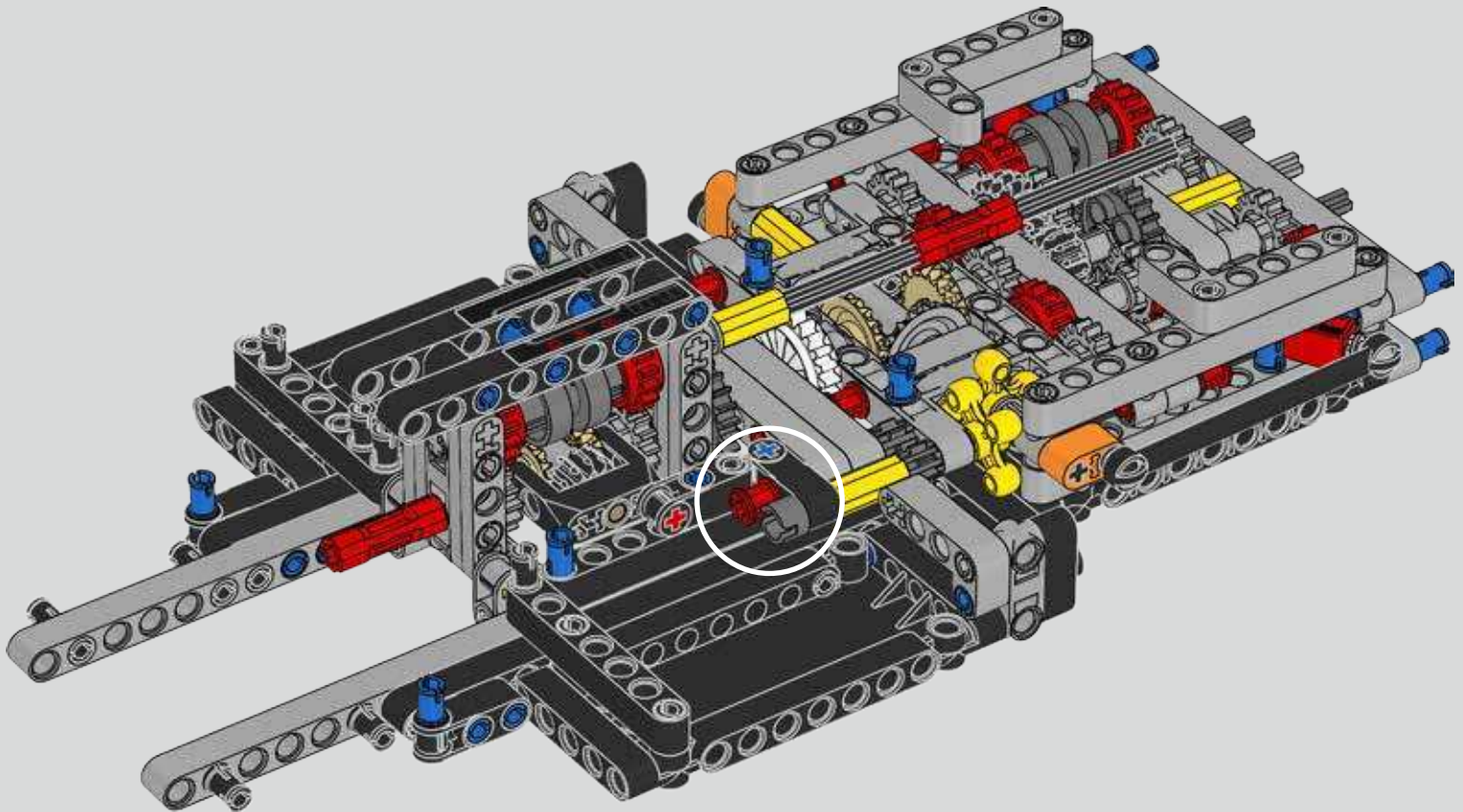

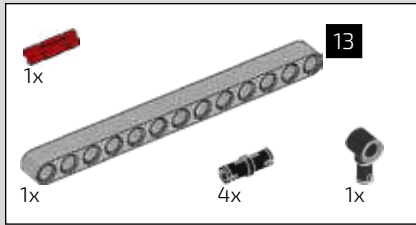

107

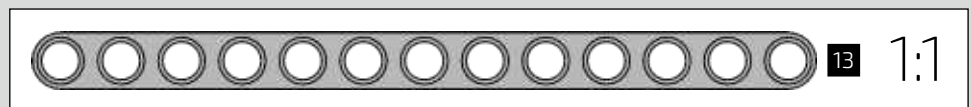
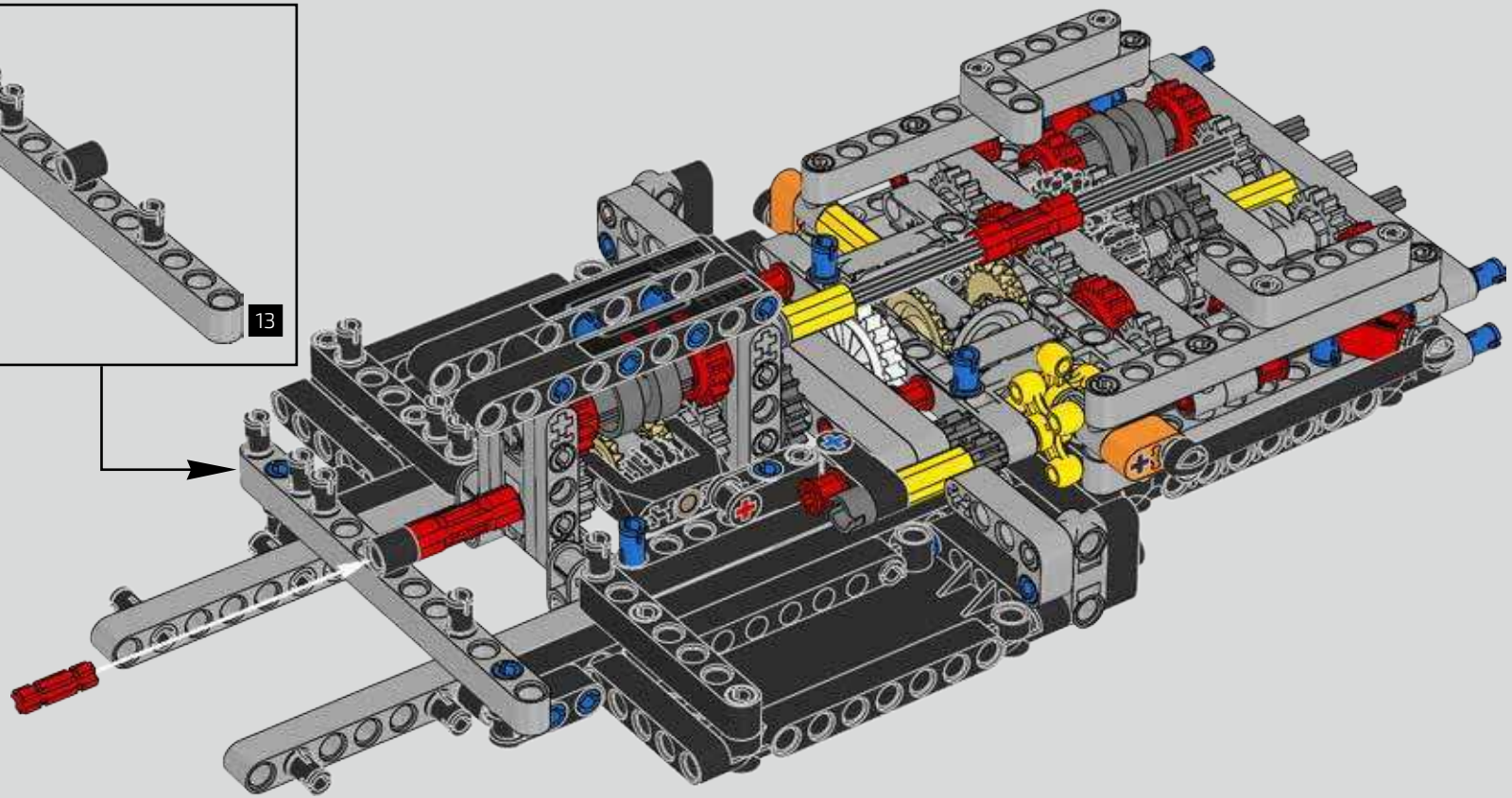
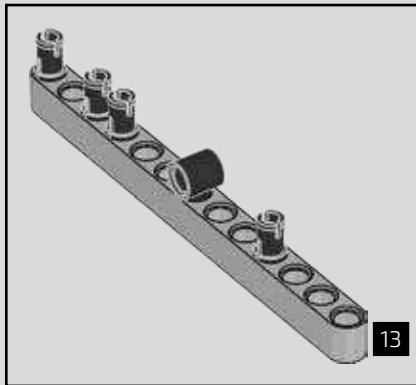

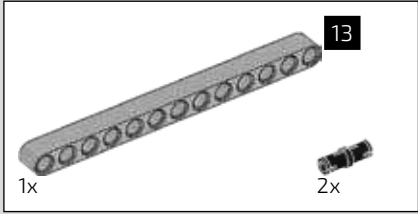
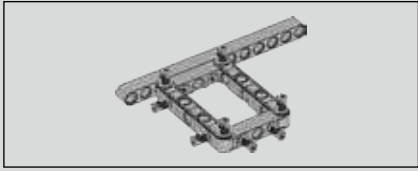

108

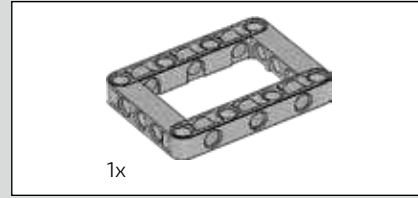
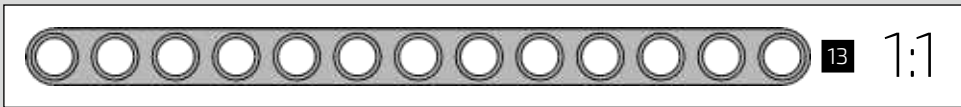
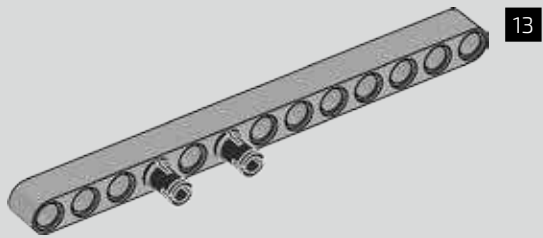

109

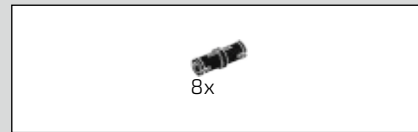
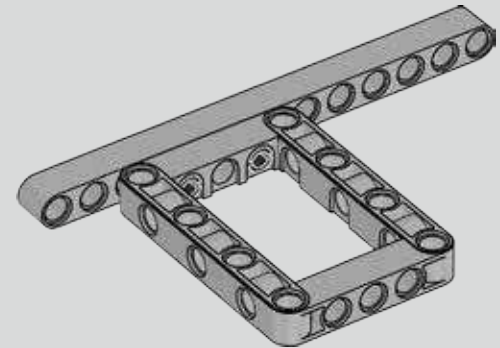

110

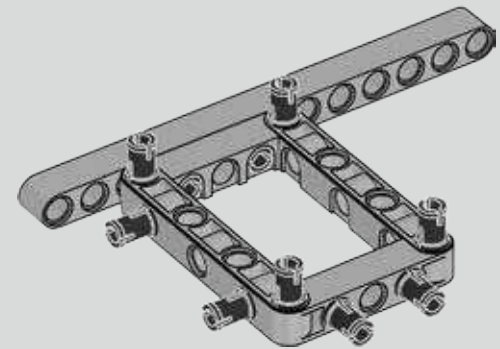

111

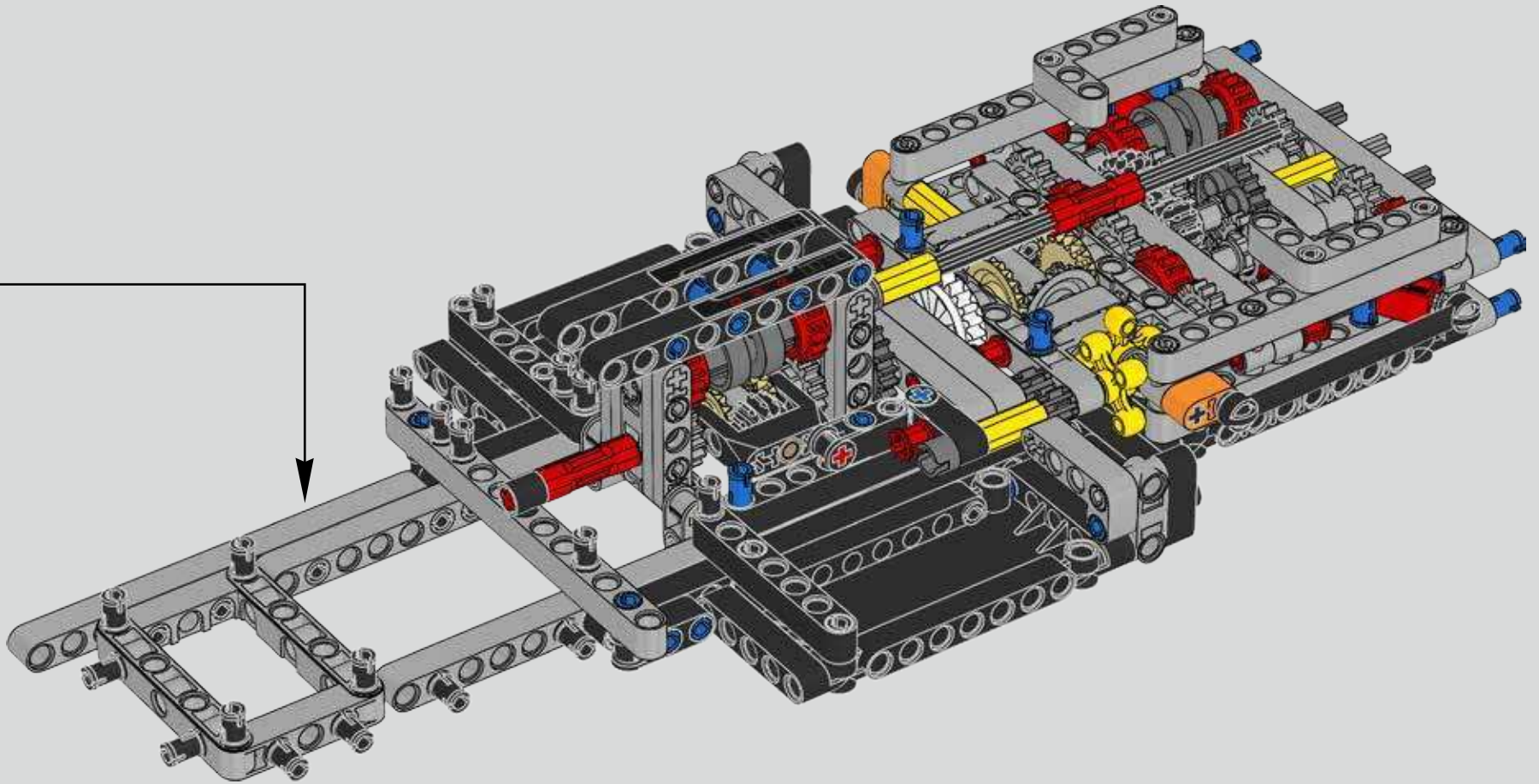

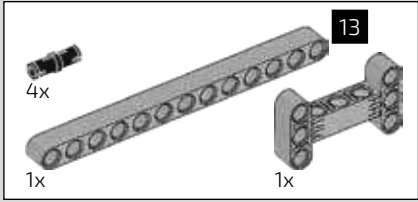

112

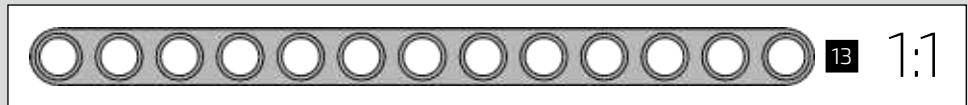
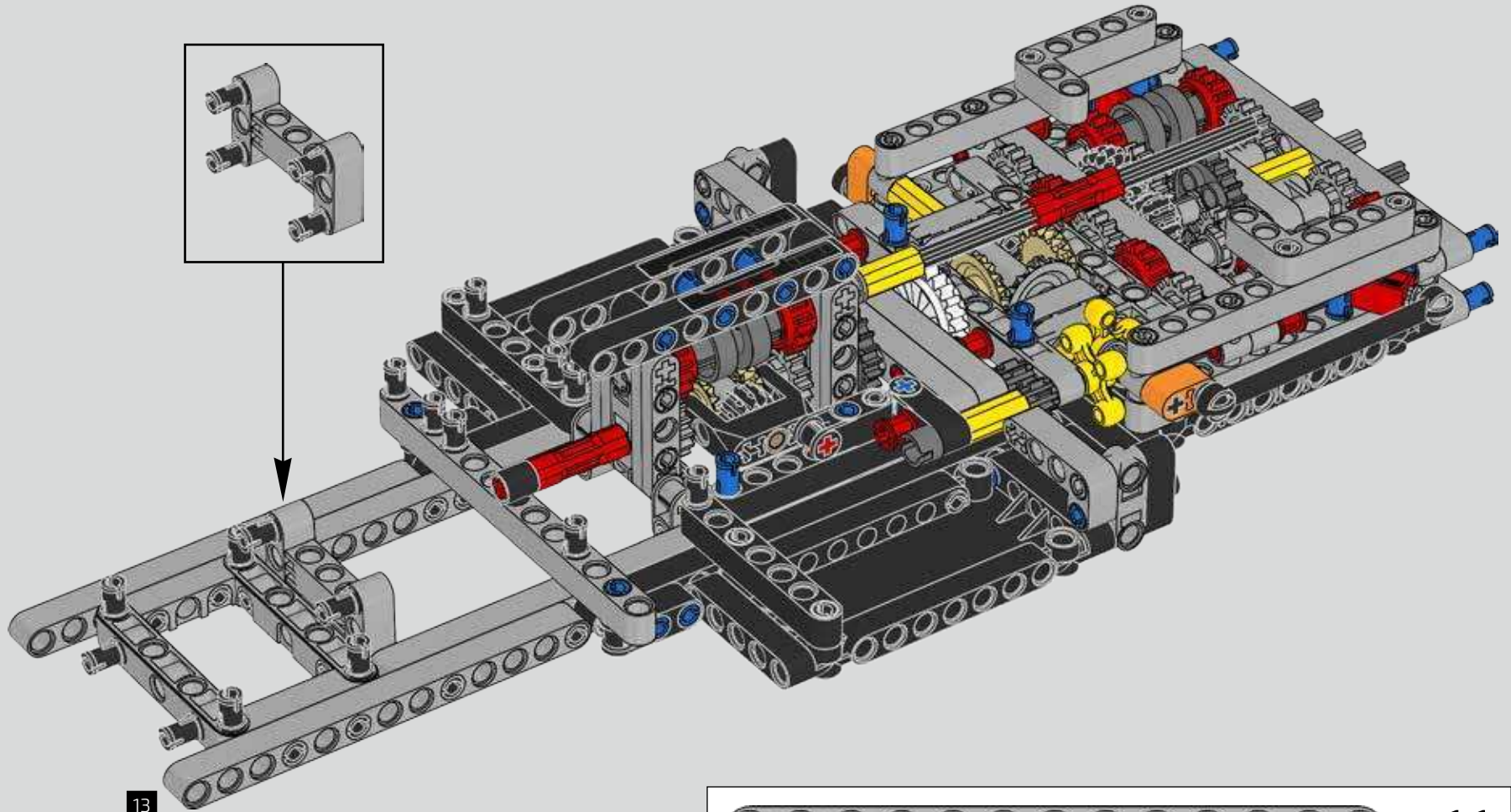
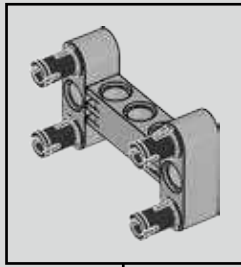

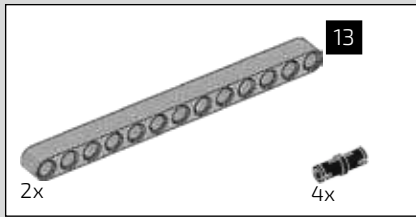

113

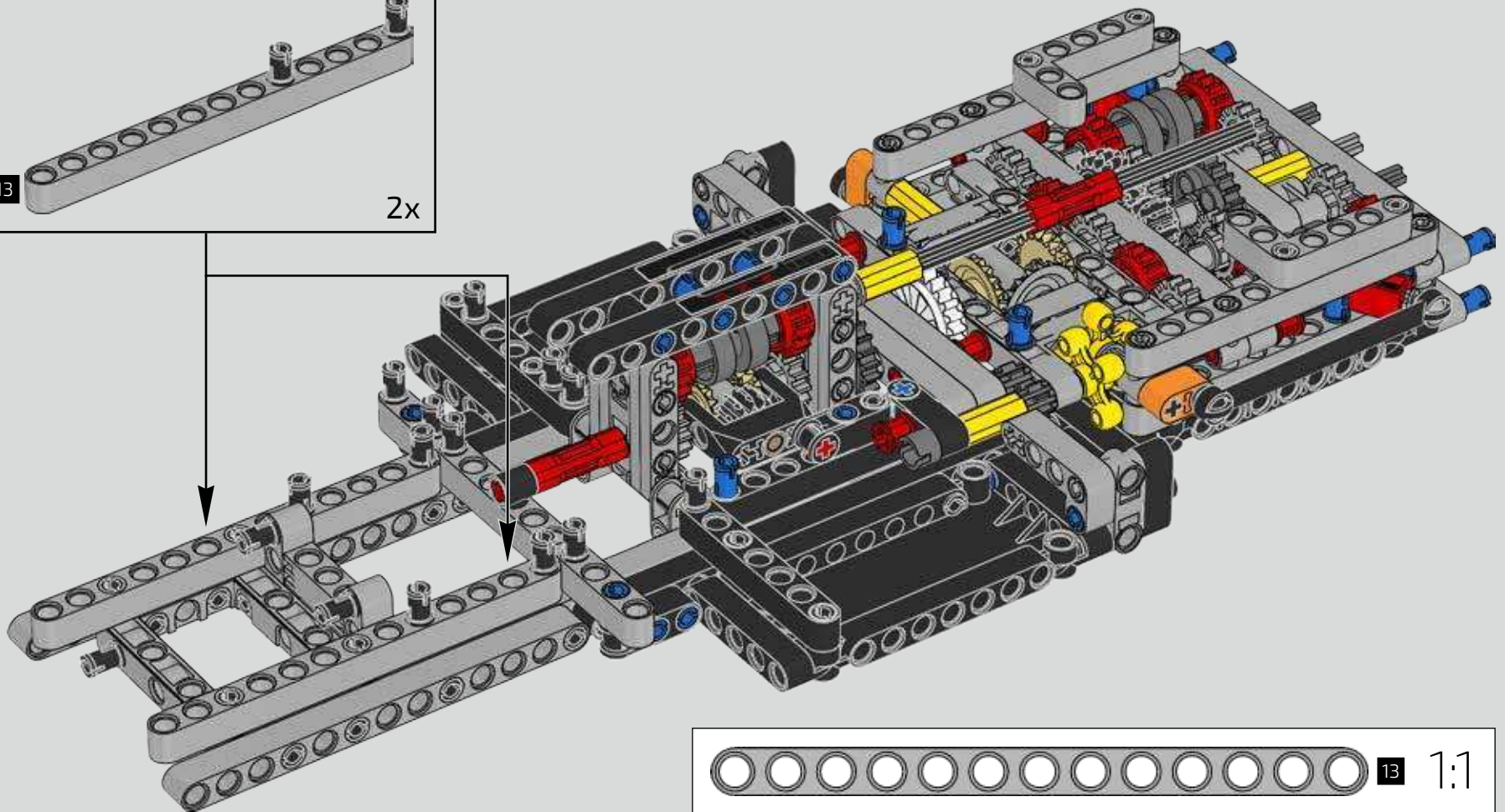
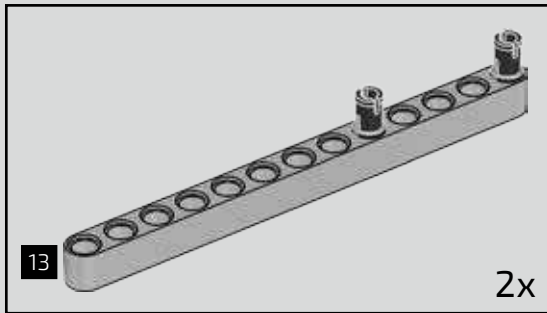

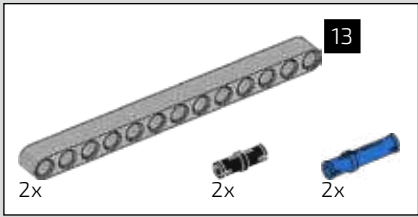

114

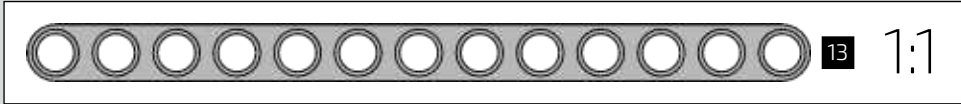
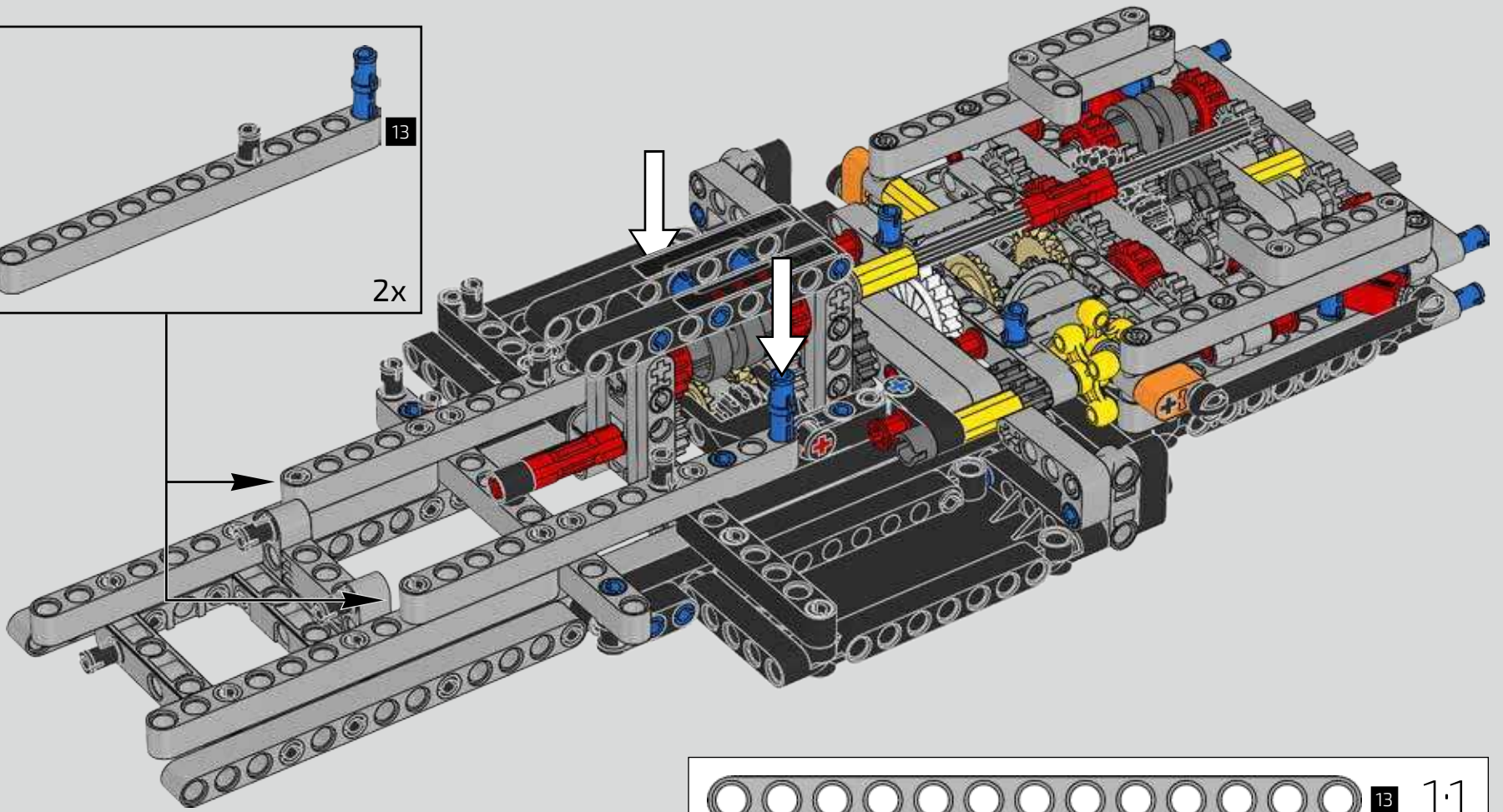
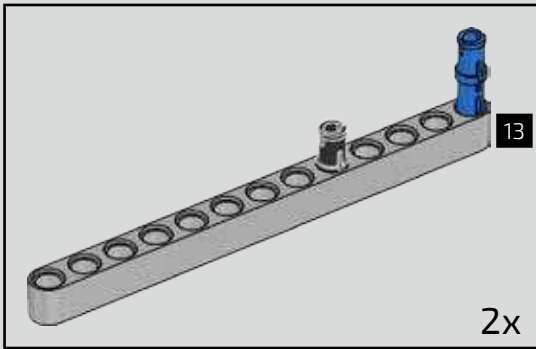

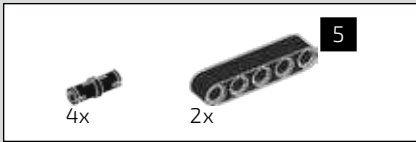

115

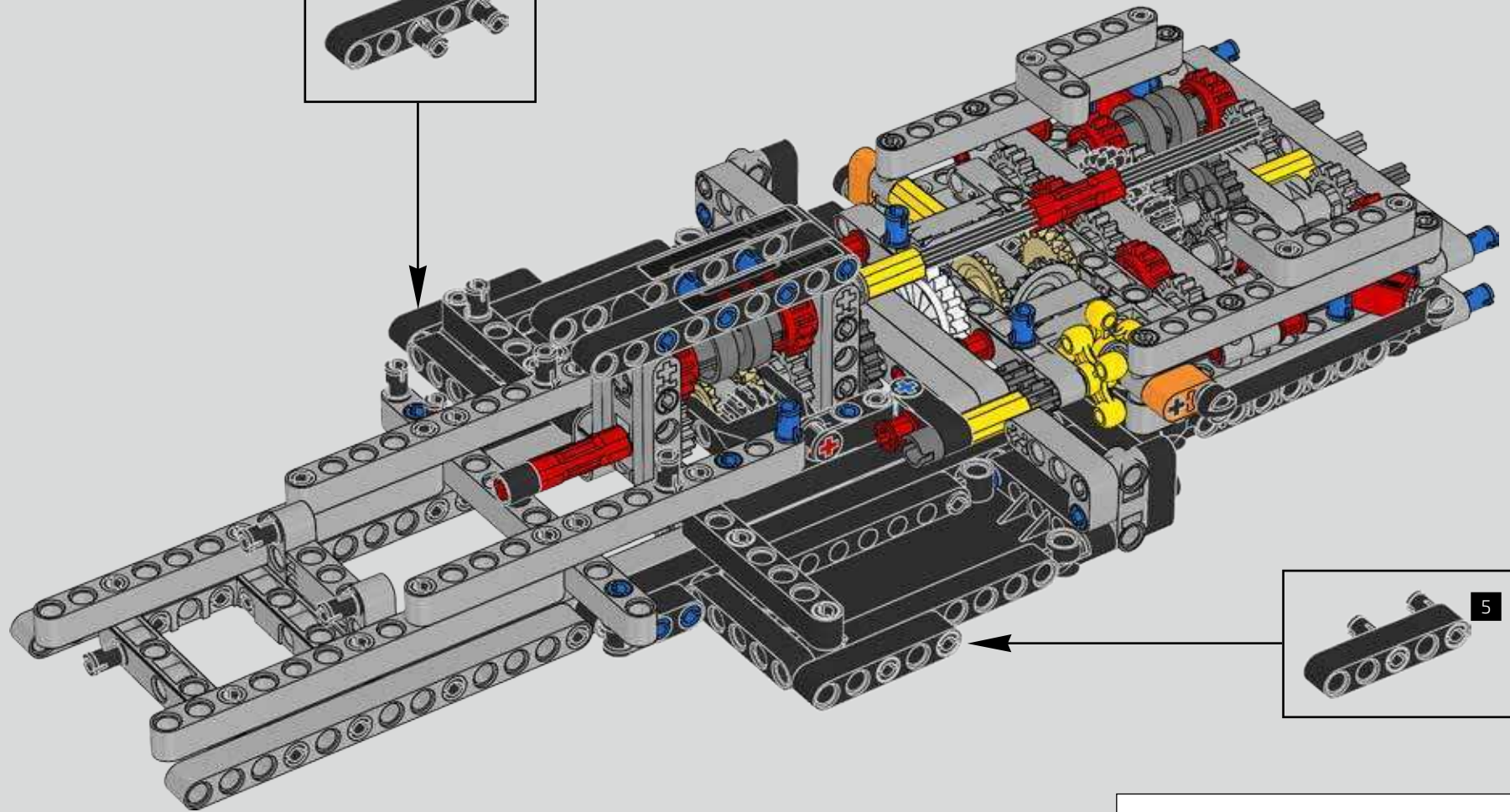
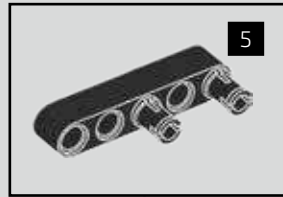

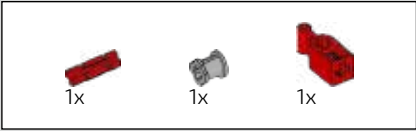

116

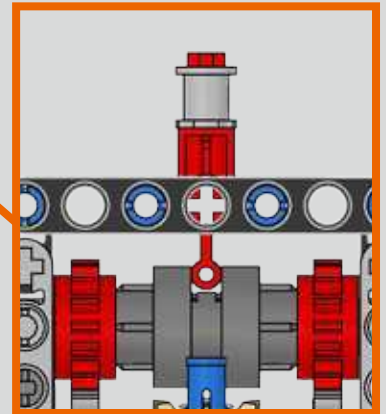
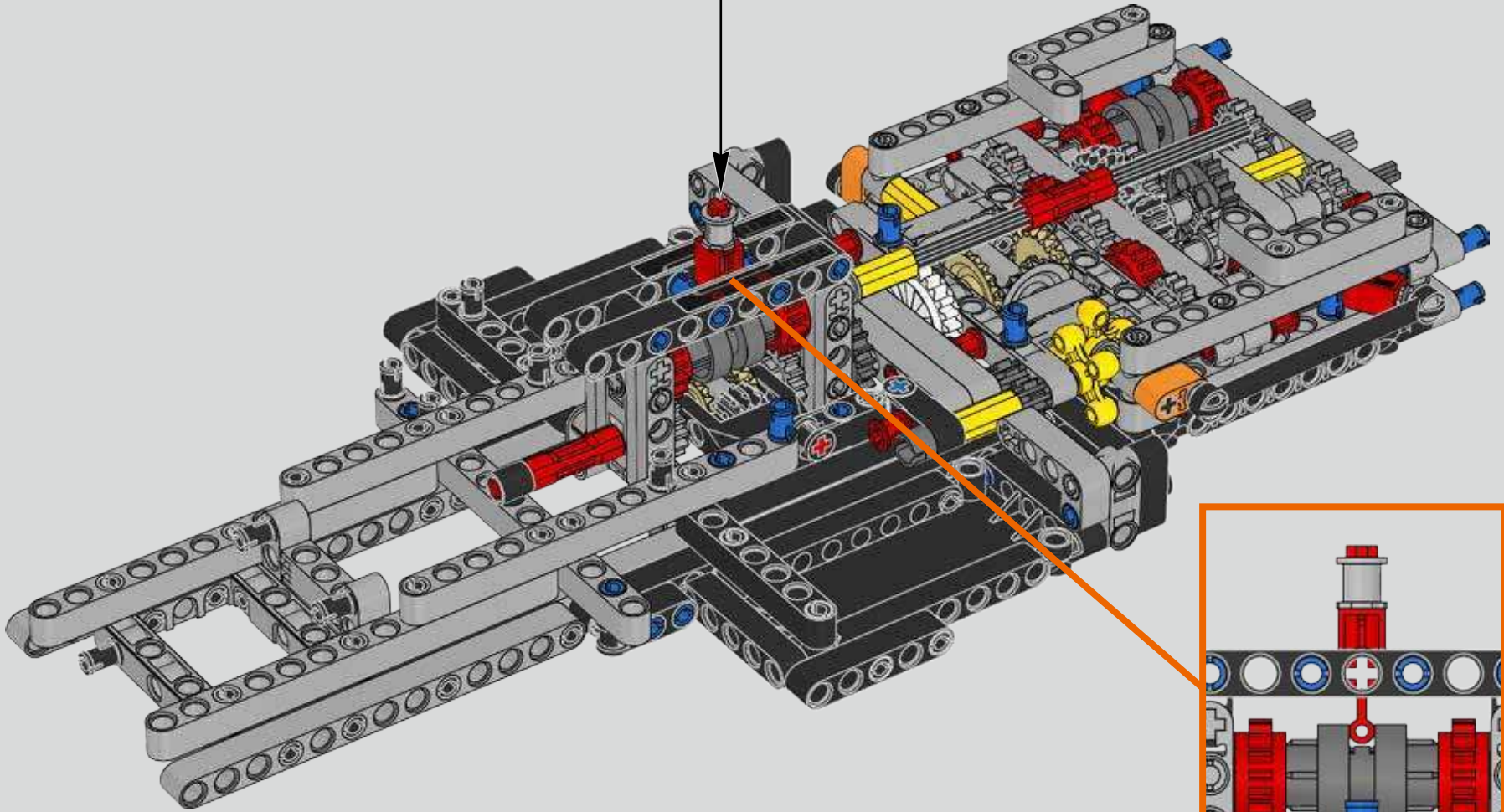
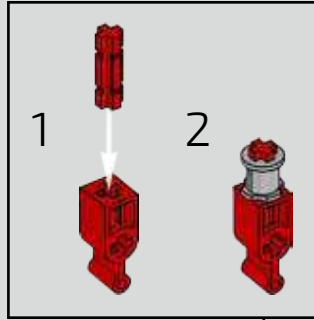

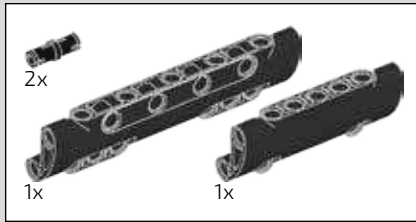

117

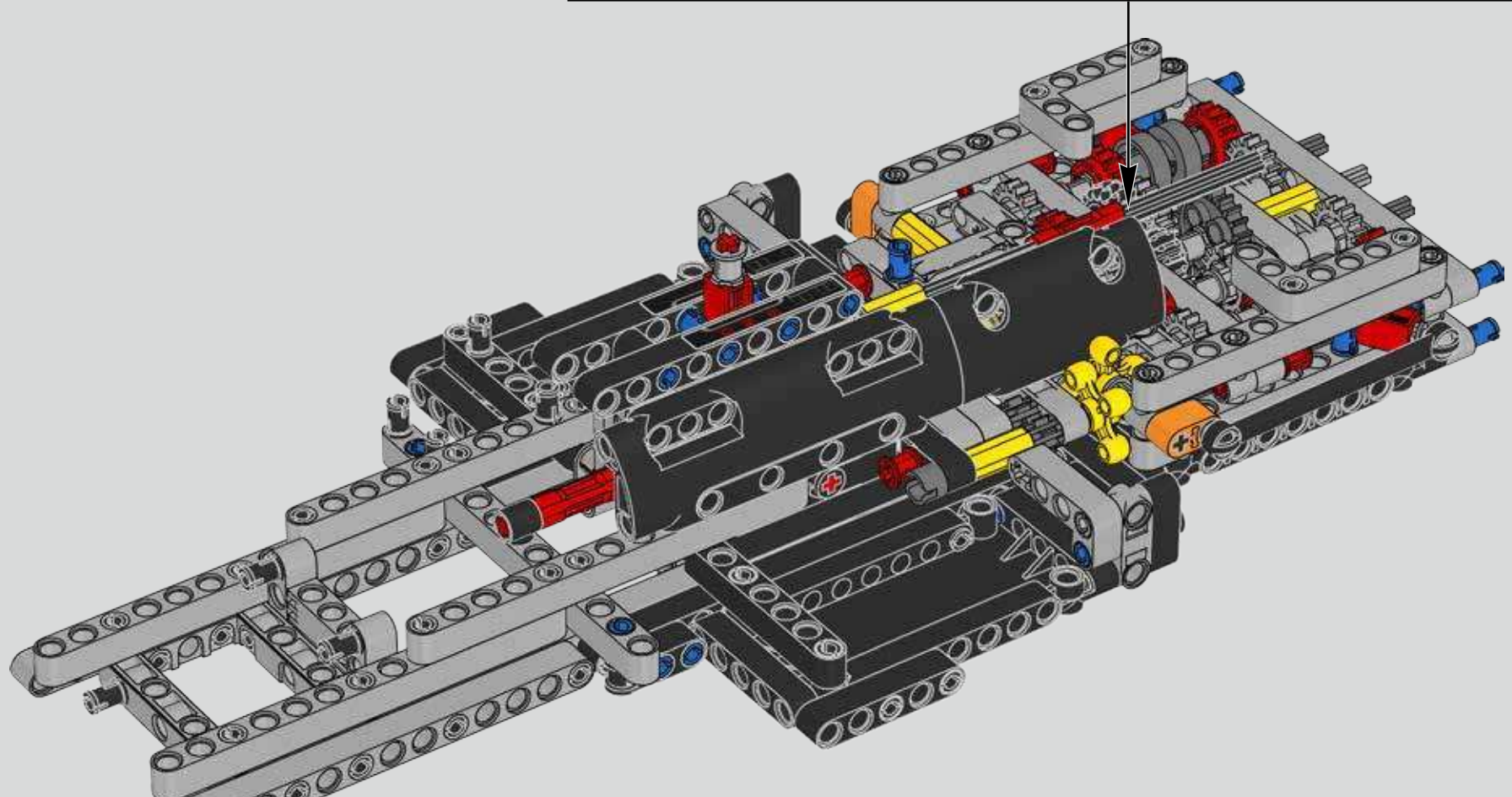
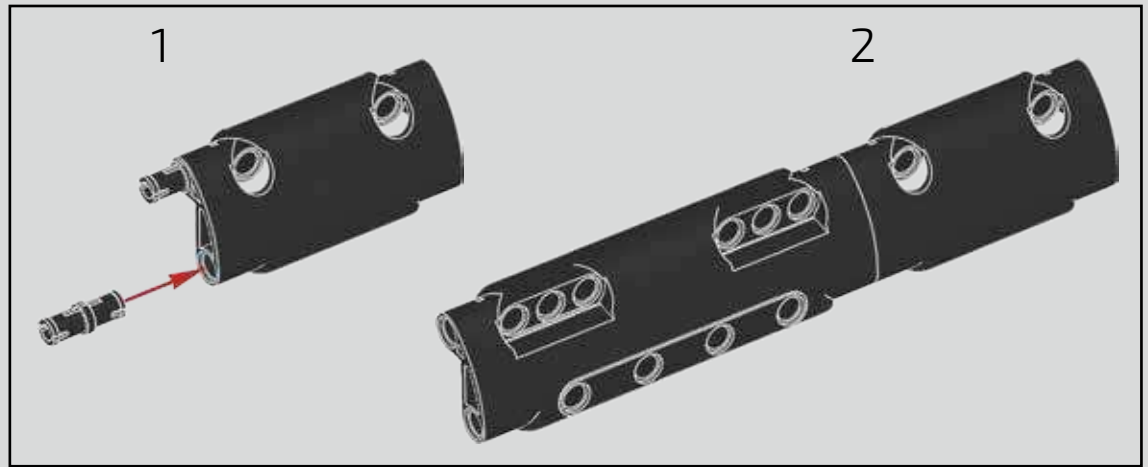

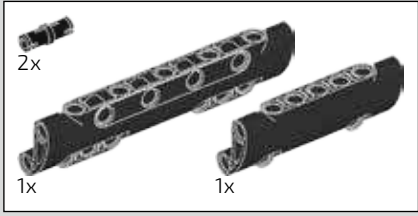

118

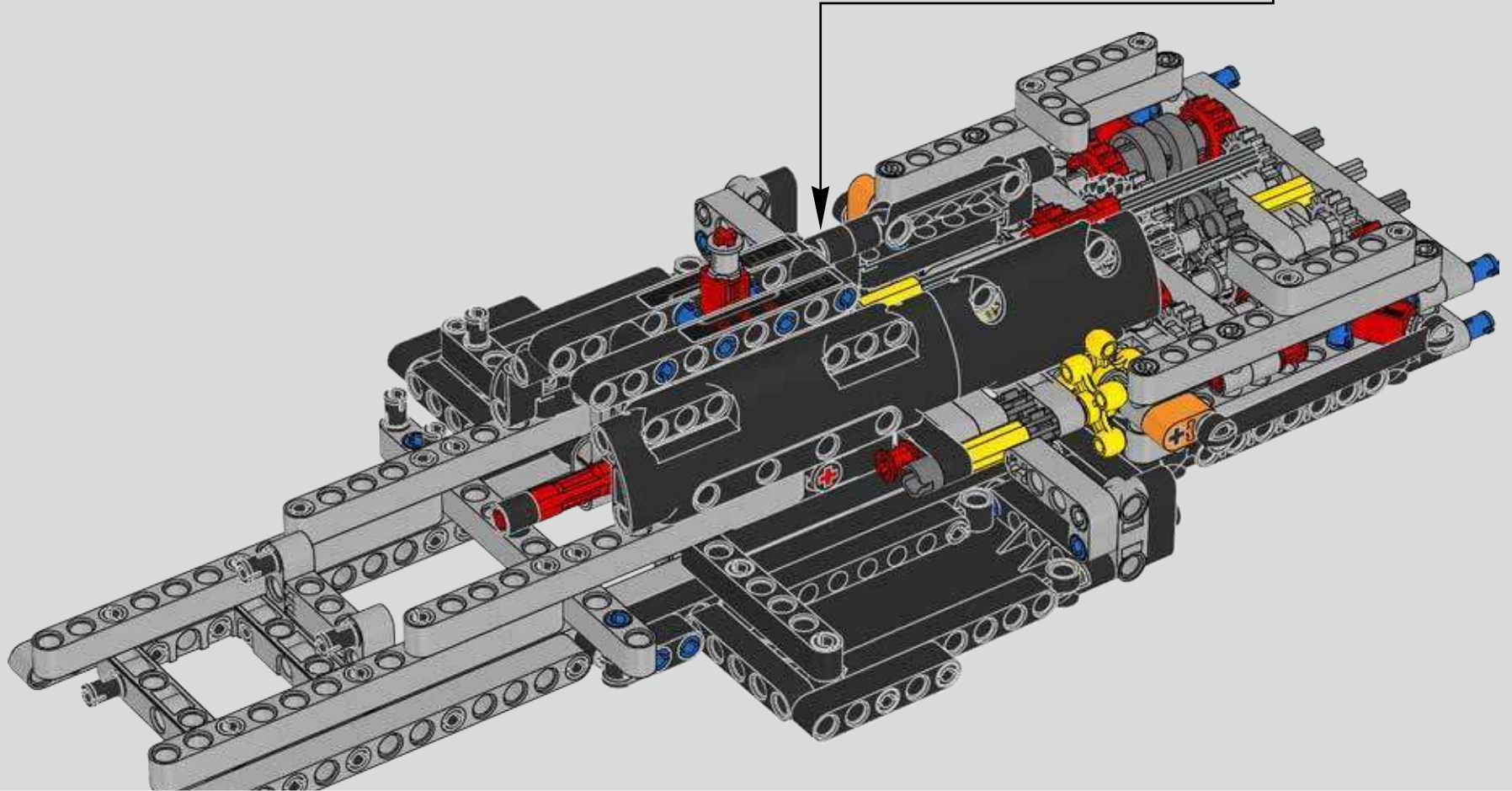
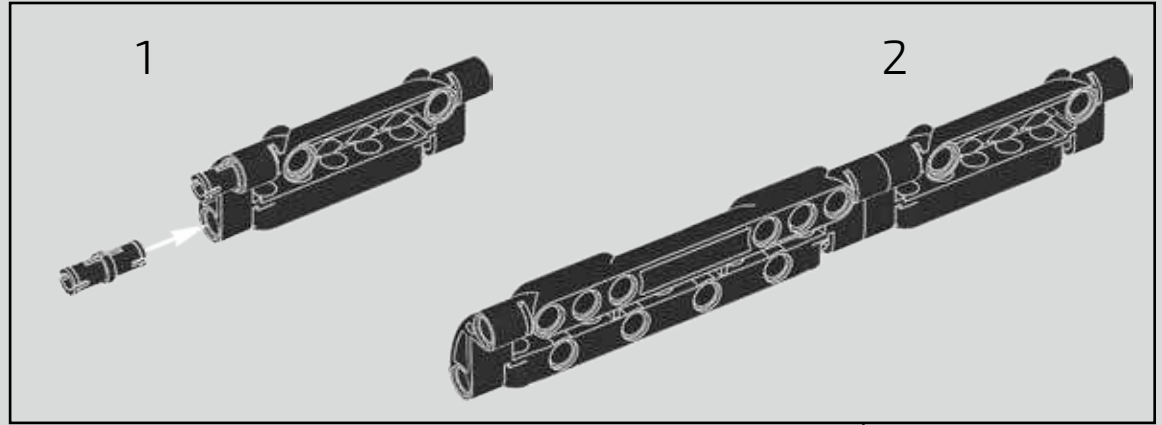

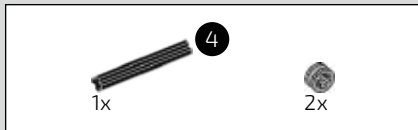

119

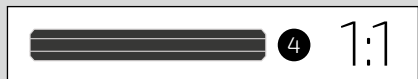
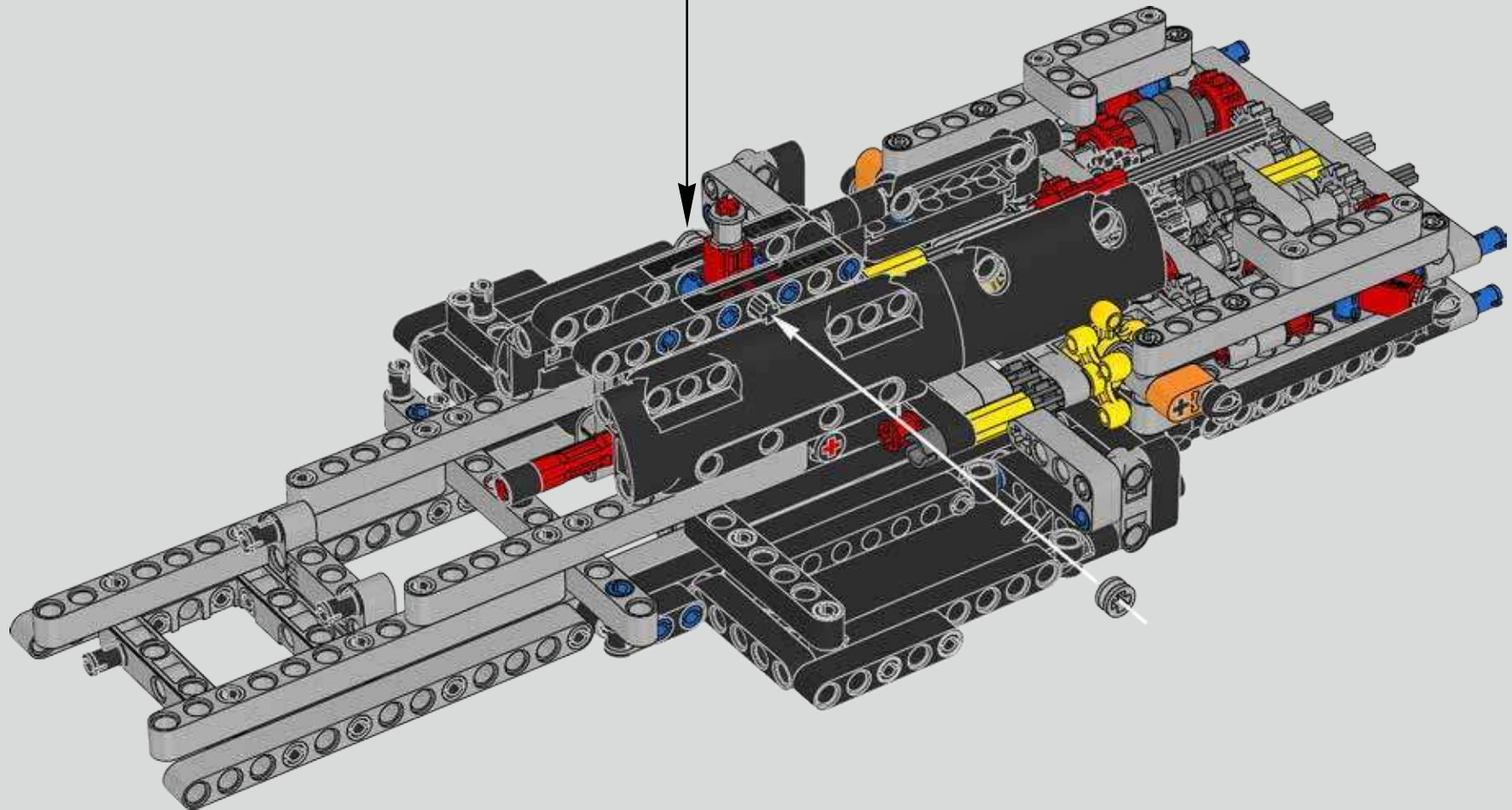
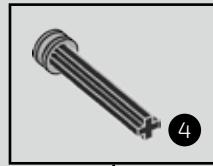

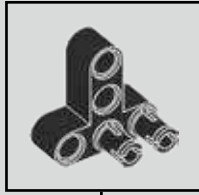
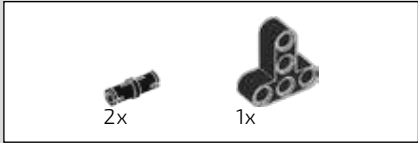

120

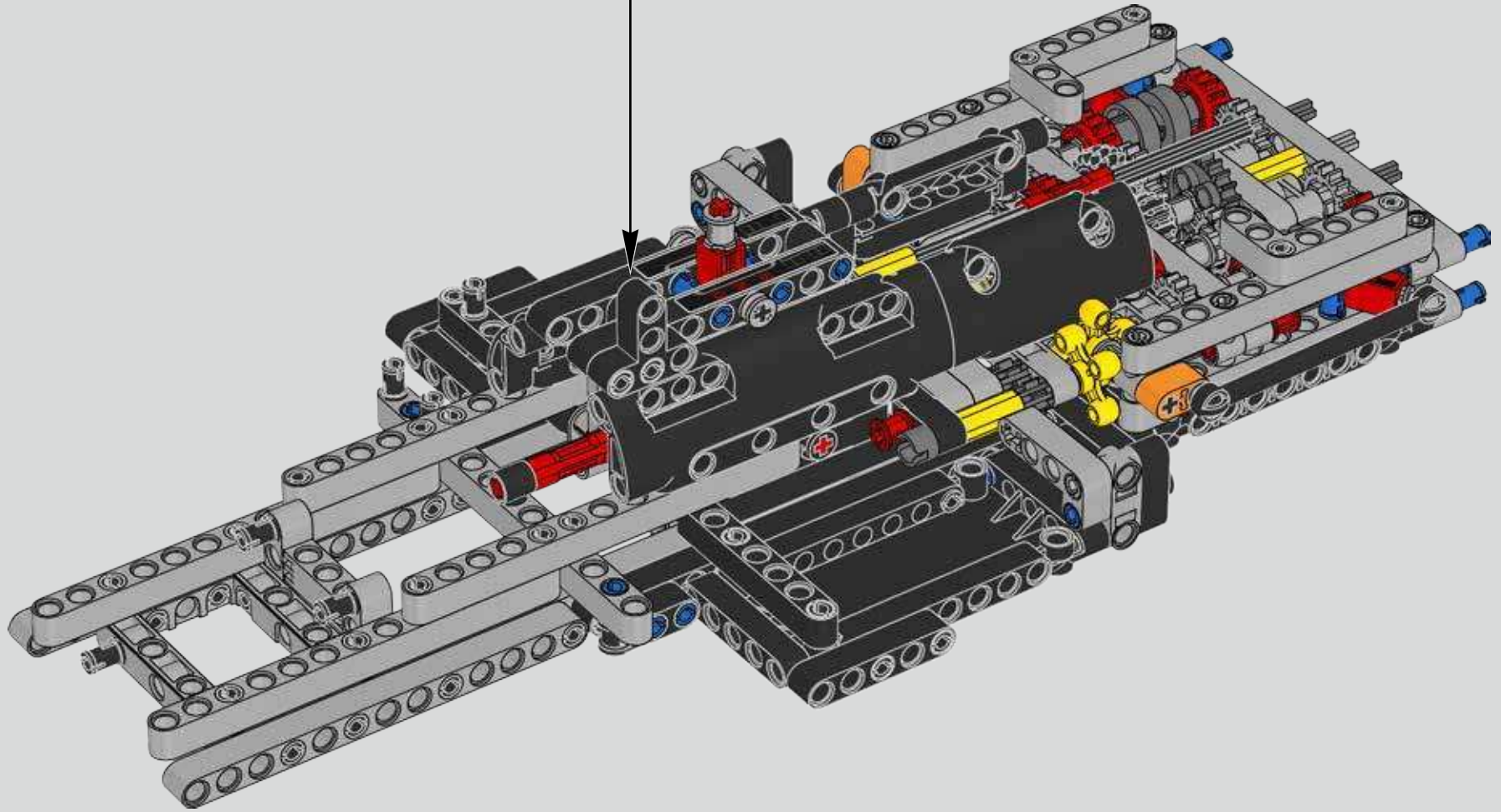

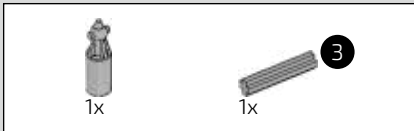

121

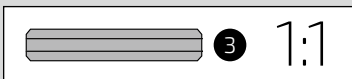
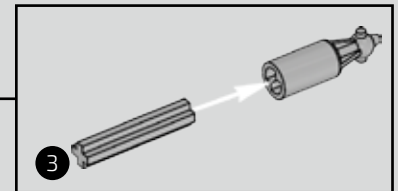
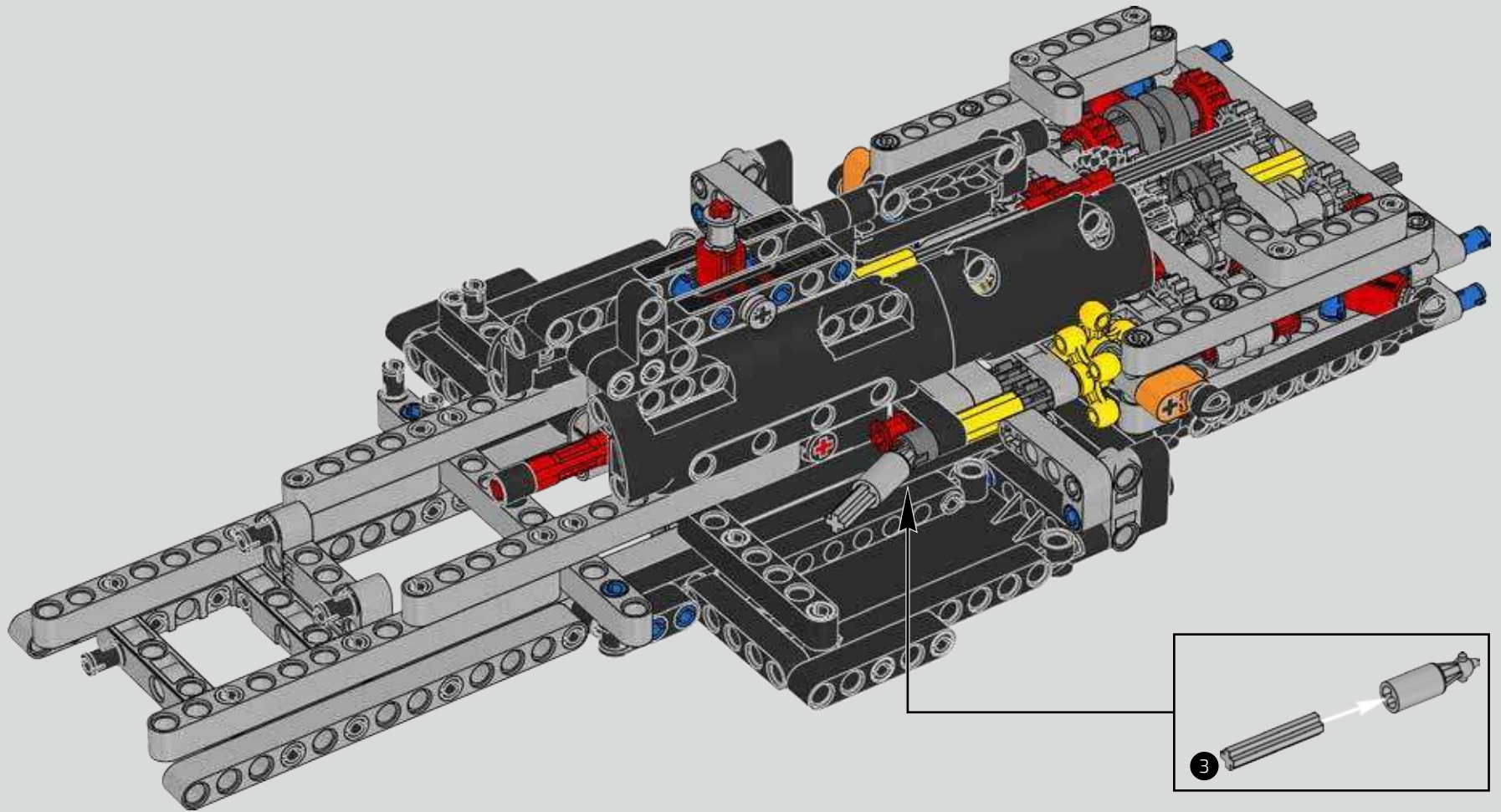

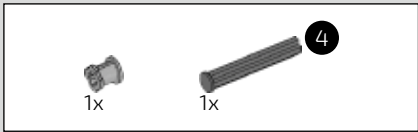
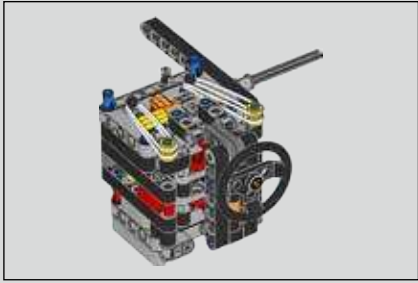

122

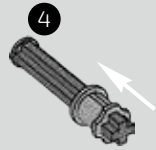

123

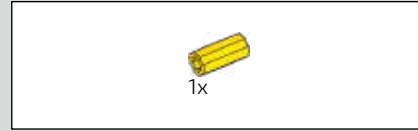
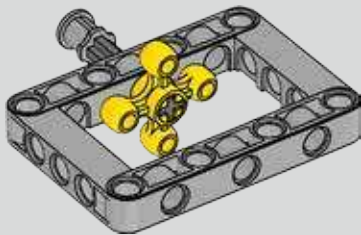

124

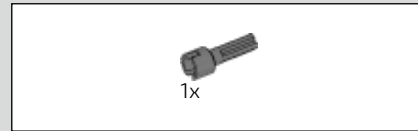
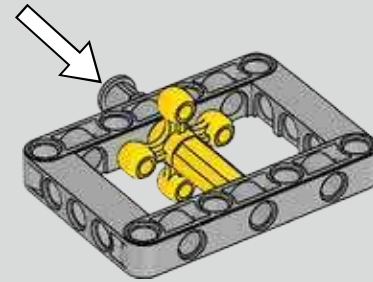

125

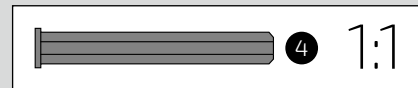
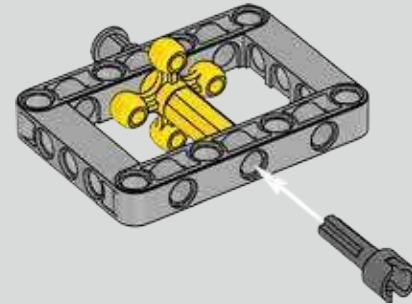

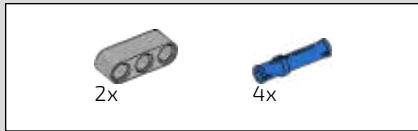

126

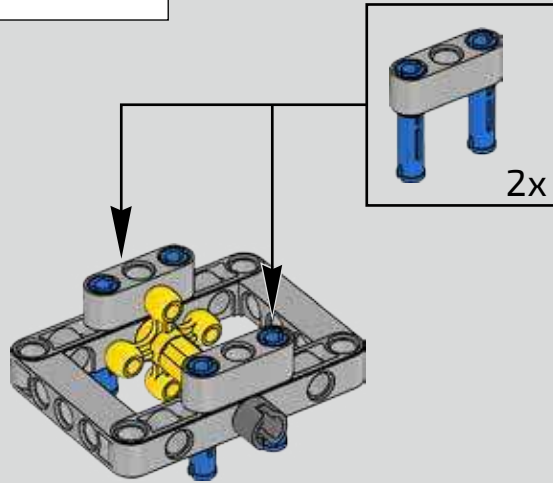

127

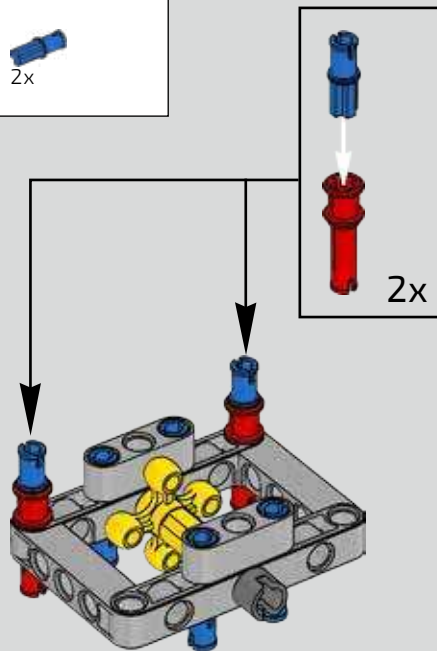

128

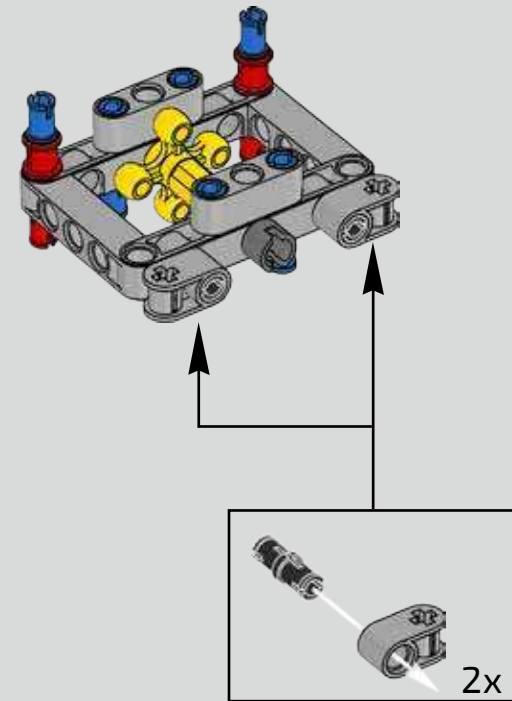

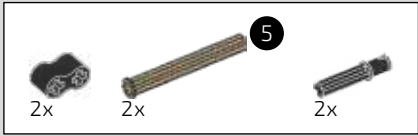

129

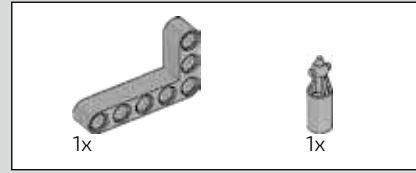
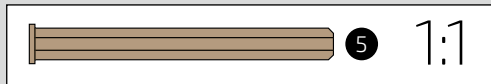
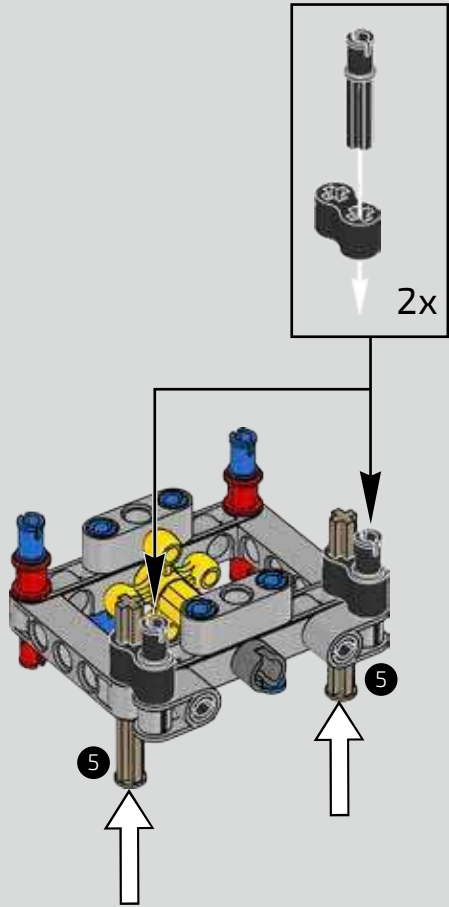

130

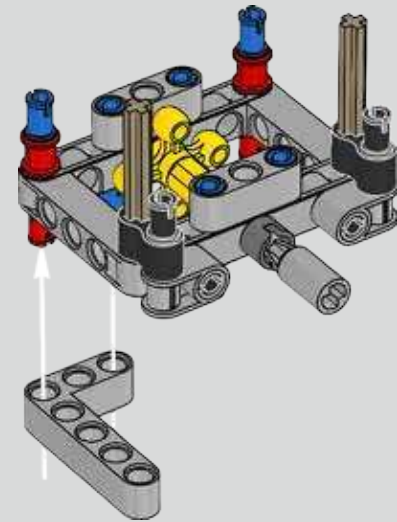

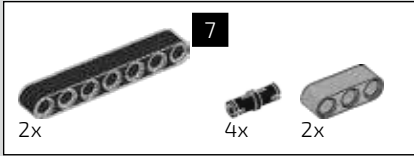

131

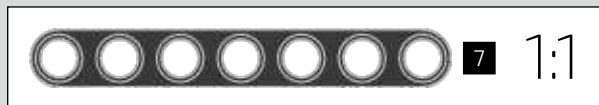
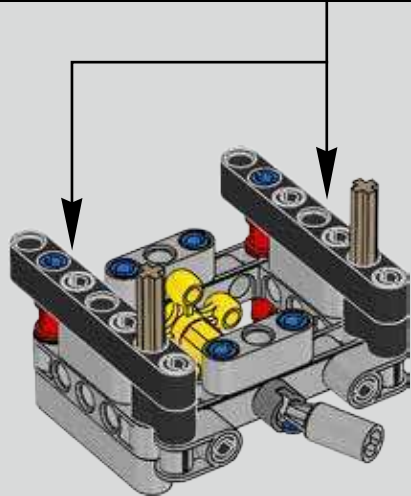
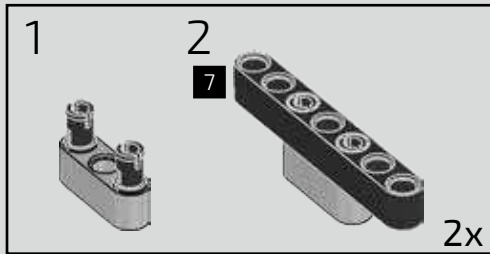

132

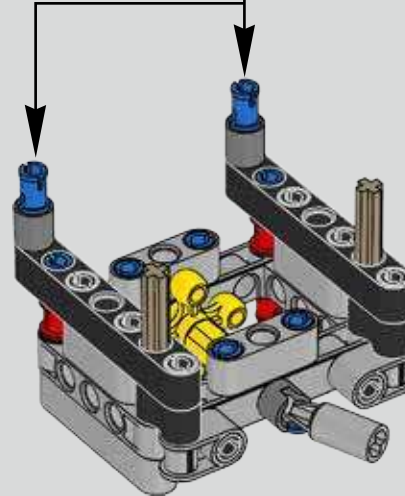
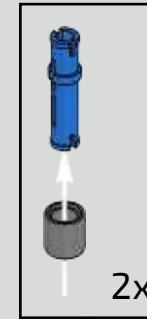

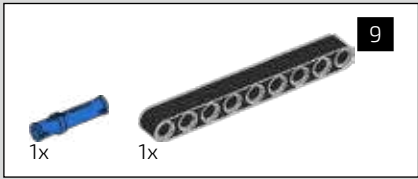
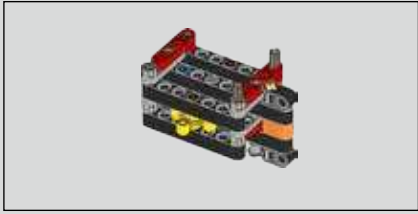

133

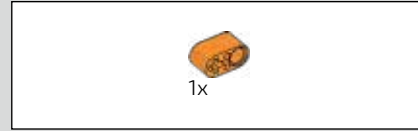
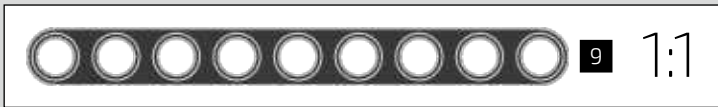
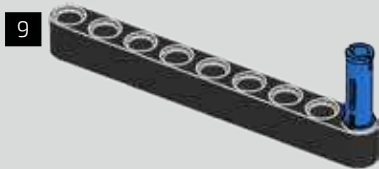

134

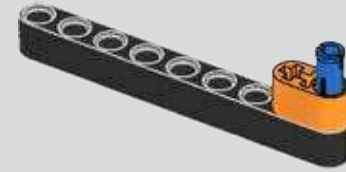

135

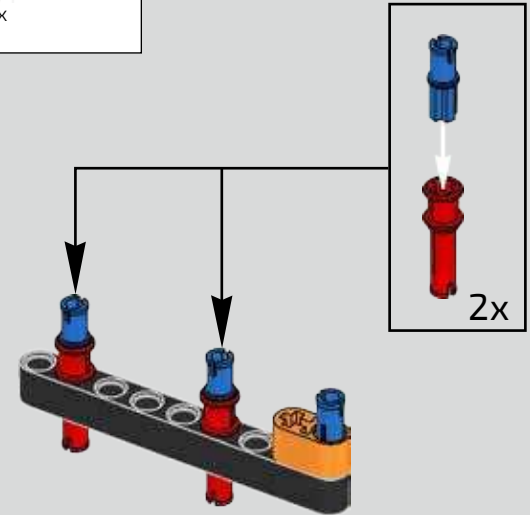

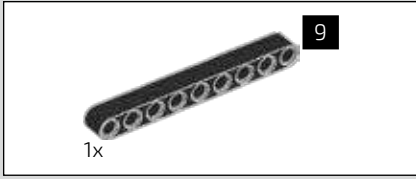

136

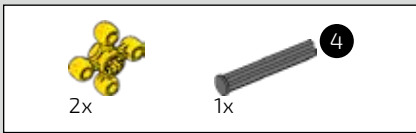
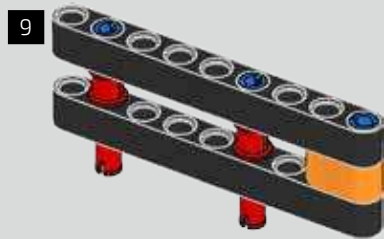

137

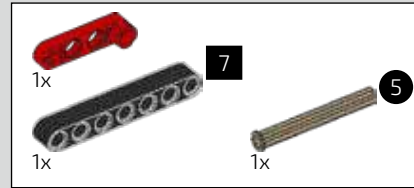
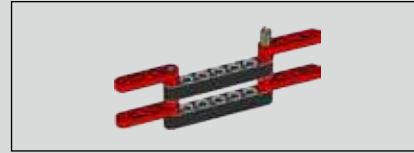
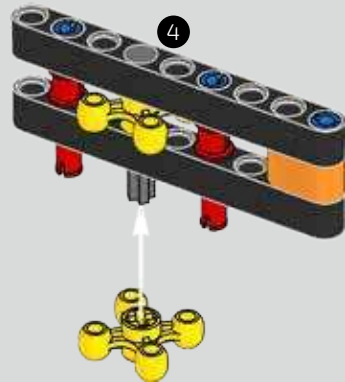

138

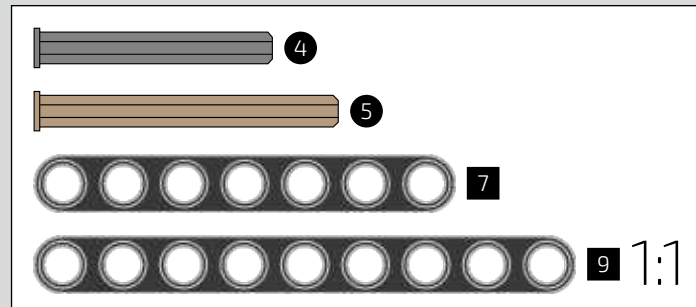
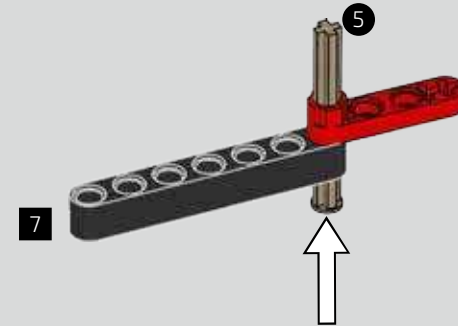

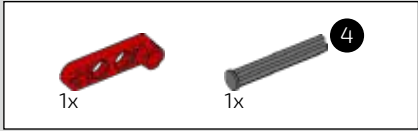

139

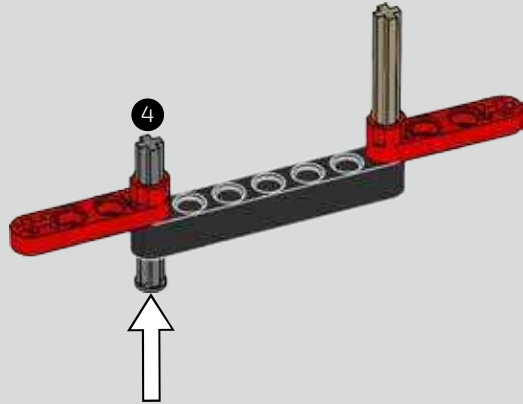

140

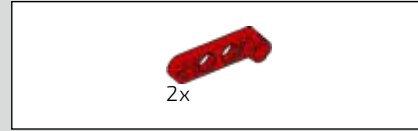
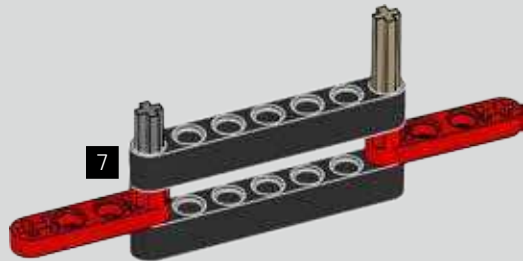

141

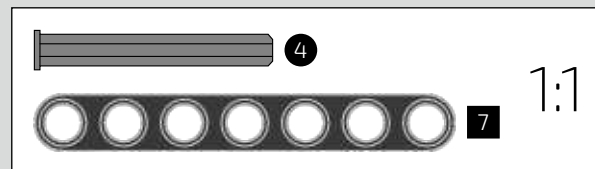
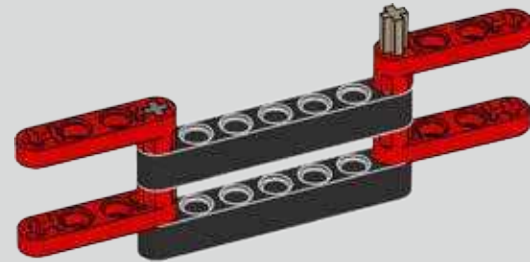

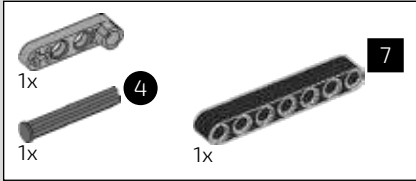
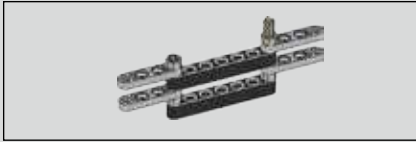

142

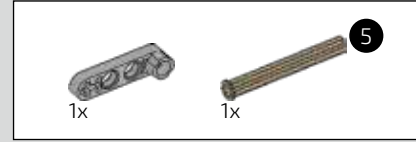
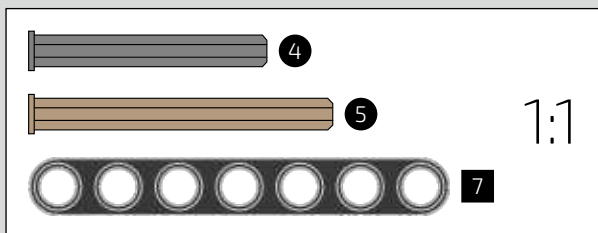
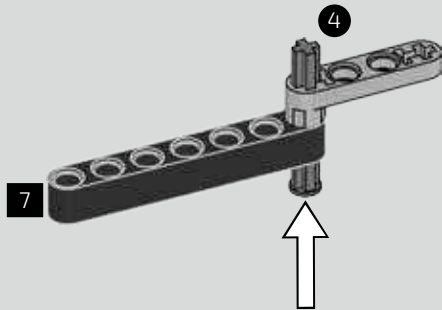

143

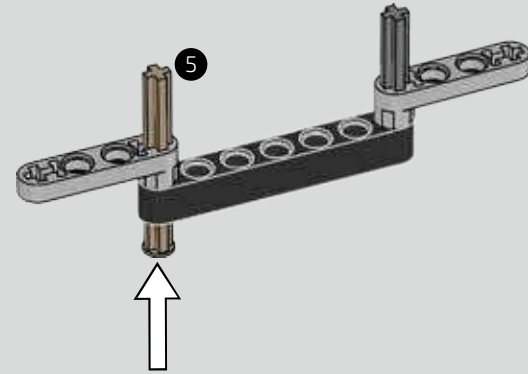

144

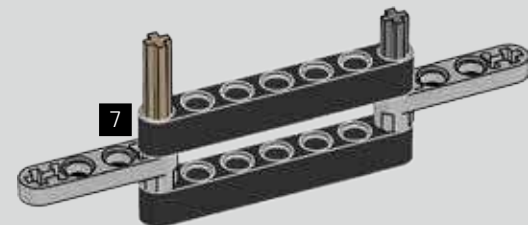

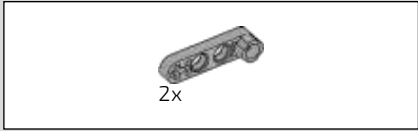

145

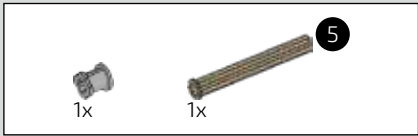
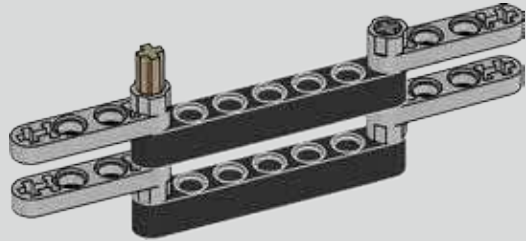

146

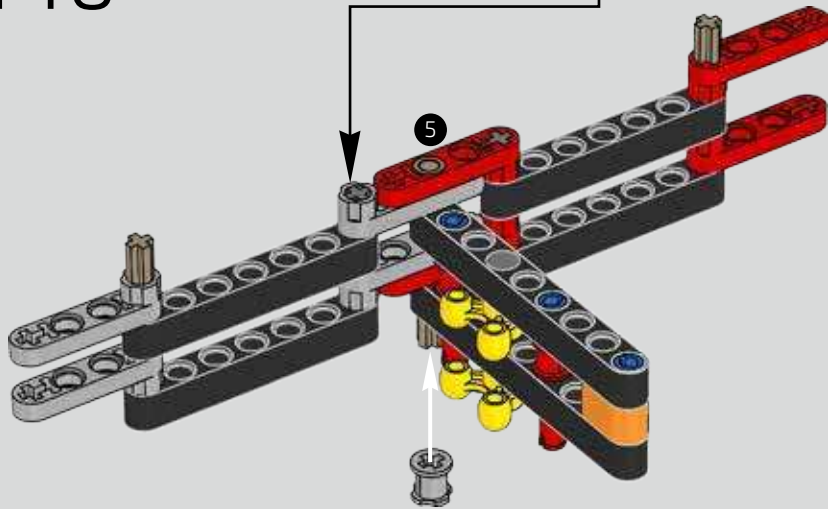

147

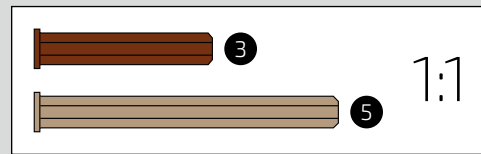
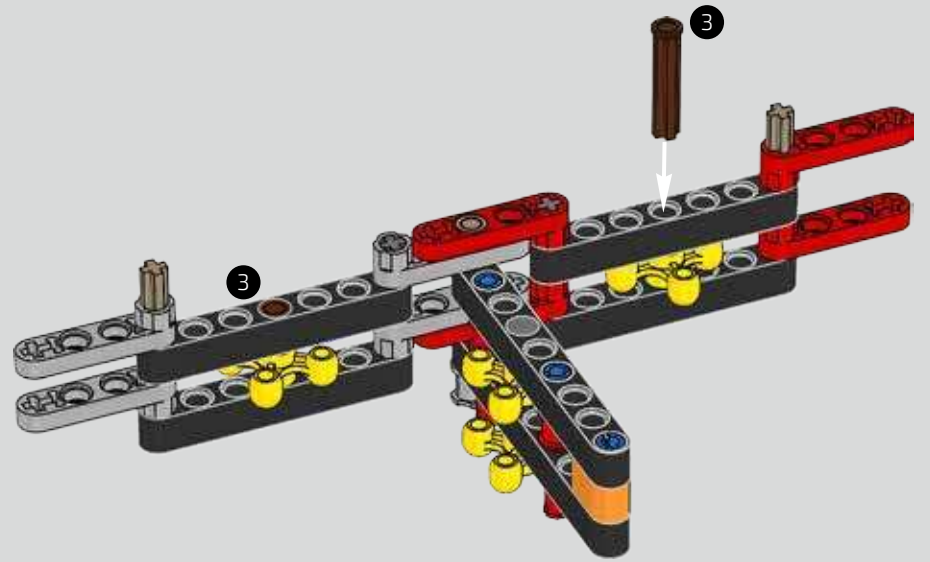

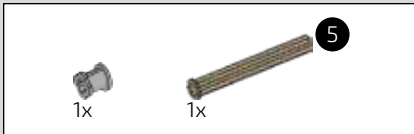

148

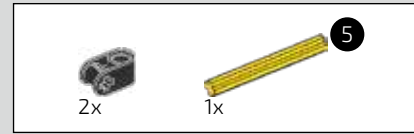
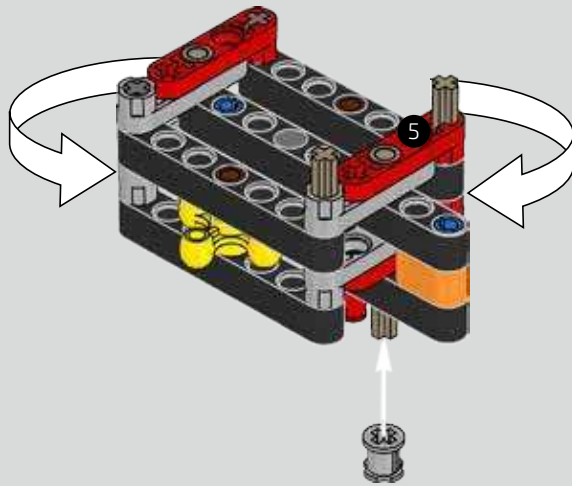

149

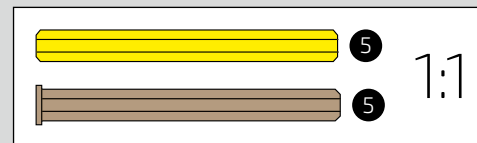
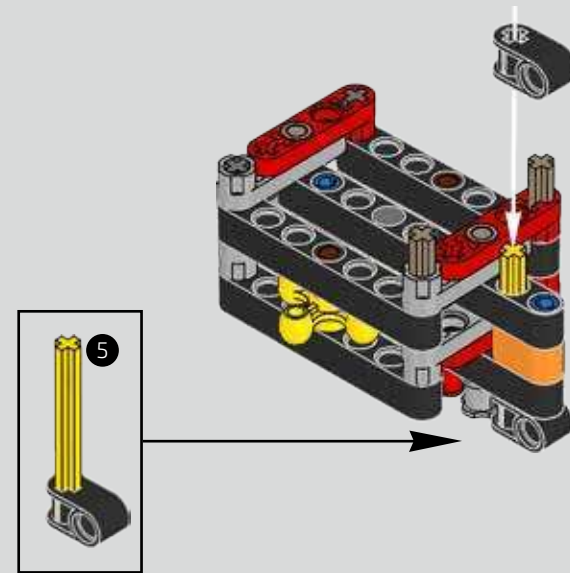

150

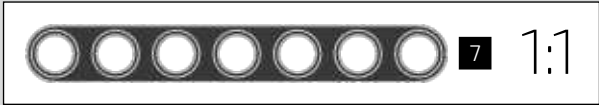
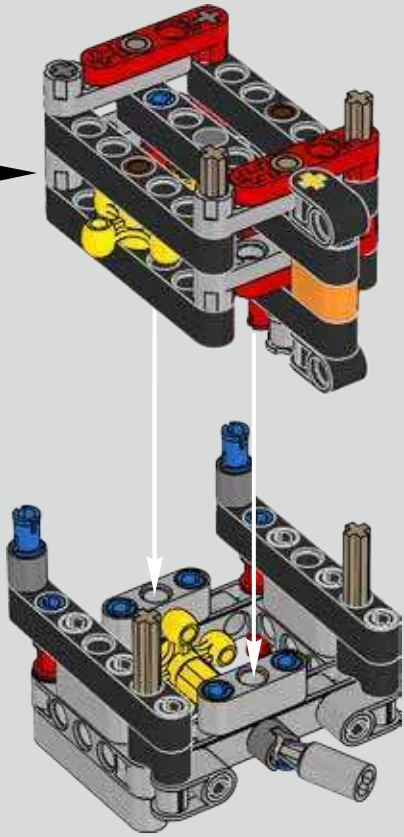

151

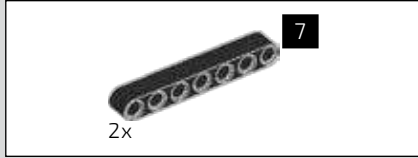
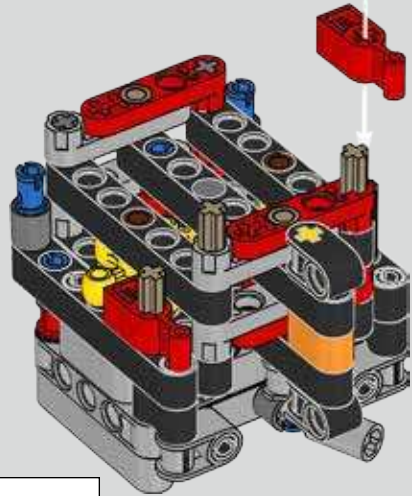

152

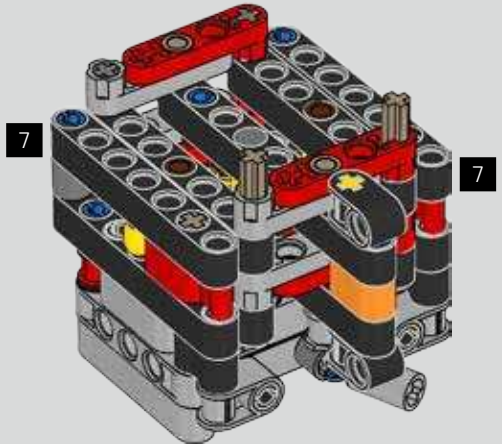

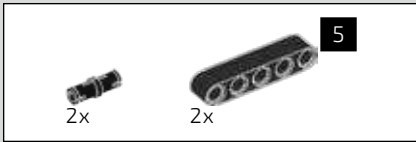

153

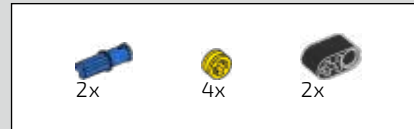
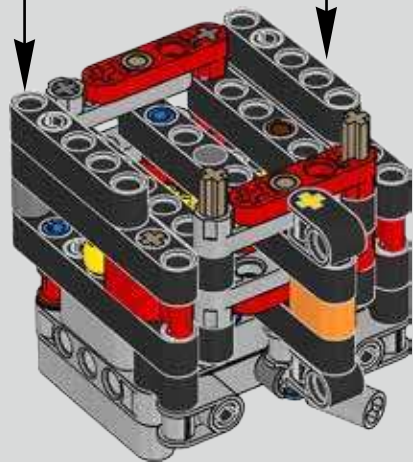

154

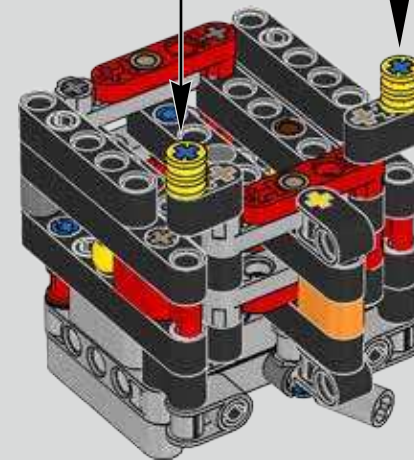
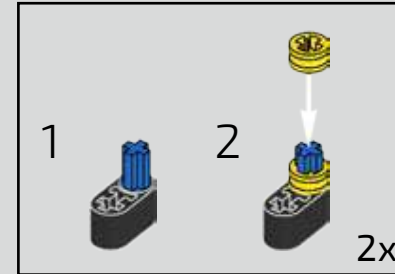

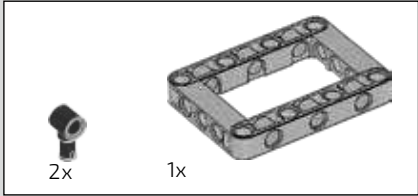
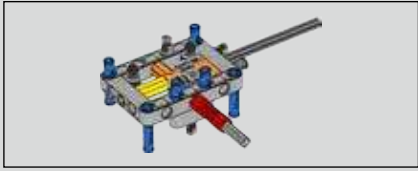

155

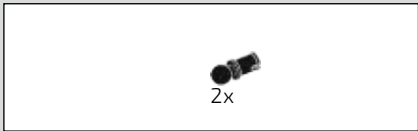
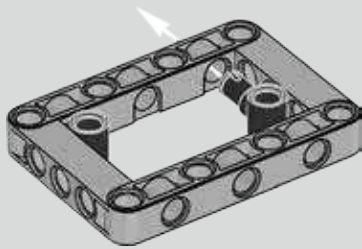

156

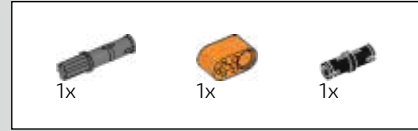
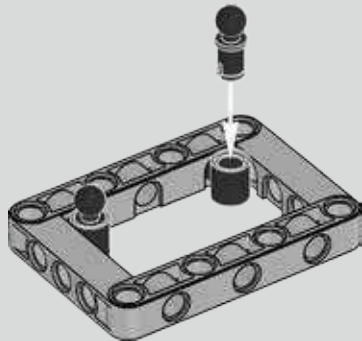

157

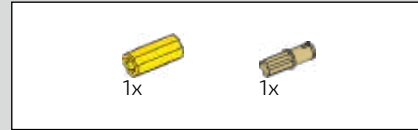
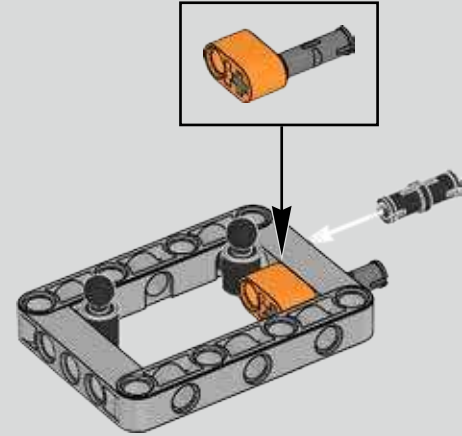

158

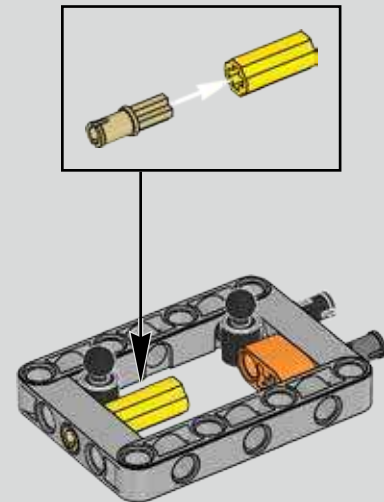

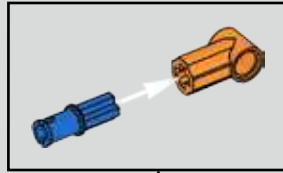

159

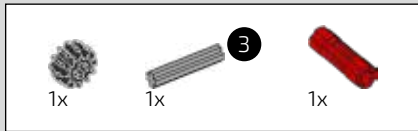
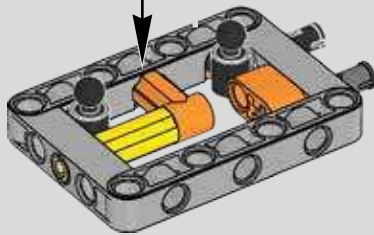

160

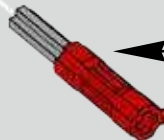
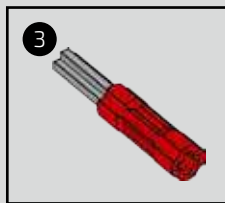
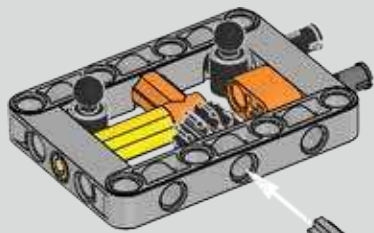

161

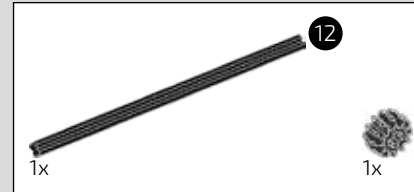
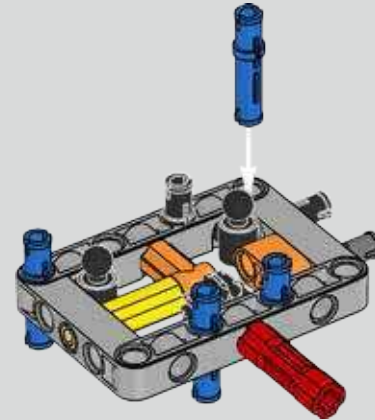

162

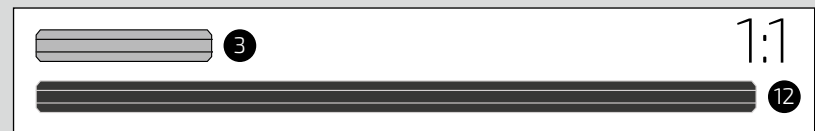
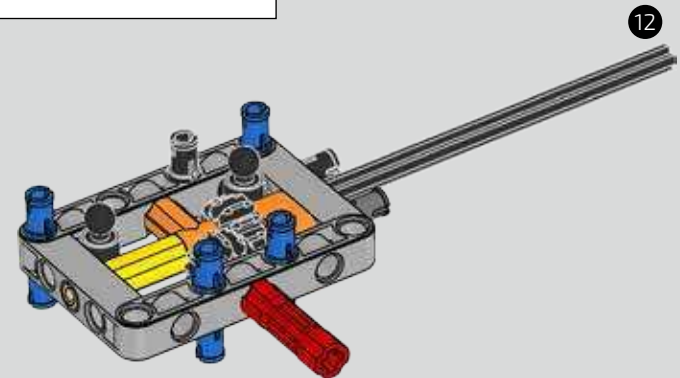

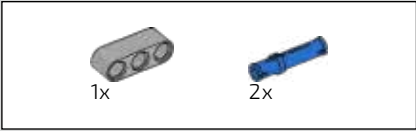

163

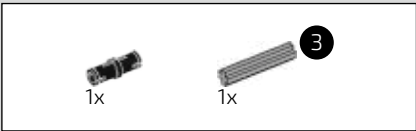
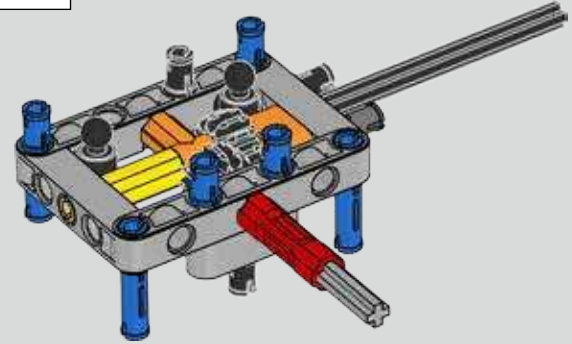
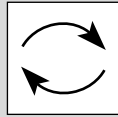
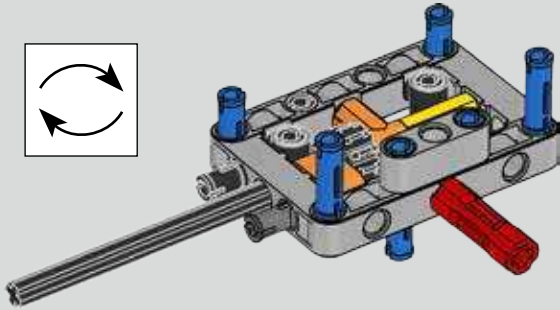
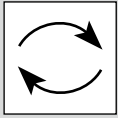

164

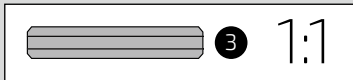
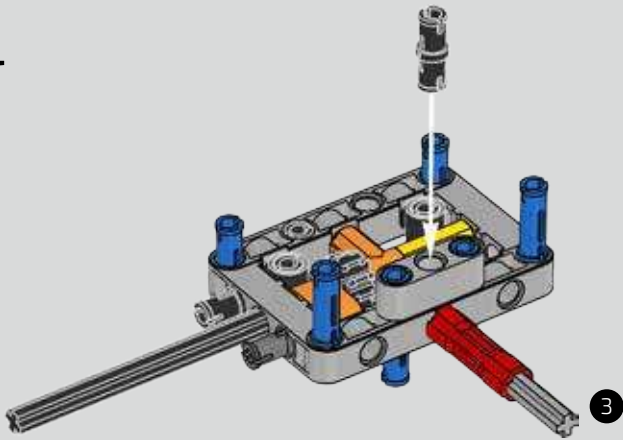

165

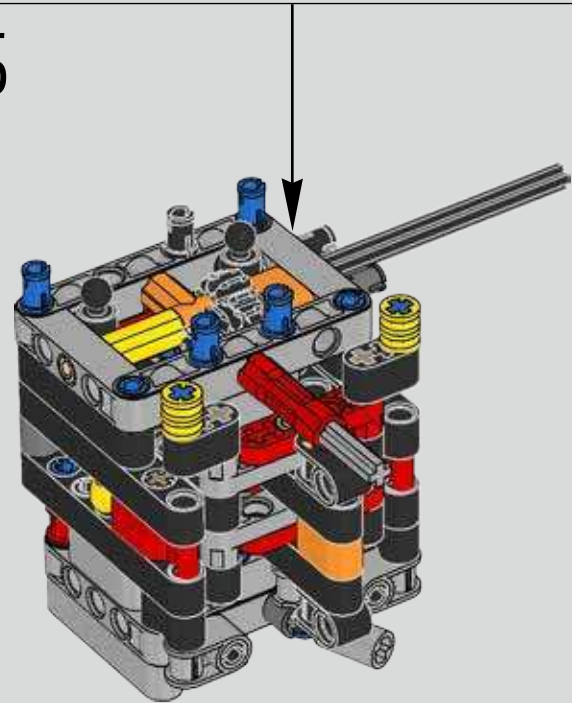



166

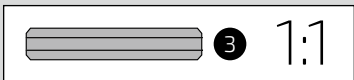
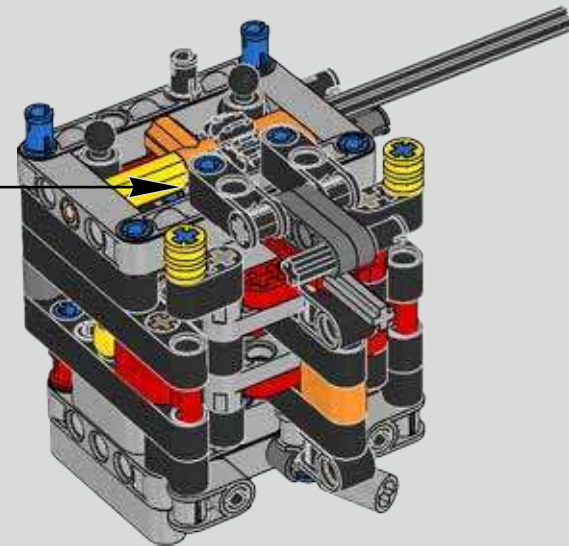
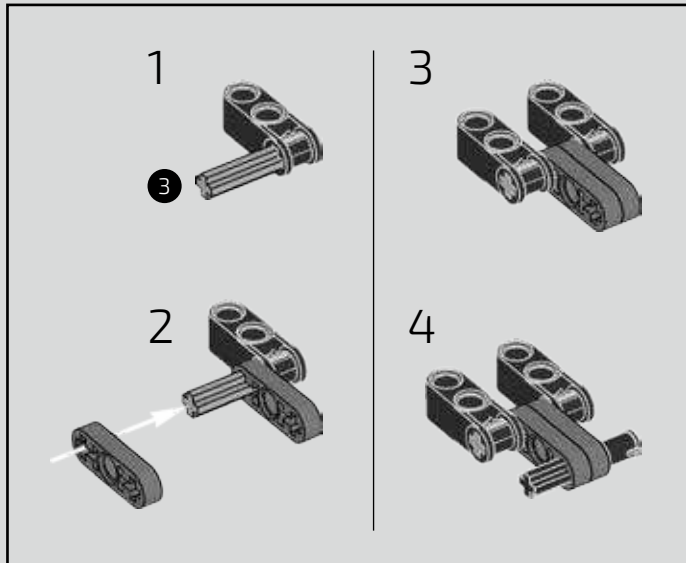

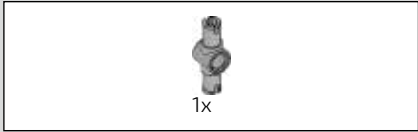

167

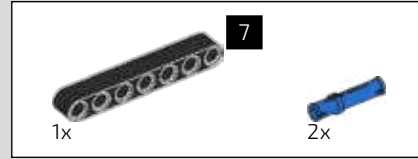
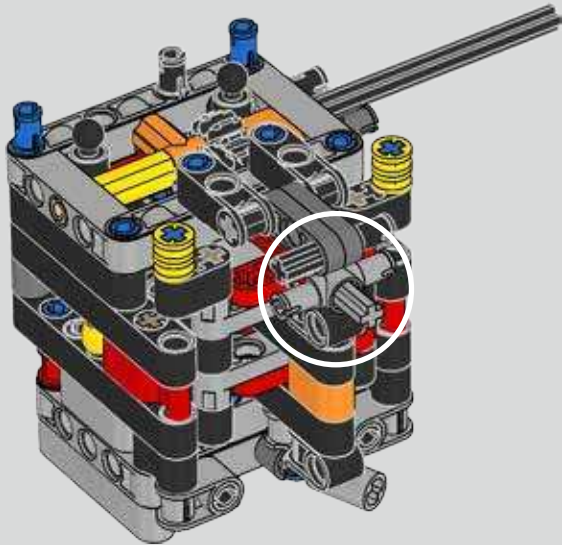

168

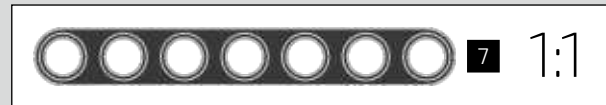
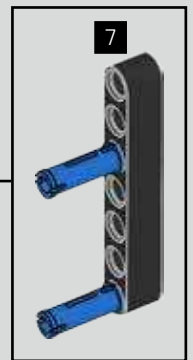
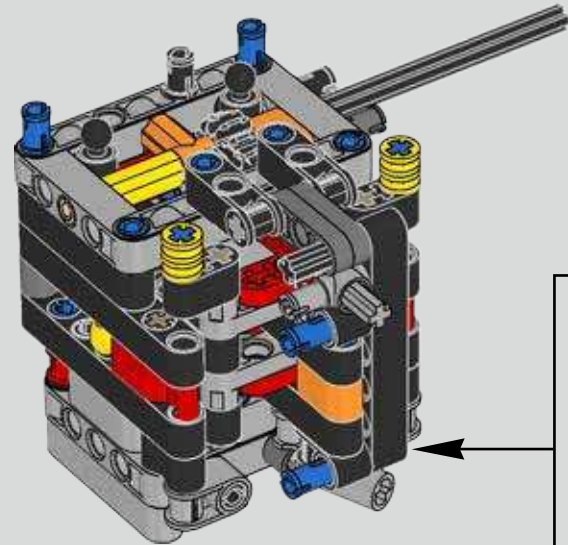



169

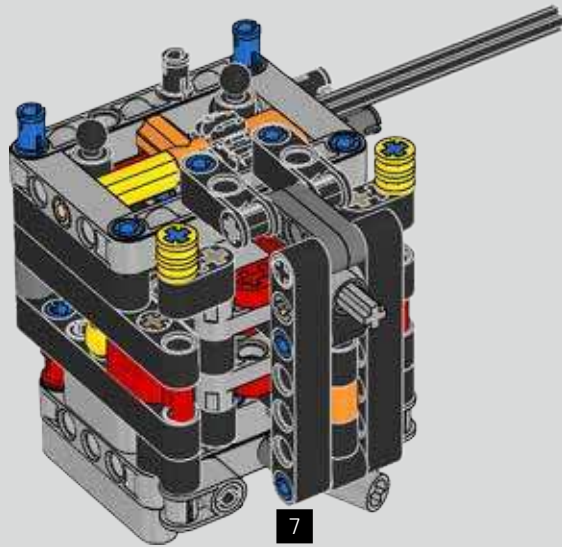

170

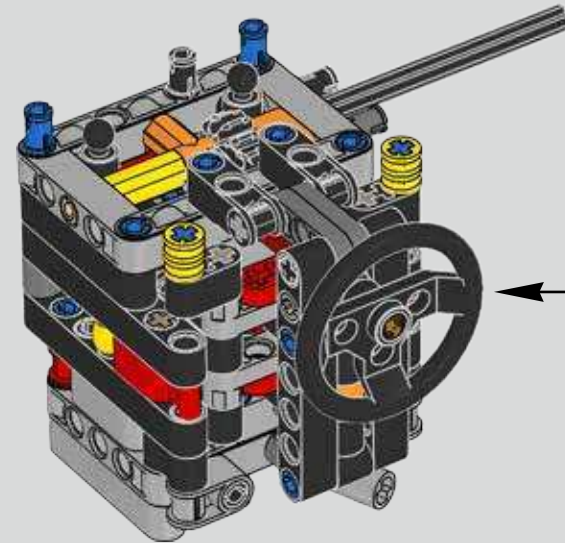
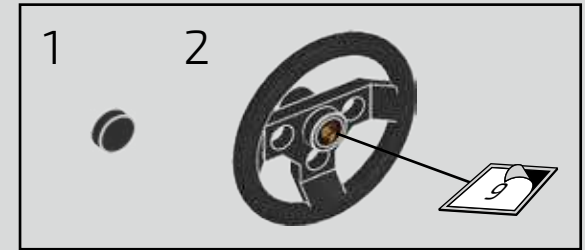

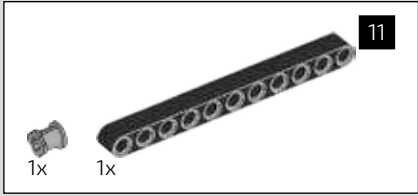

171

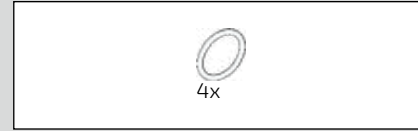
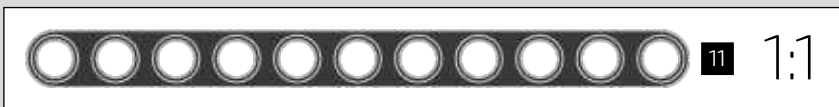
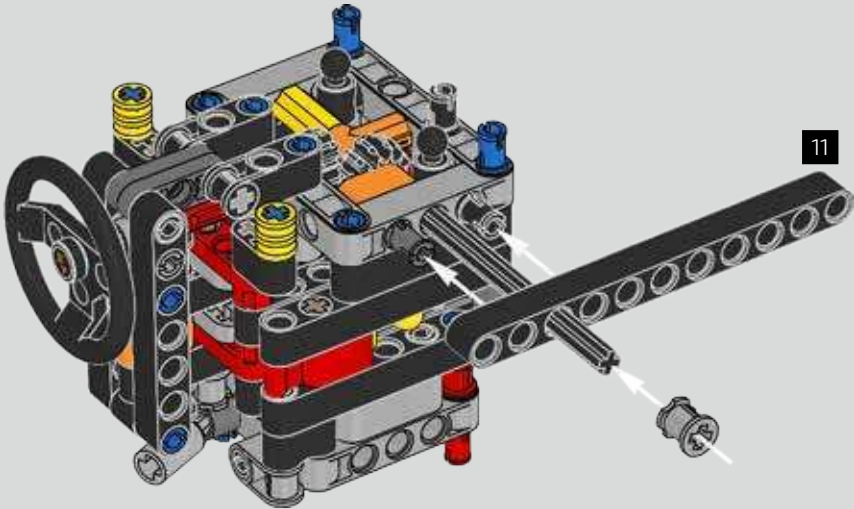
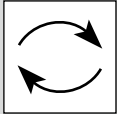

172

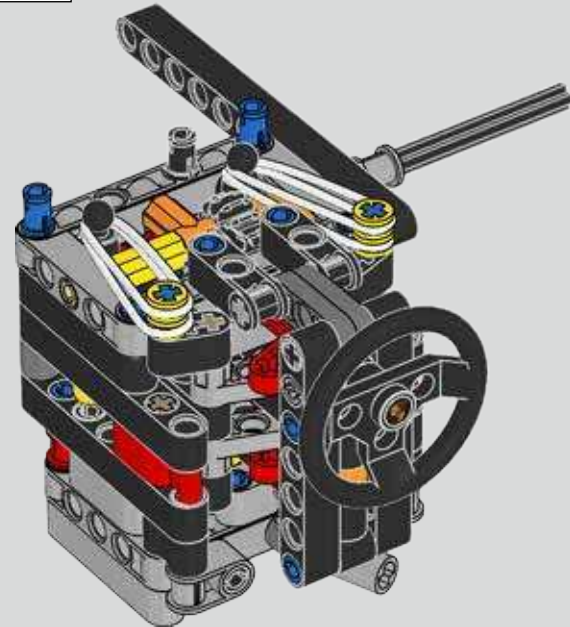
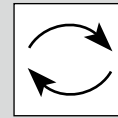

173

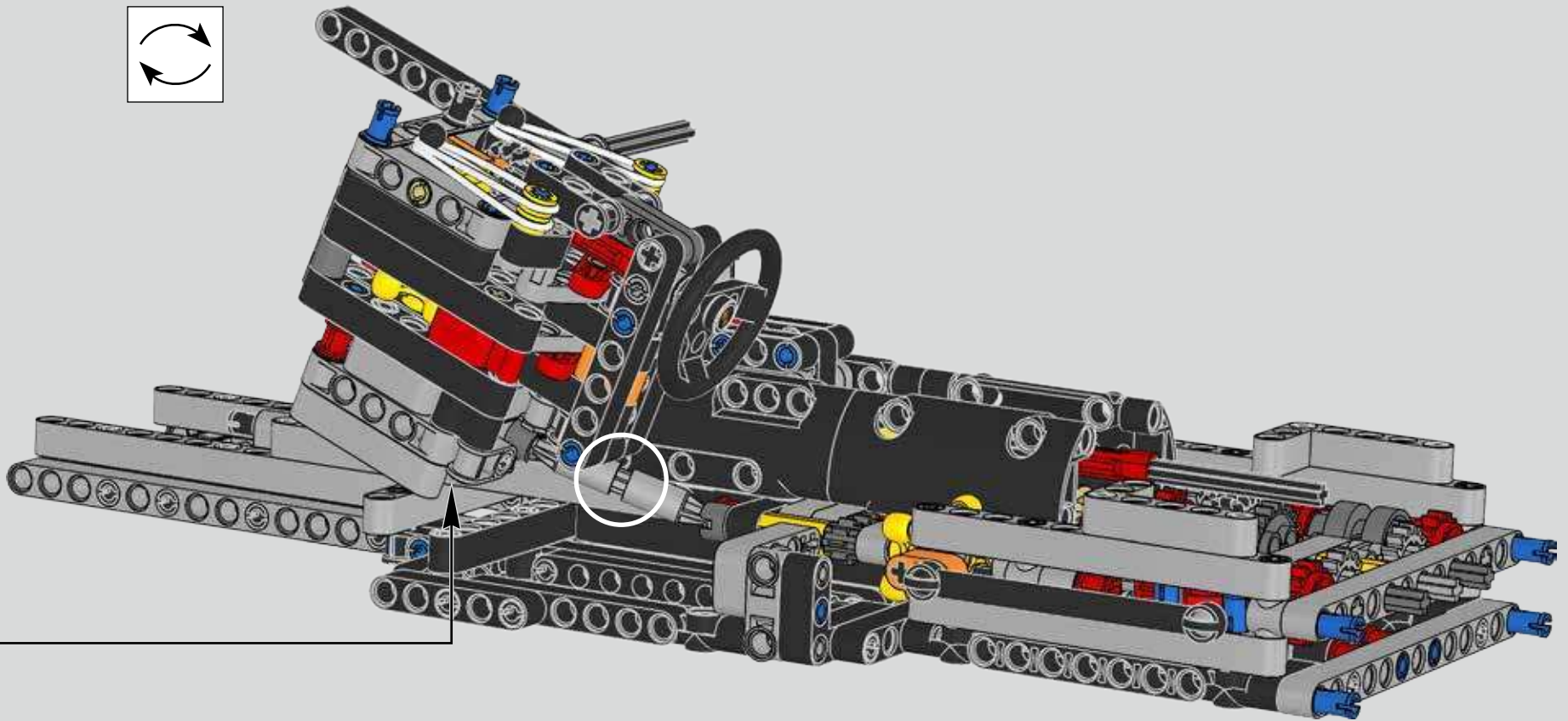
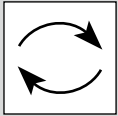

174

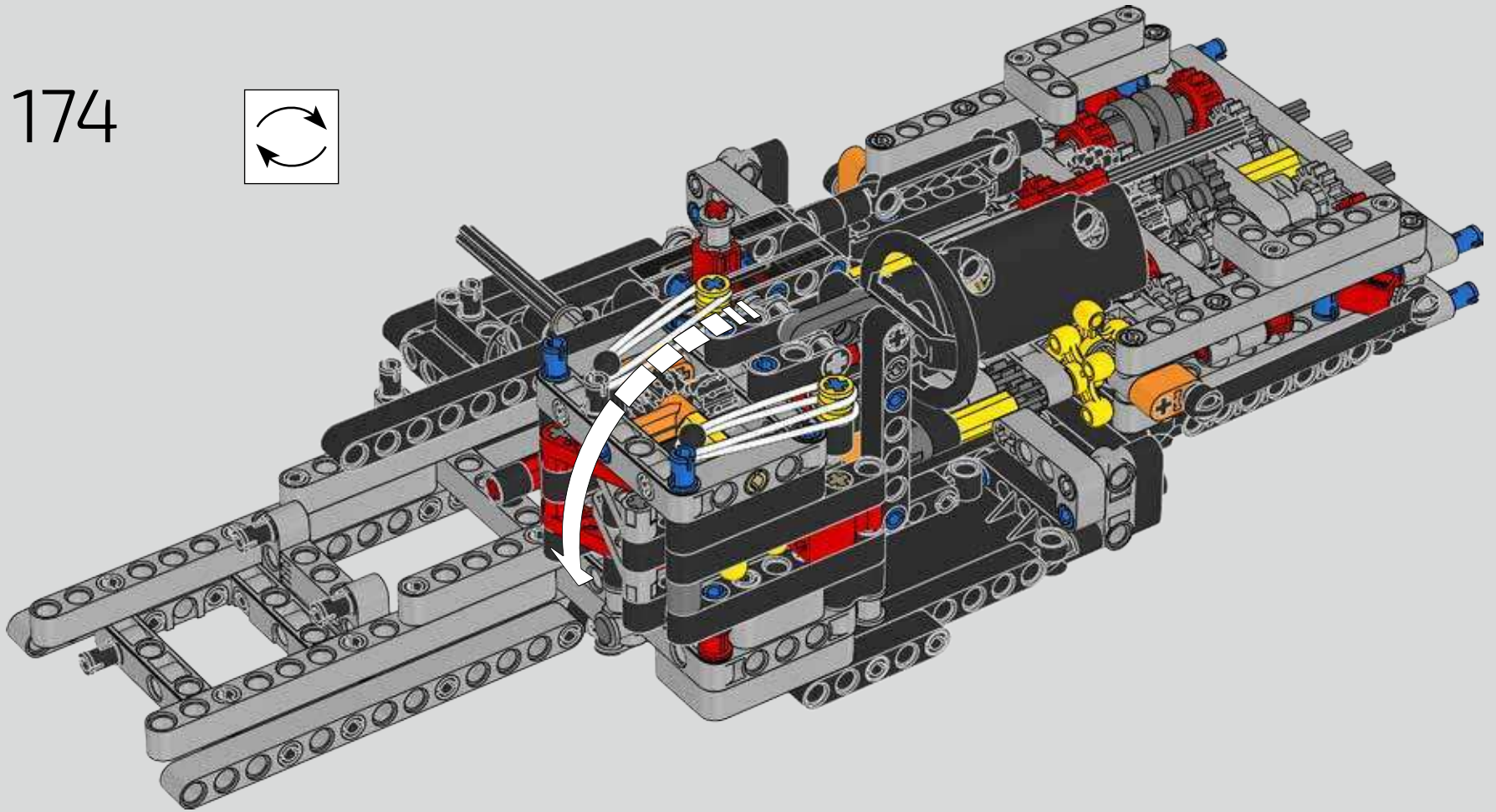
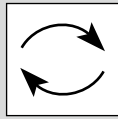

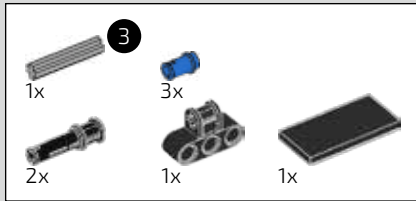

175

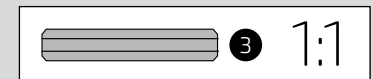
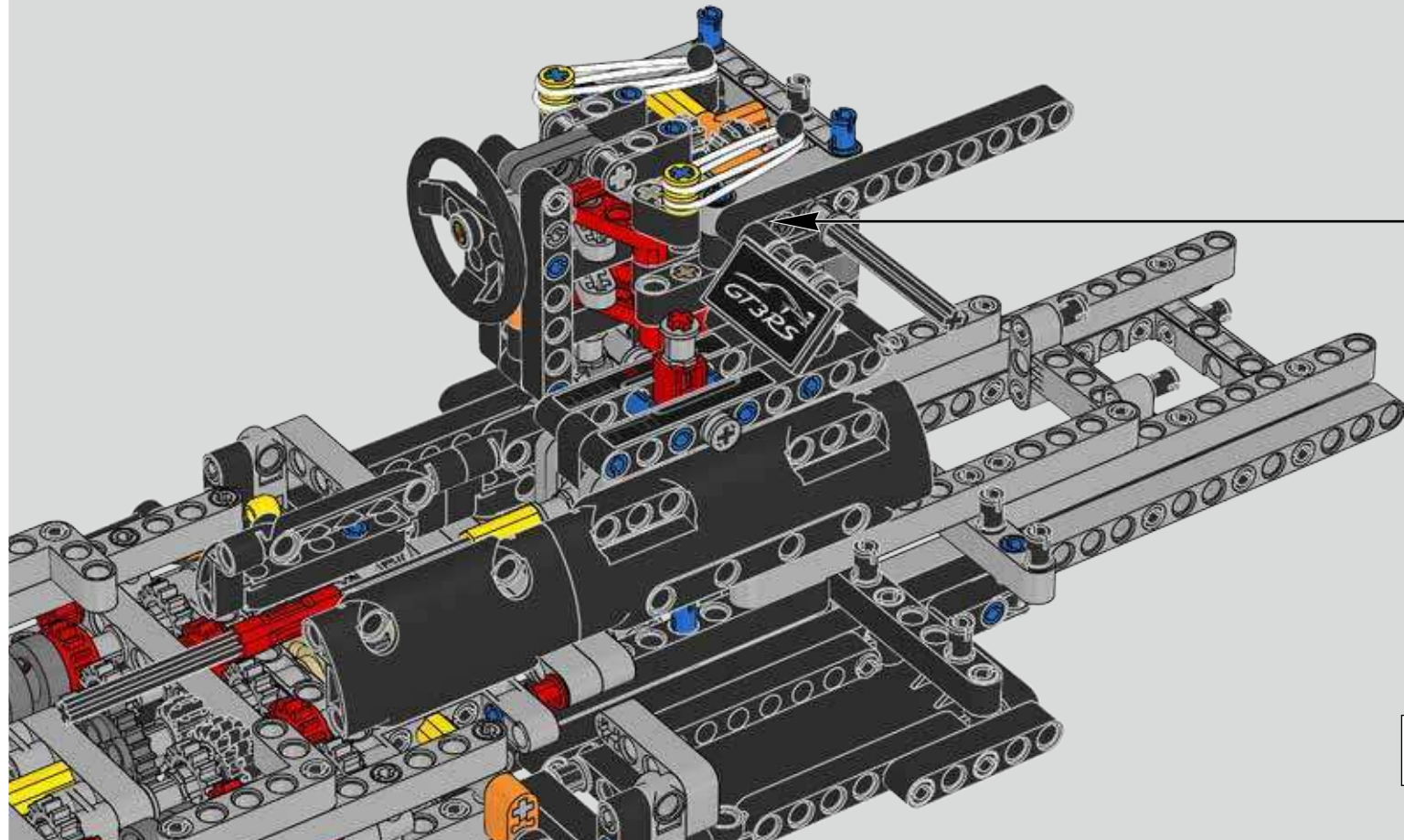
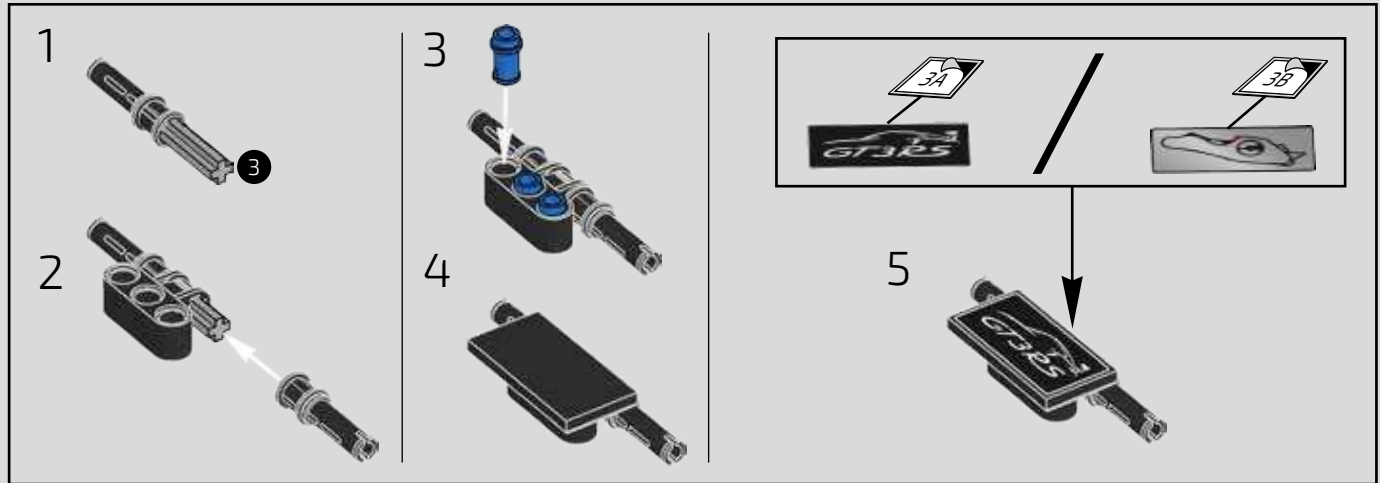
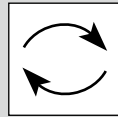

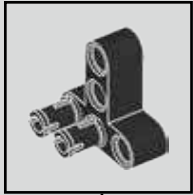
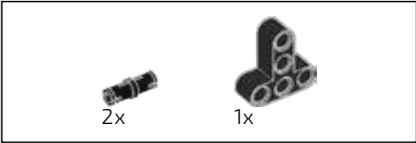

176

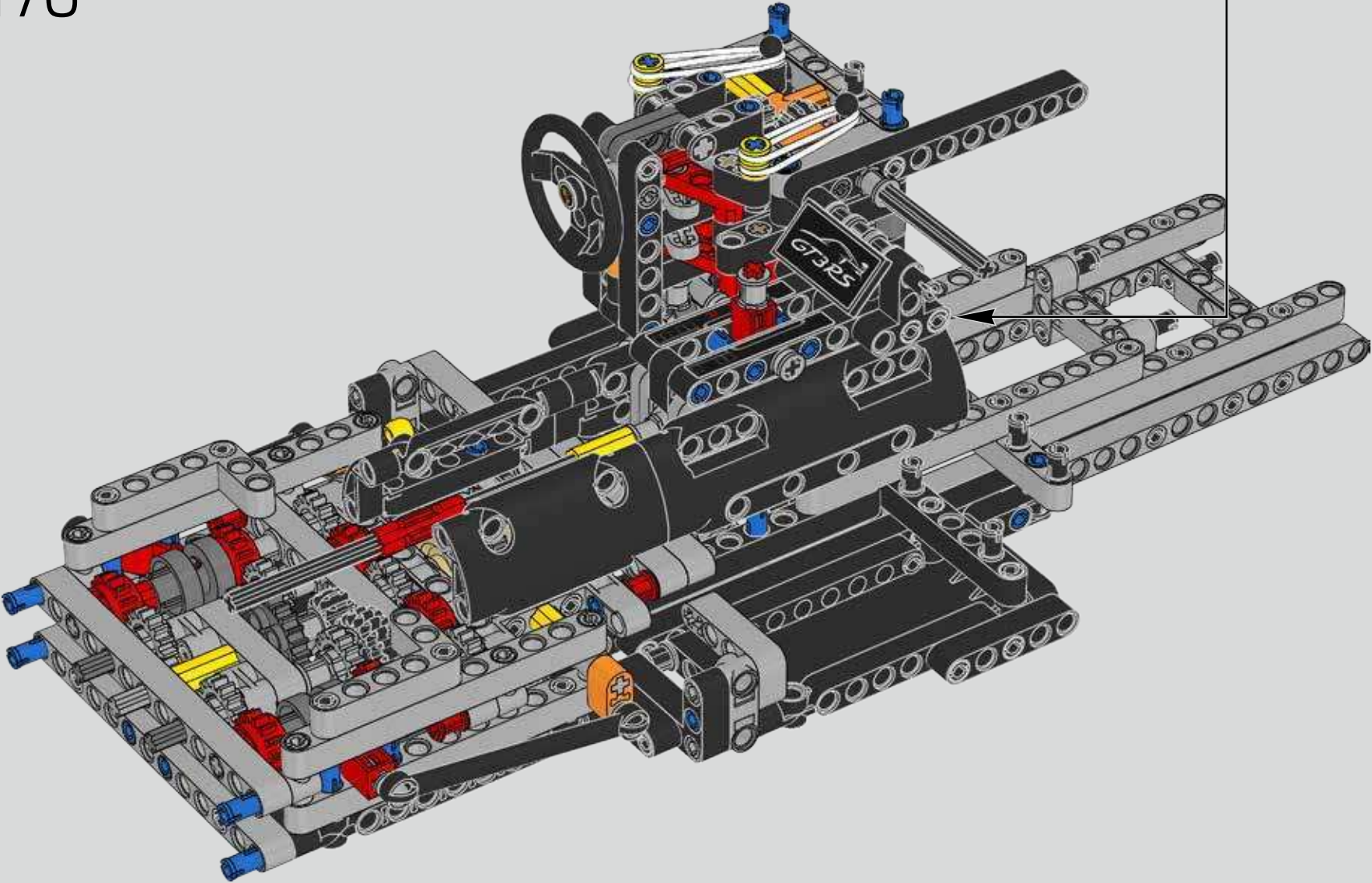

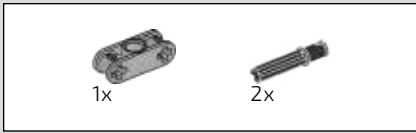
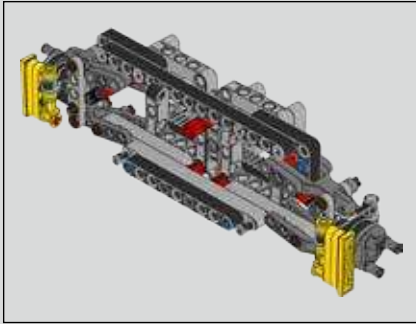

177

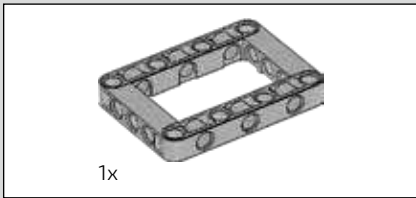

178

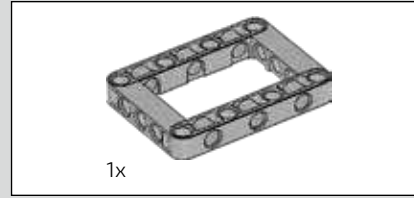
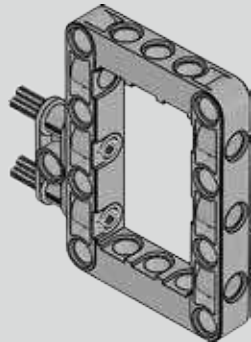
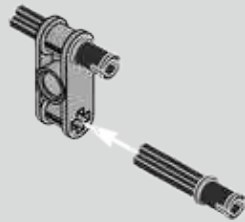

179

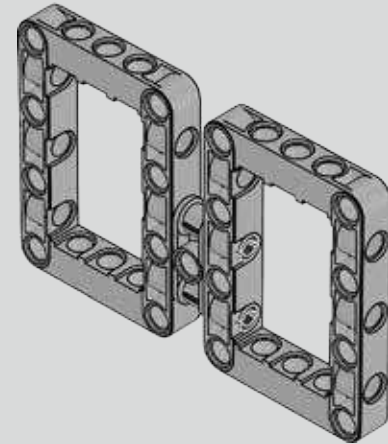

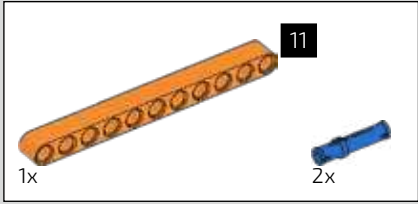

180

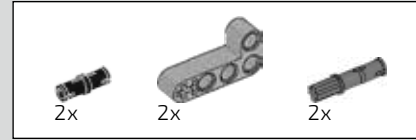
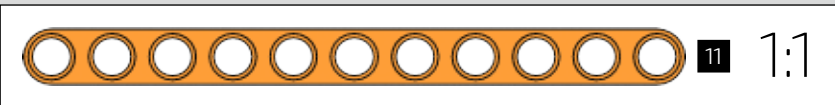
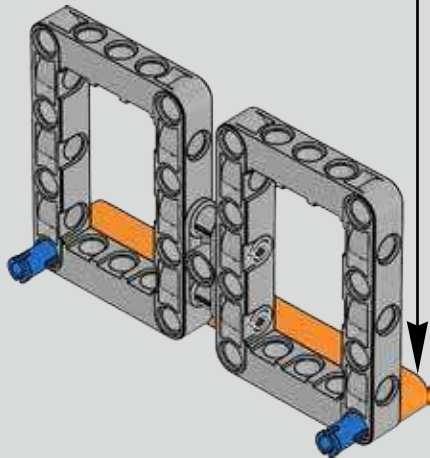
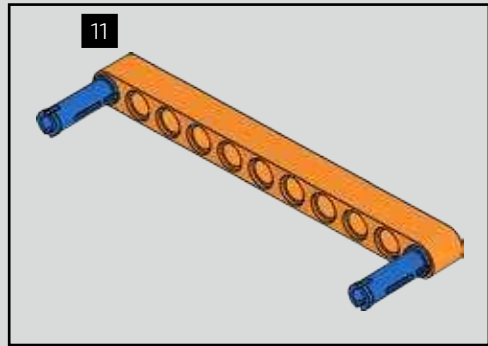

181

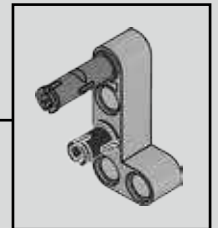
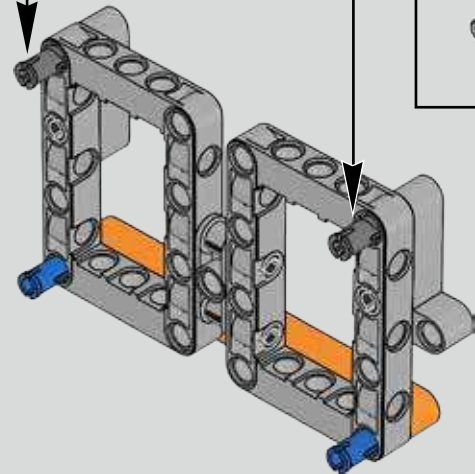
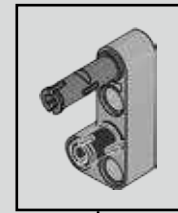

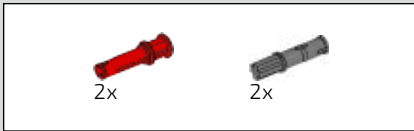

182

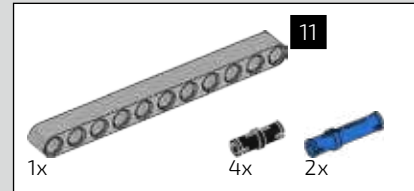
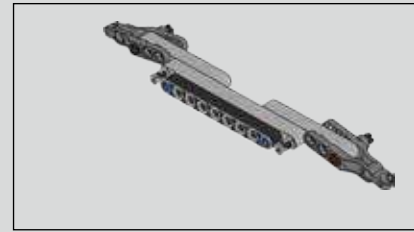
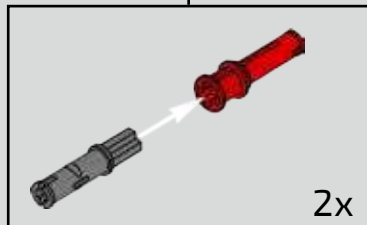
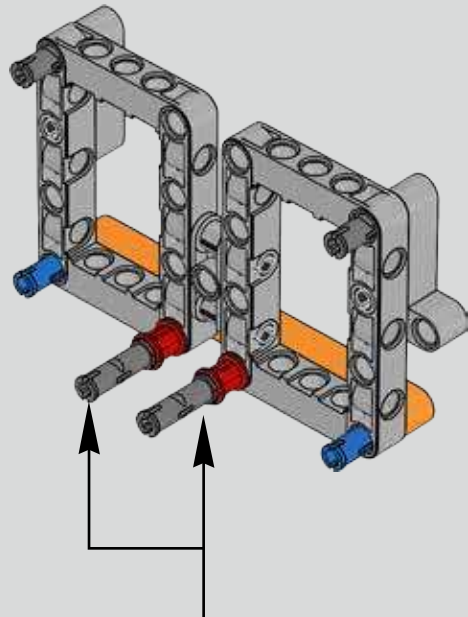

183

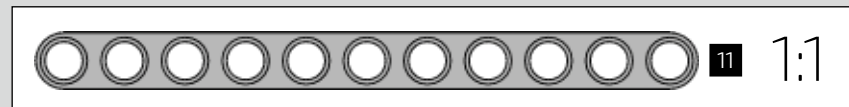
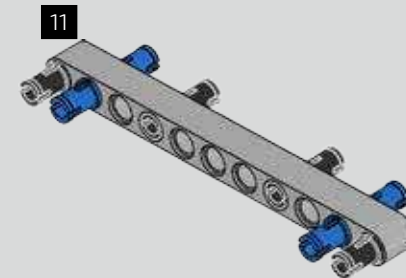

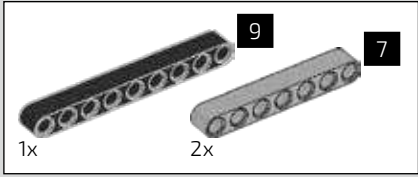

184

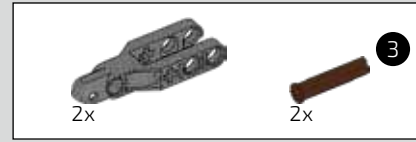
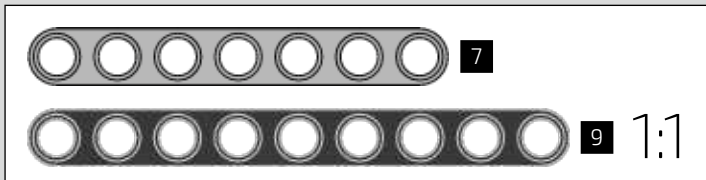
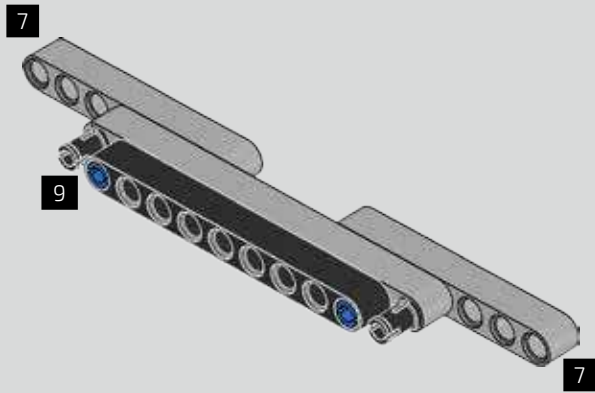

185

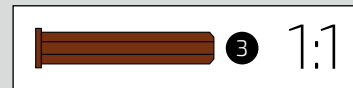
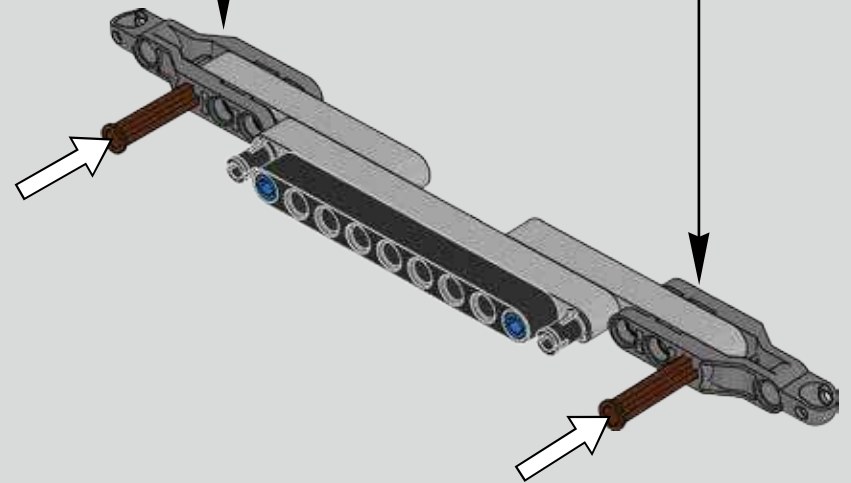
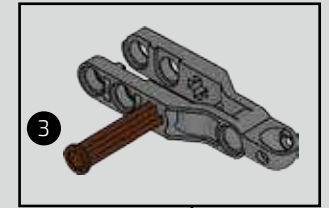
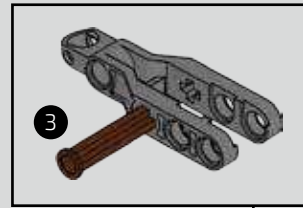
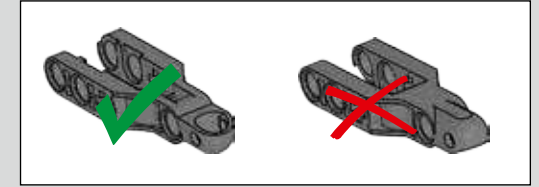



186

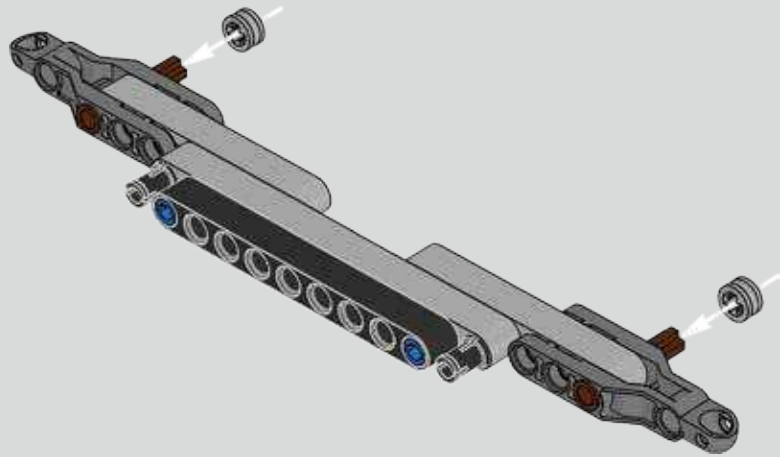

187

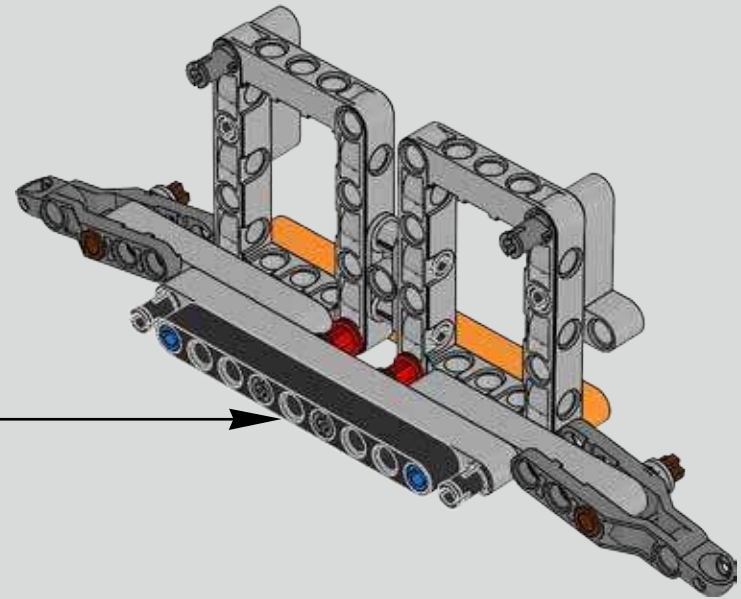

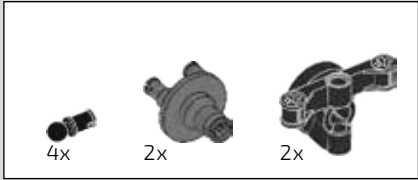

188

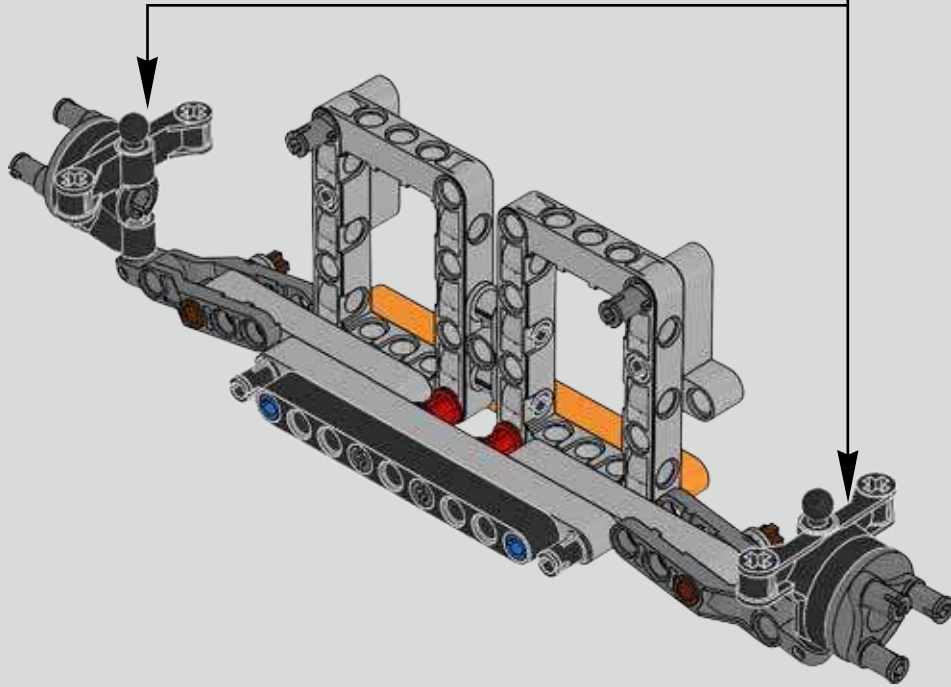
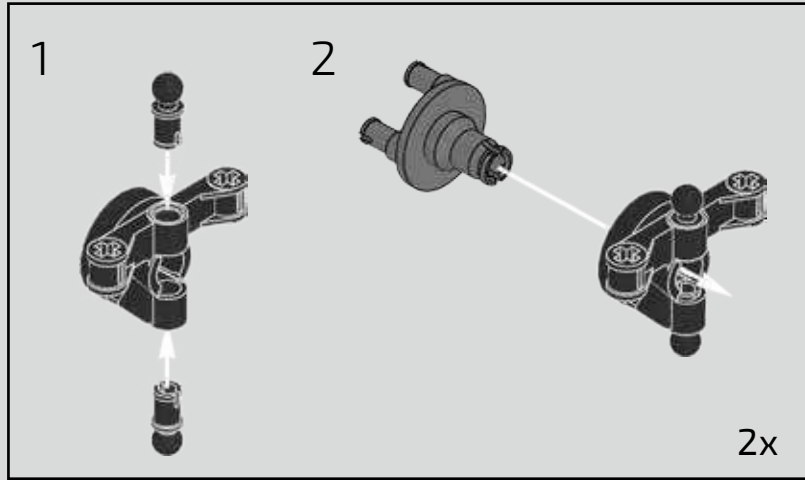
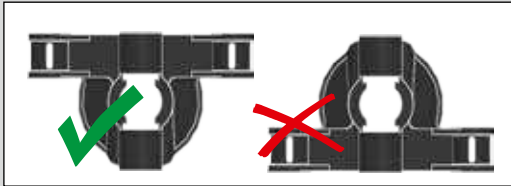

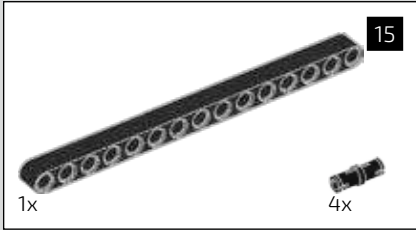
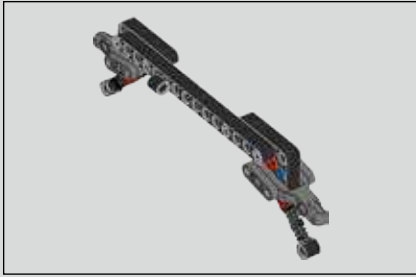

189

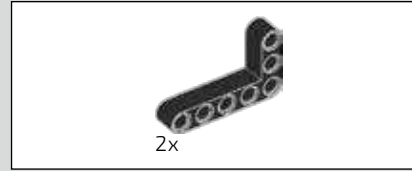
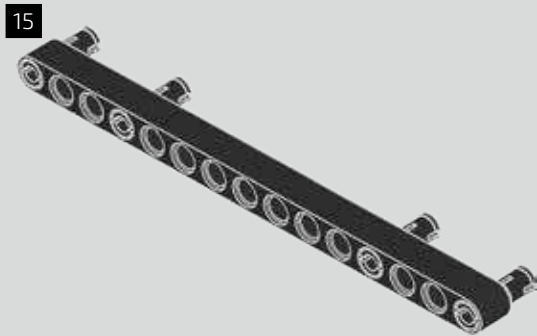

190

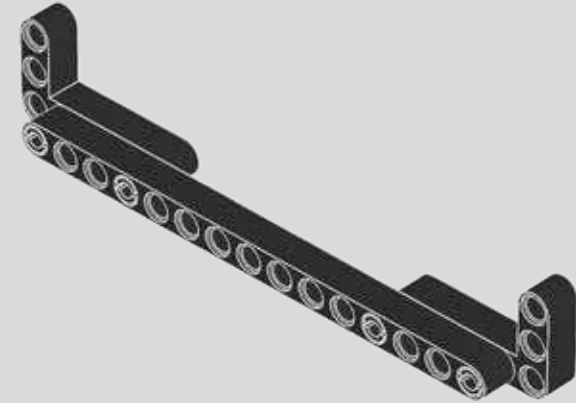

191

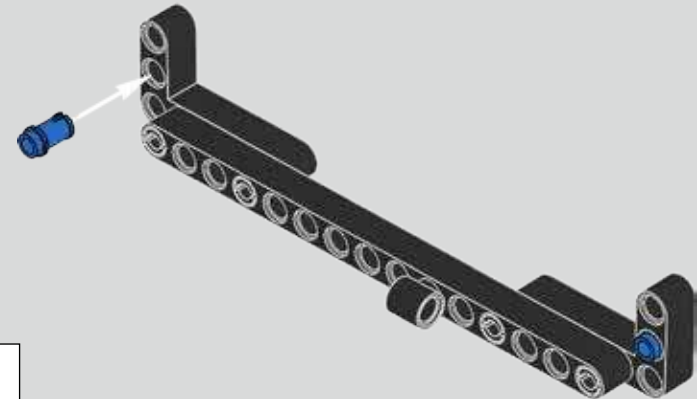

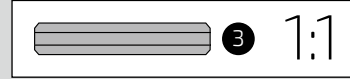
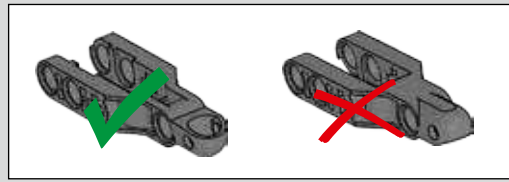
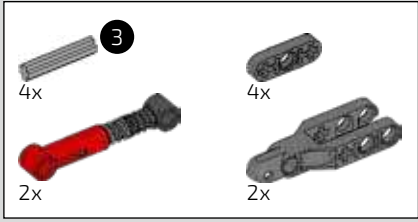

192

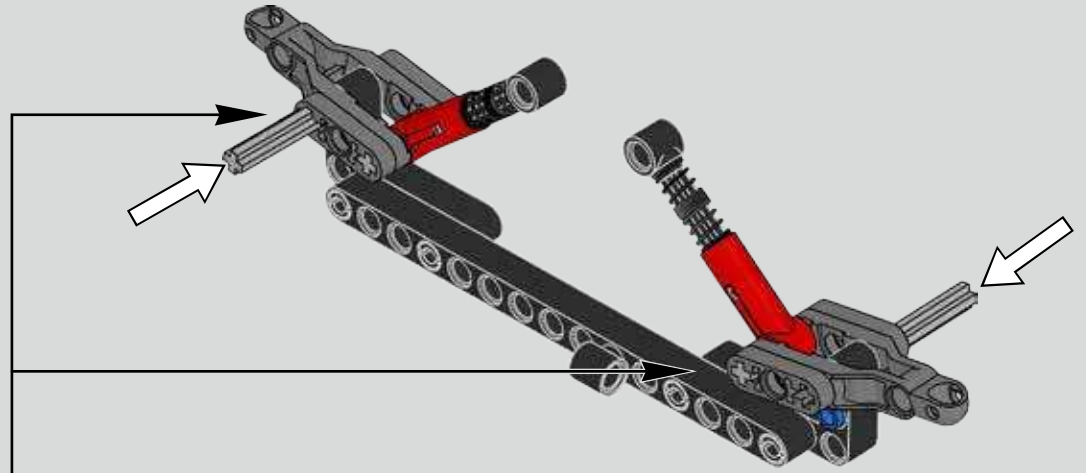
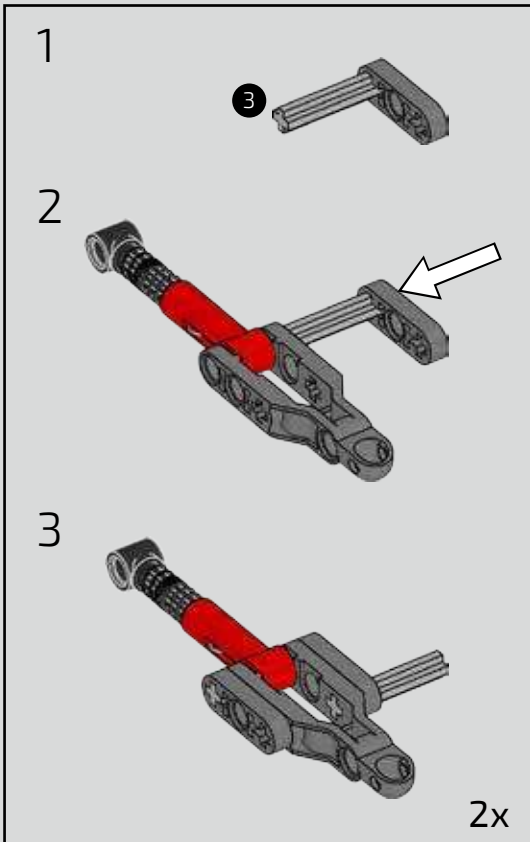

193

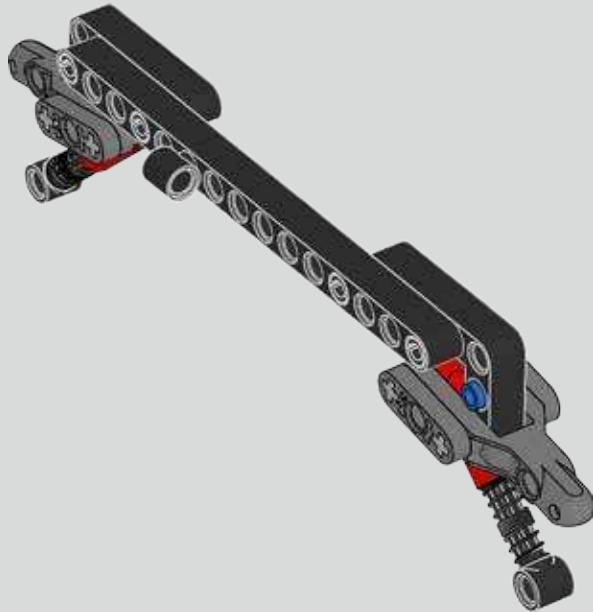
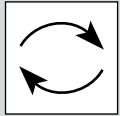

194

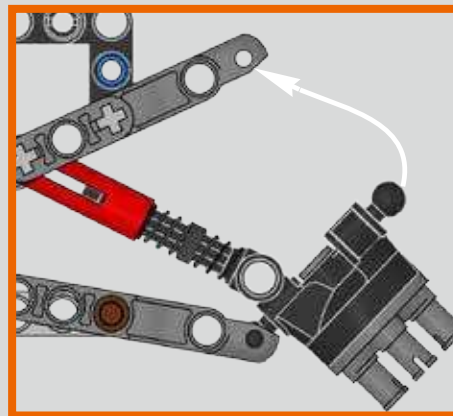
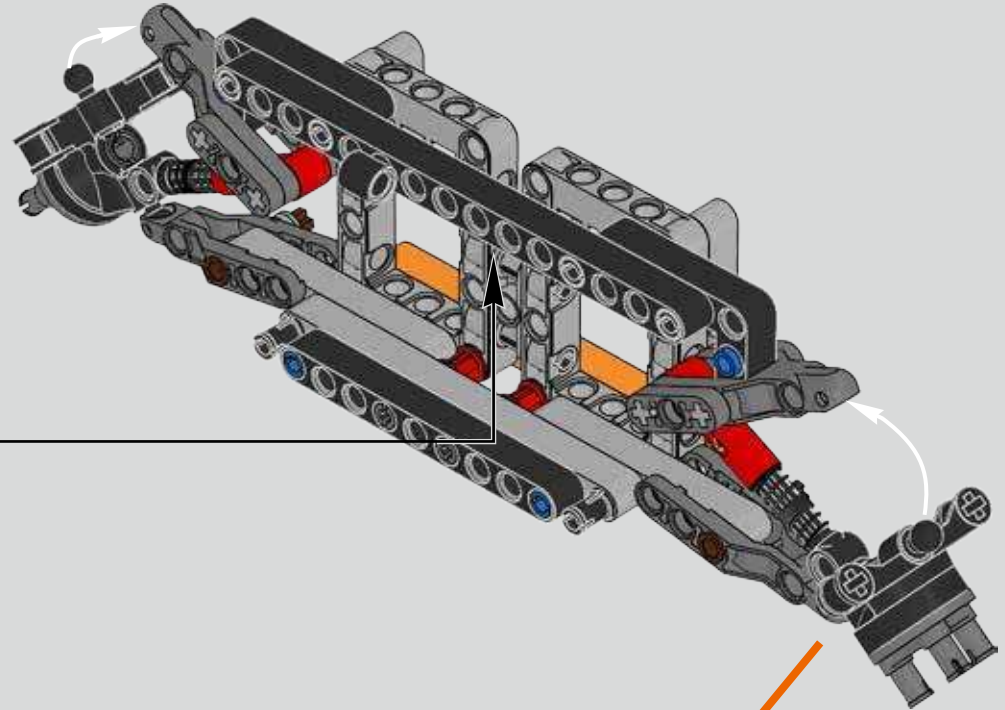



195

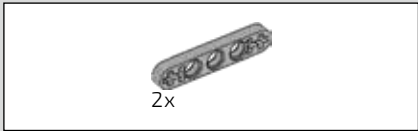
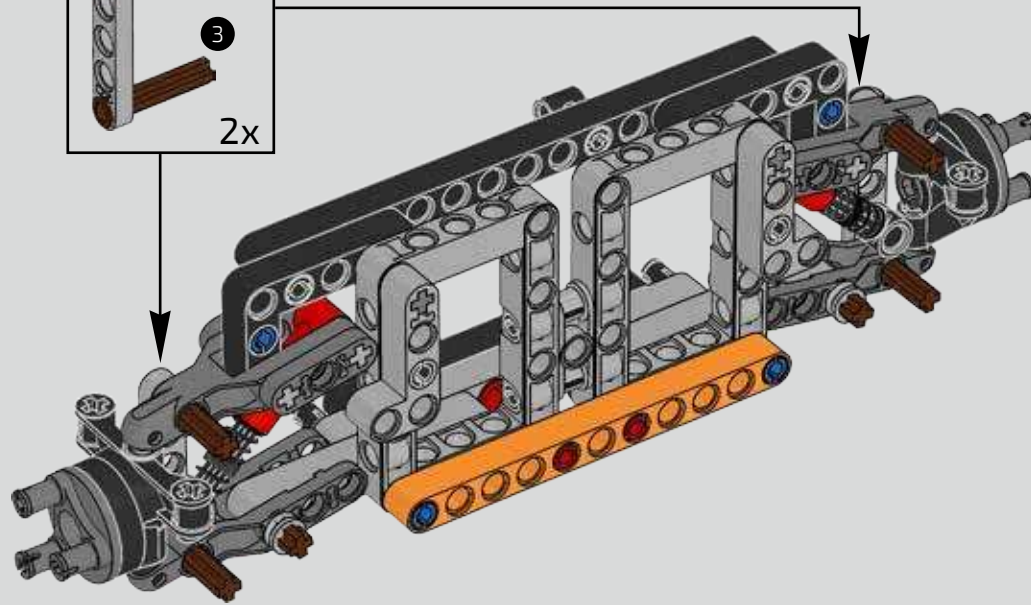
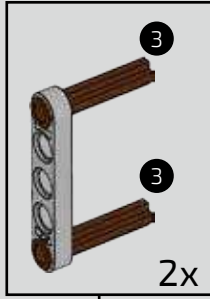
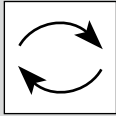

196

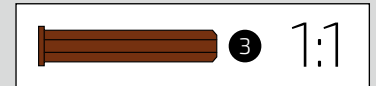
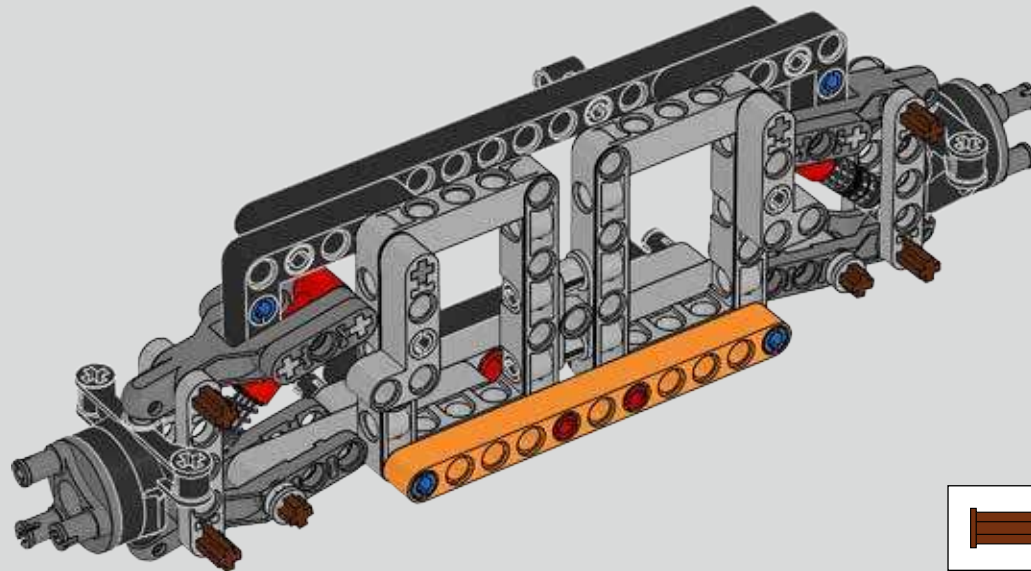



197

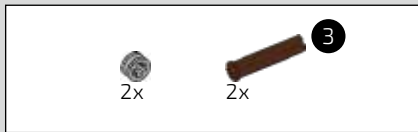
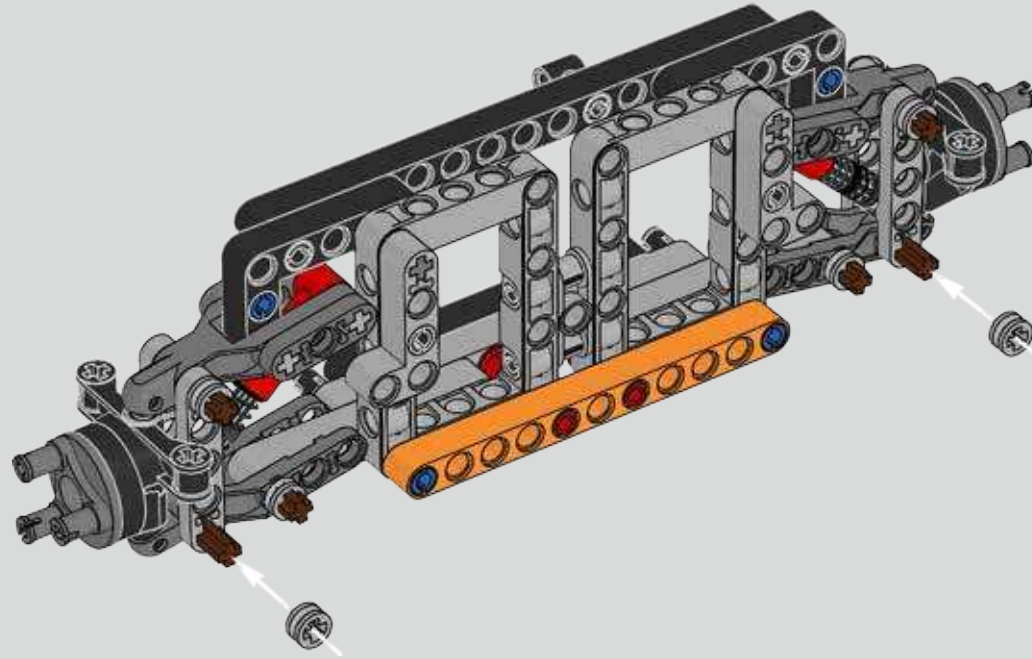

198

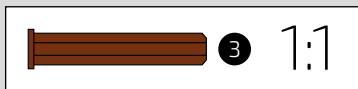
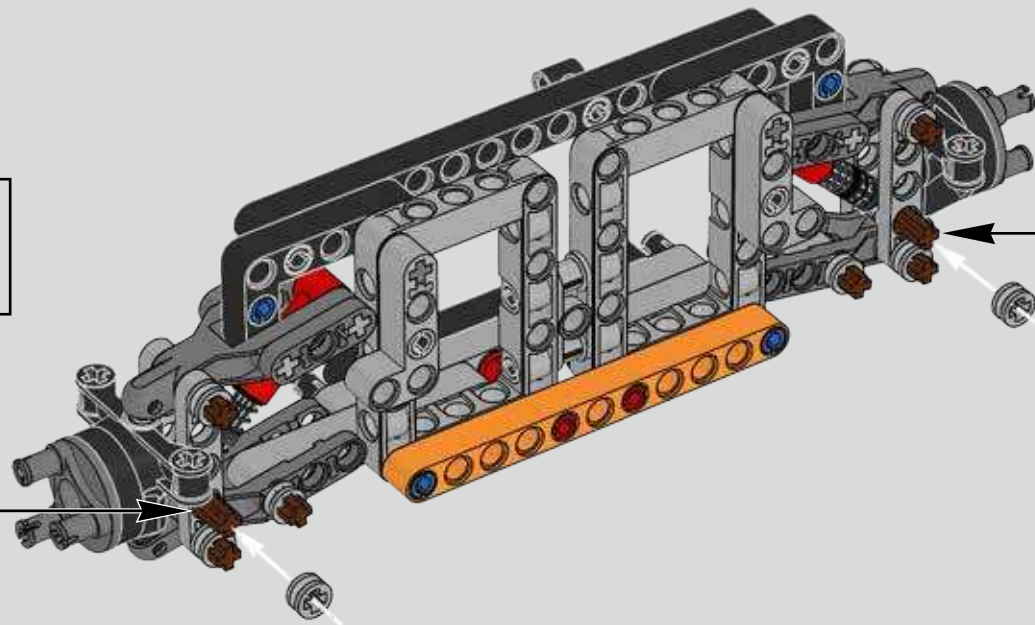
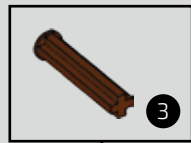

199

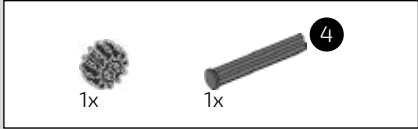
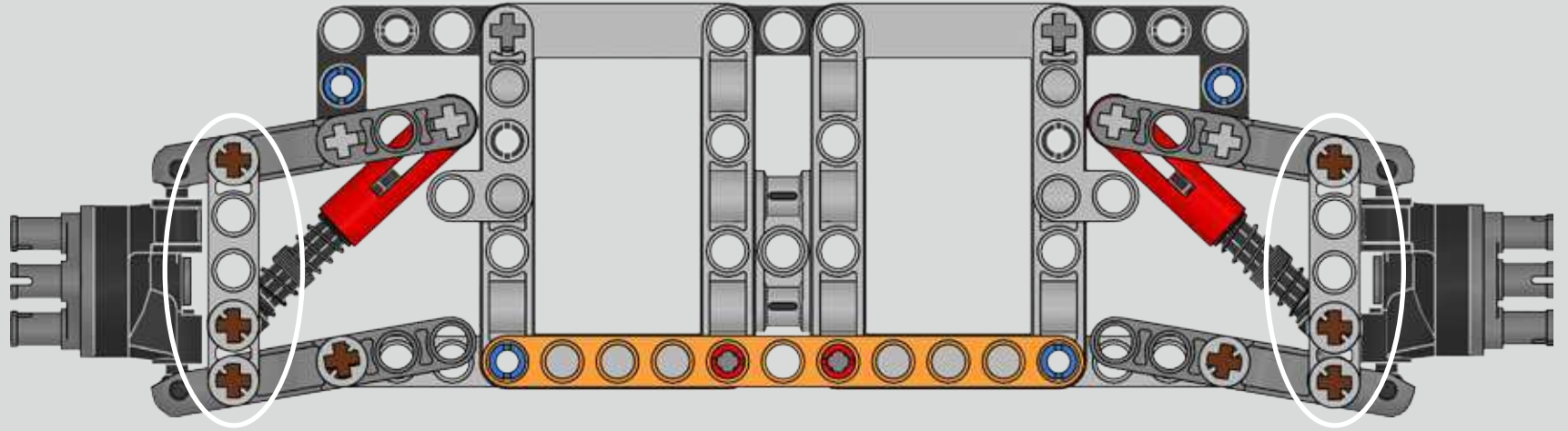

200

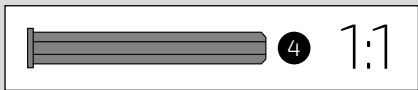
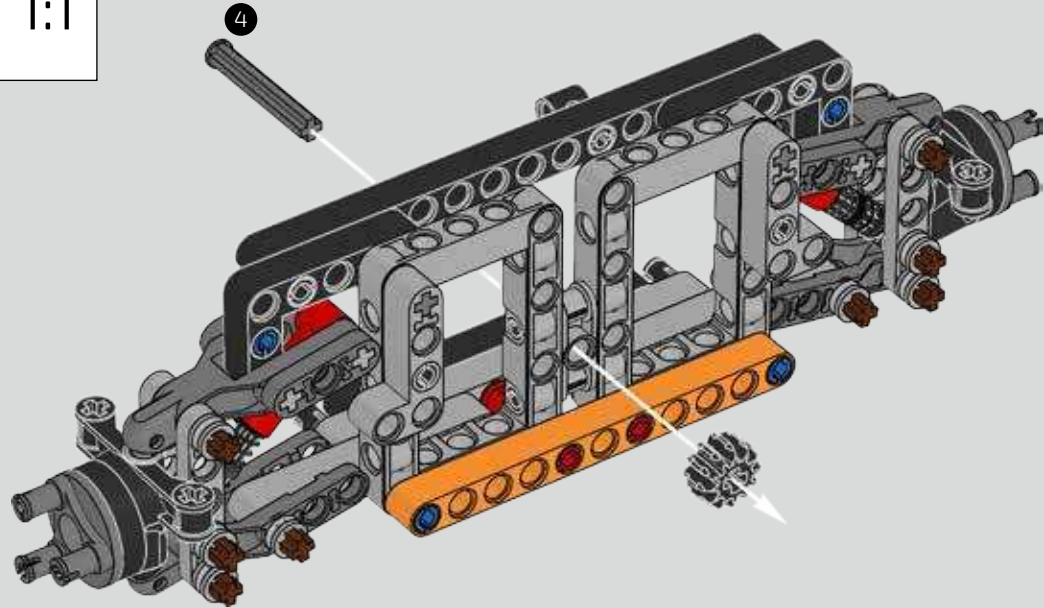

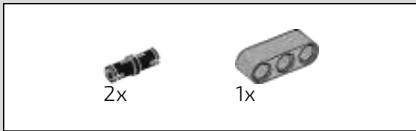

201

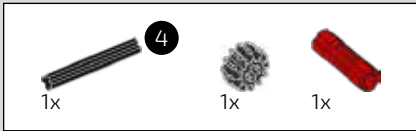
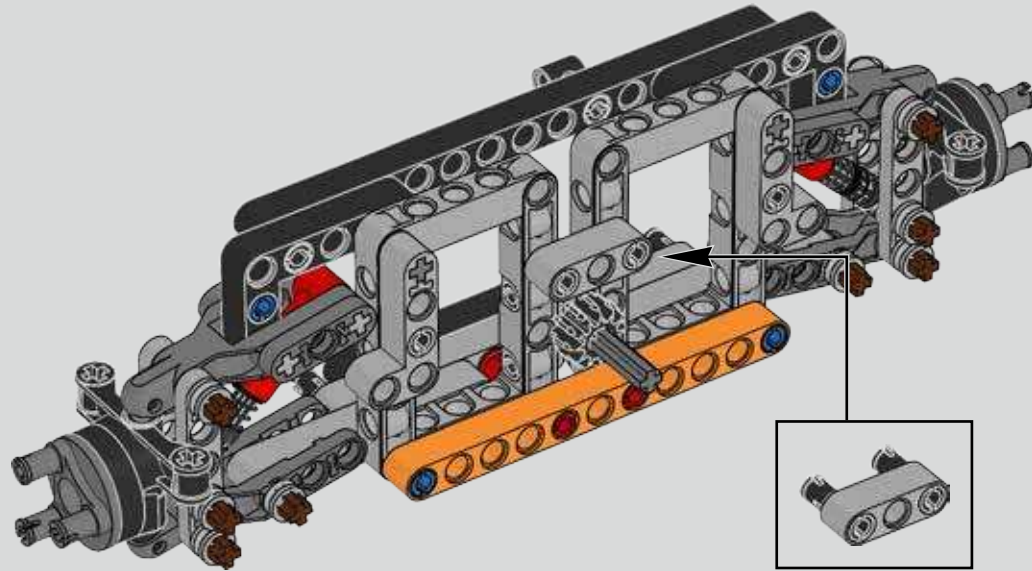

202

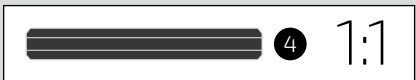
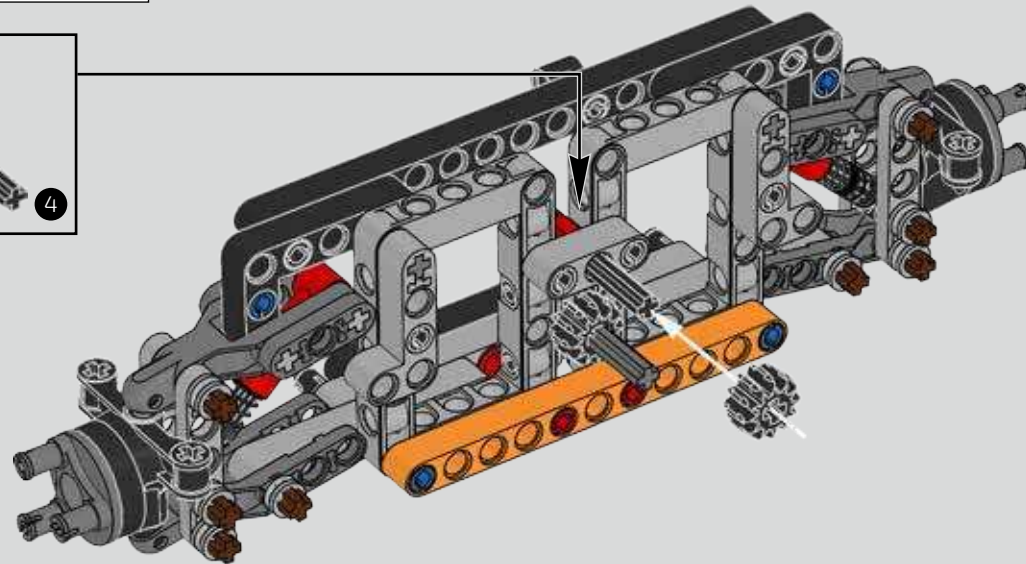
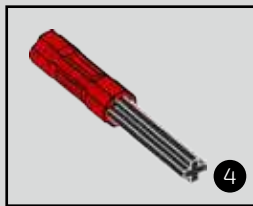

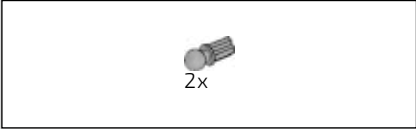

203

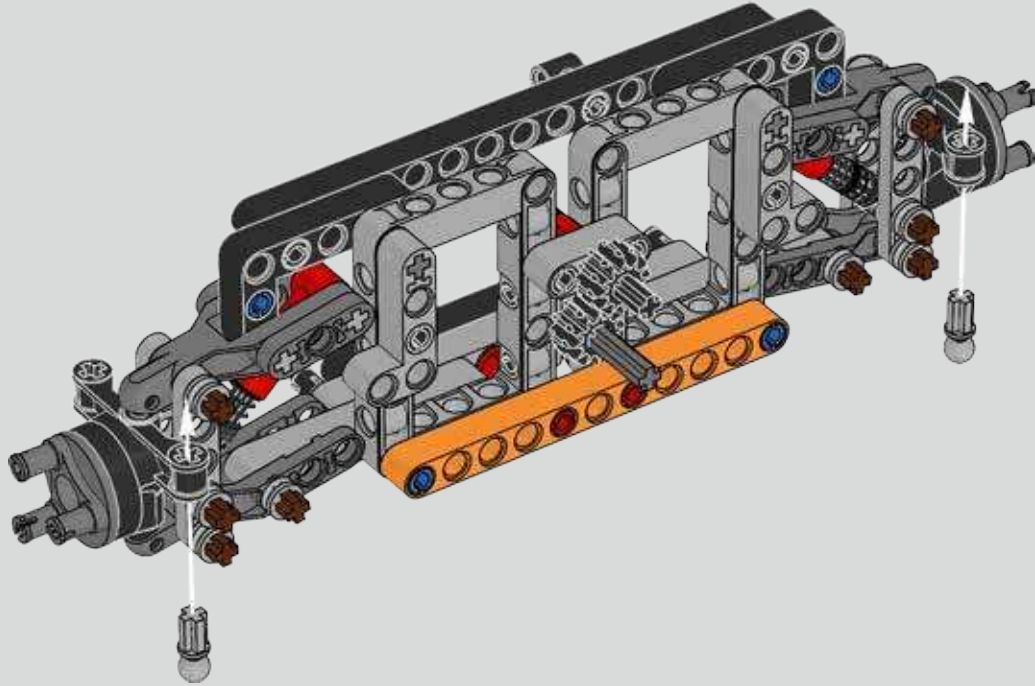

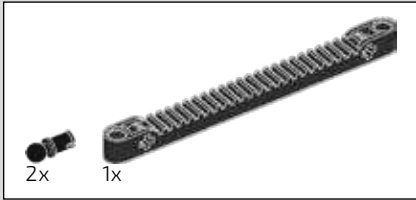
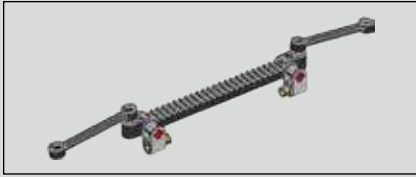

204

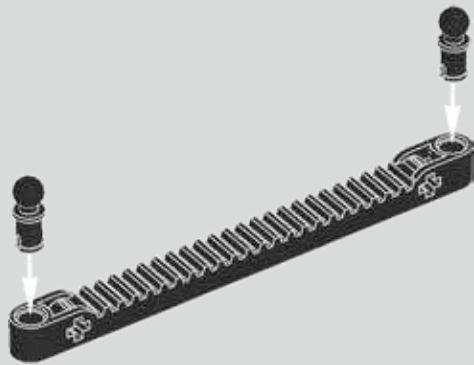

205

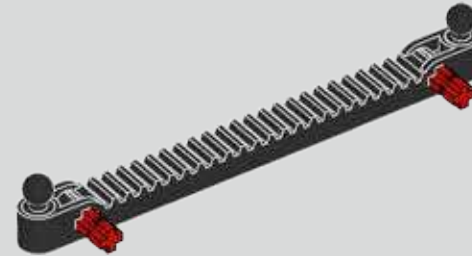

206

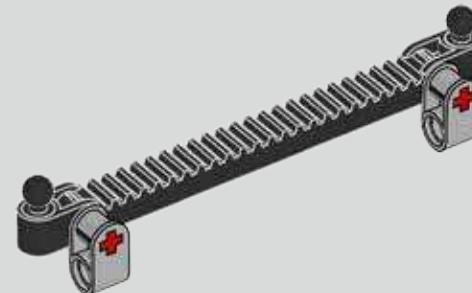



207

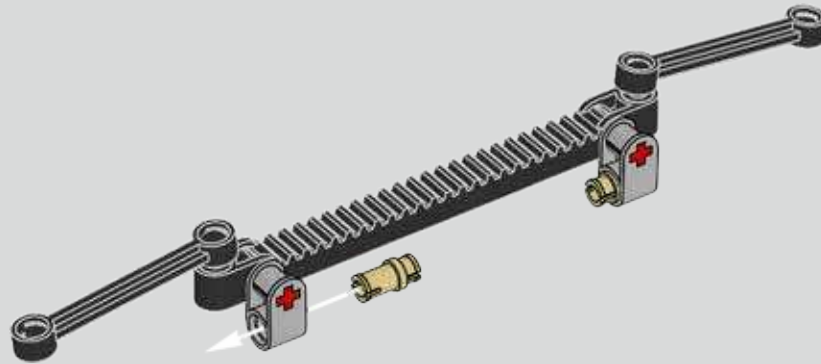

208

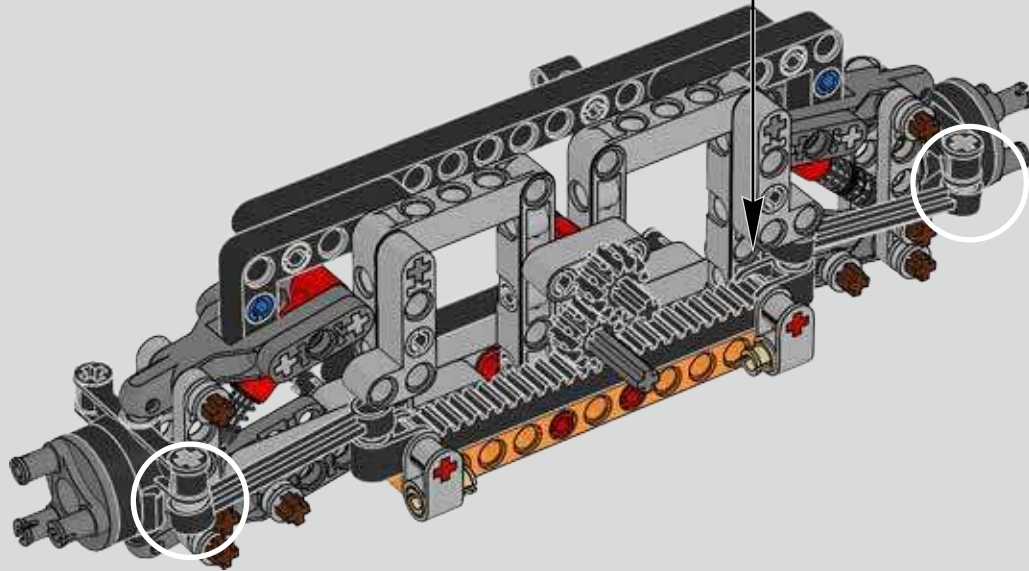

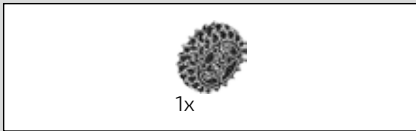

209

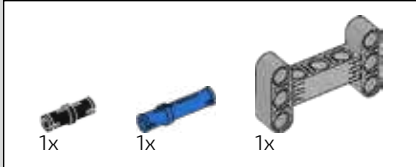
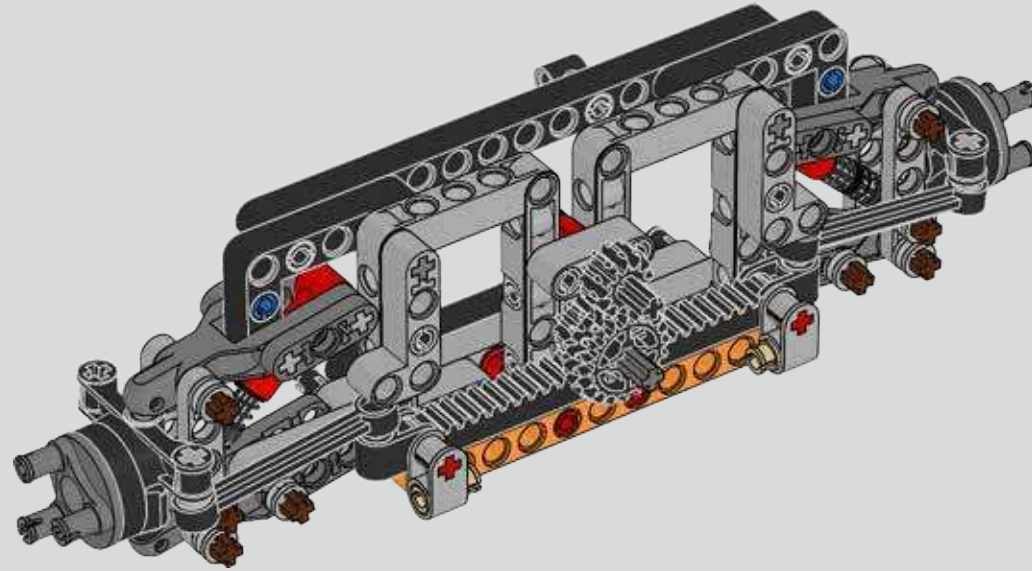

210

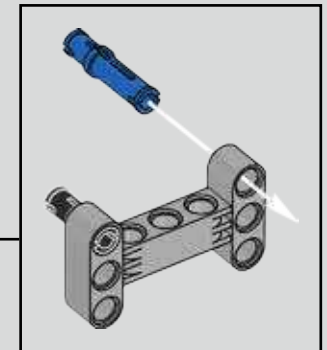
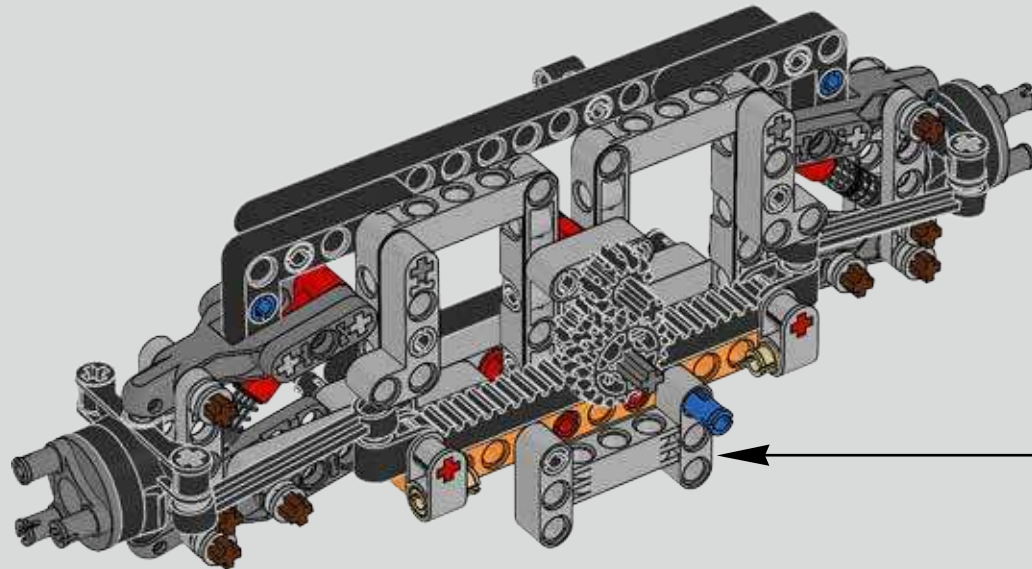

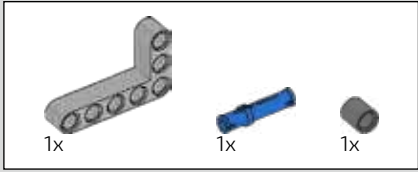

211

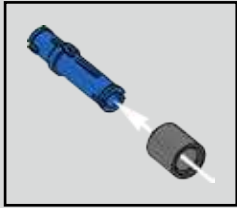
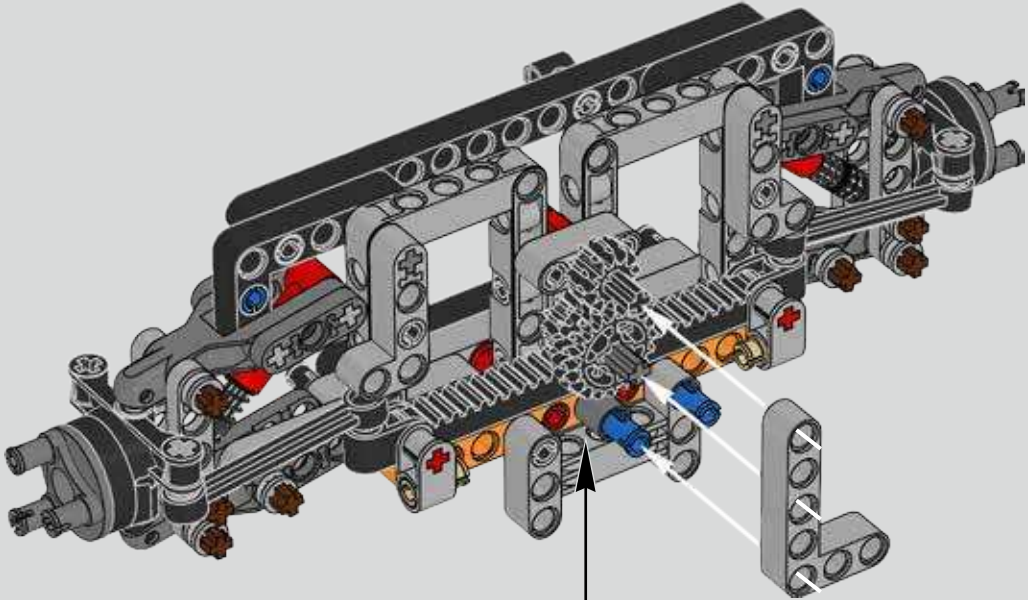

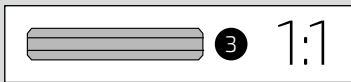
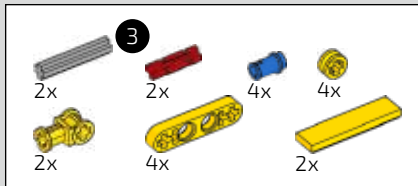

212

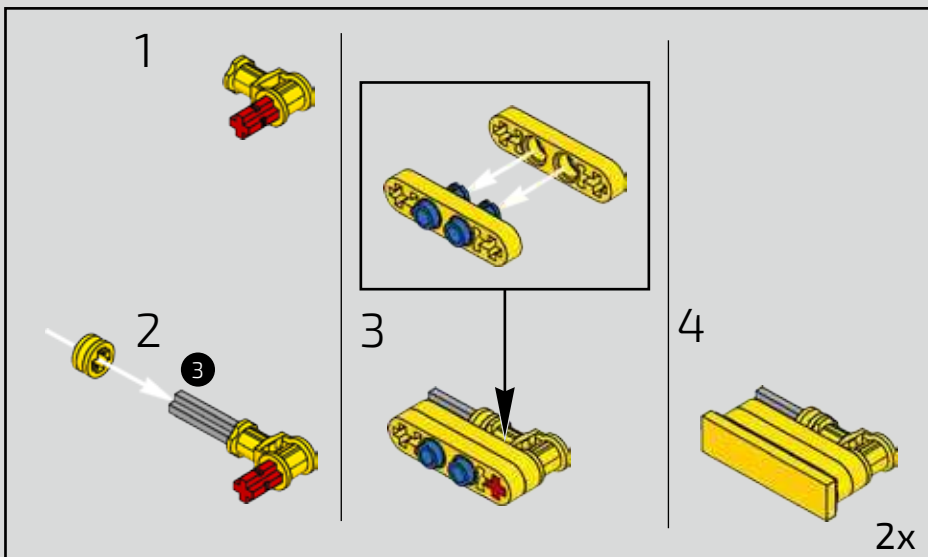
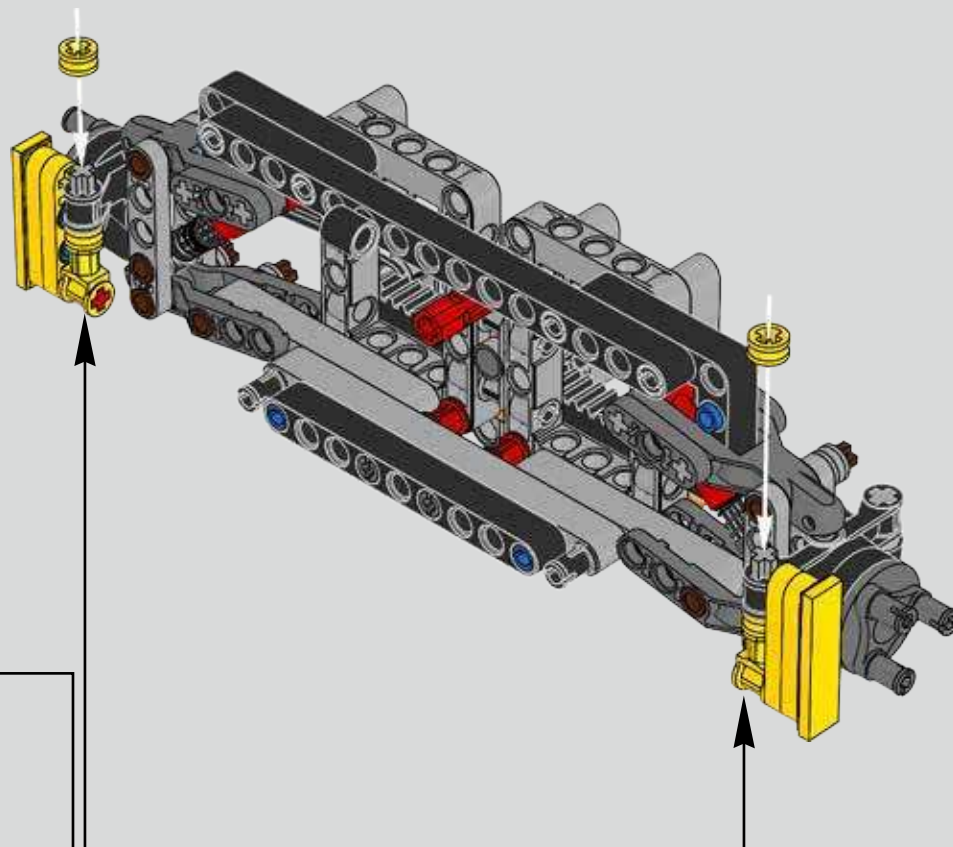
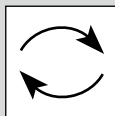

213

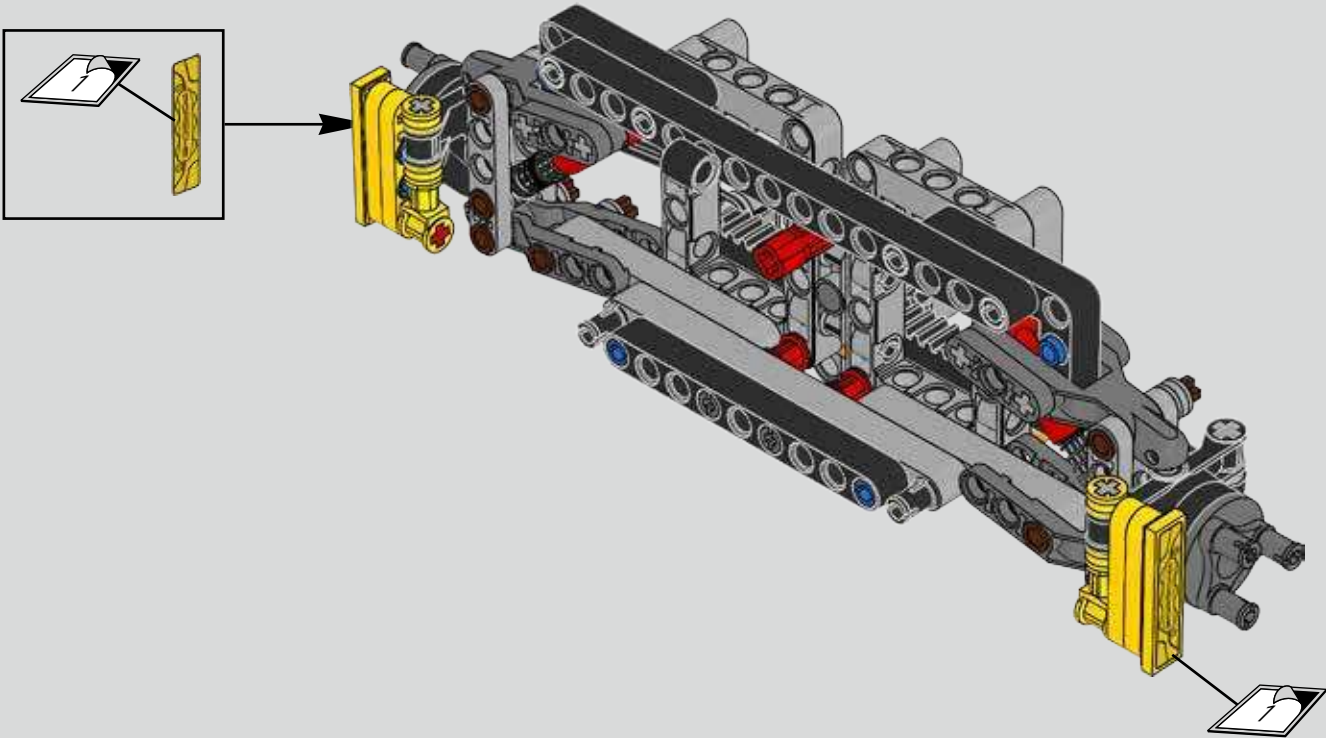

214

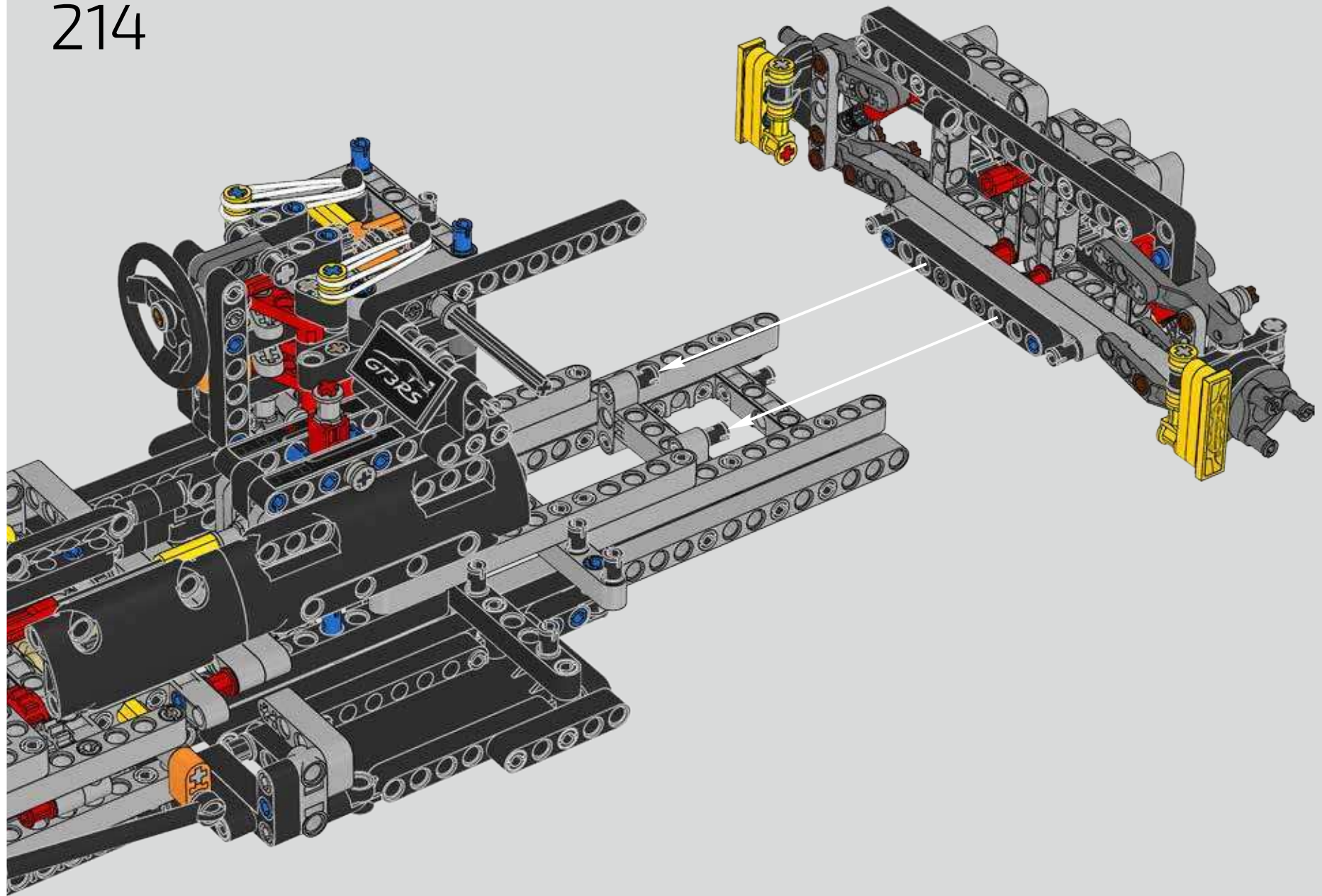

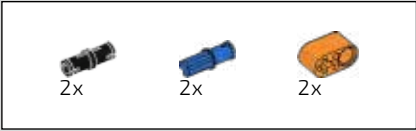

215

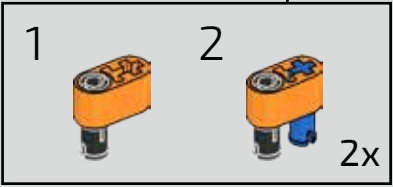
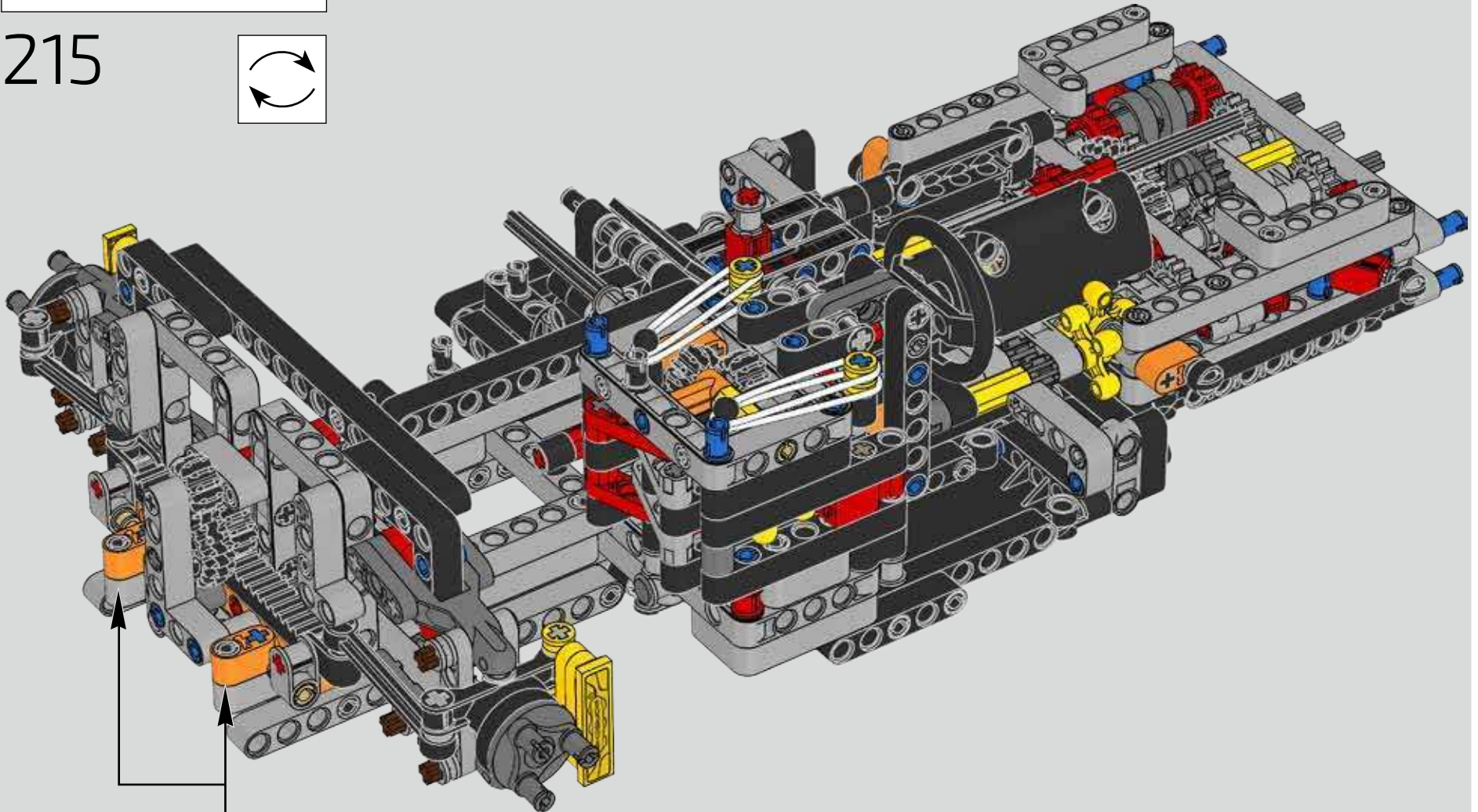
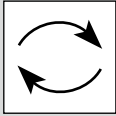

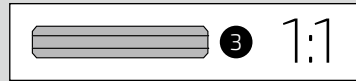
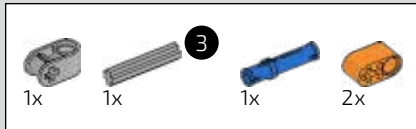

216

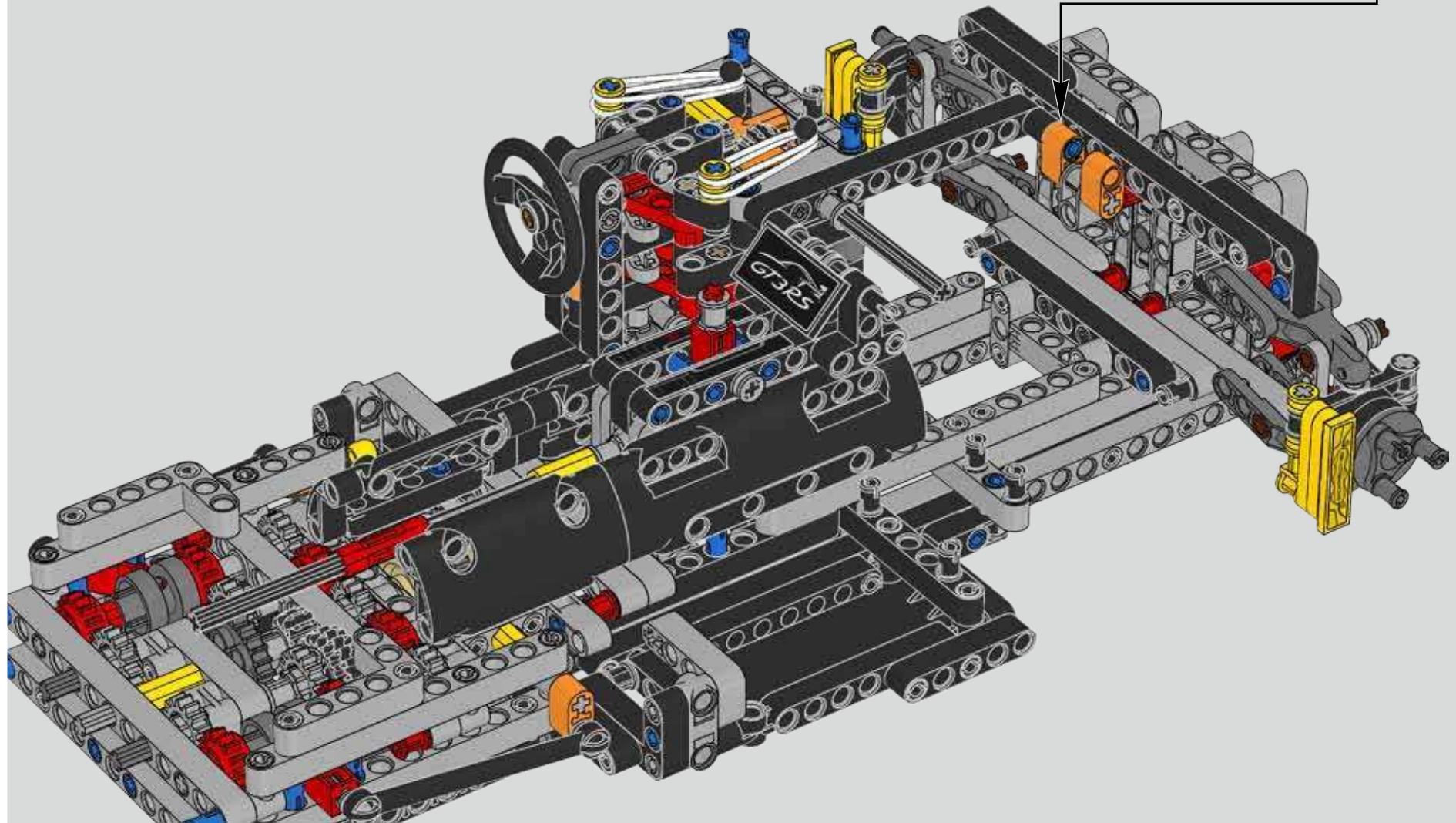
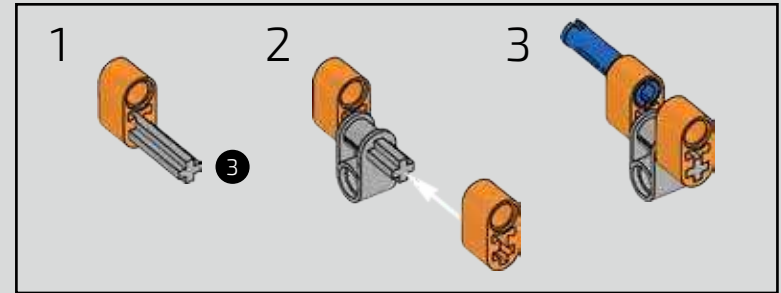
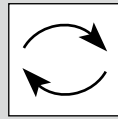

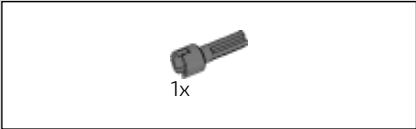

217

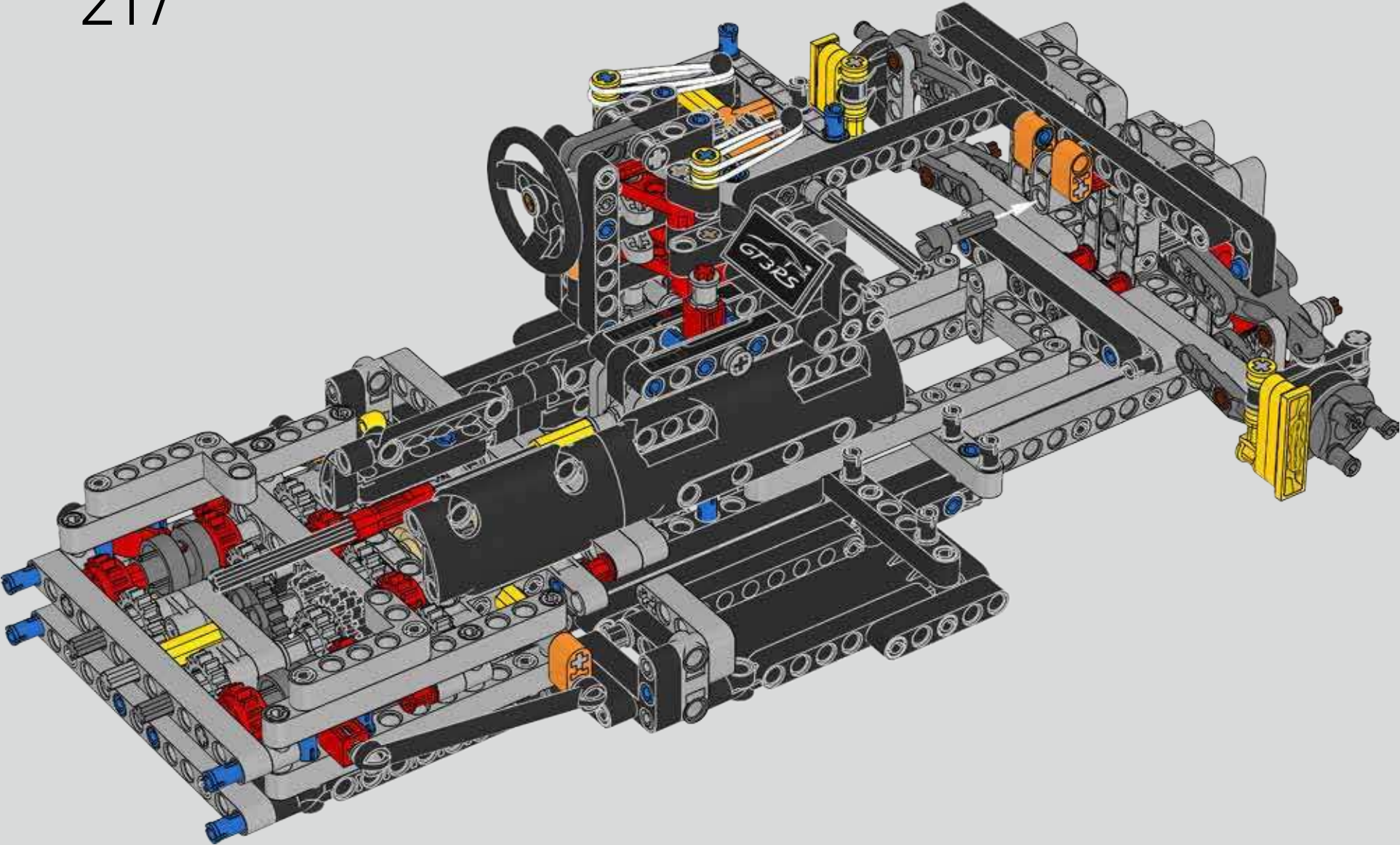

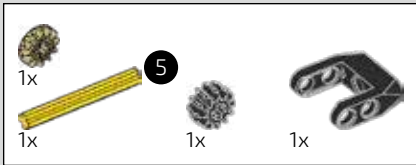

218

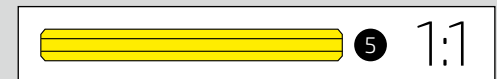
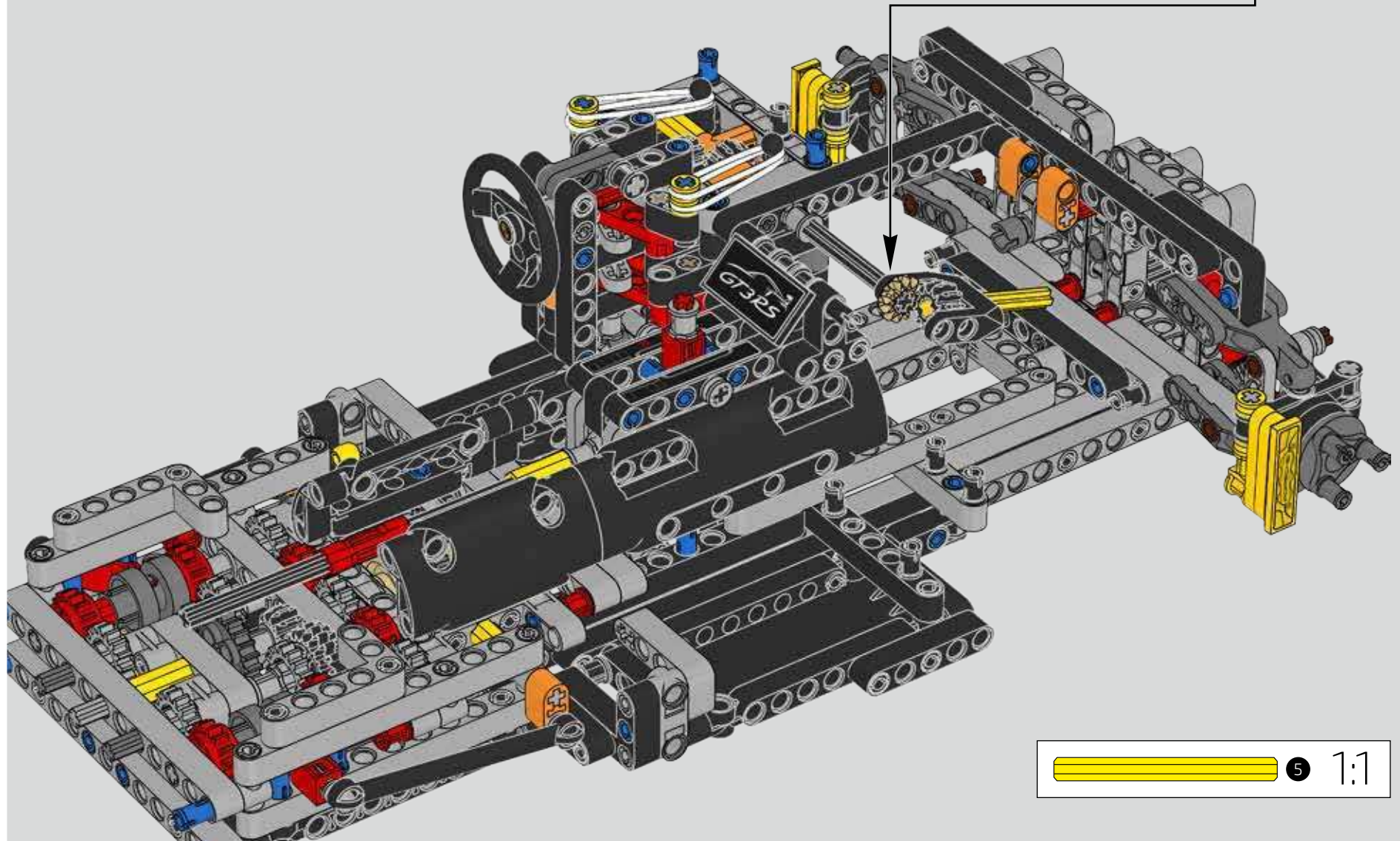
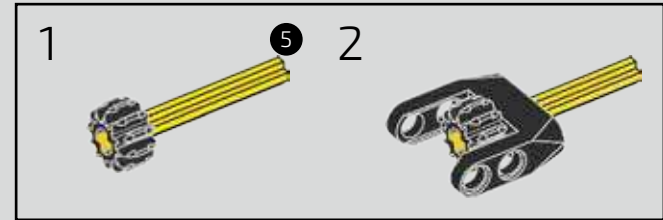



219

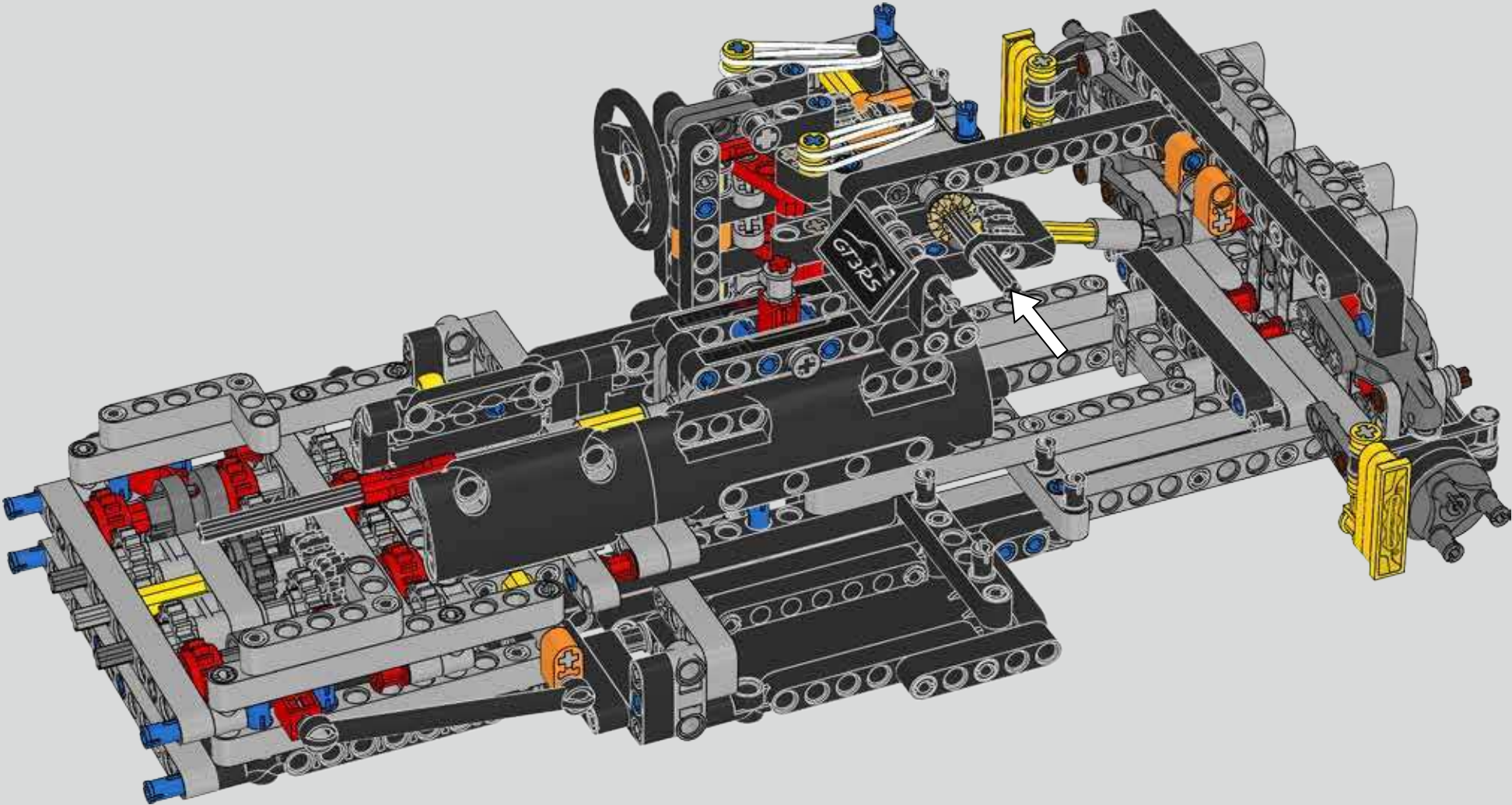

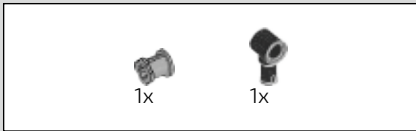

220

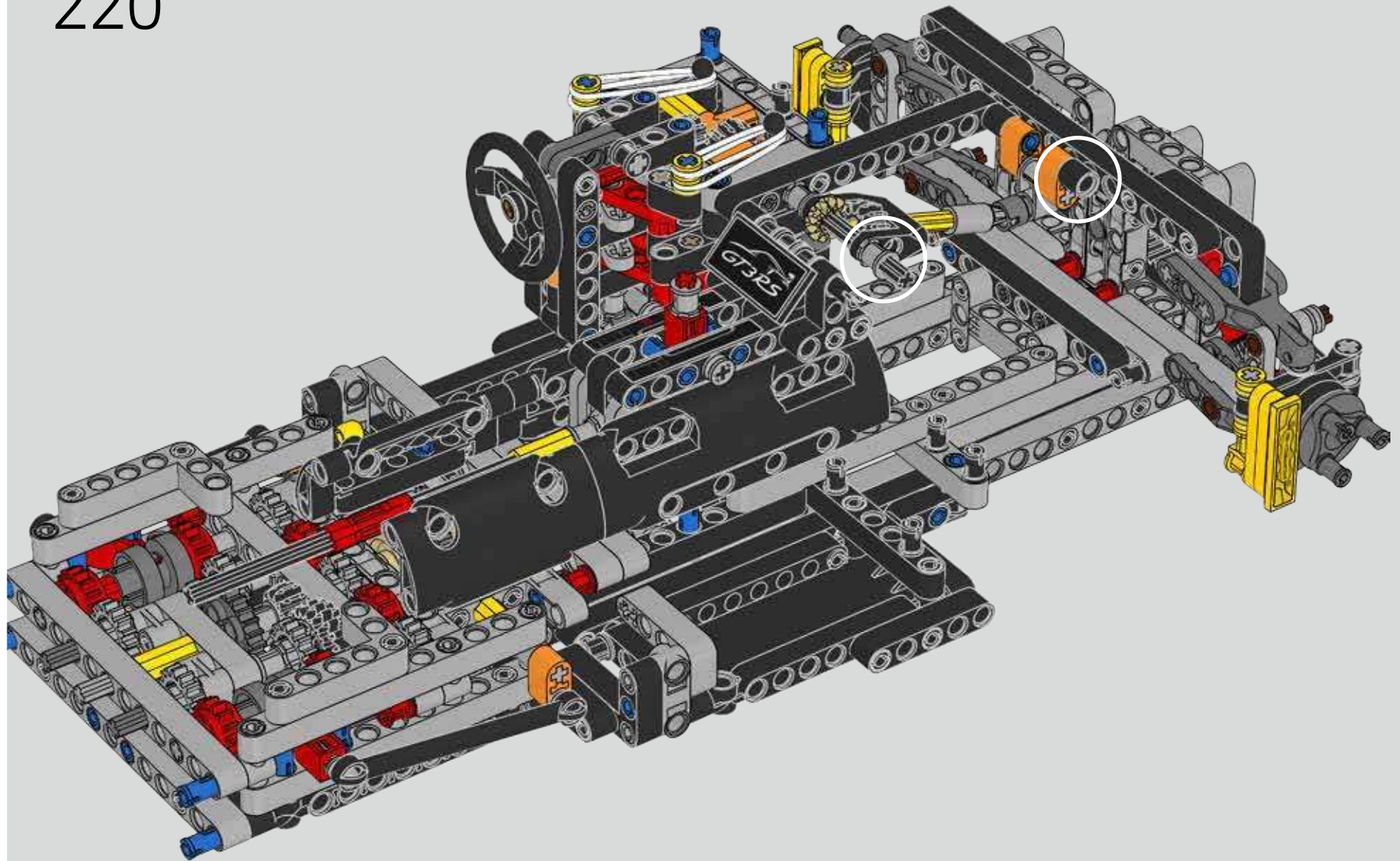

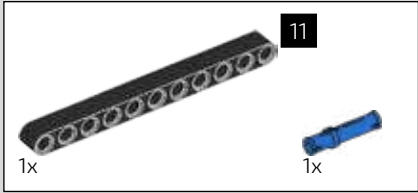

221

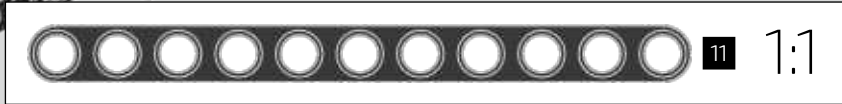
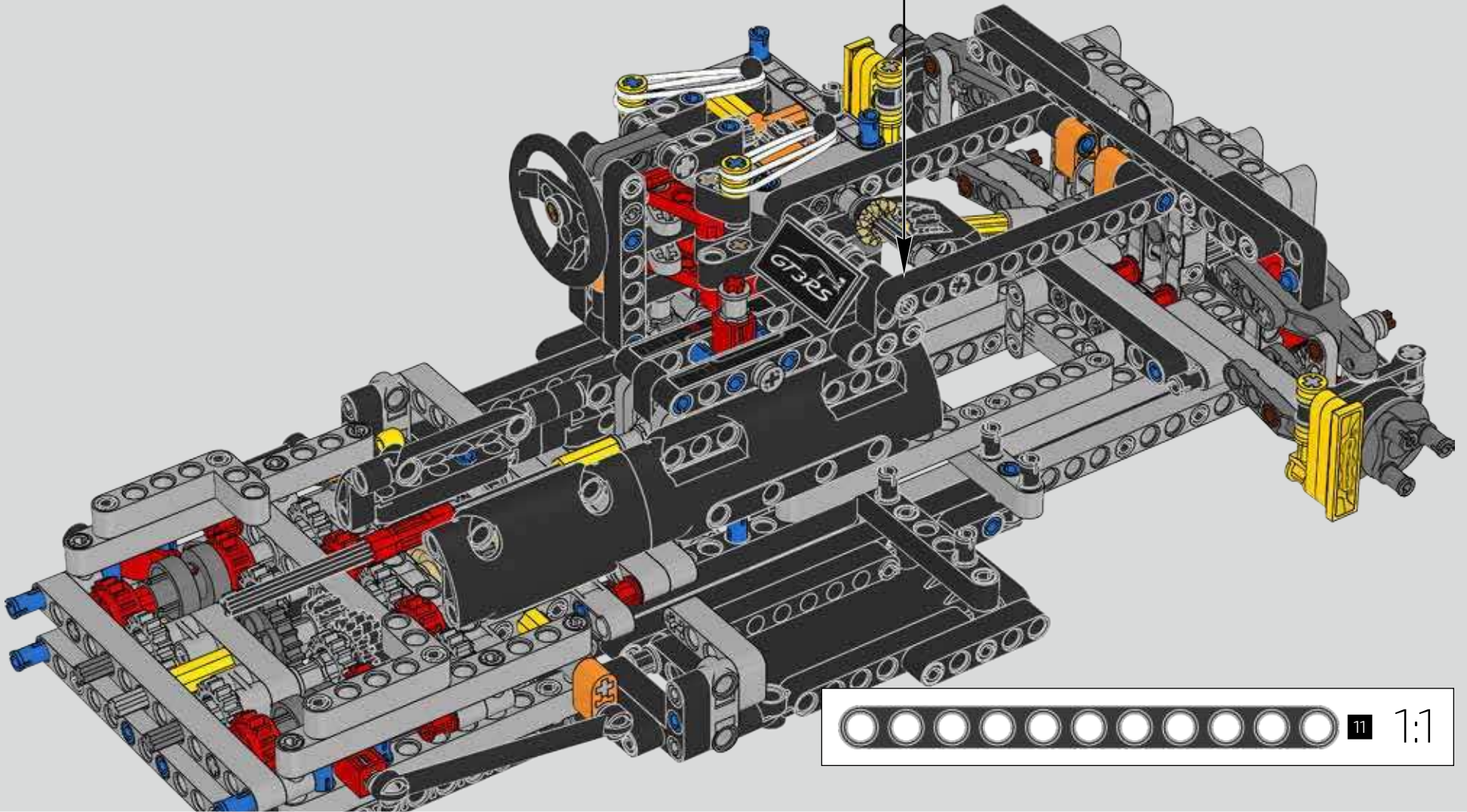
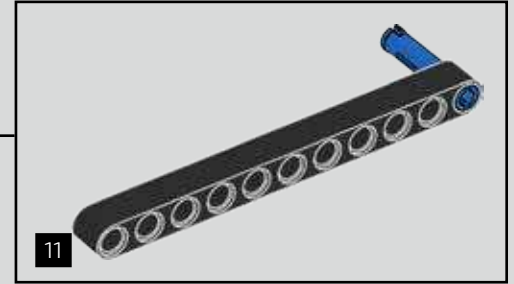

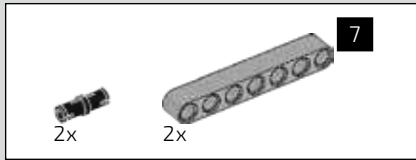

222

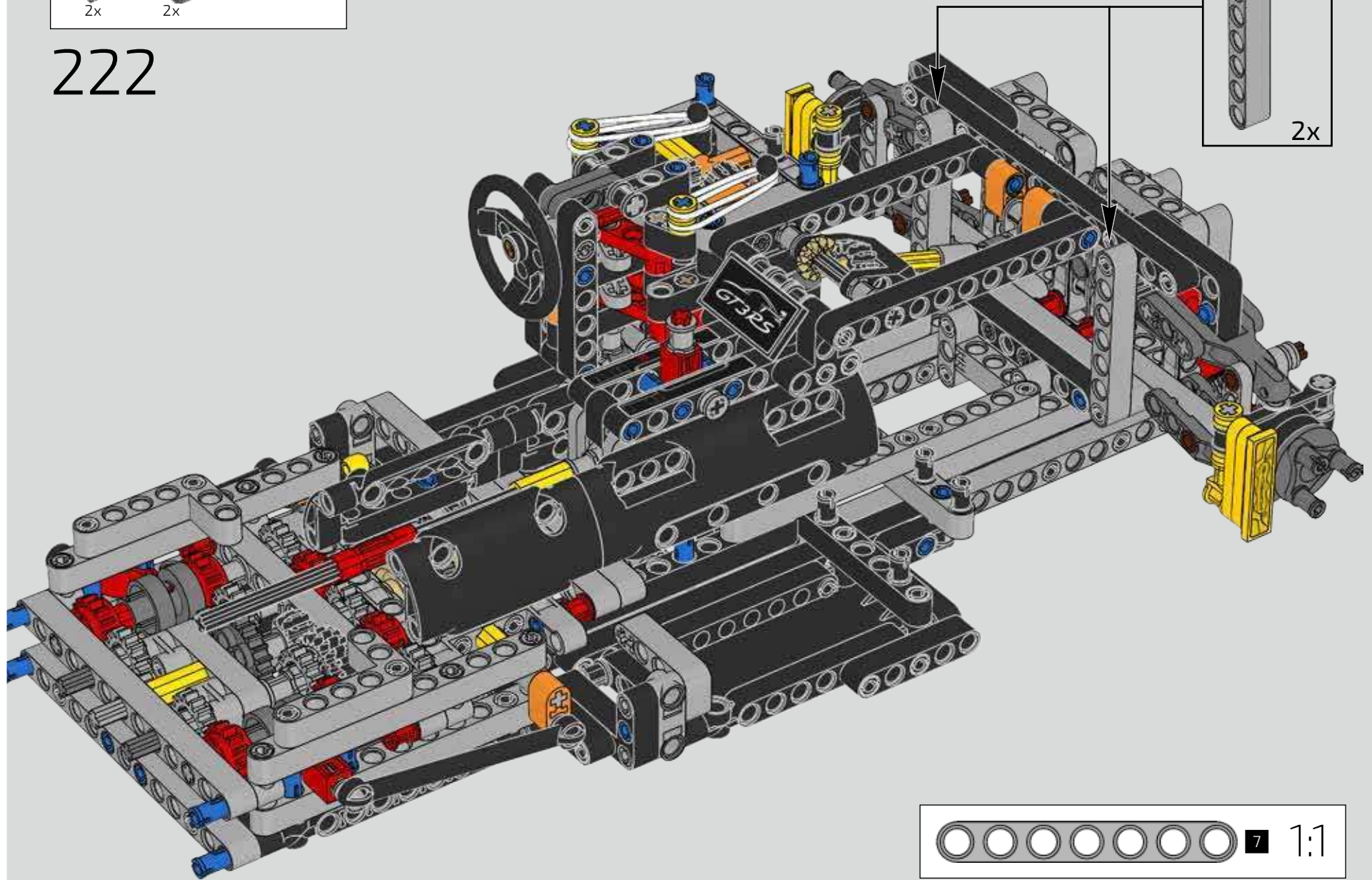
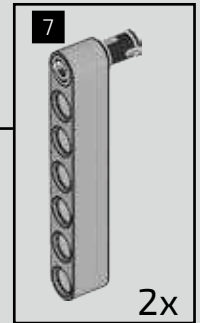

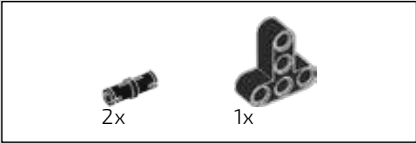

223

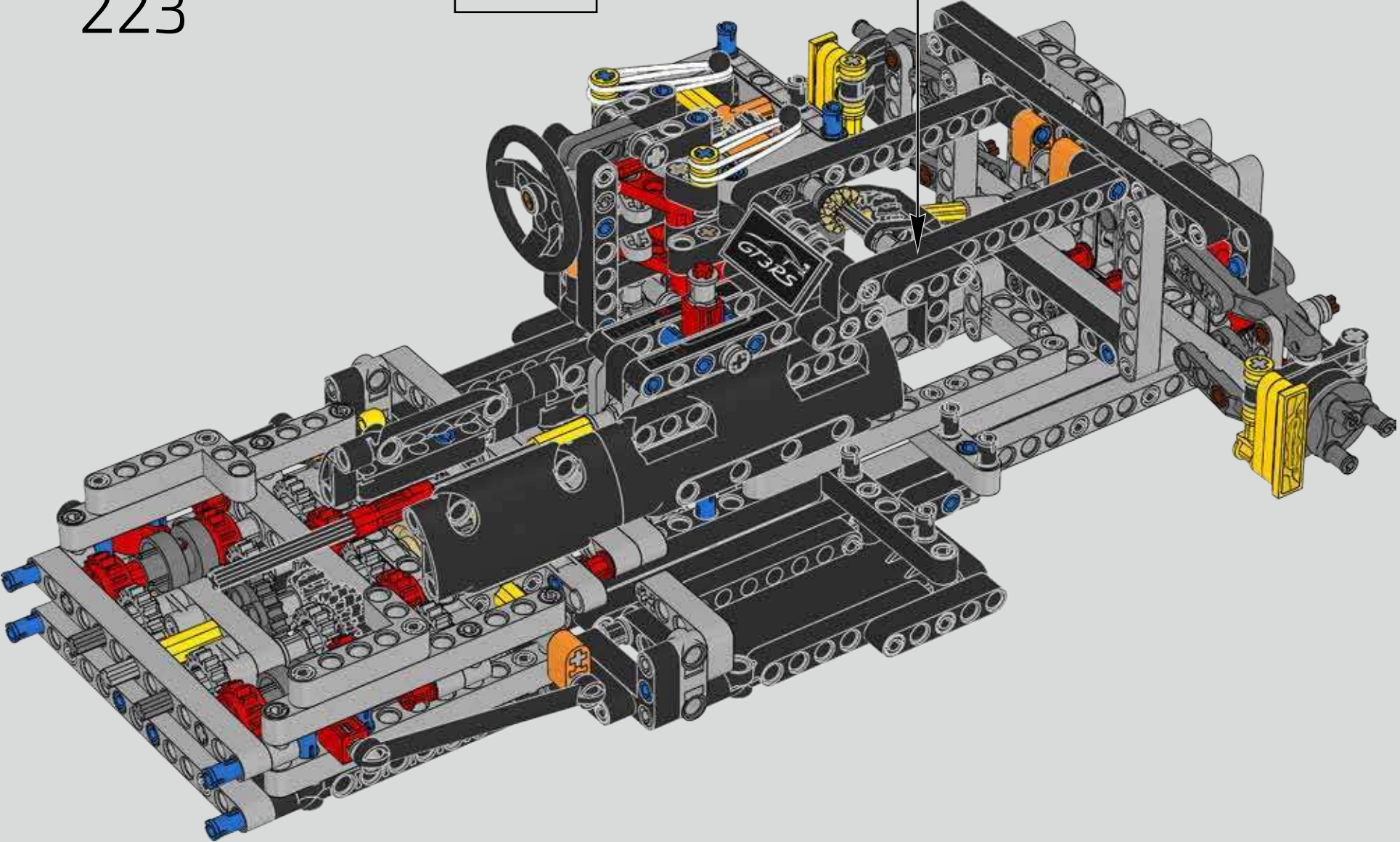

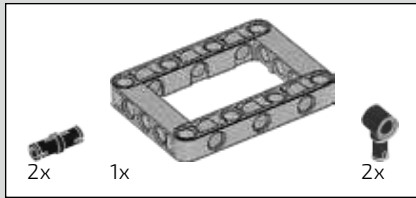

224

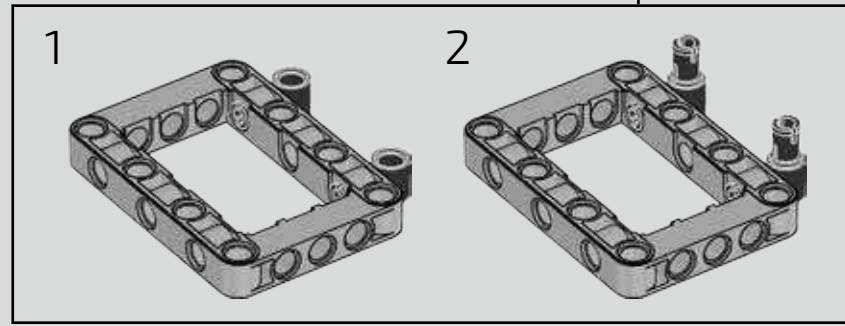
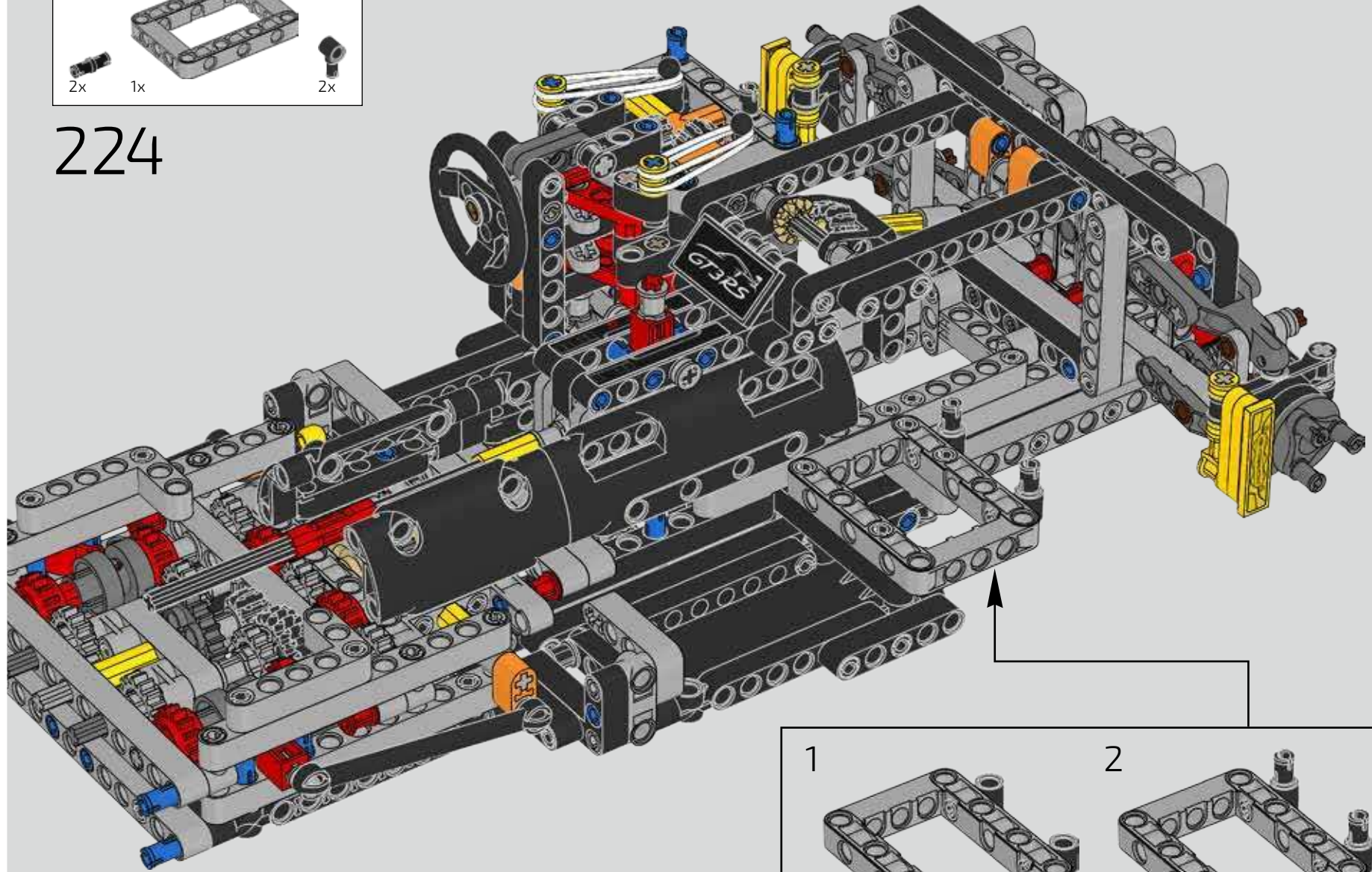

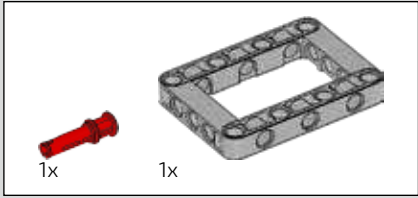

225

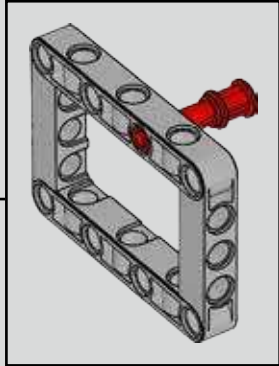
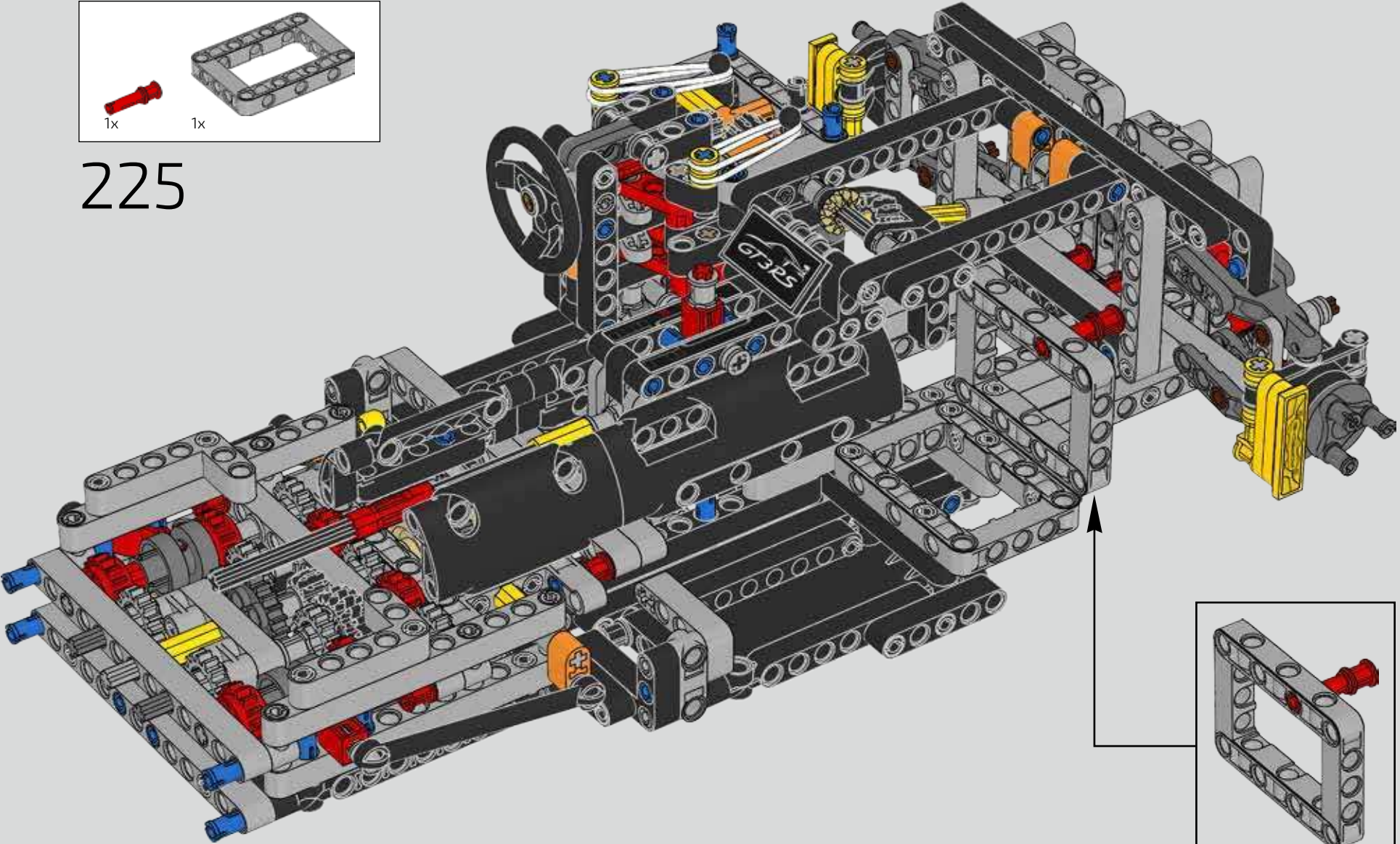



226

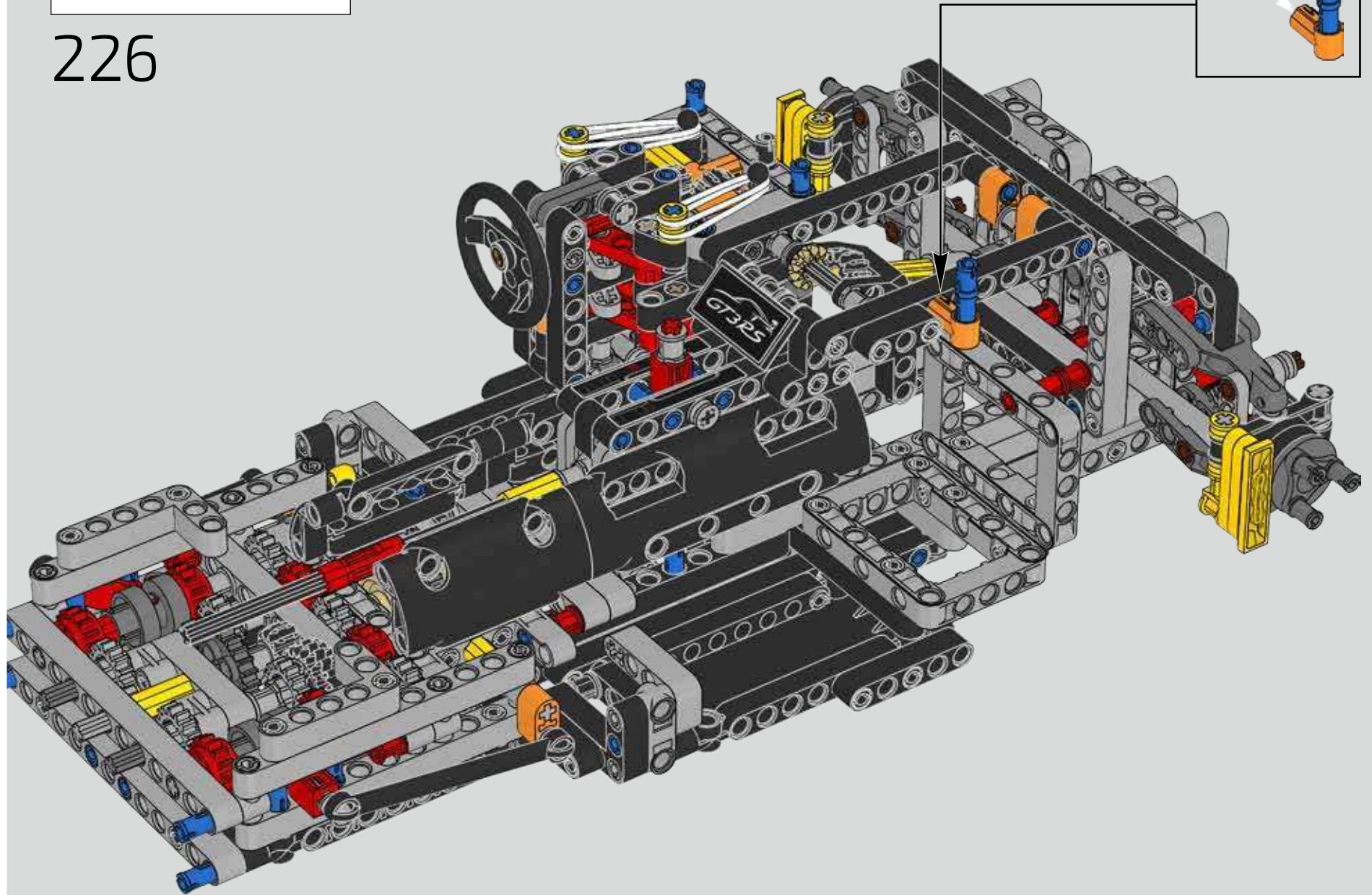
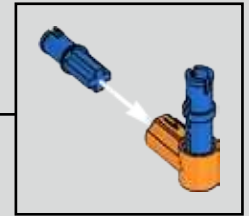

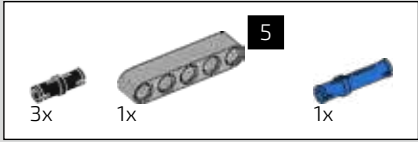

227

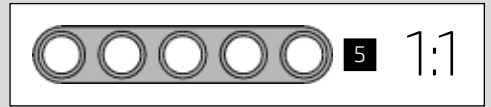
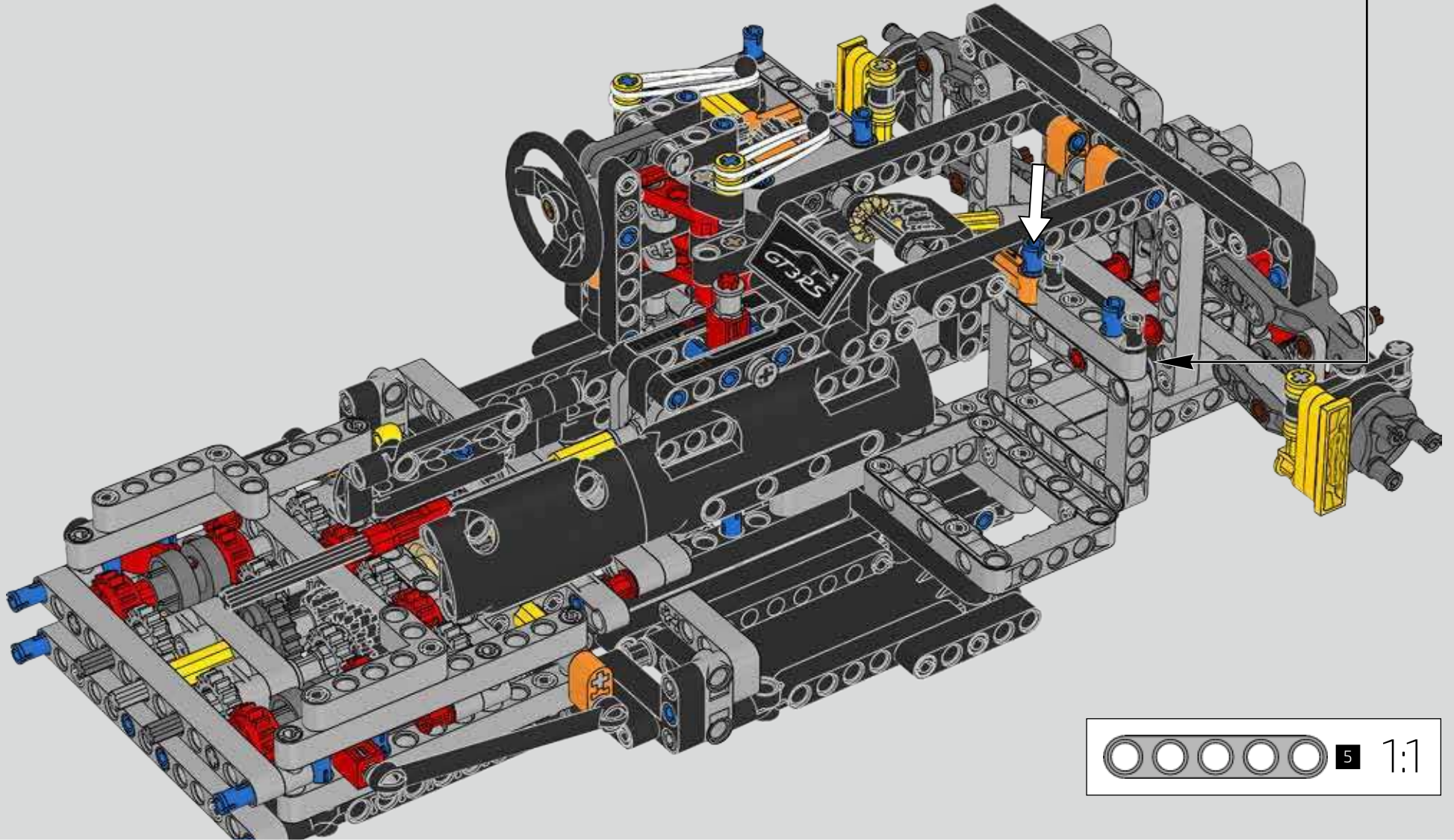
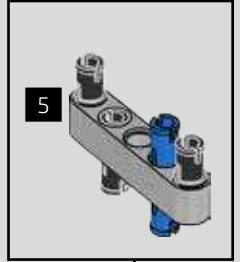

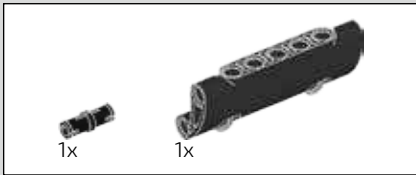
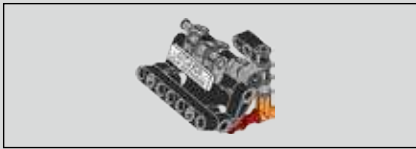

228

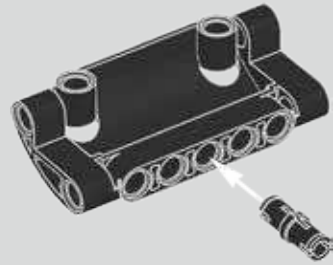

229

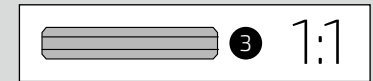
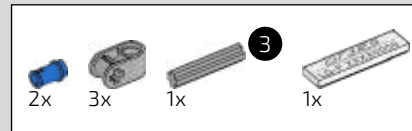
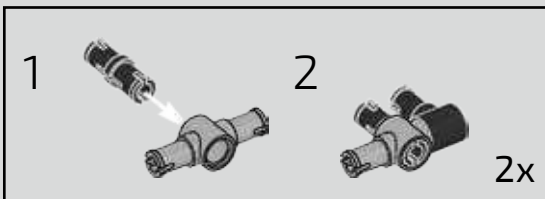
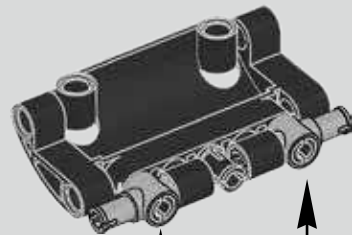

230

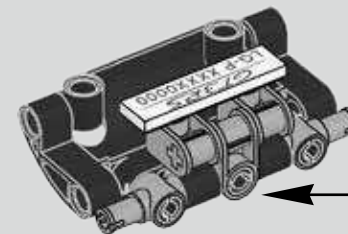
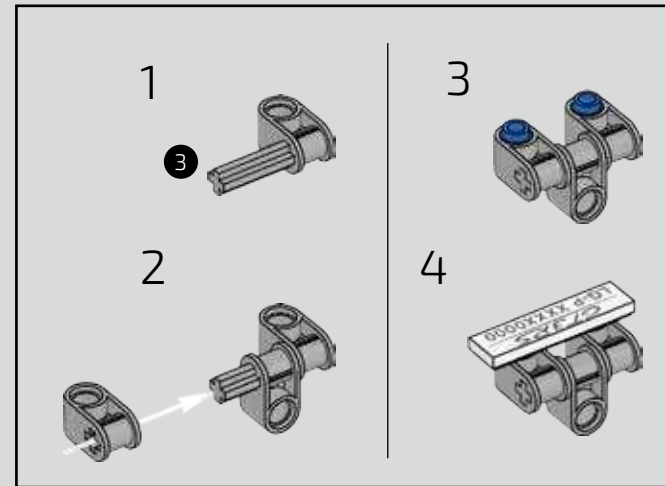

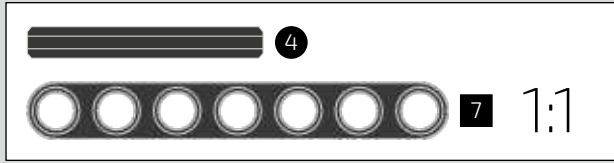
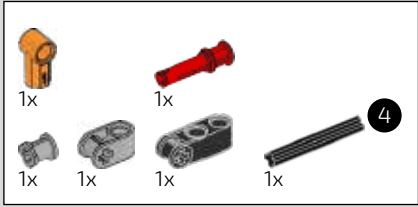

231

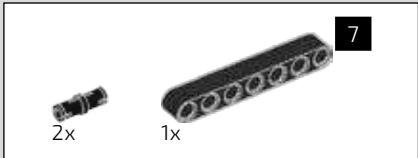
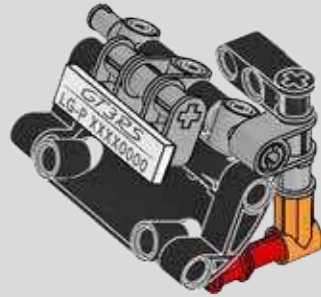
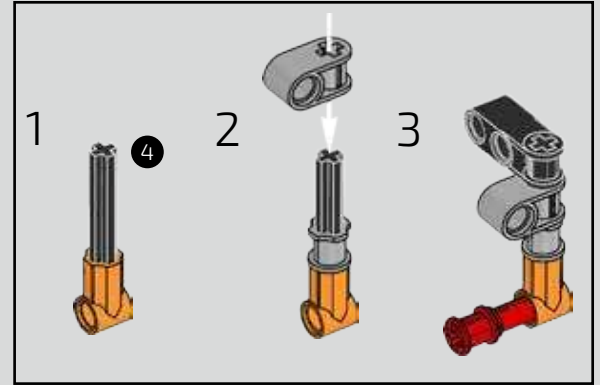
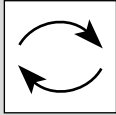

232

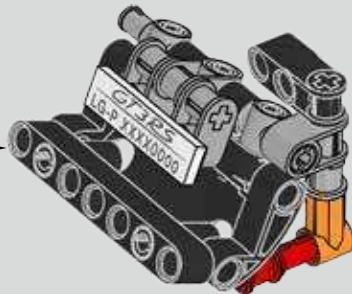
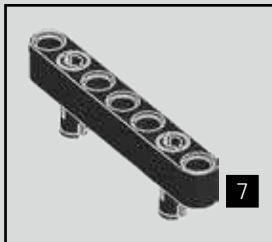

233

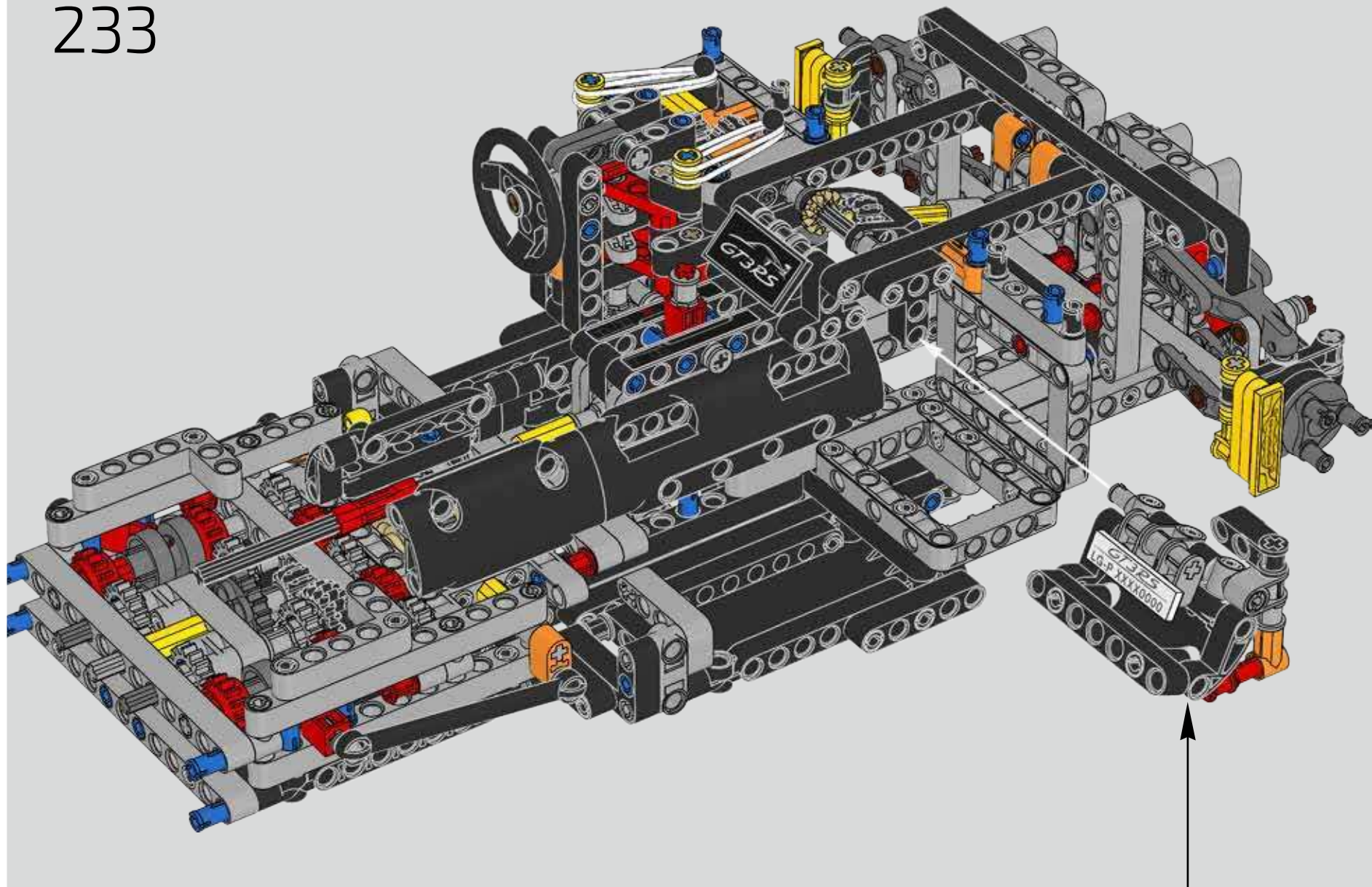

234

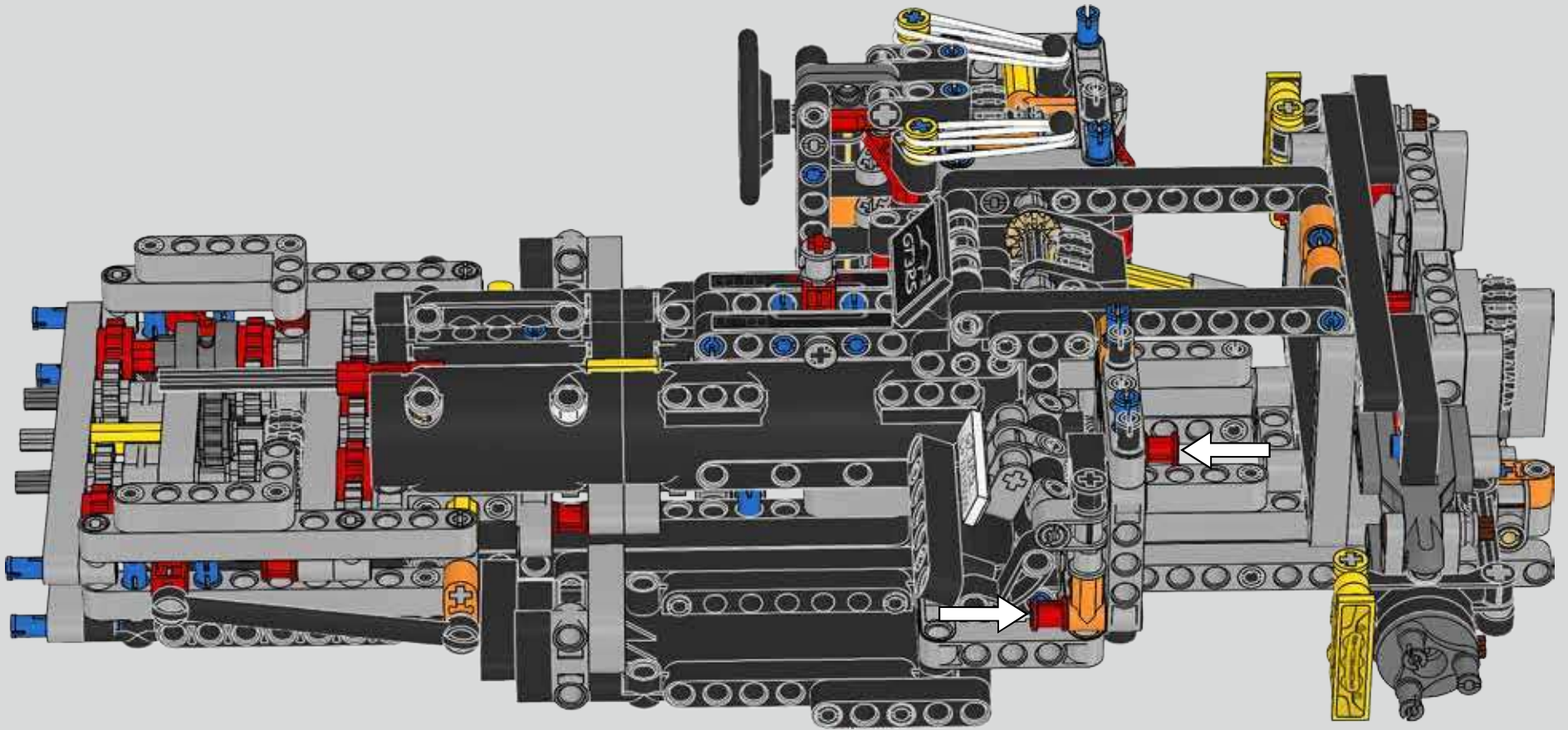

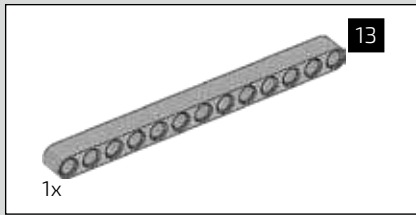

235

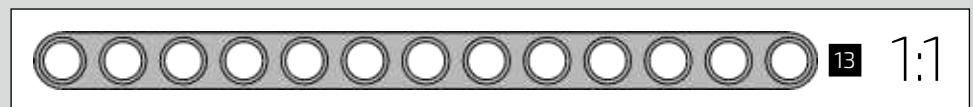
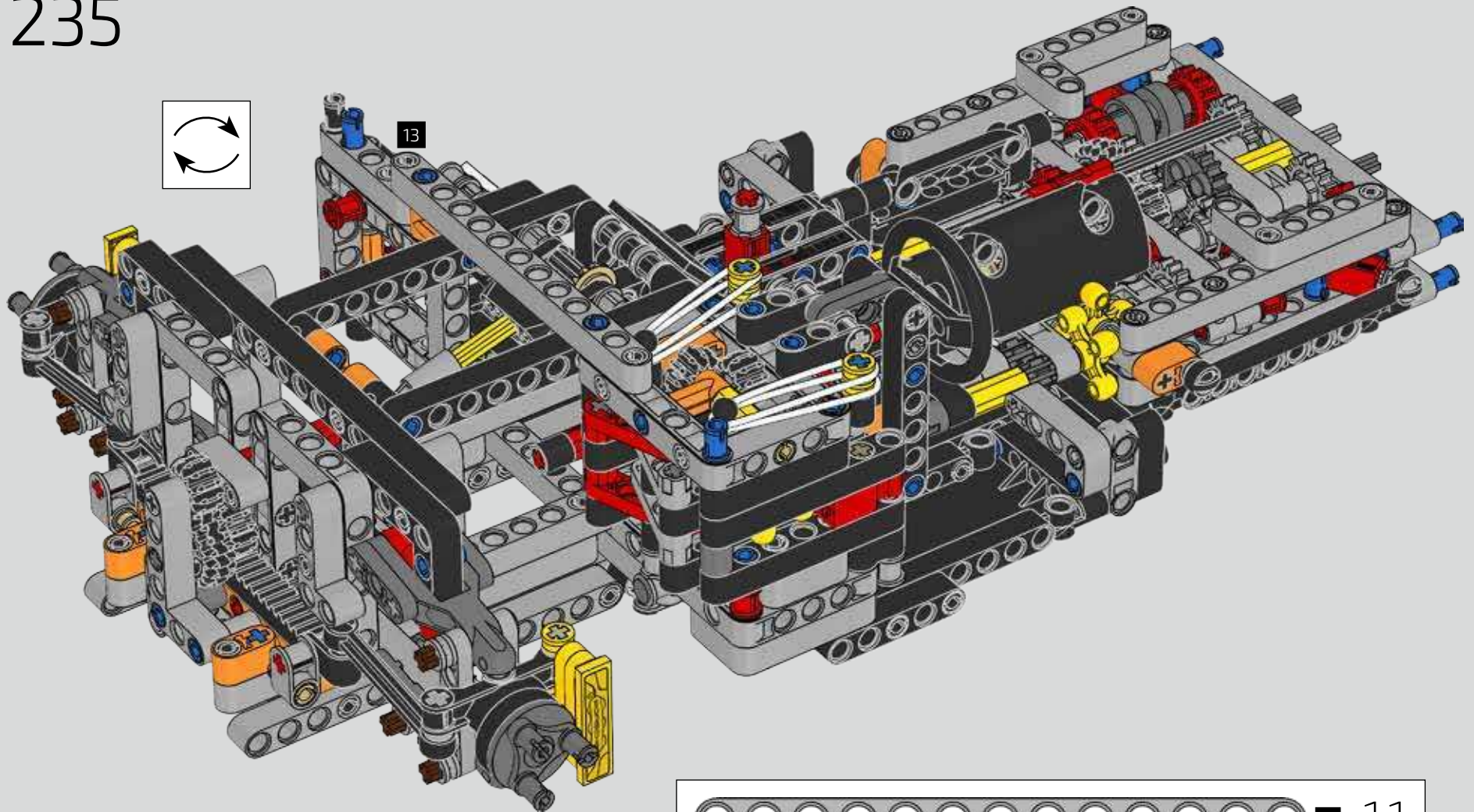
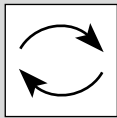

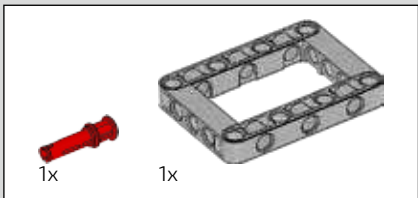
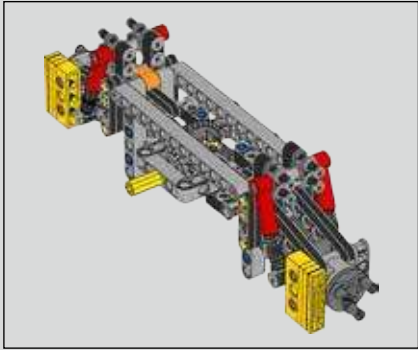

236

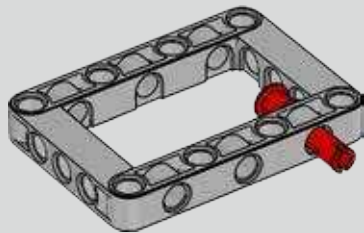

237

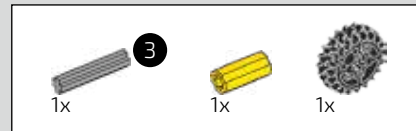
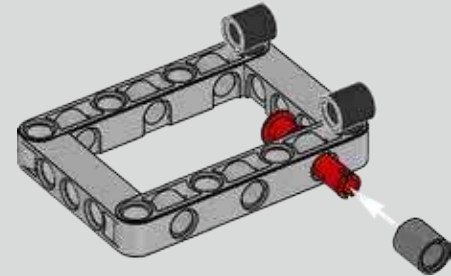

238

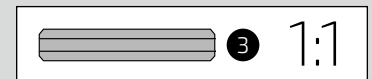
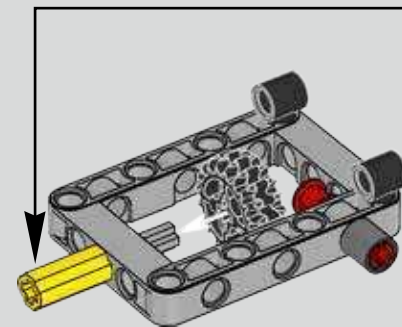
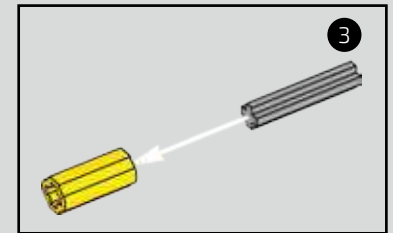

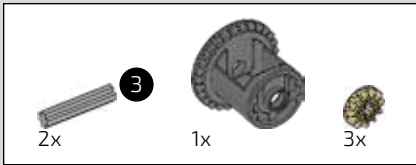

239

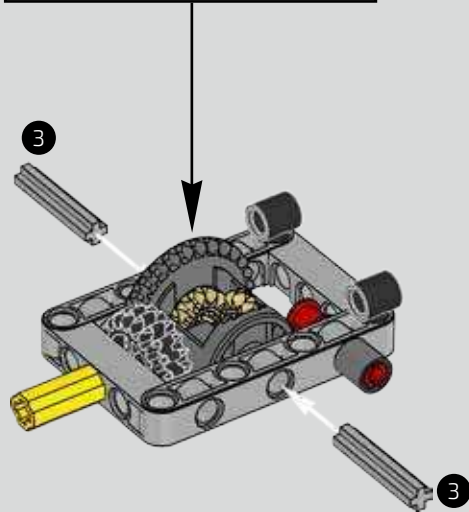
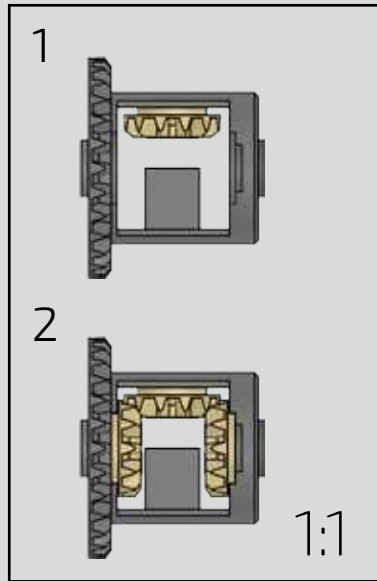

240

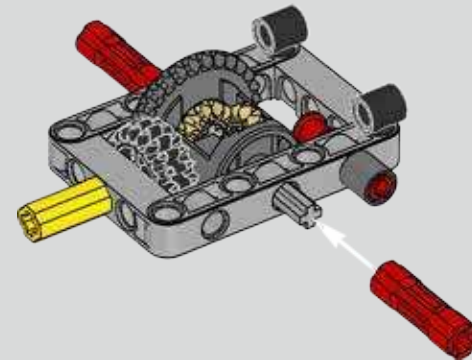

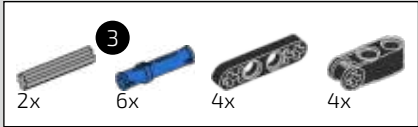

241

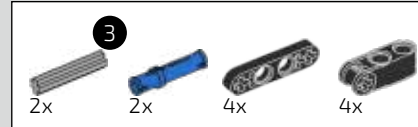
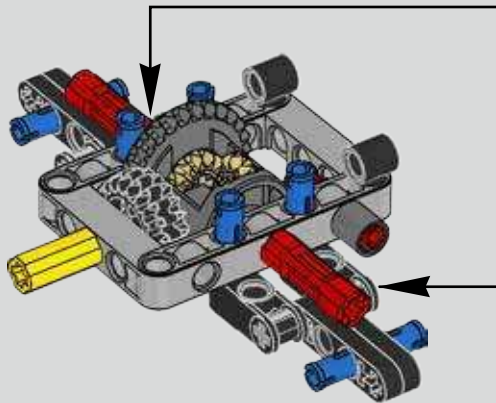
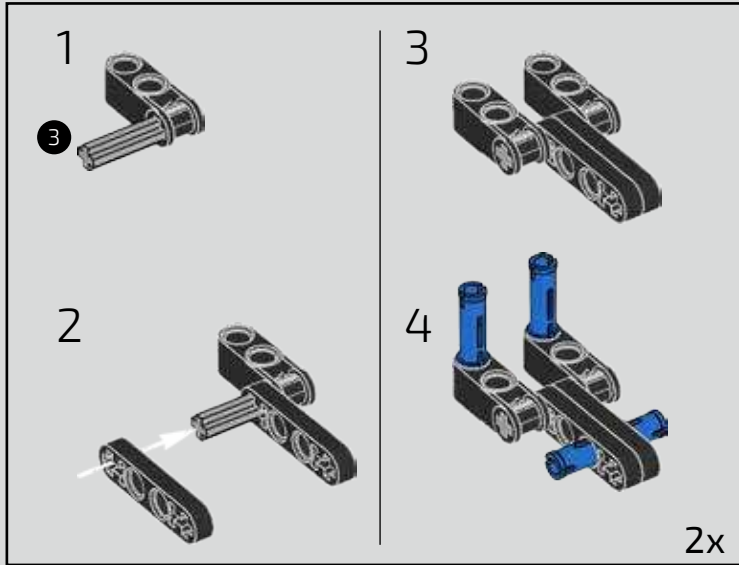

242

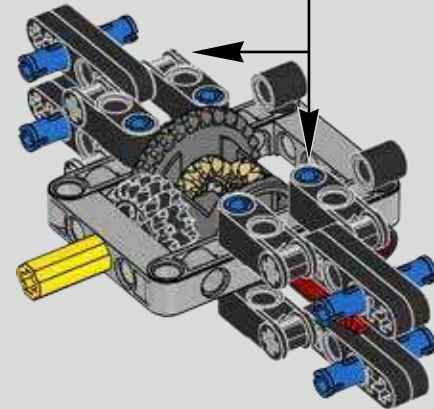
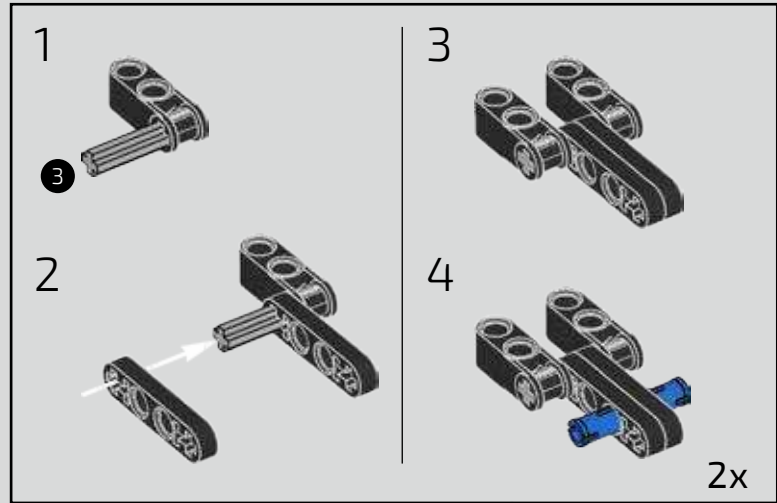

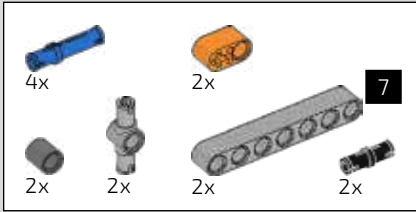

243

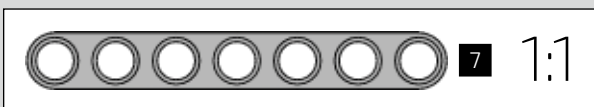
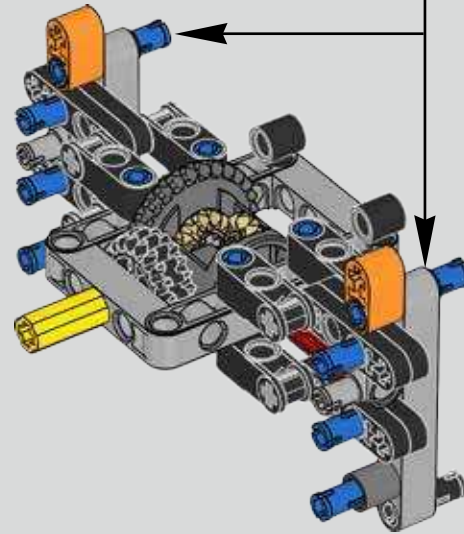
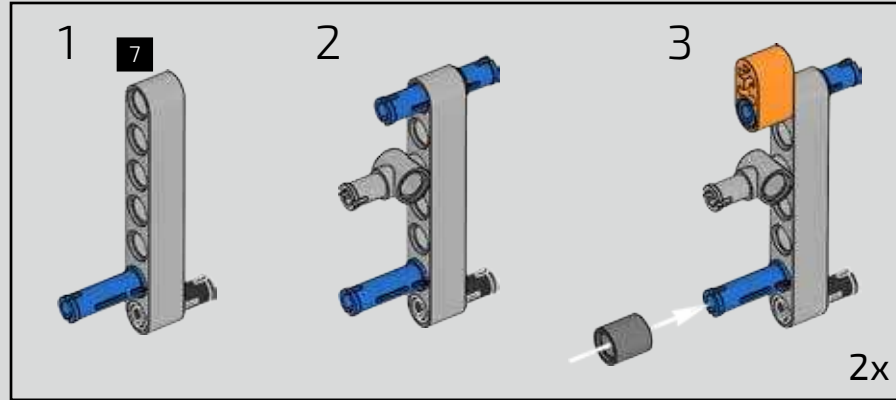

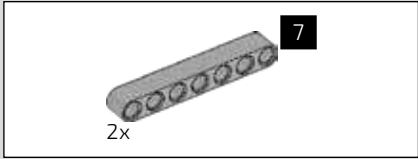

244

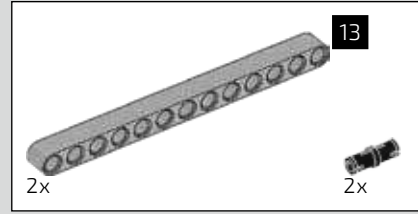
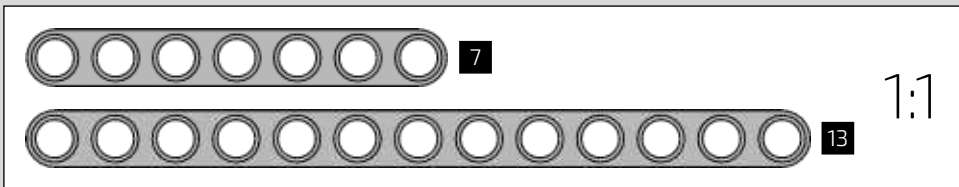
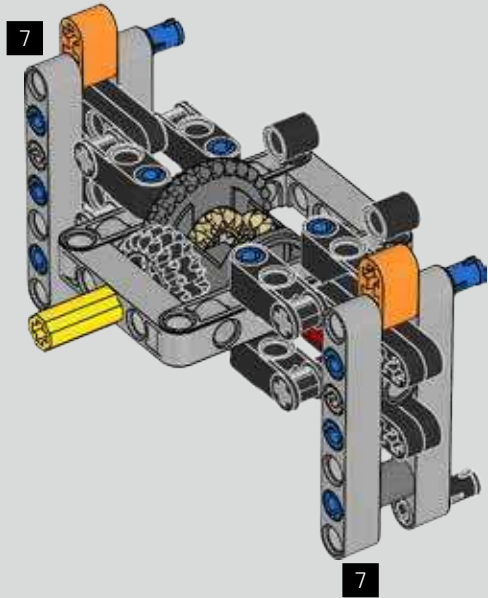

245

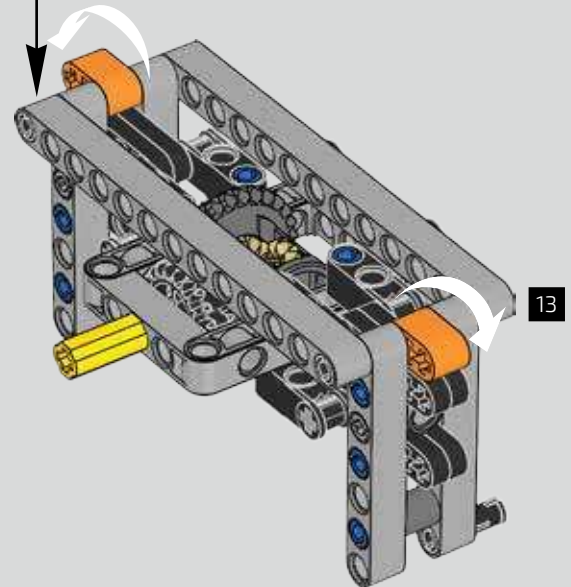
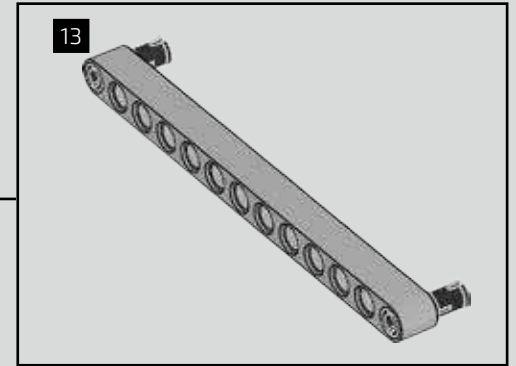

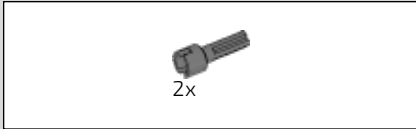

246

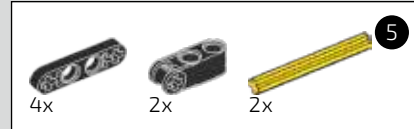
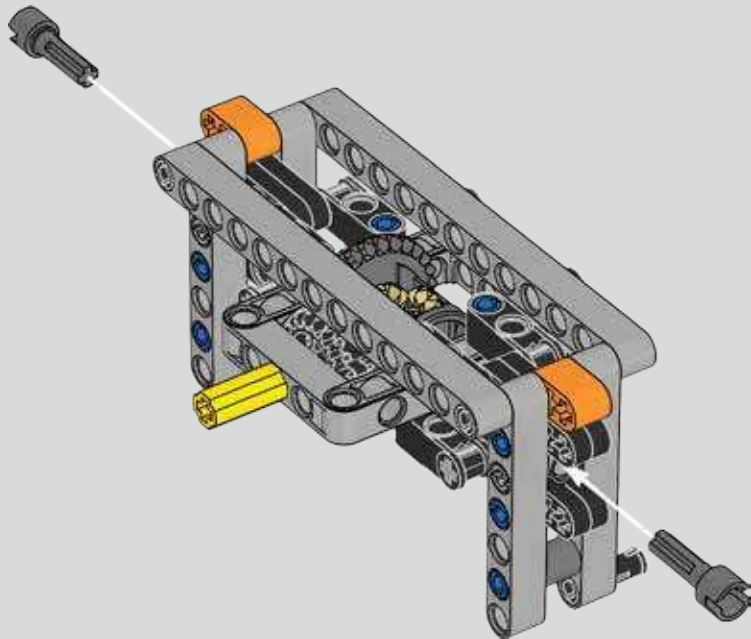

247

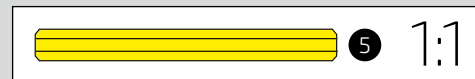
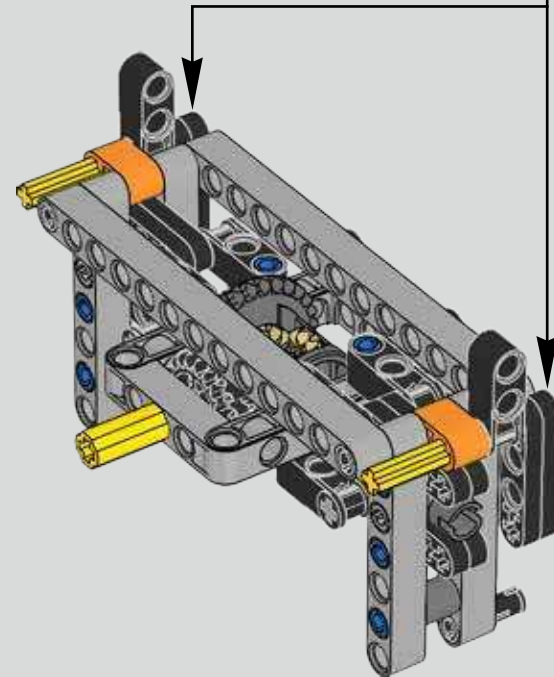
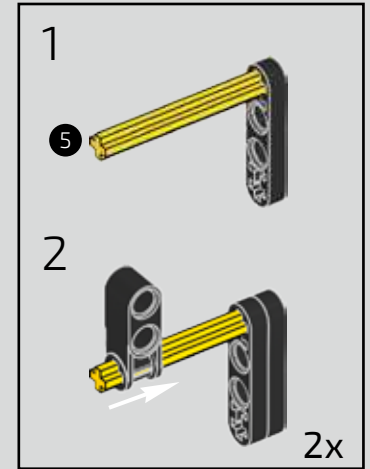

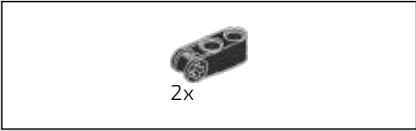

248

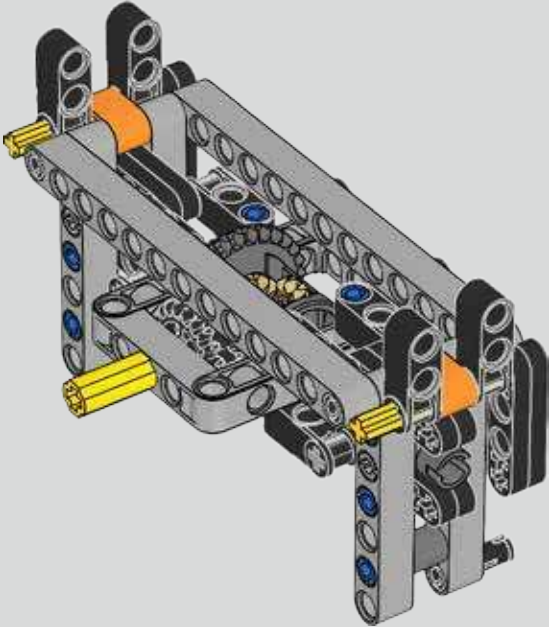

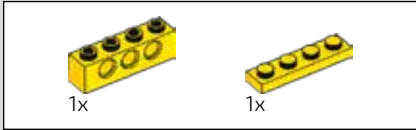
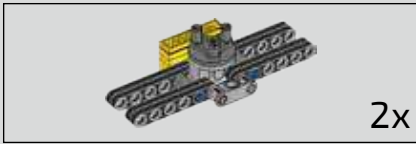

249

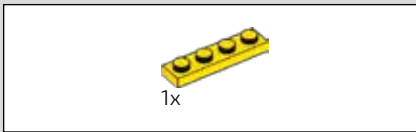
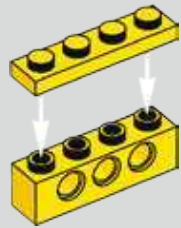

250

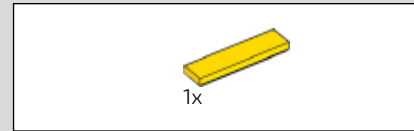
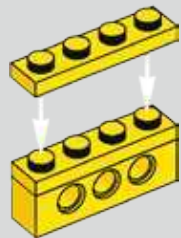

251

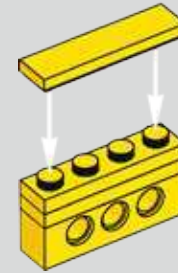

252

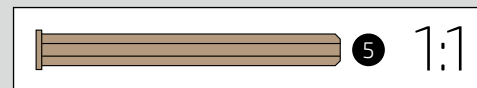
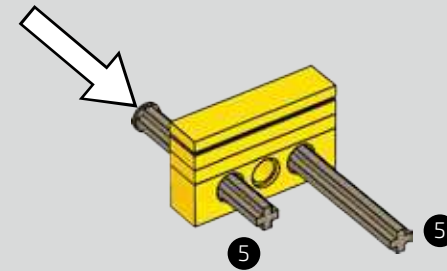

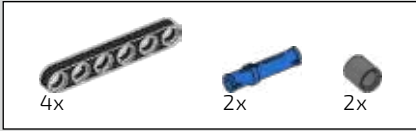

253

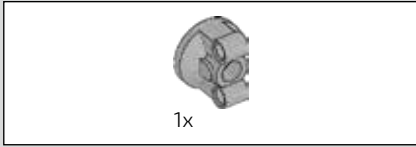
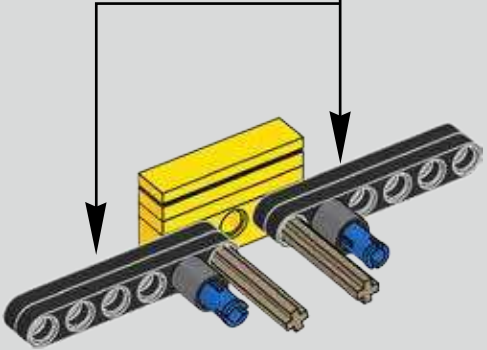
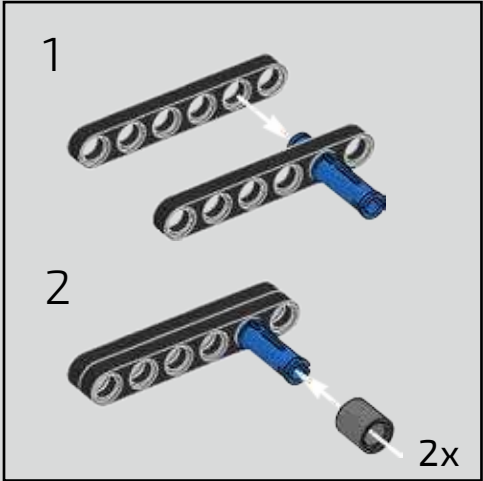

254

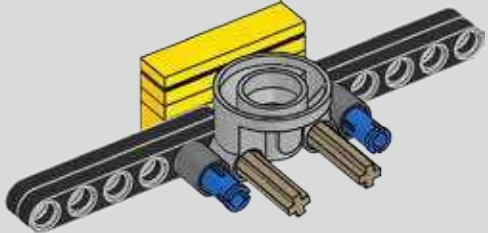

255

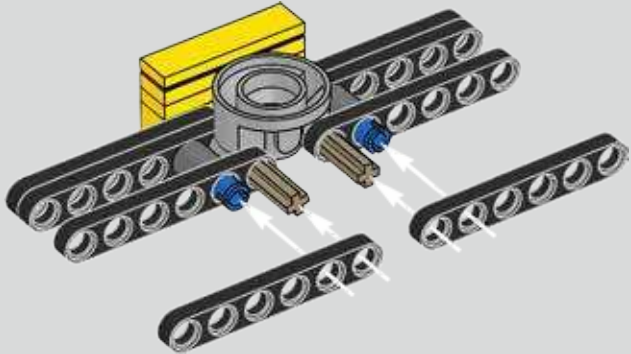

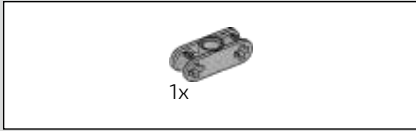

256

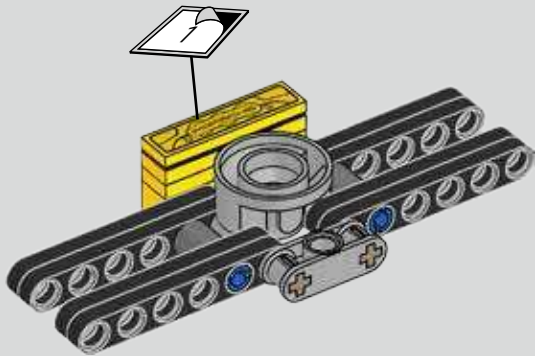

257

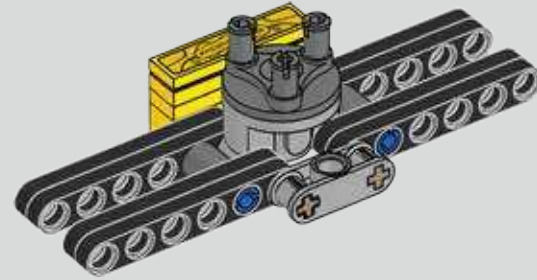

258

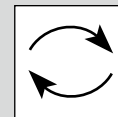

2x

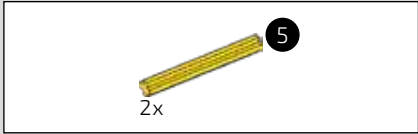

259

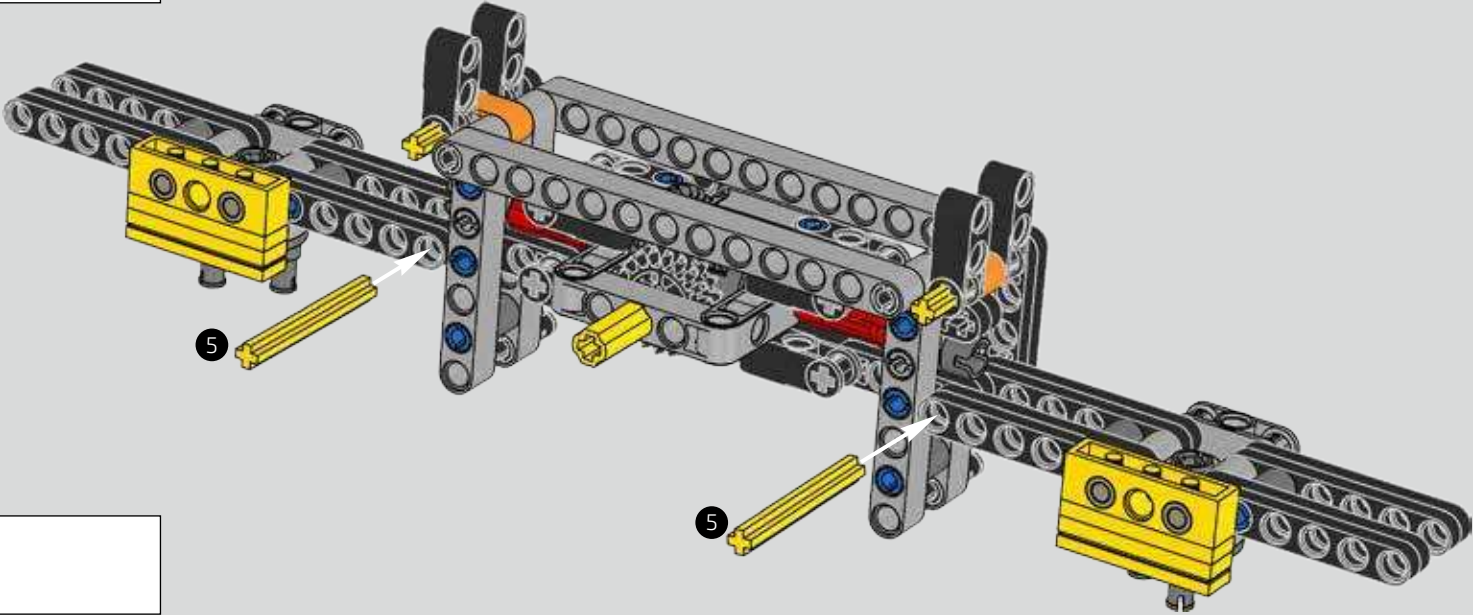

260

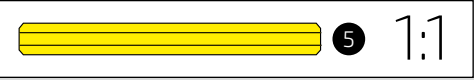
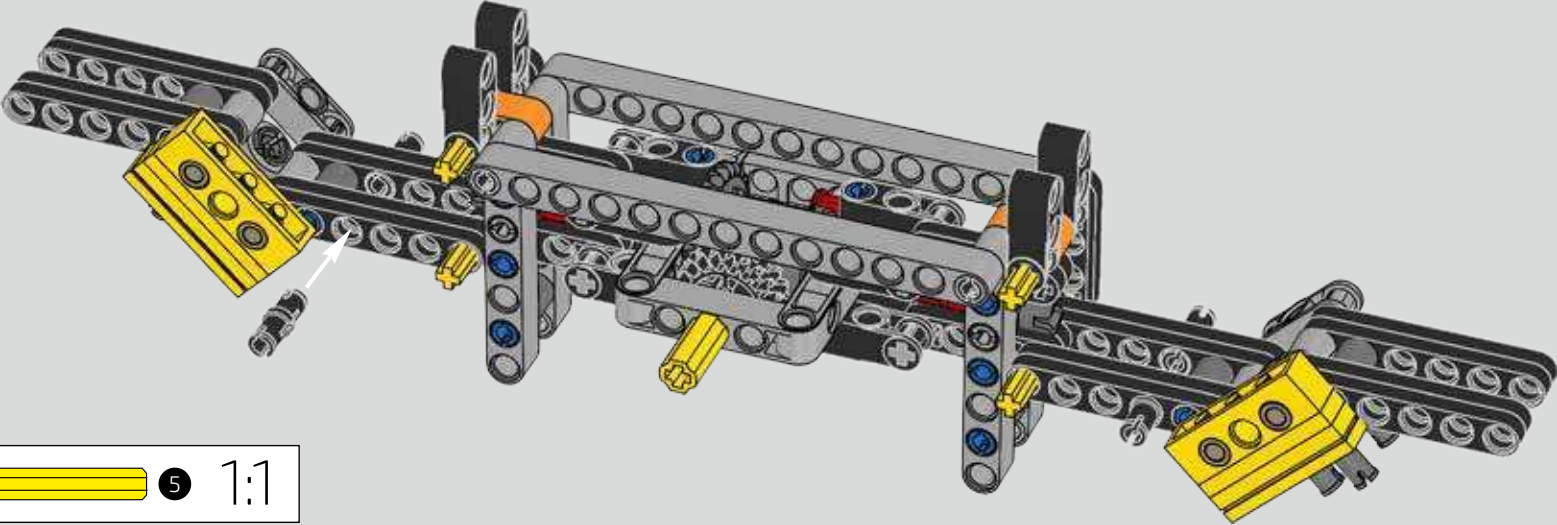

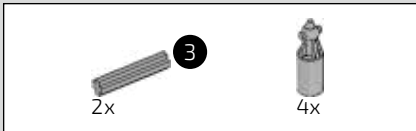

261

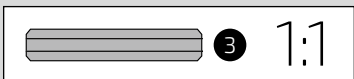
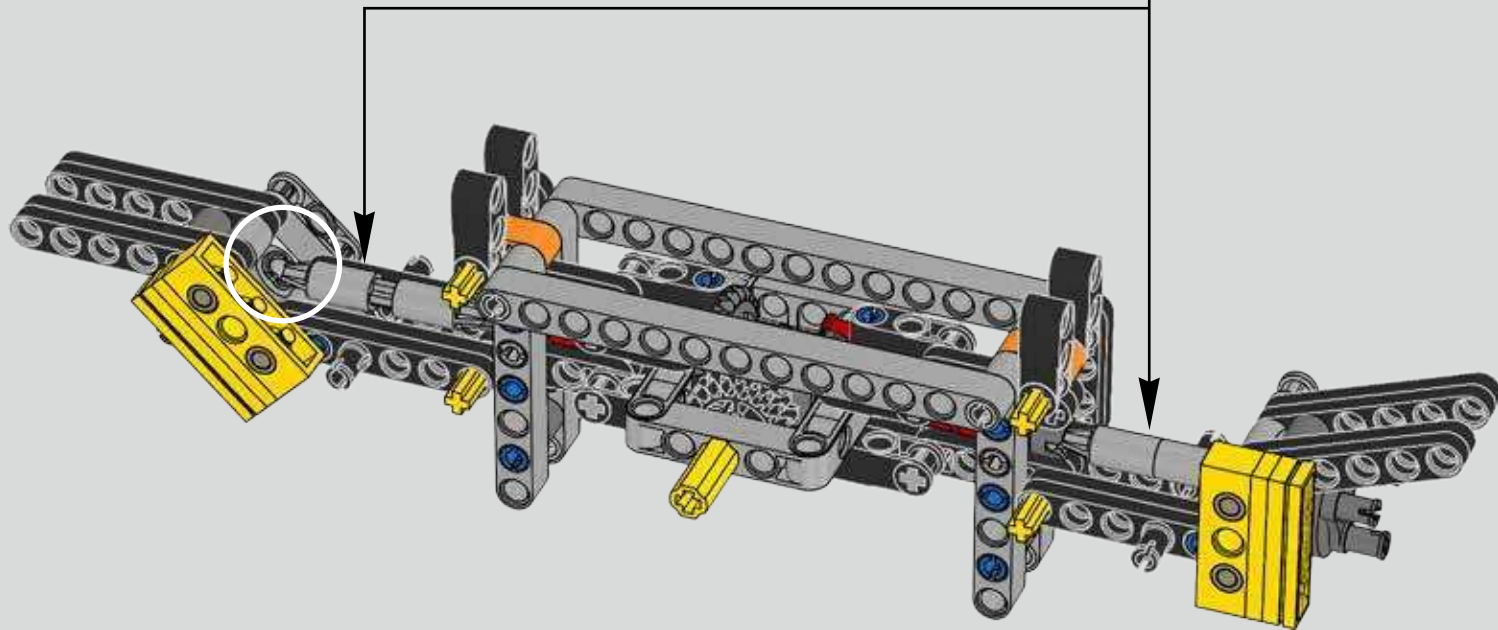
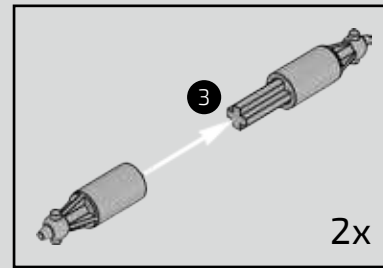

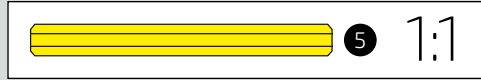
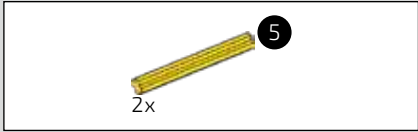

262

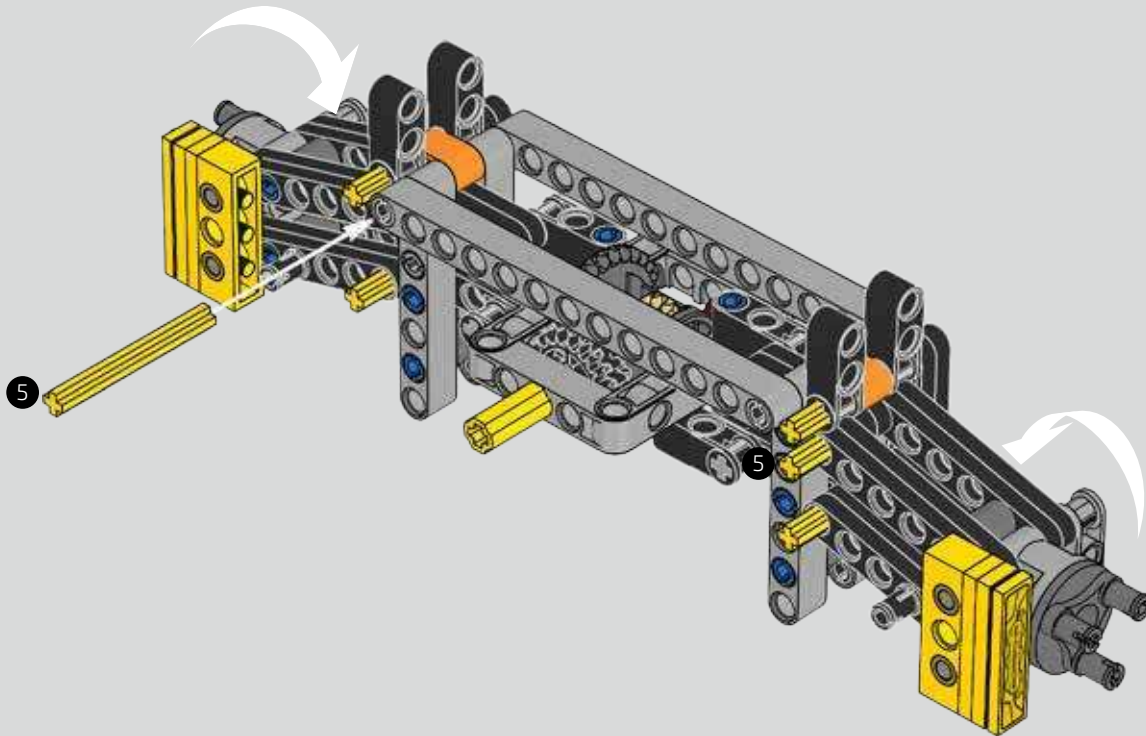

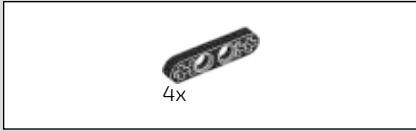

263

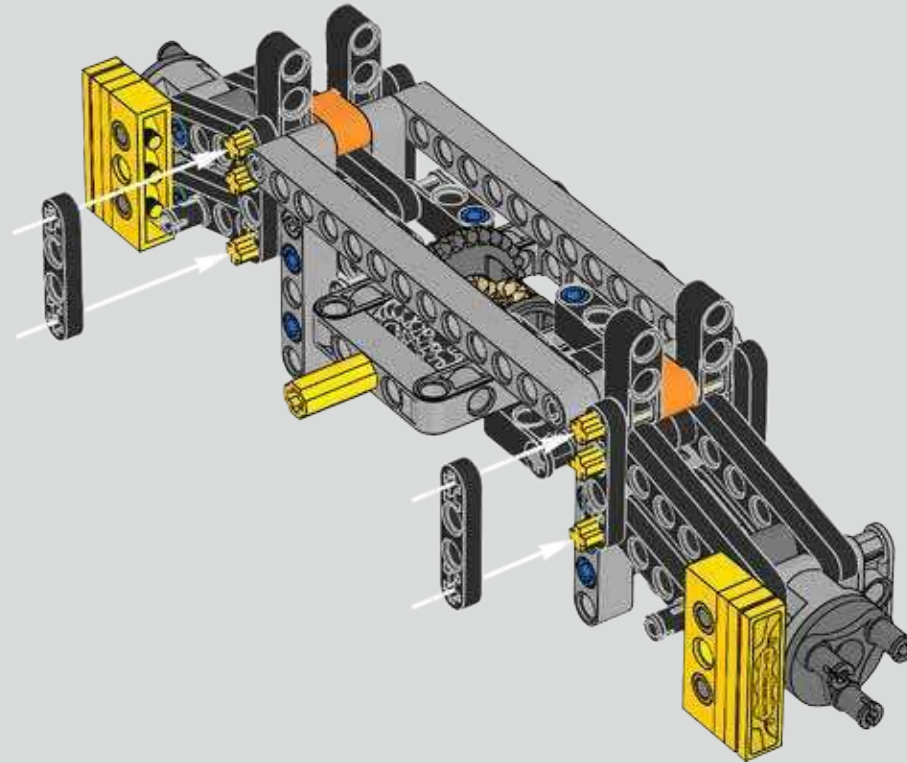

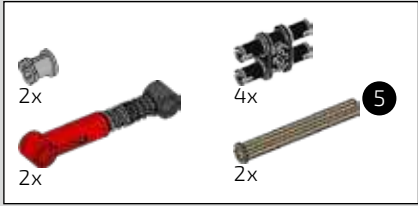

264

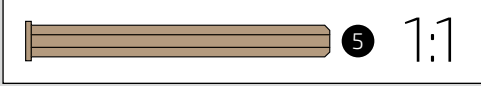
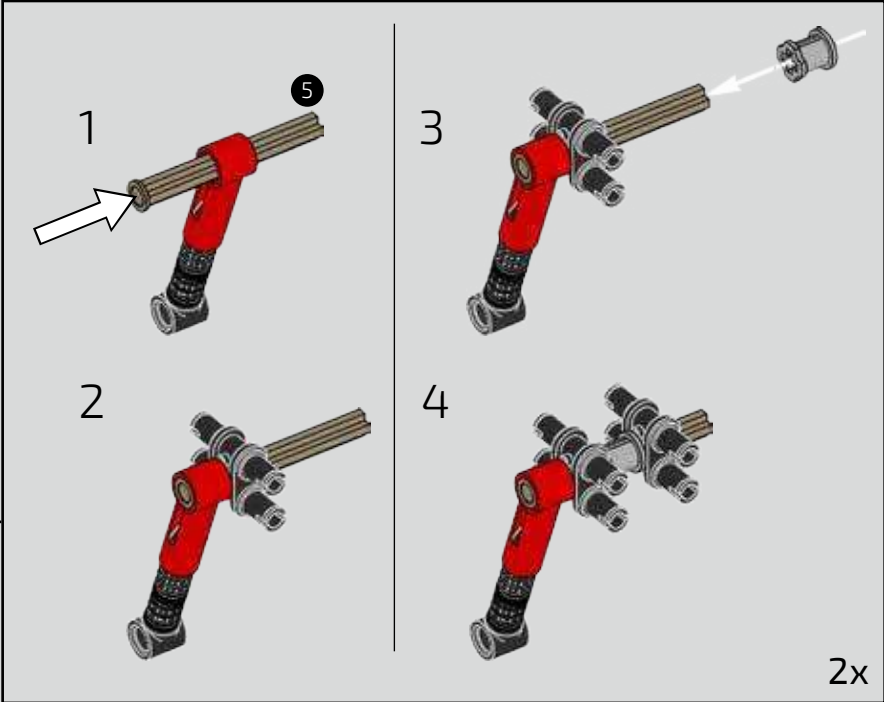
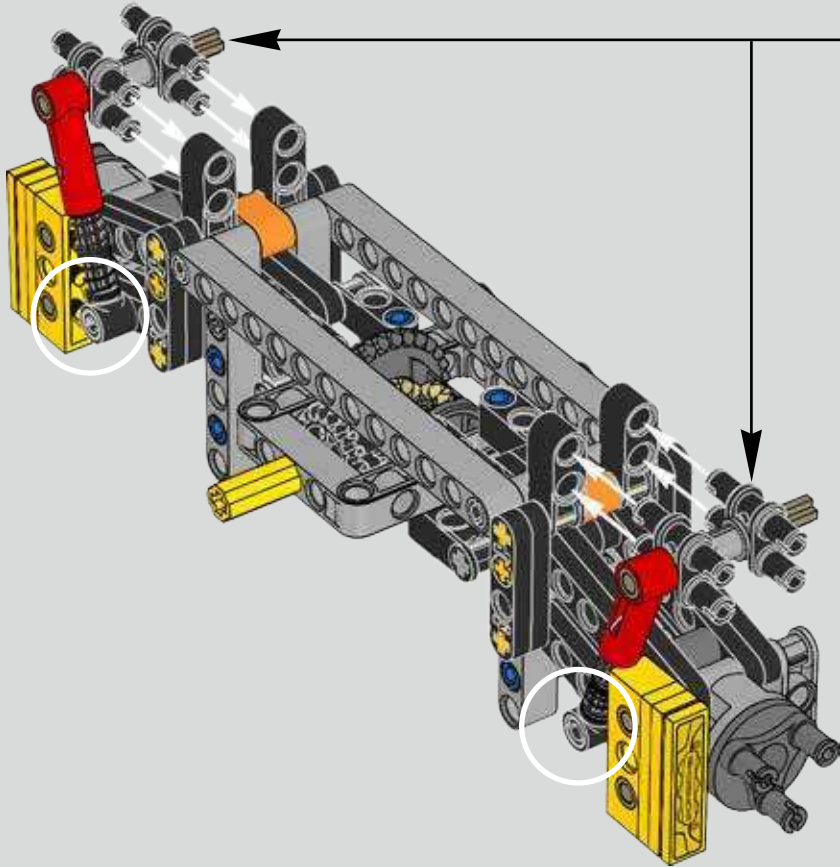

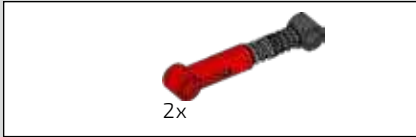

265

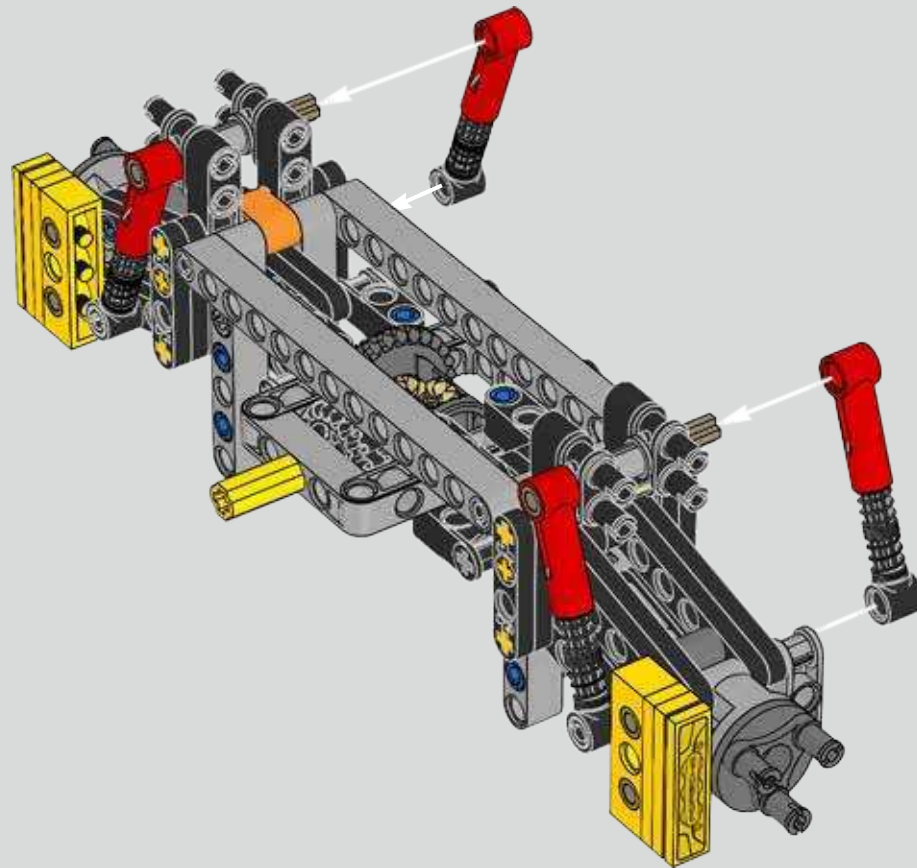

266

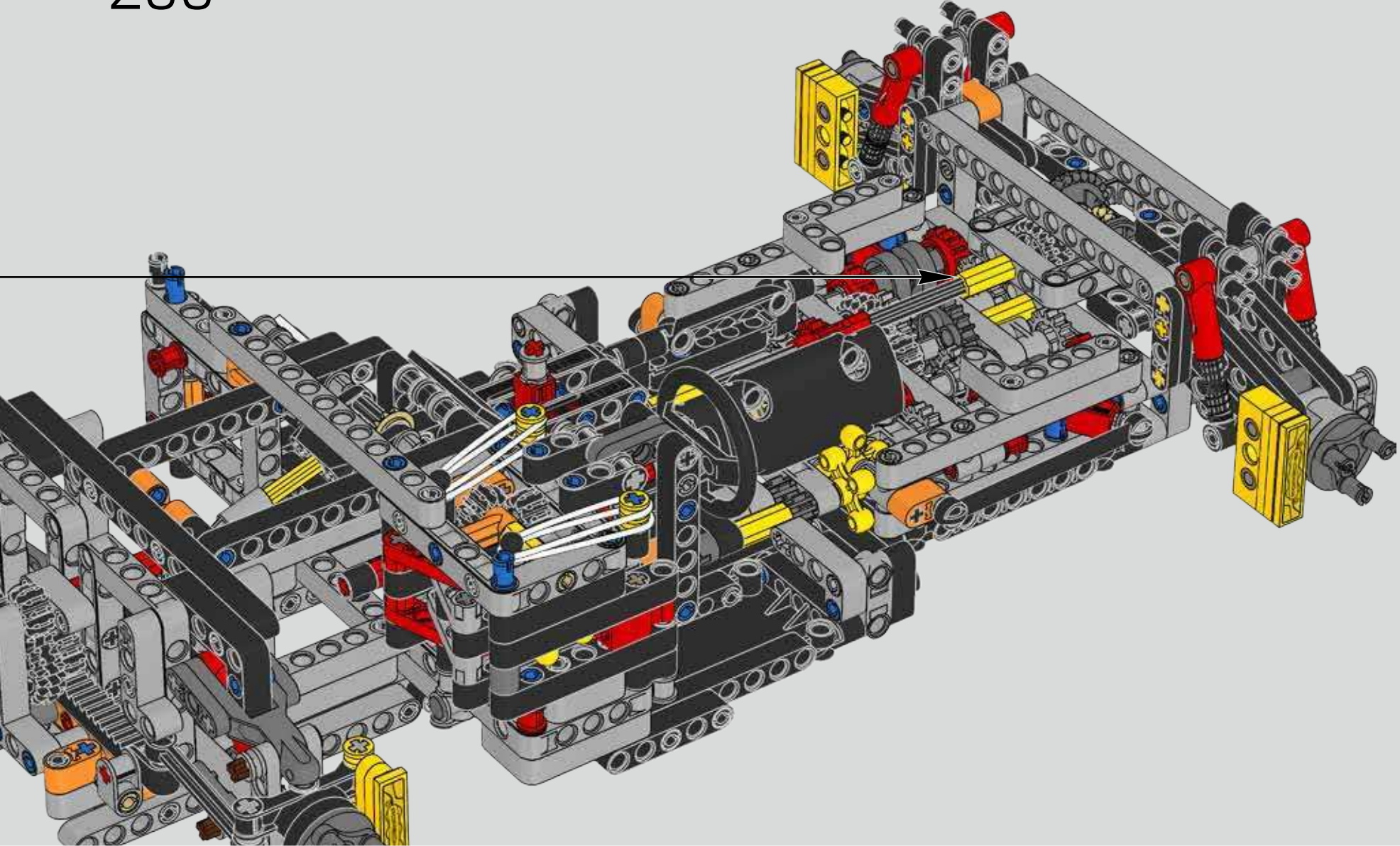

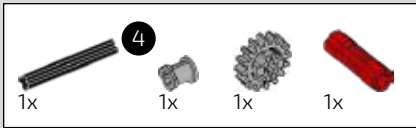

267

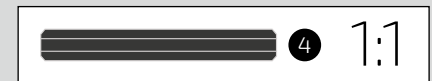
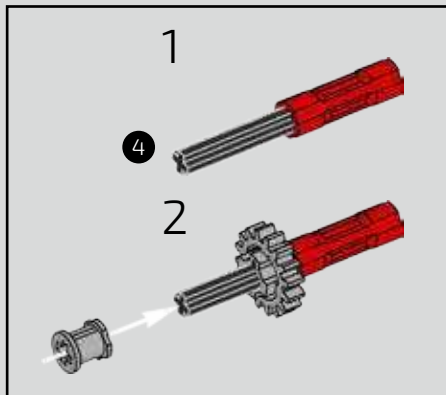
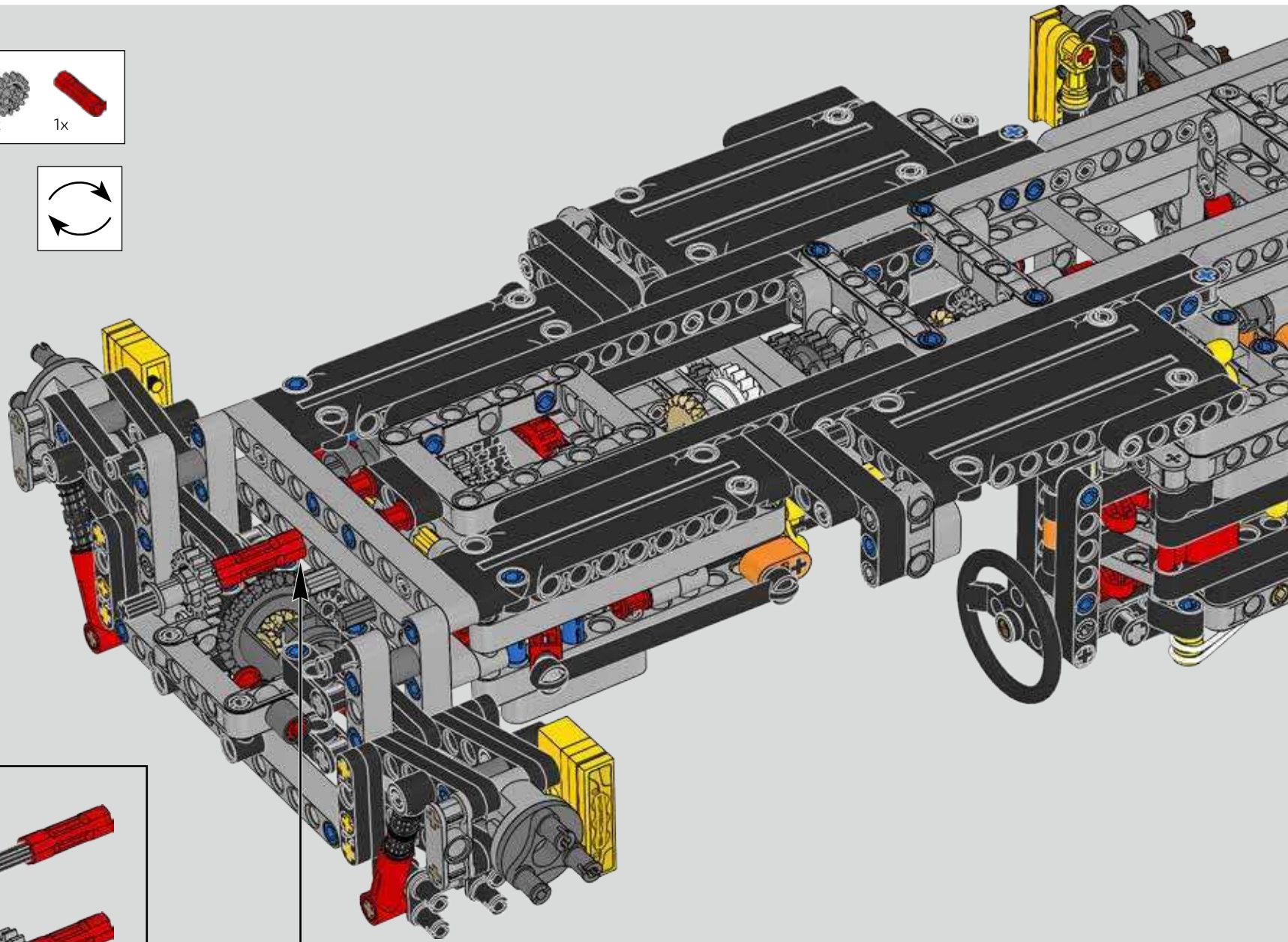
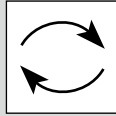

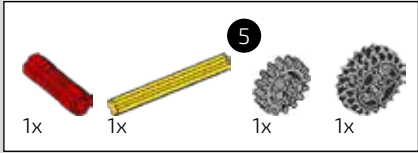

268

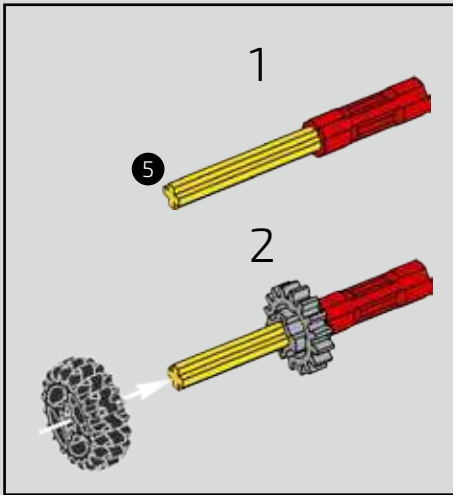
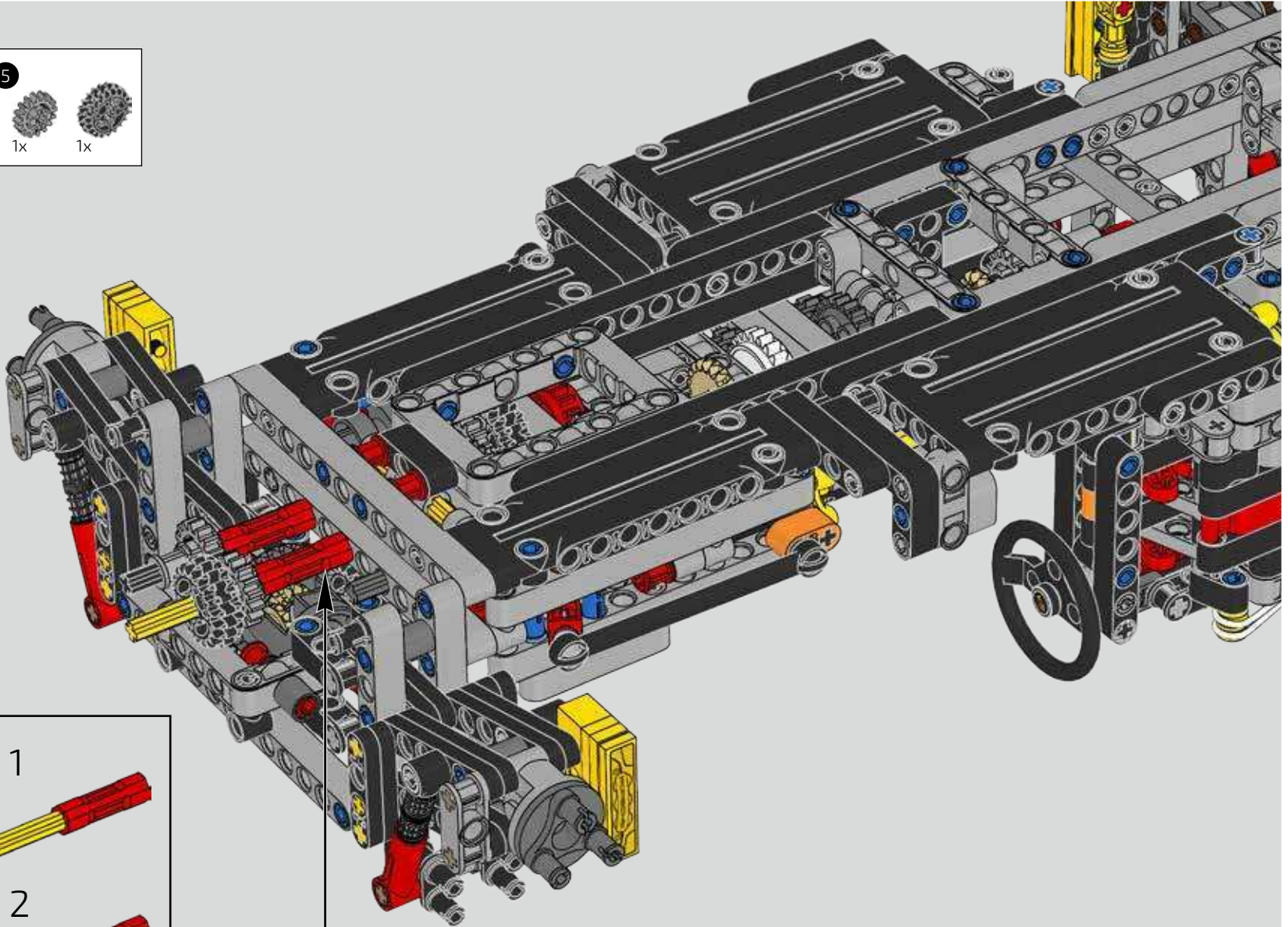

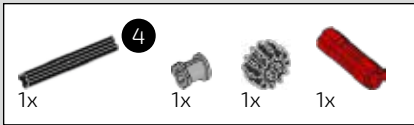

269

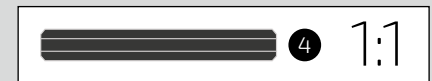
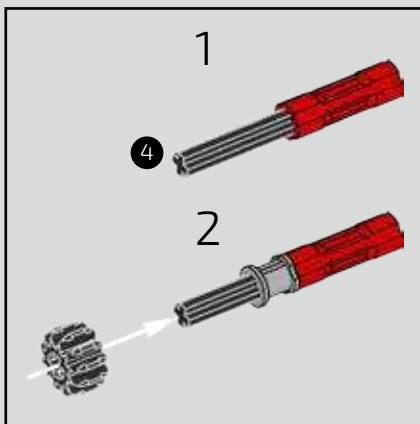
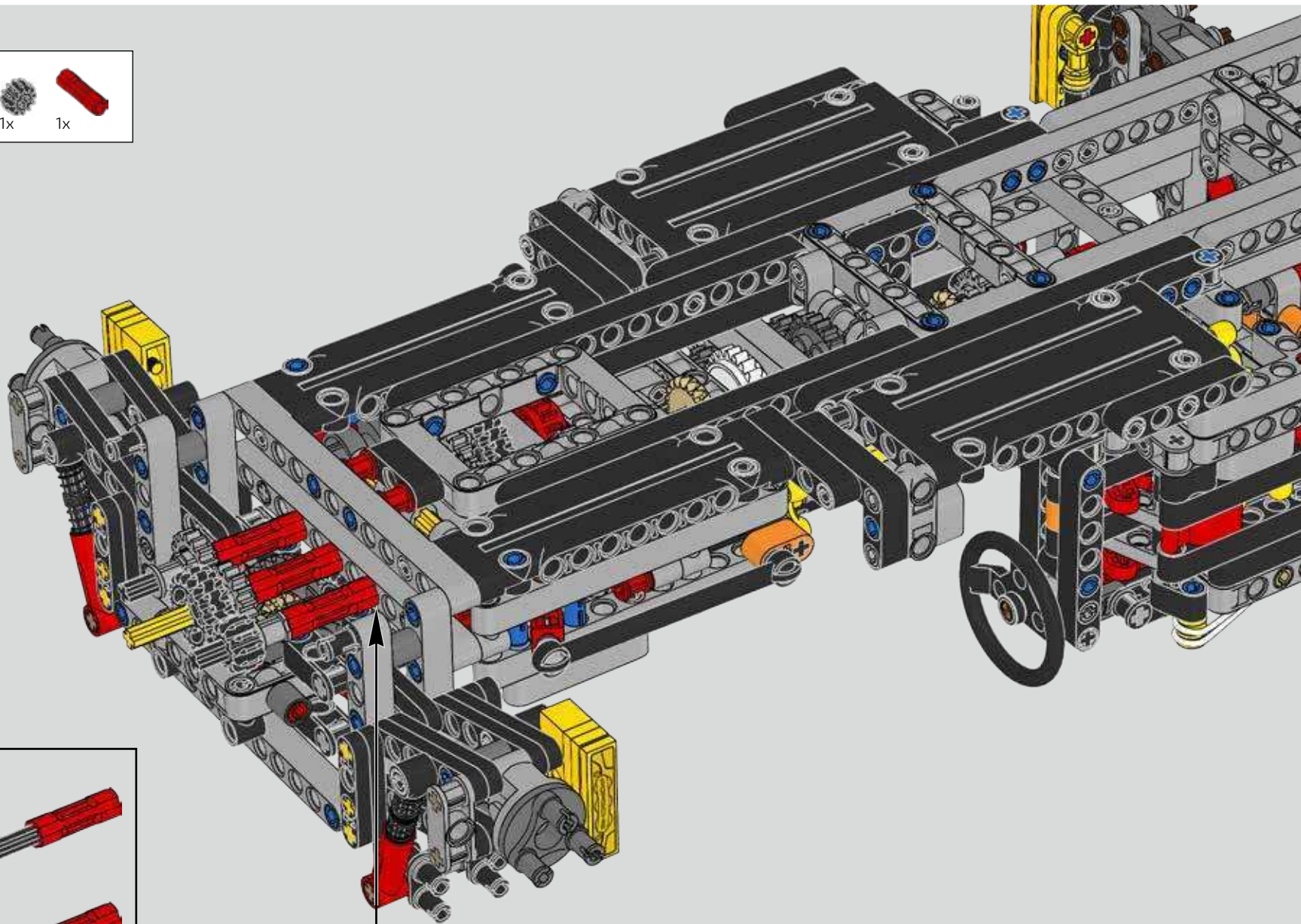

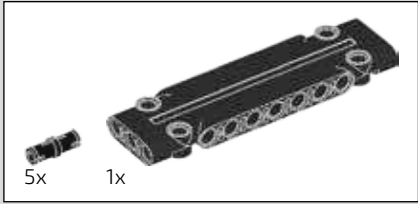

270

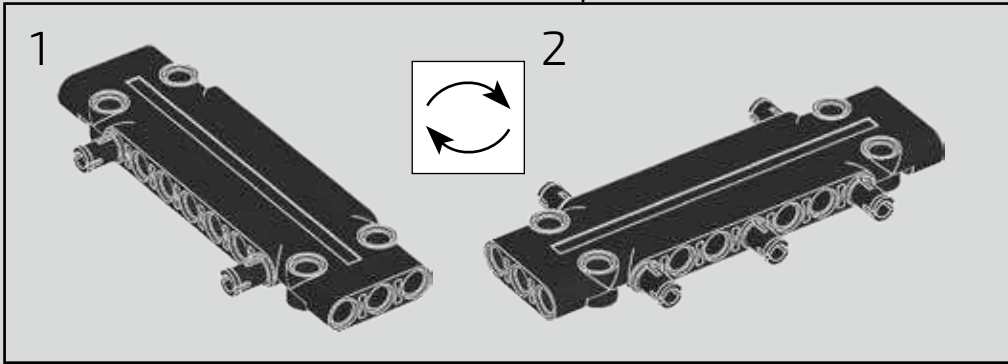
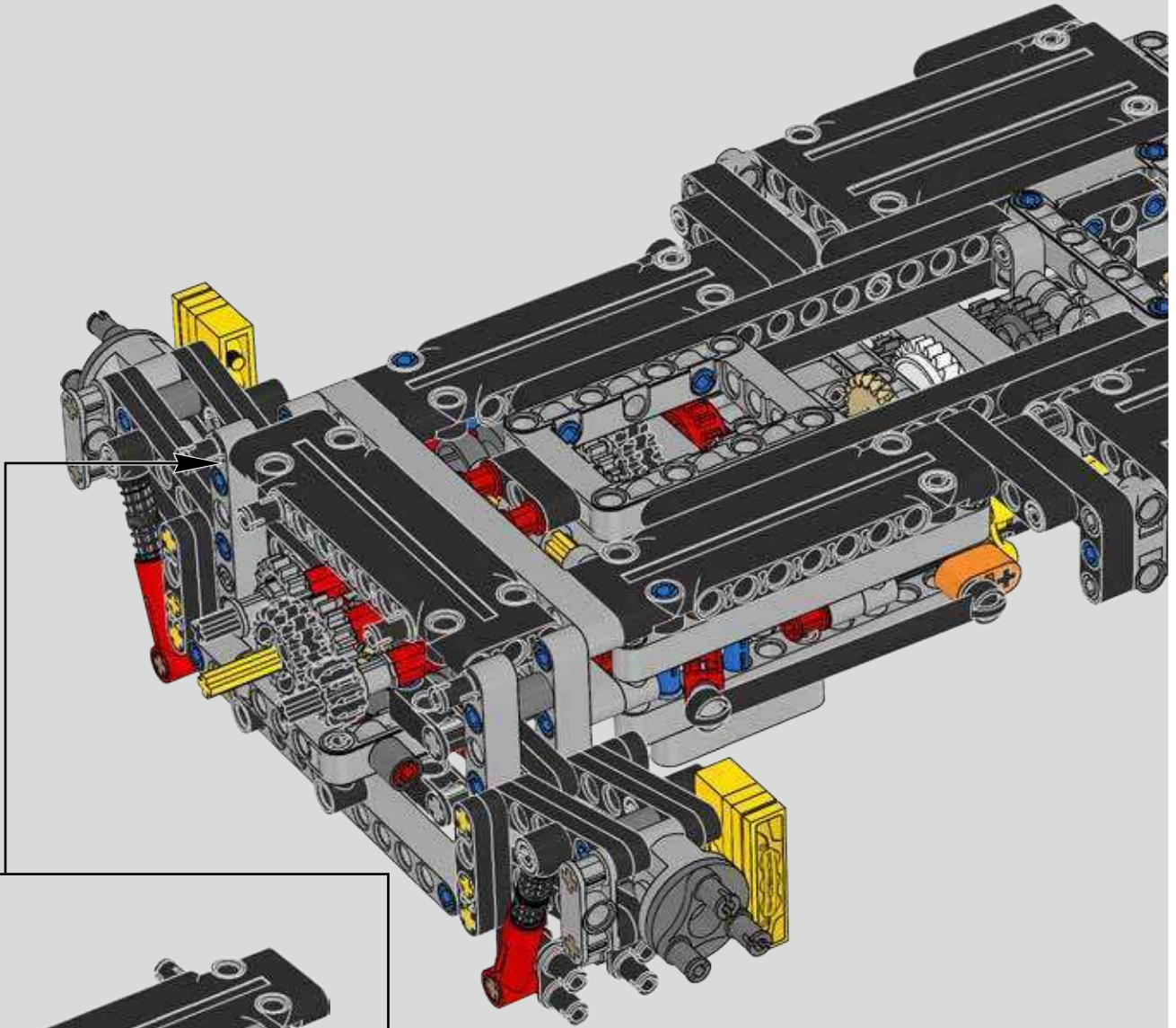

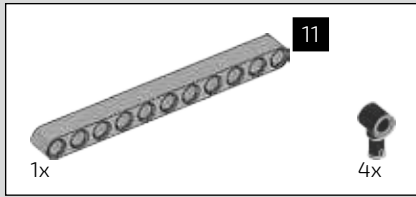

271

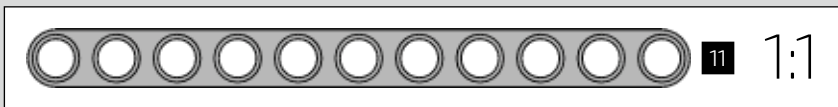
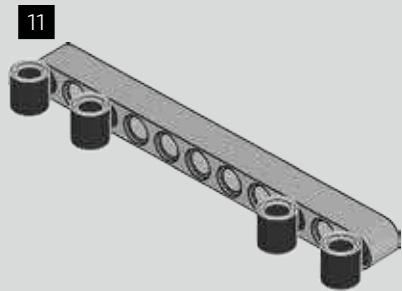

272

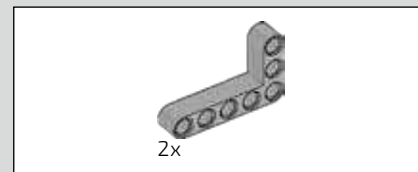
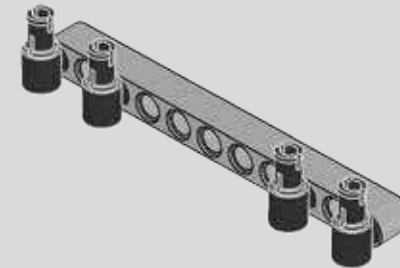

273

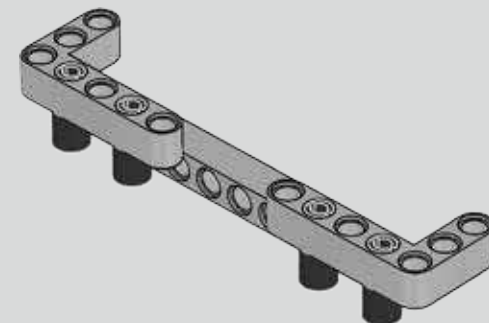

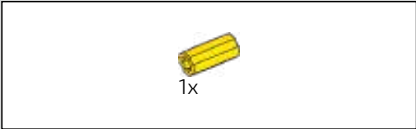

274

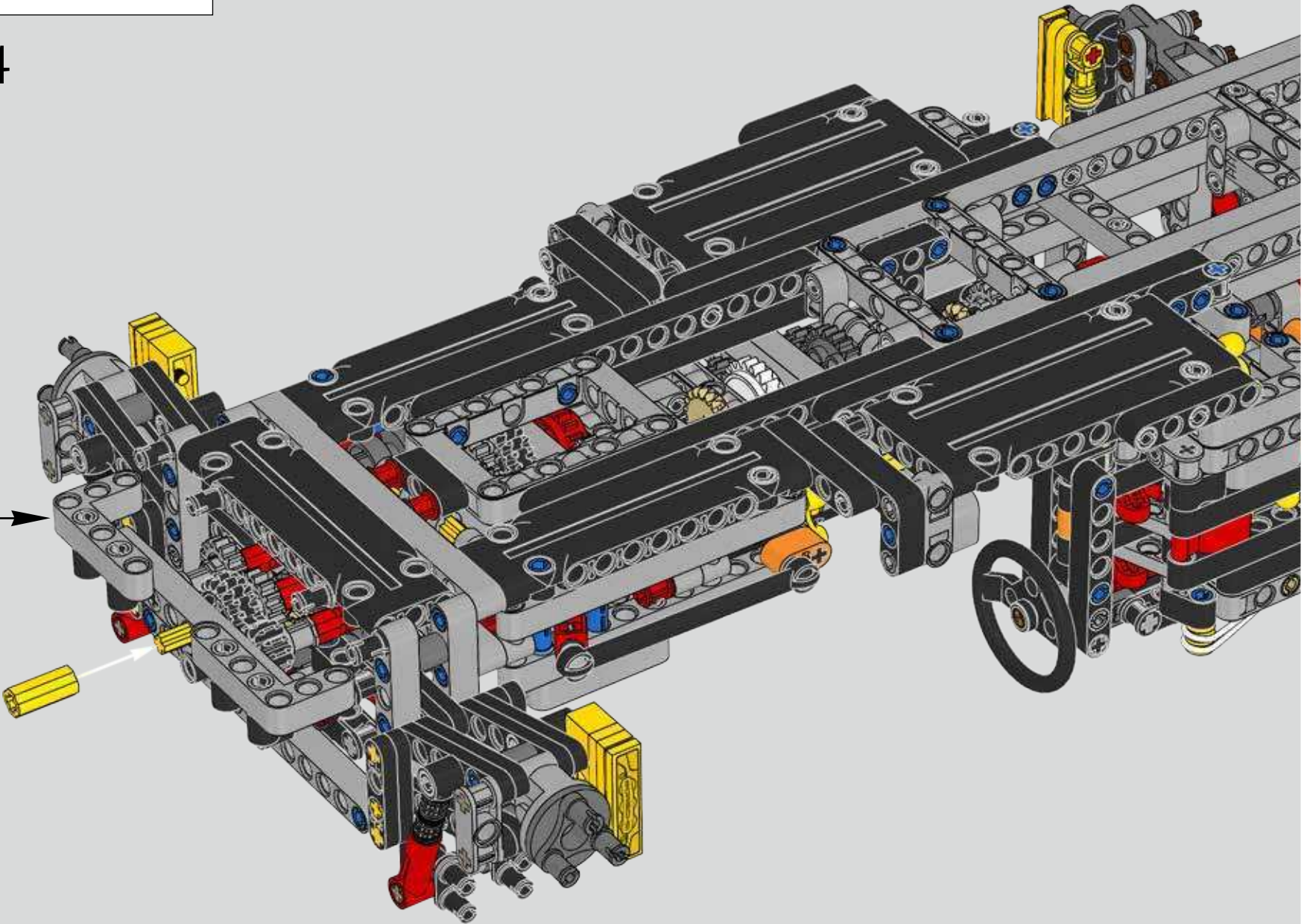

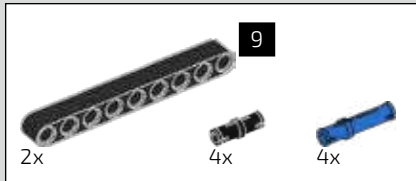

275

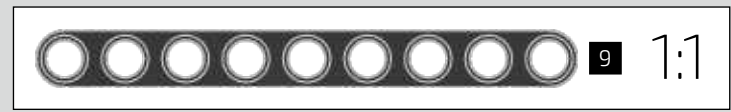
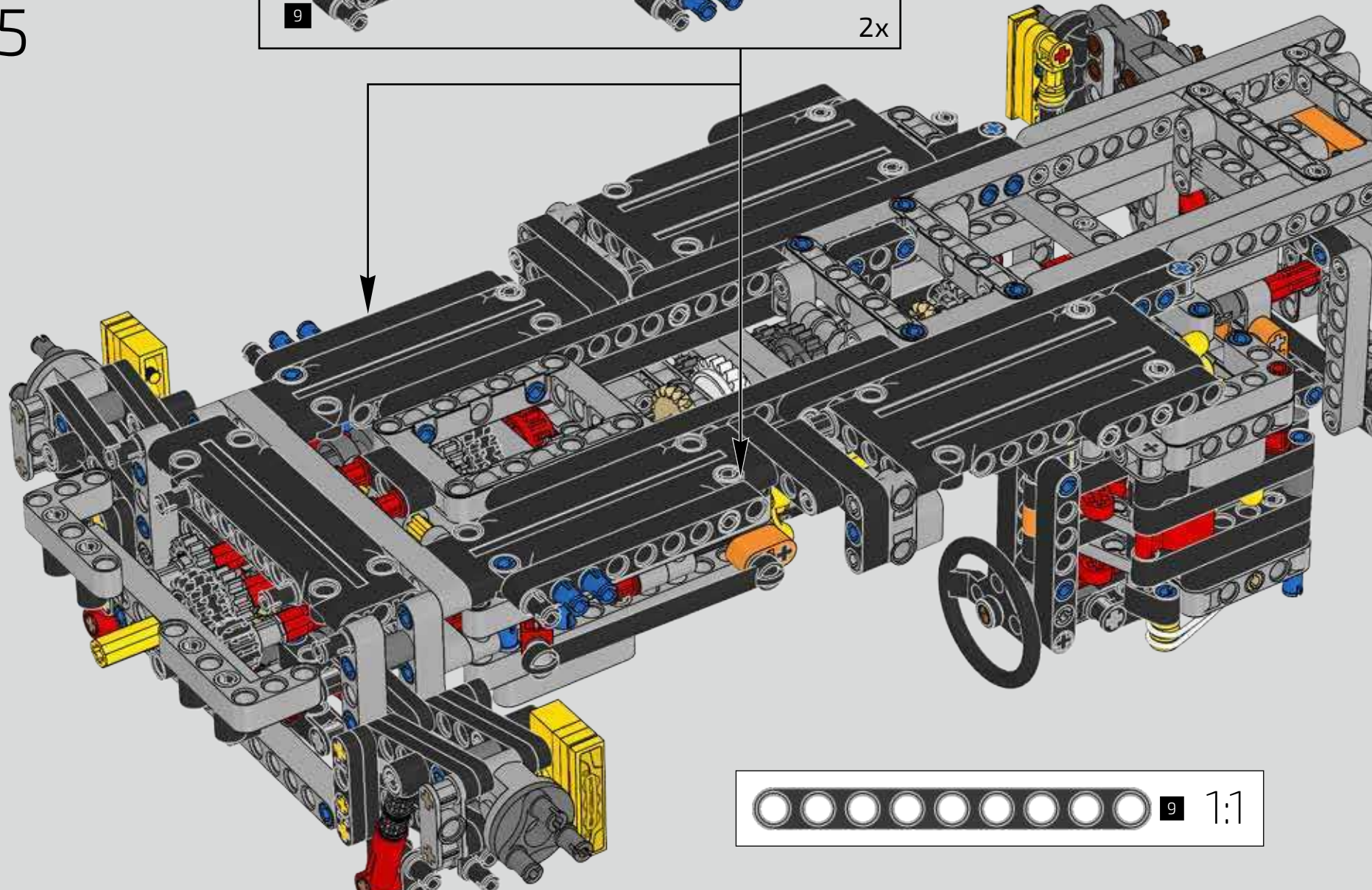
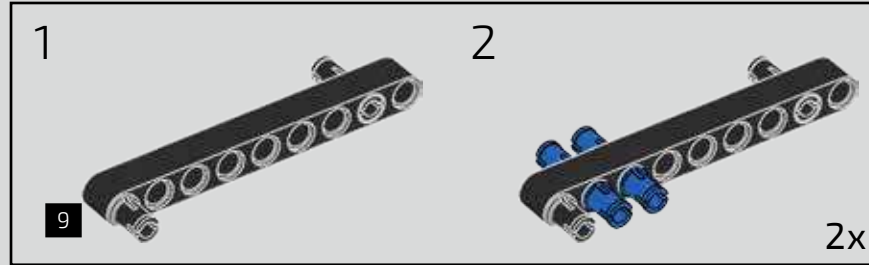

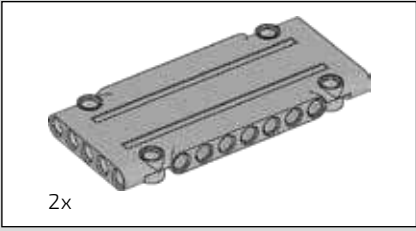

276

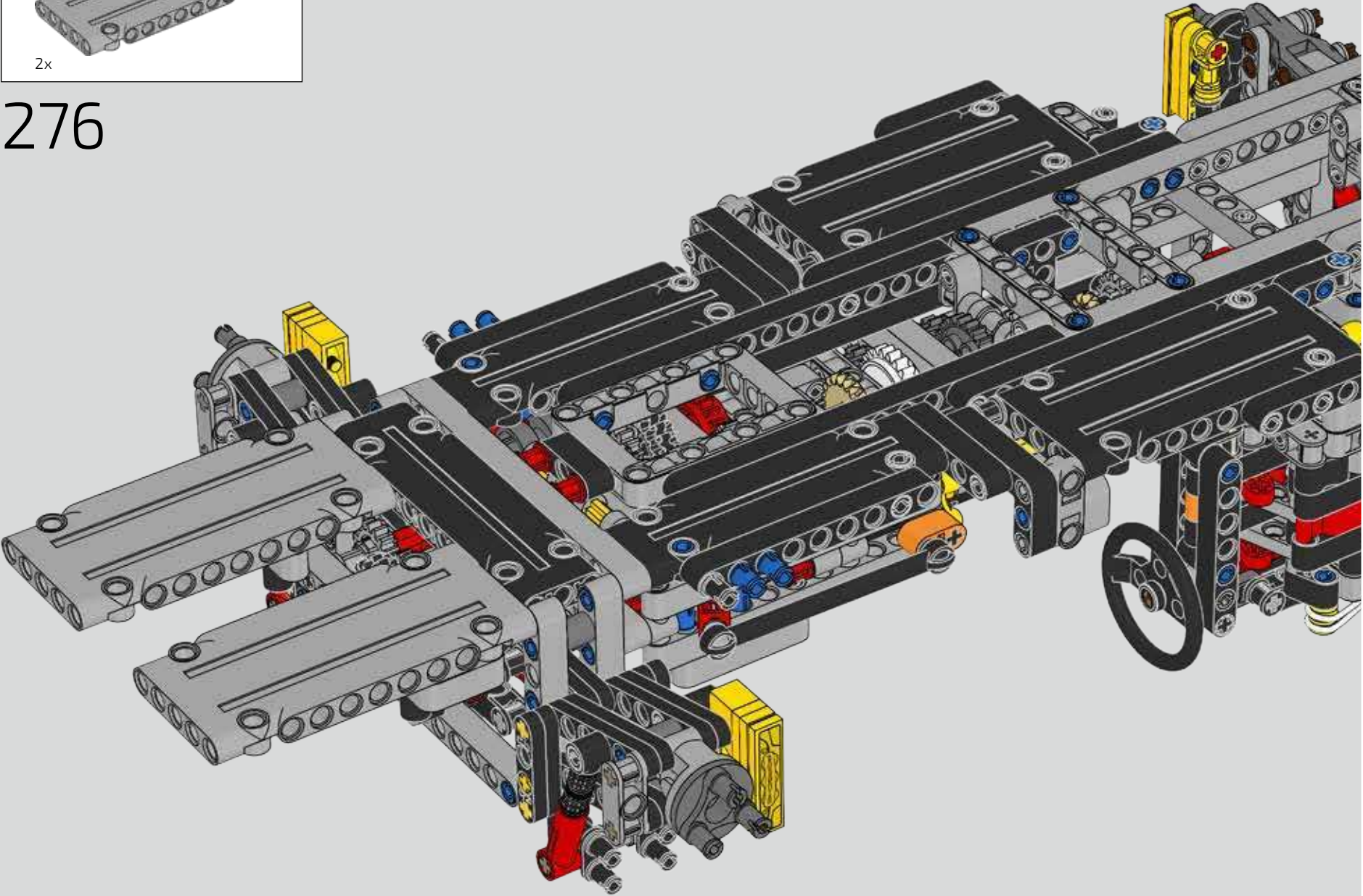

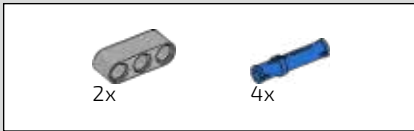

277

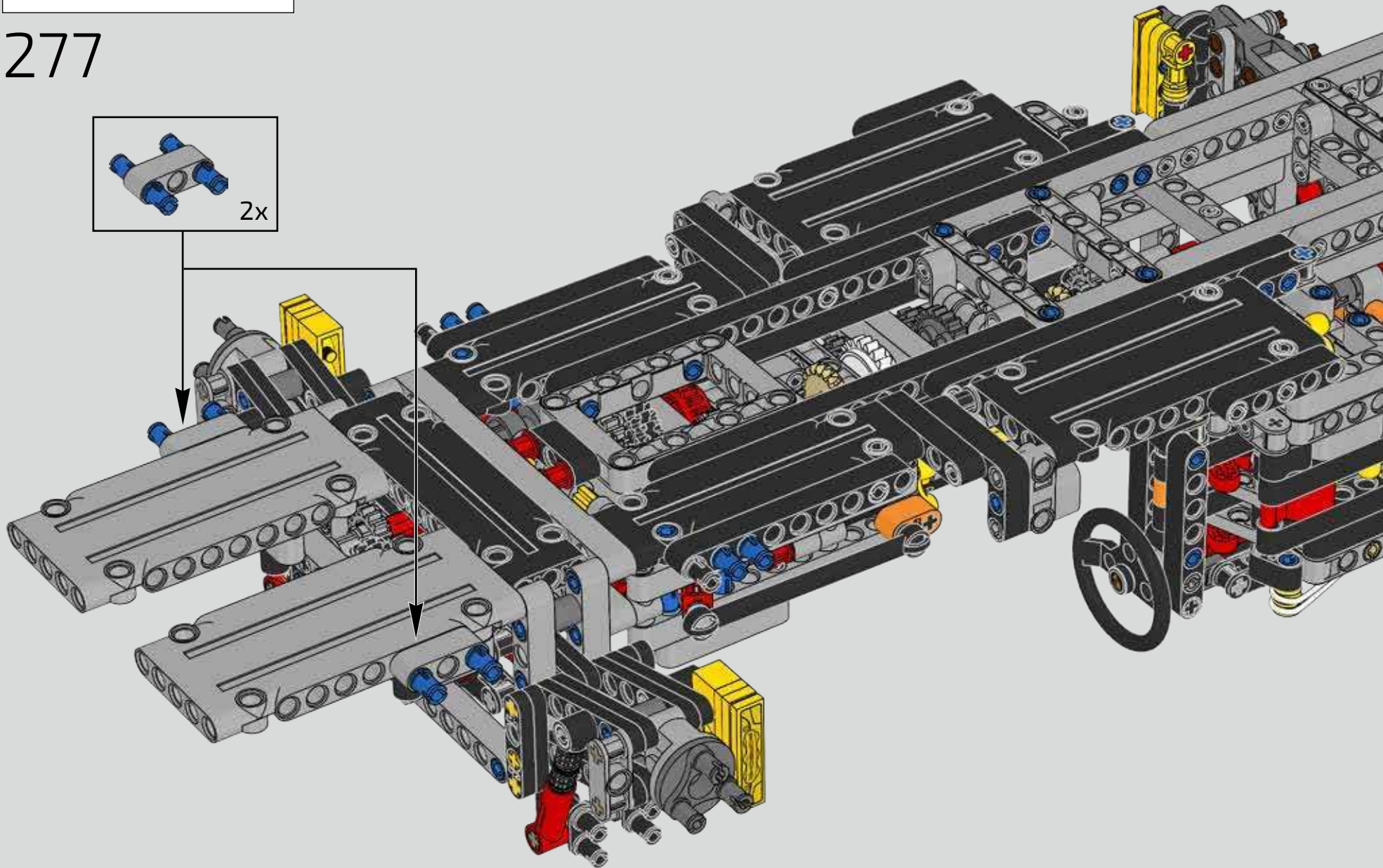
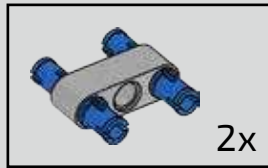



278

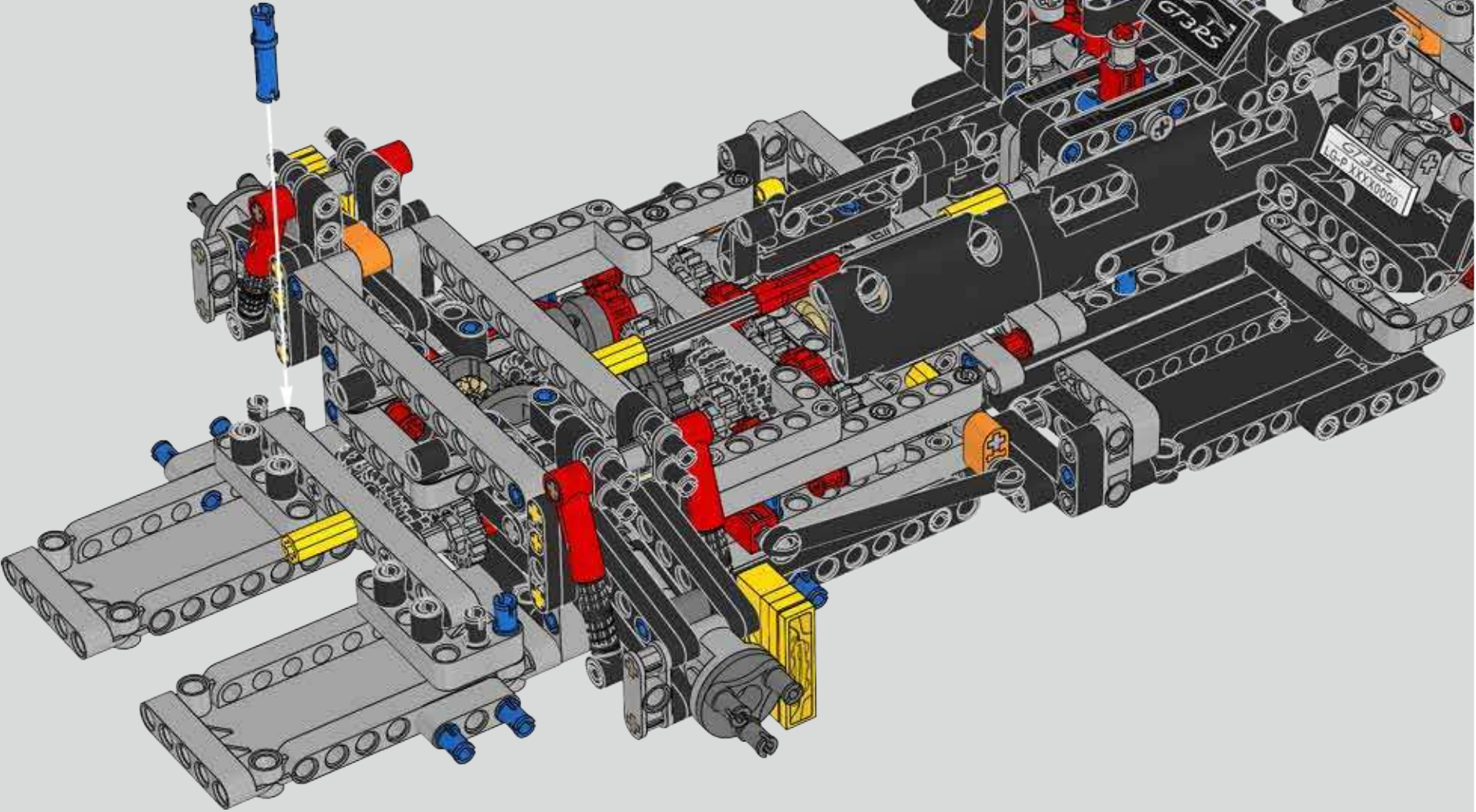
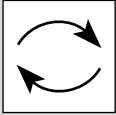

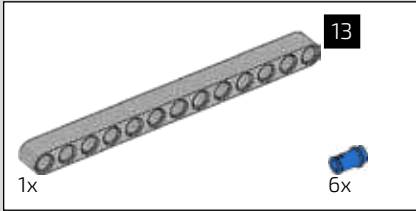
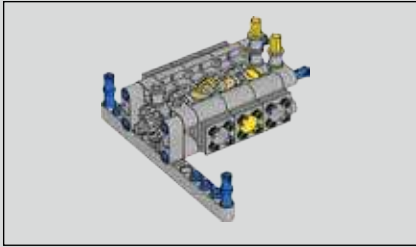

279

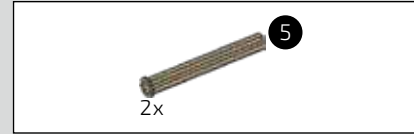
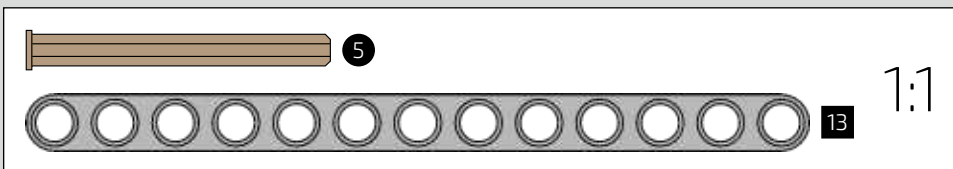
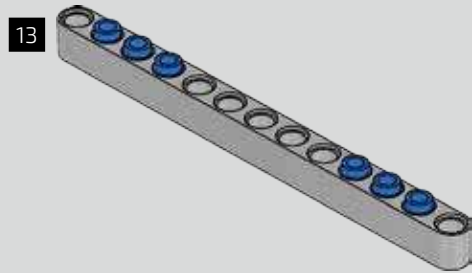

280

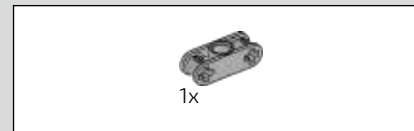
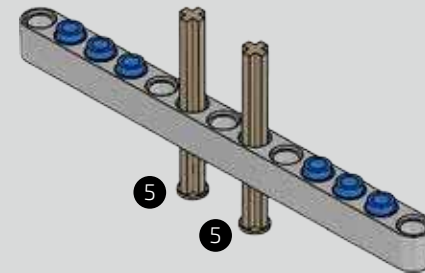

281

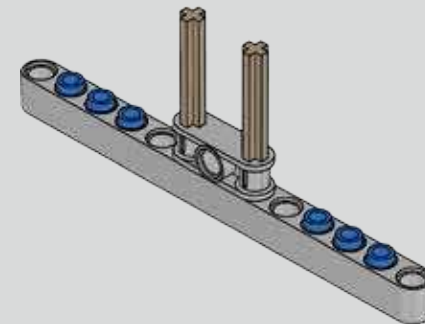

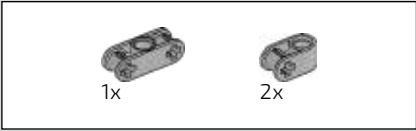

282

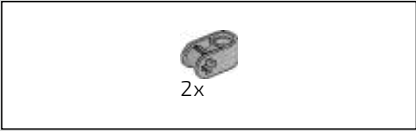
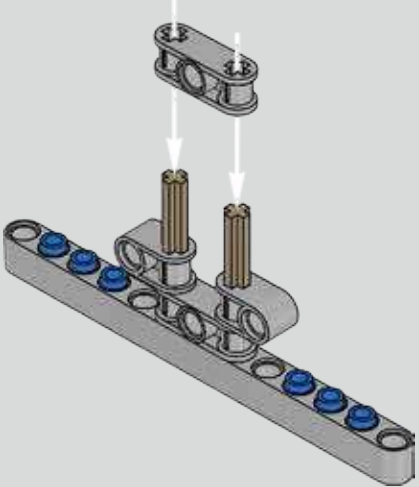

283

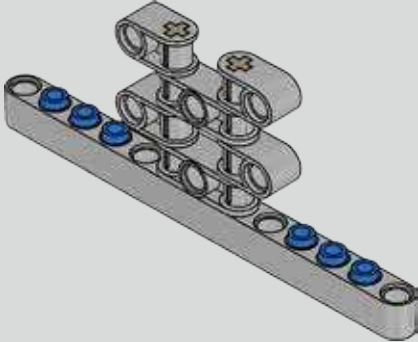

284

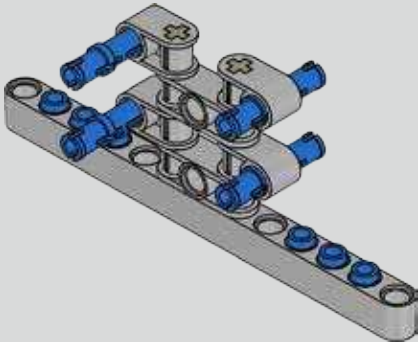

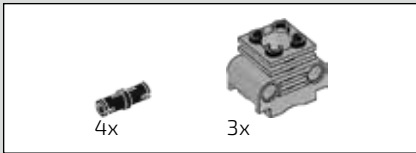

285

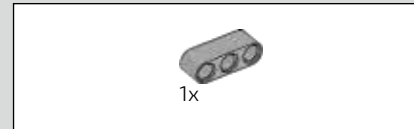
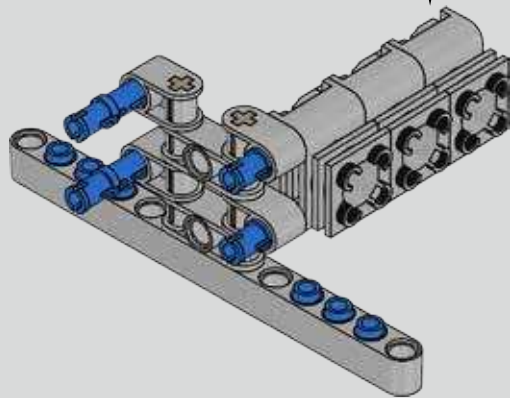
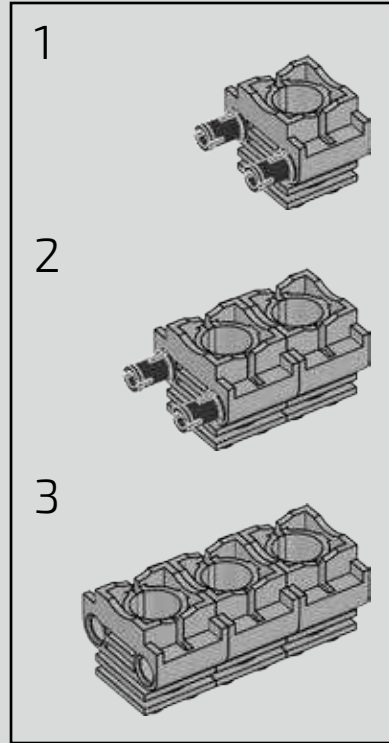

286

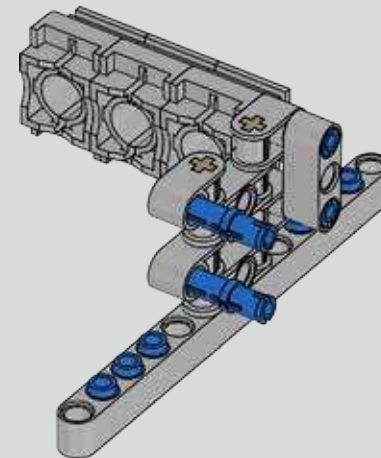
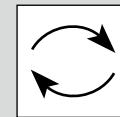

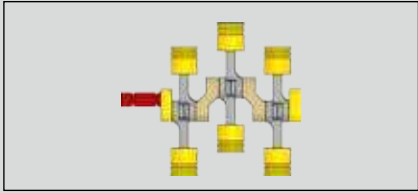

287

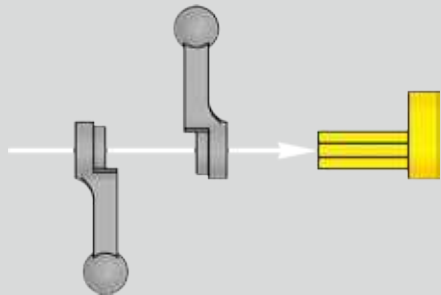

288

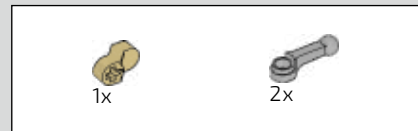
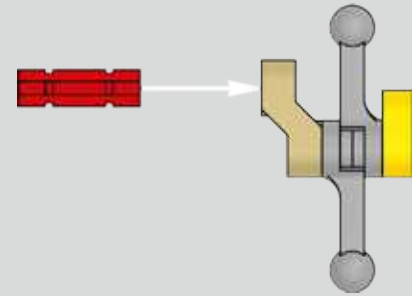

289

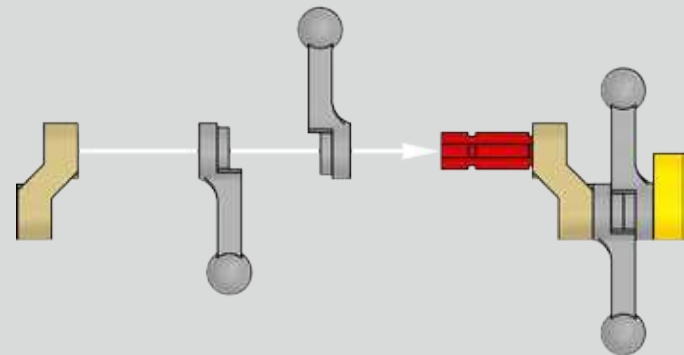

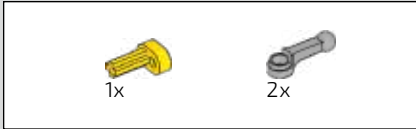

290

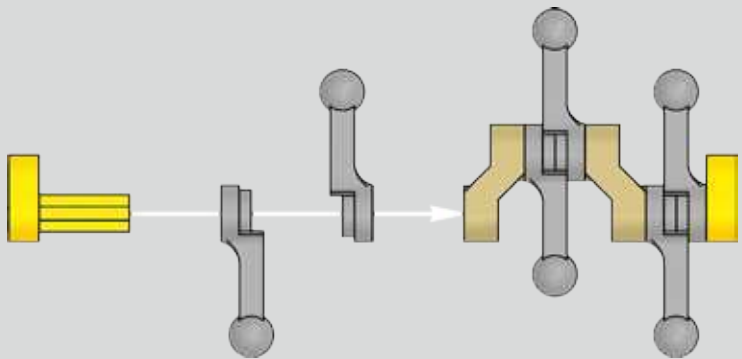

291

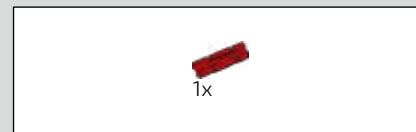
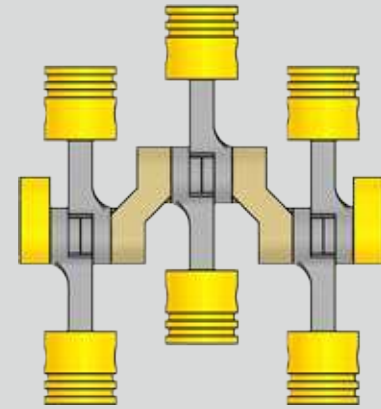

292

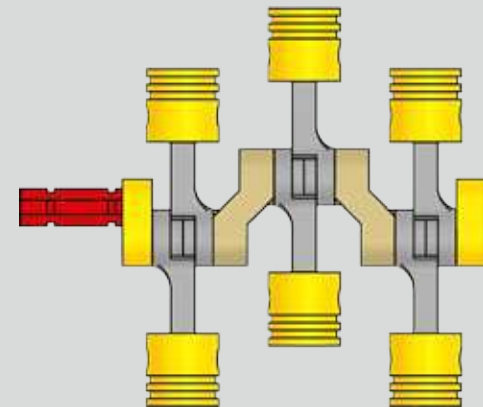

1:1

293

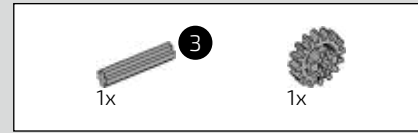
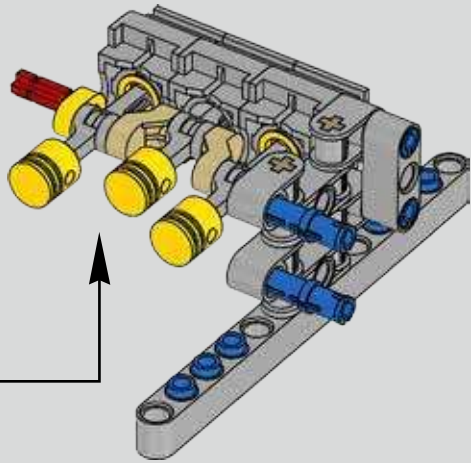

294

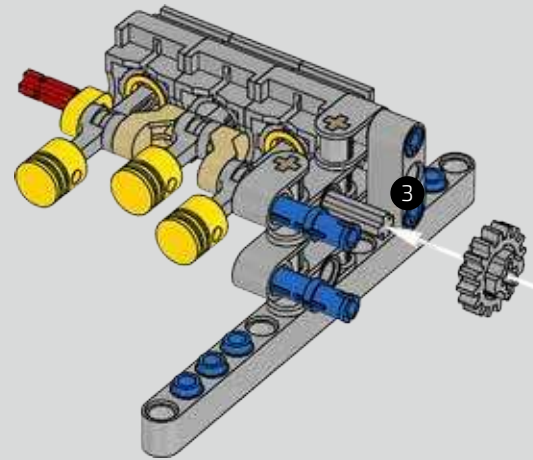

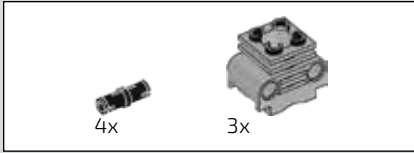

295

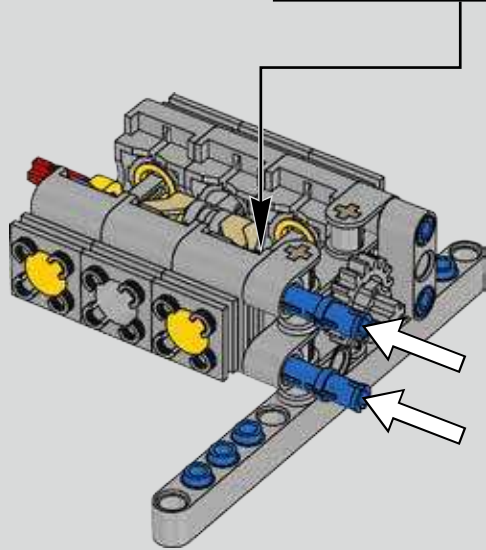
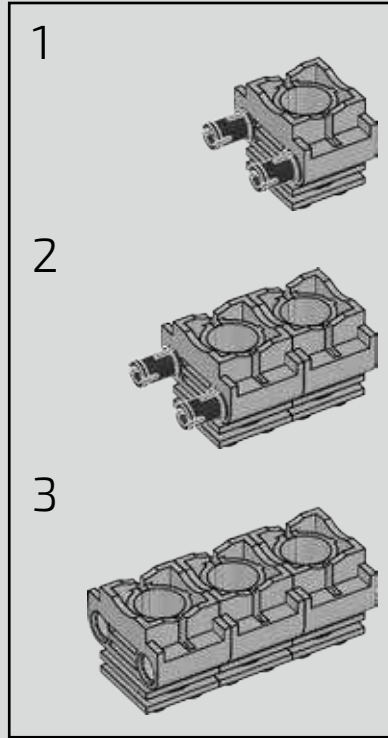

296

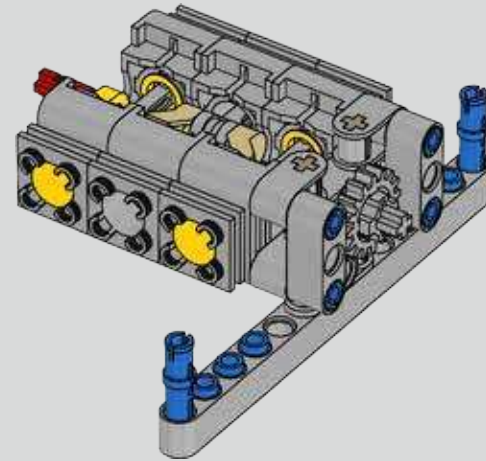

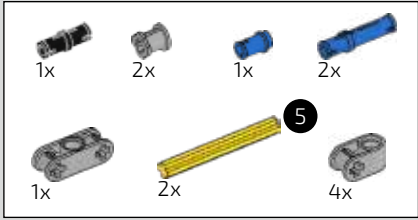

297

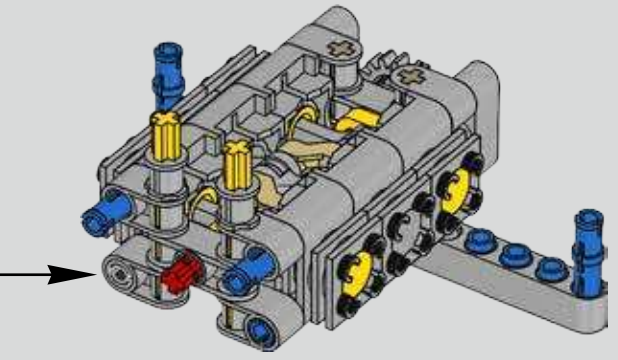
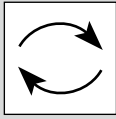
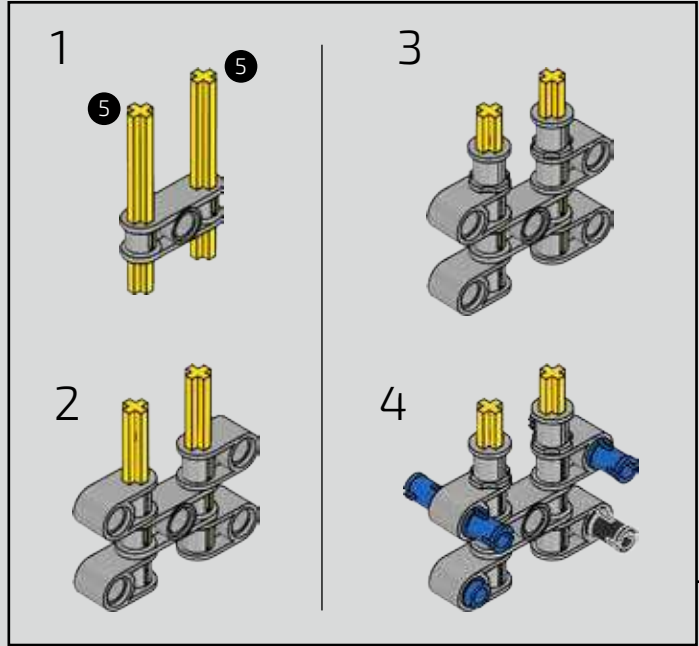

298

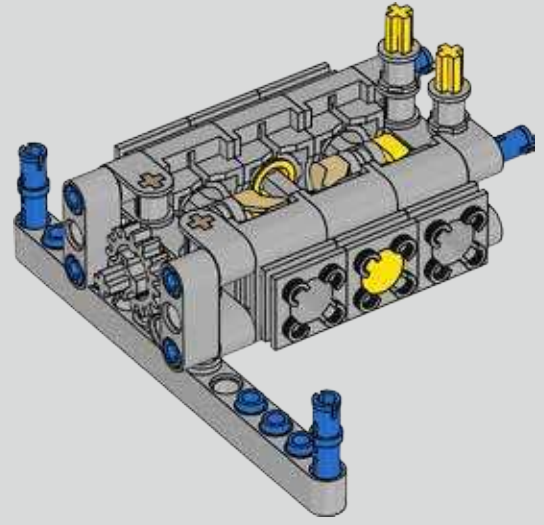
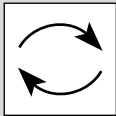

299

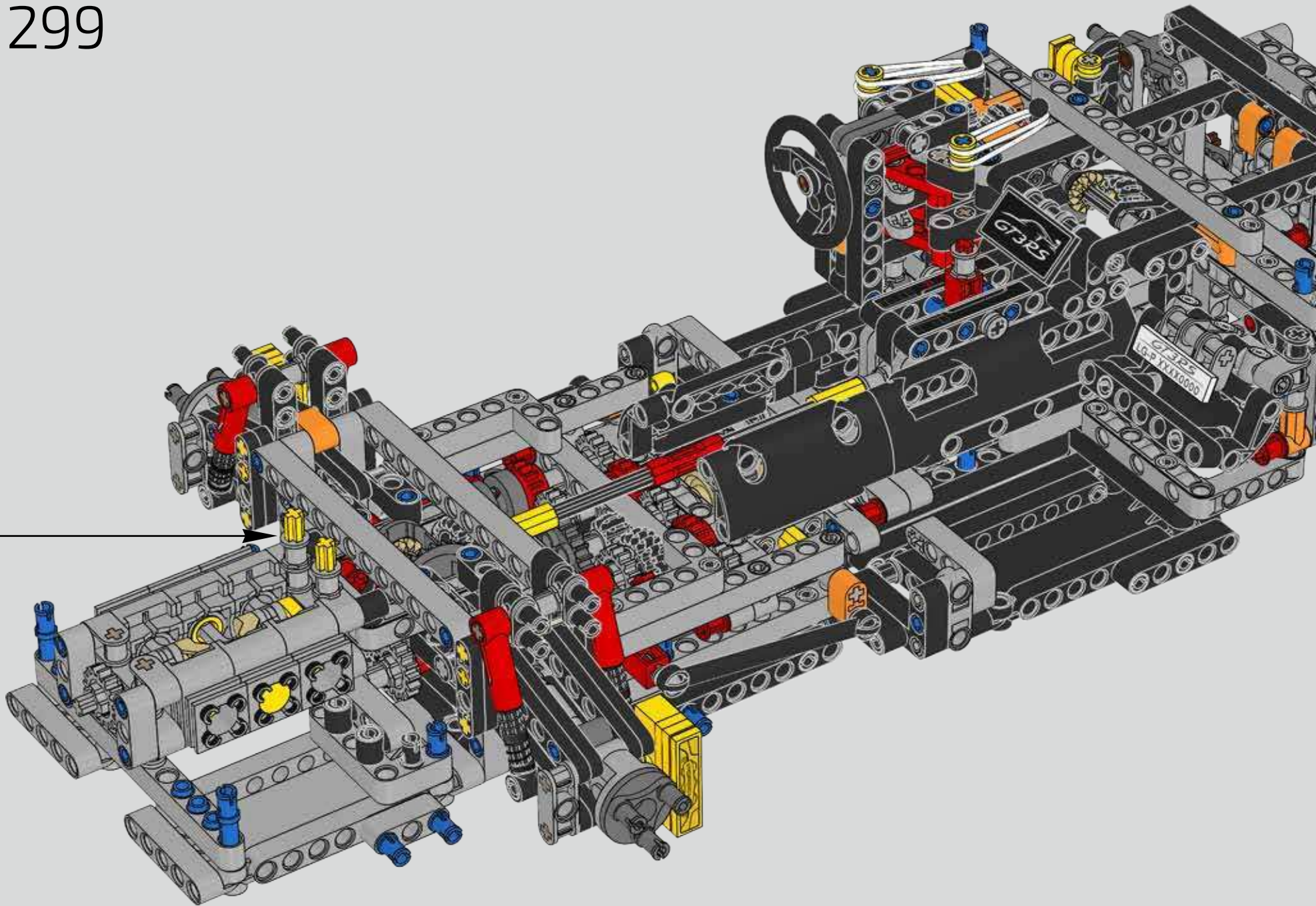

300

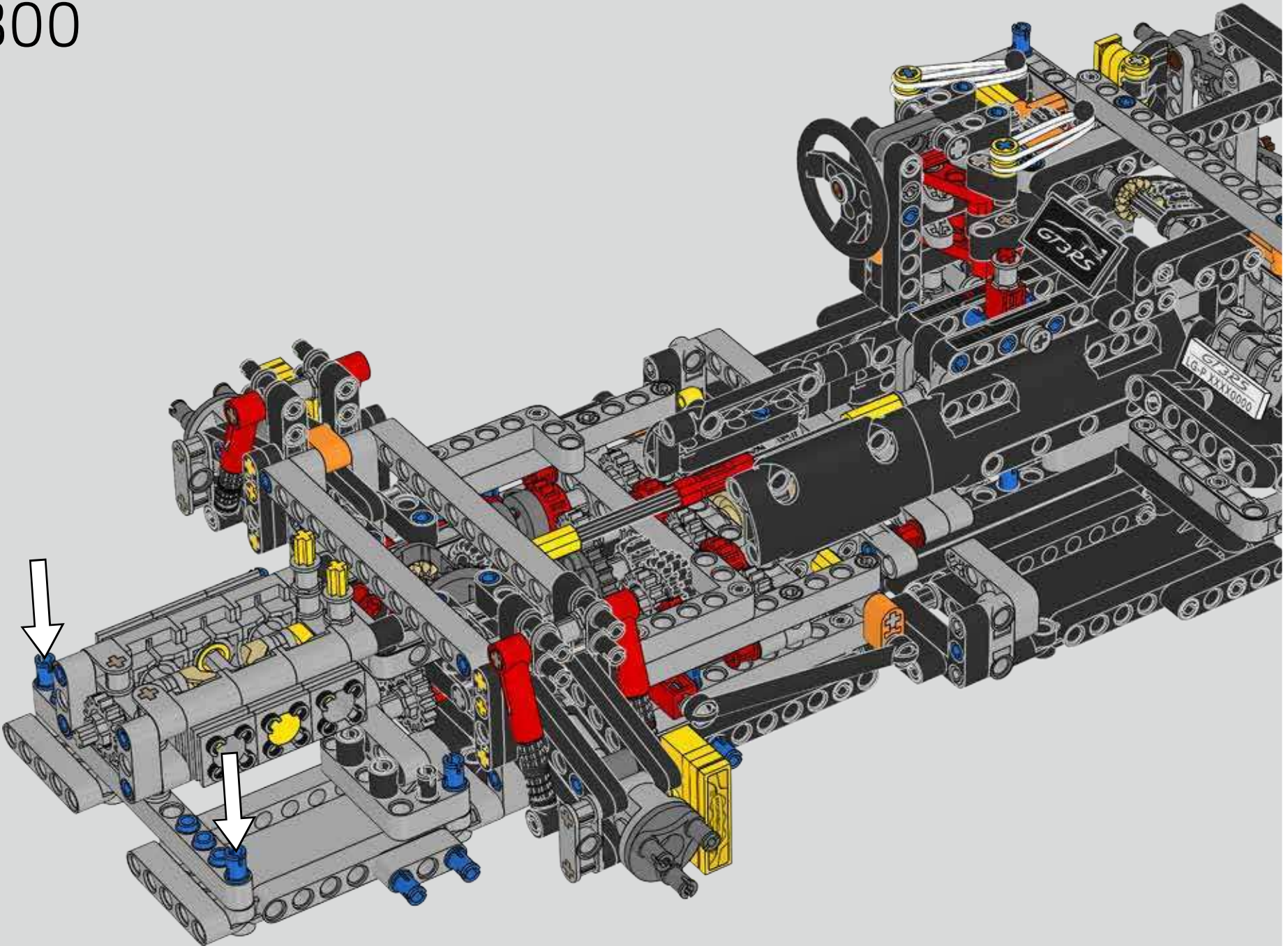

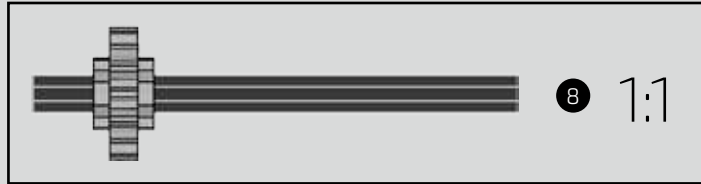
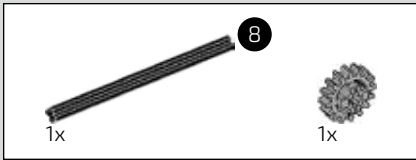

301

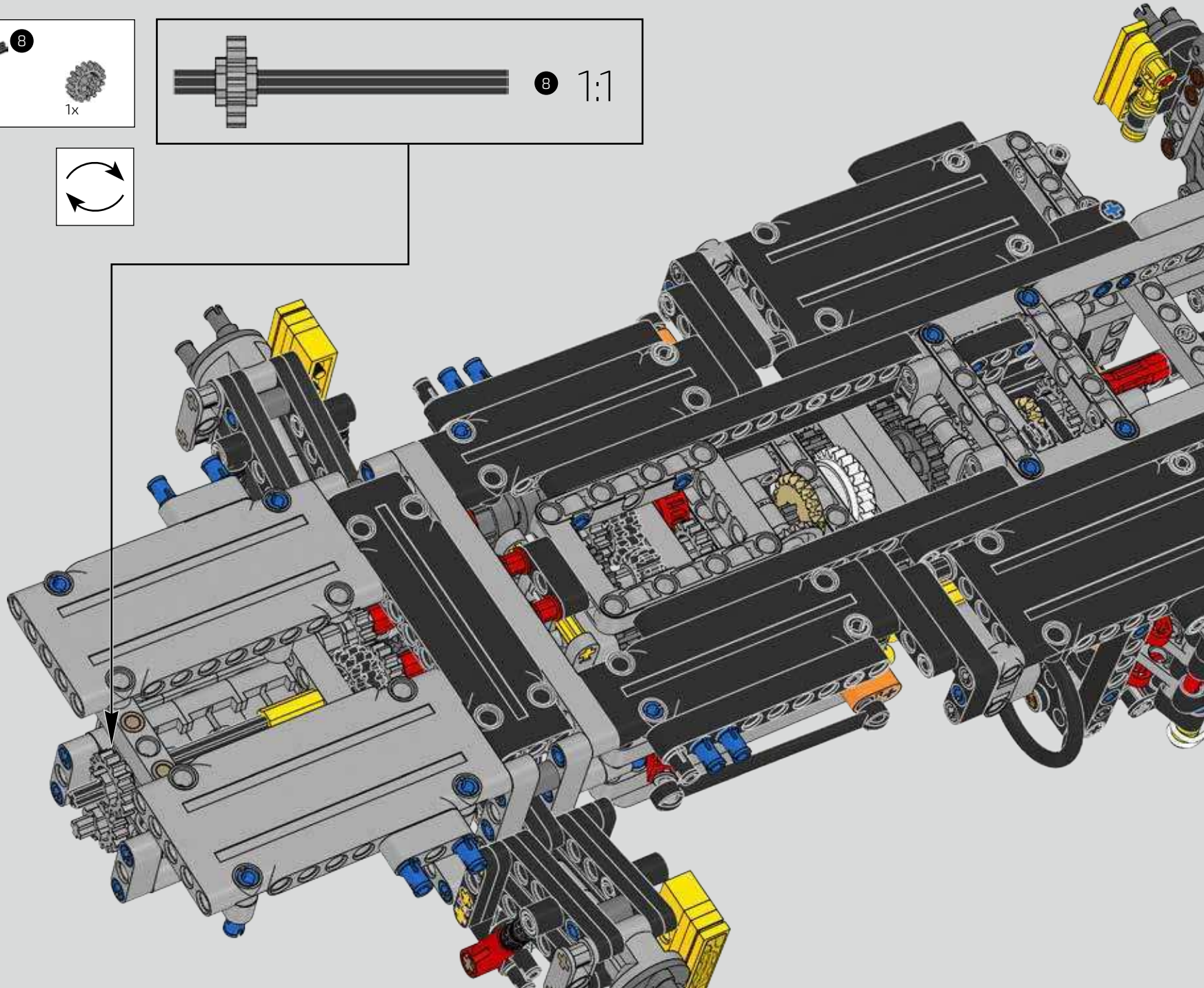
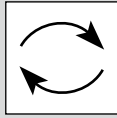

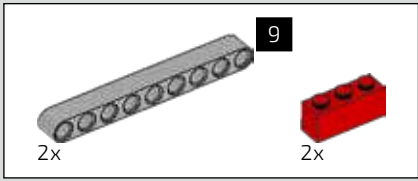

302

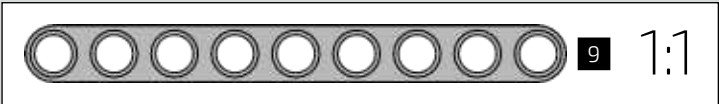
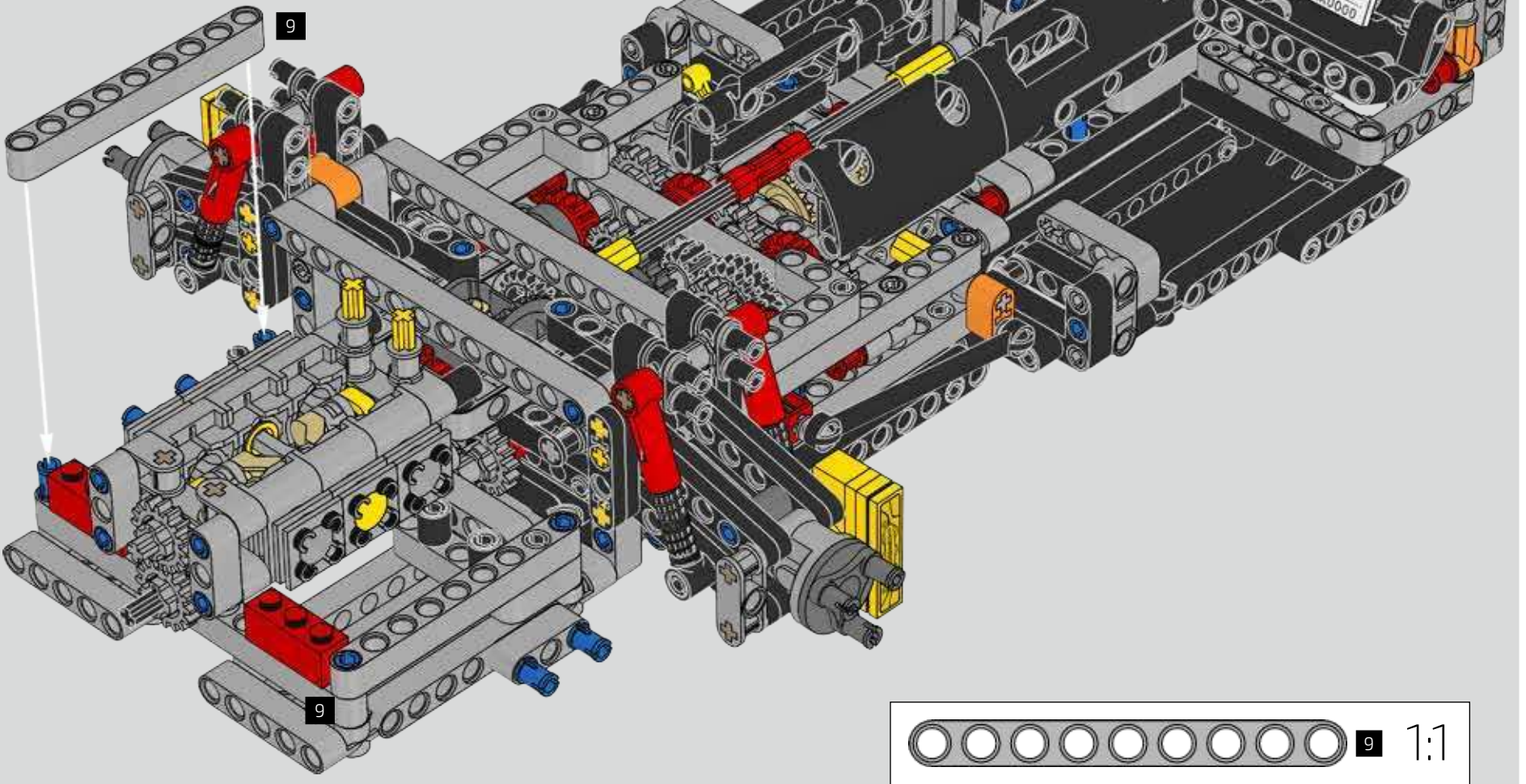
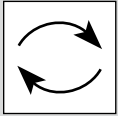

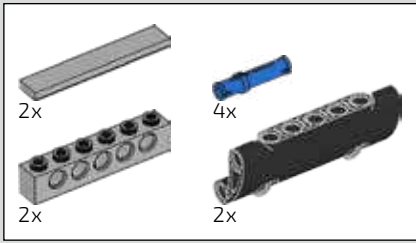

303

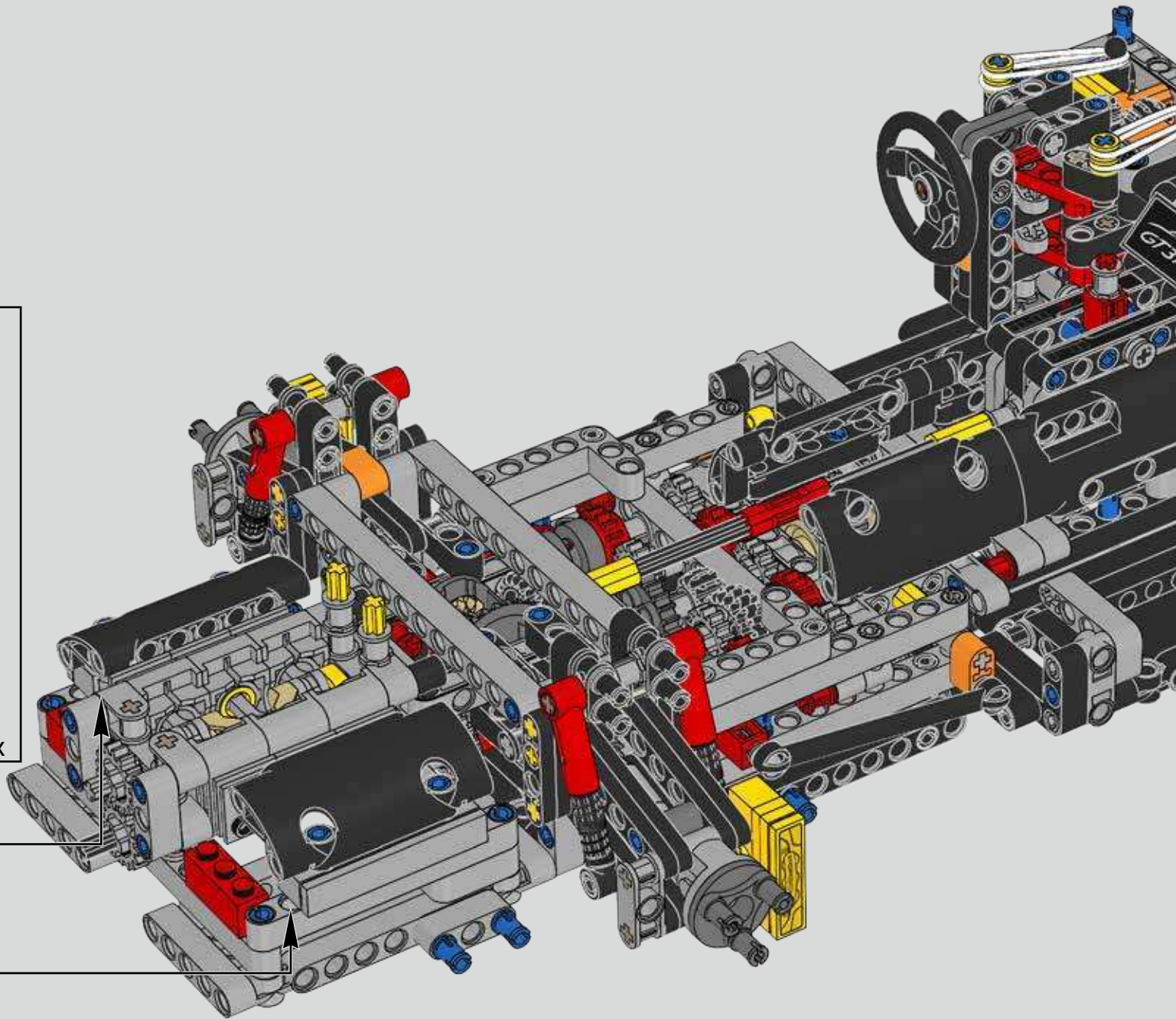
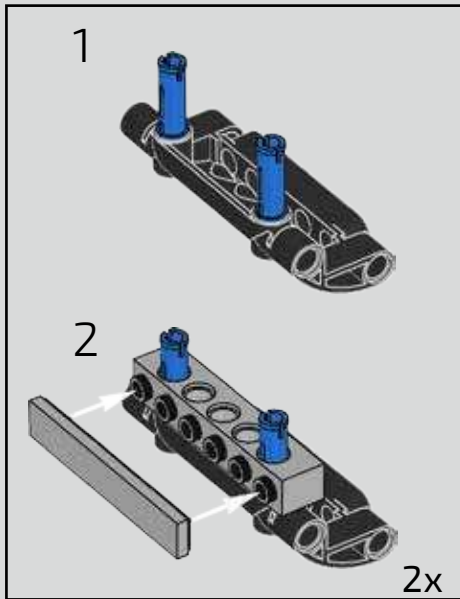

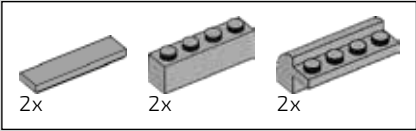

304

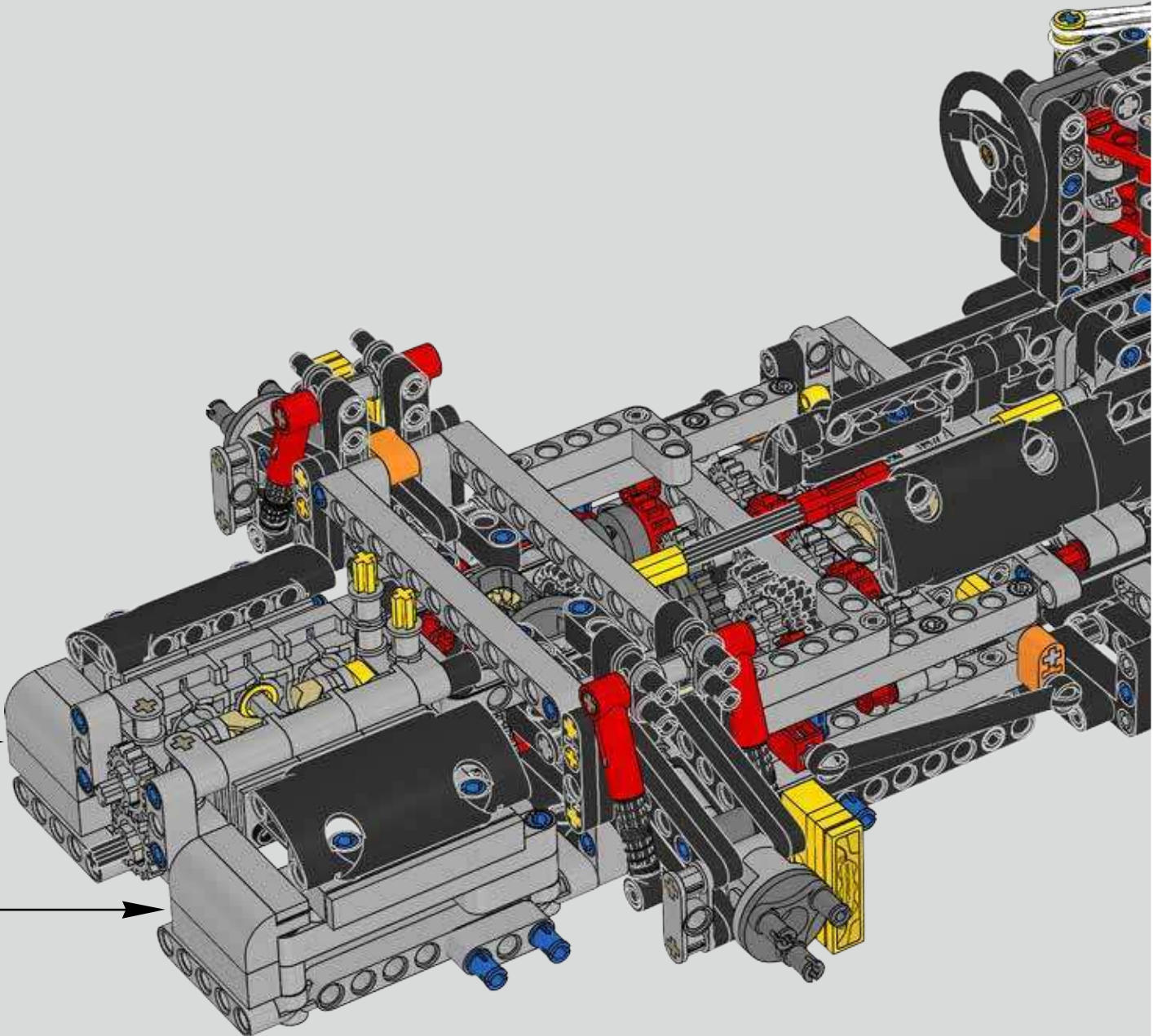
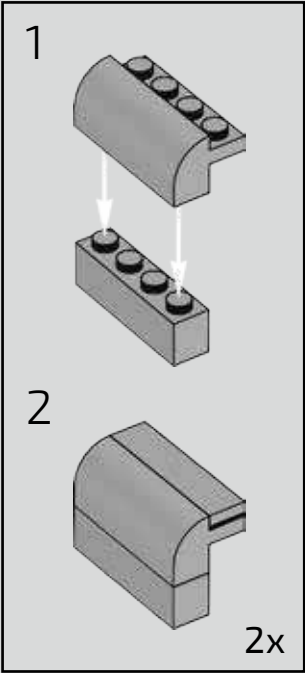

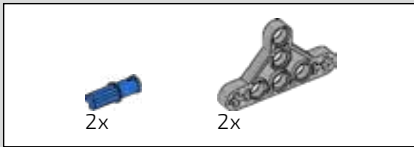

305

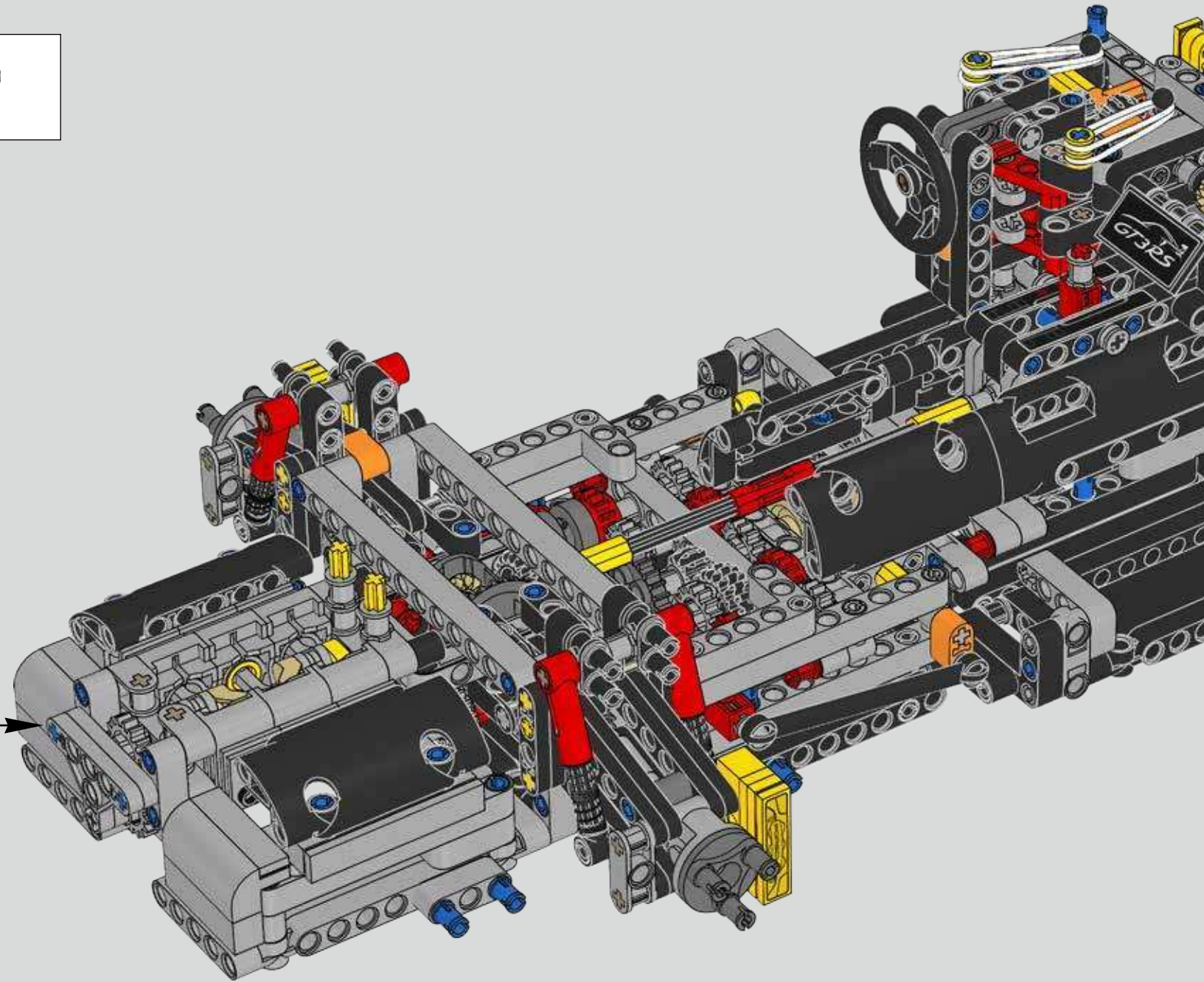
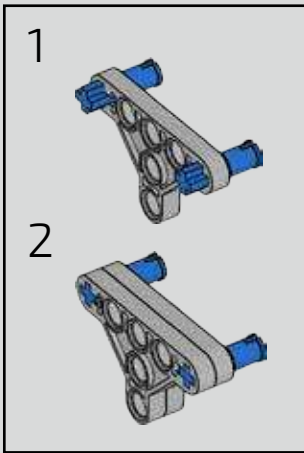

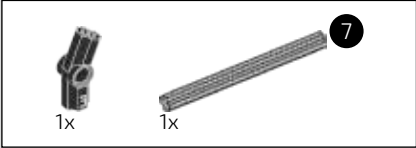
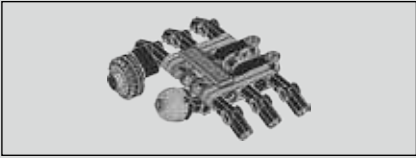

306

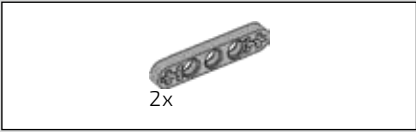
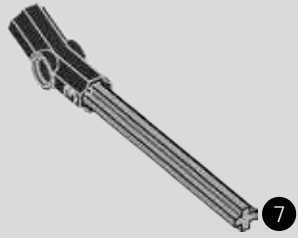

307

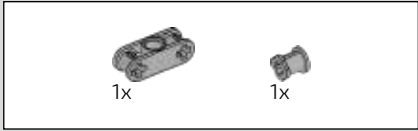
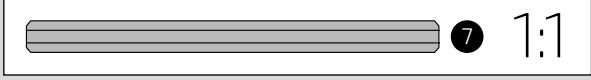
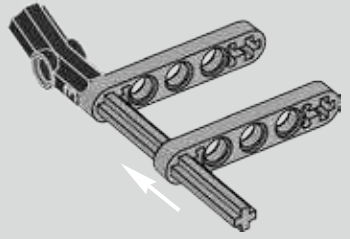

308

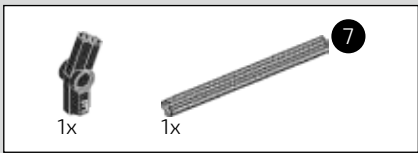
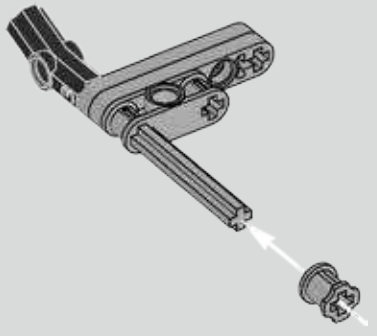

309

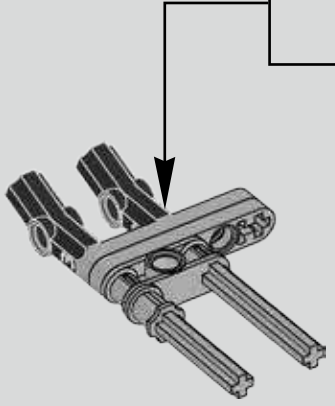
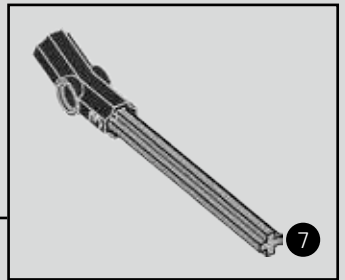

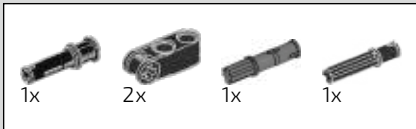

310

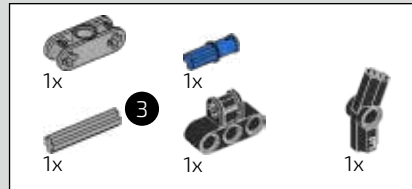
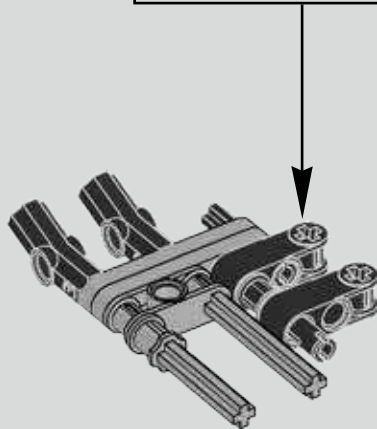
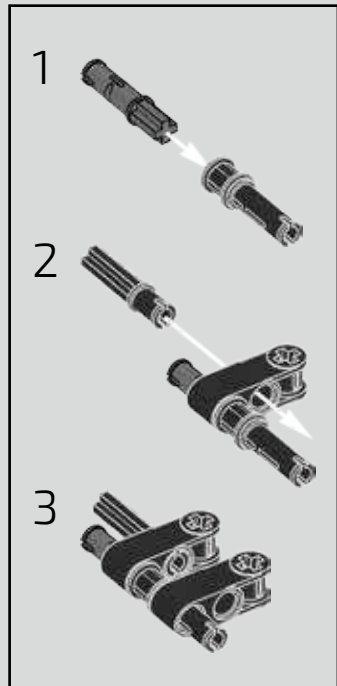

311

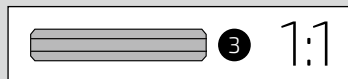
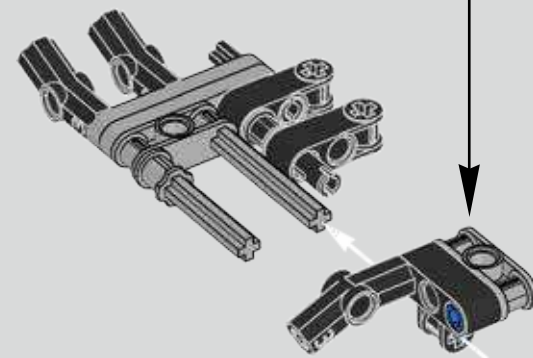
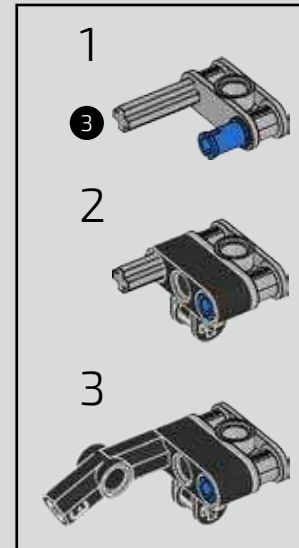



312

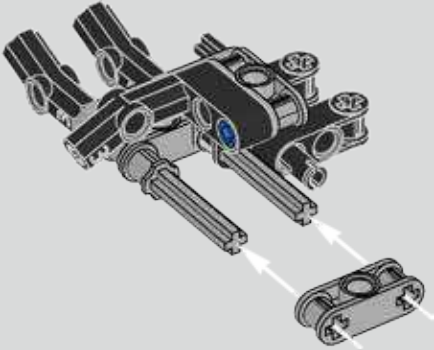

313

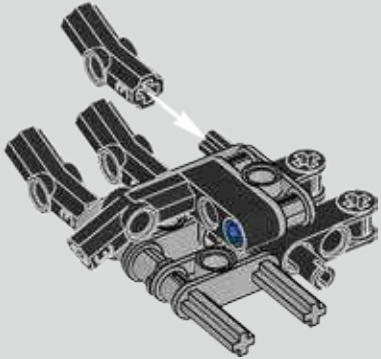

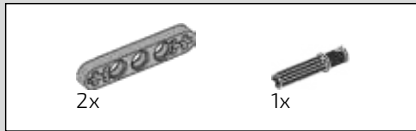

314

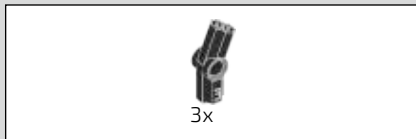
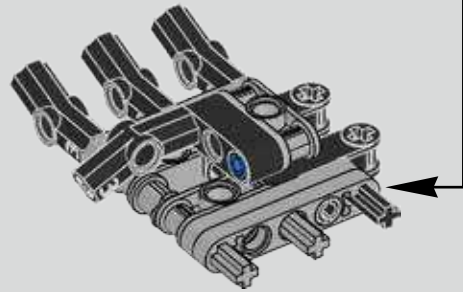
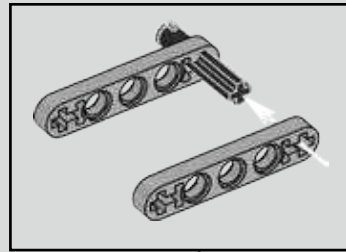

315

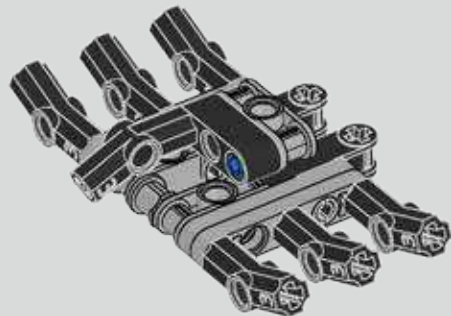

316

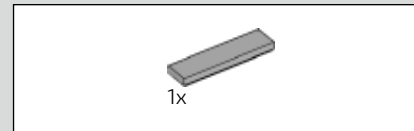
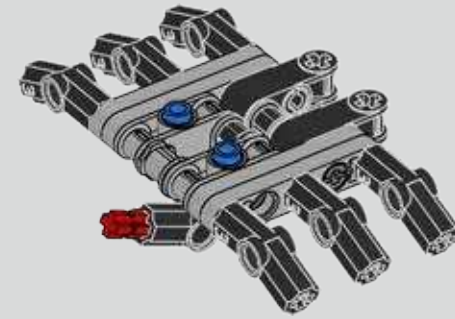
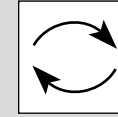

317

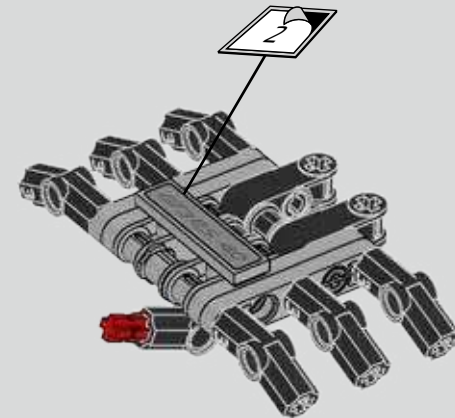

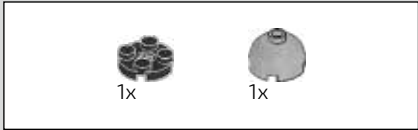

318

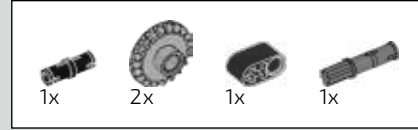
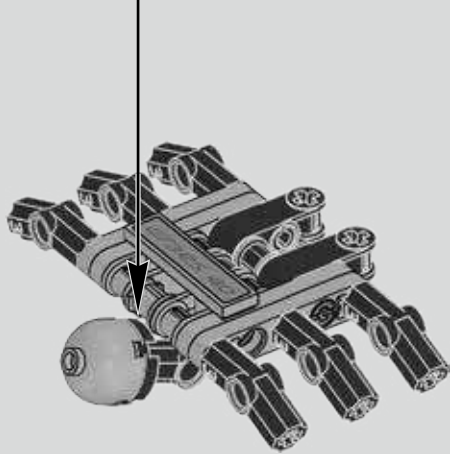
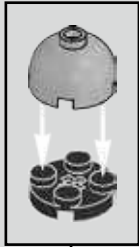

319

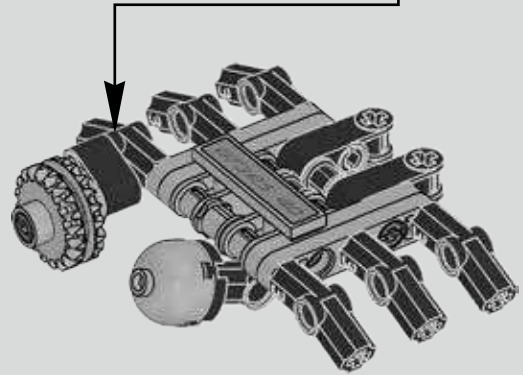
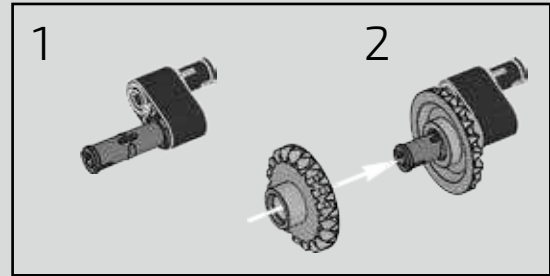

320

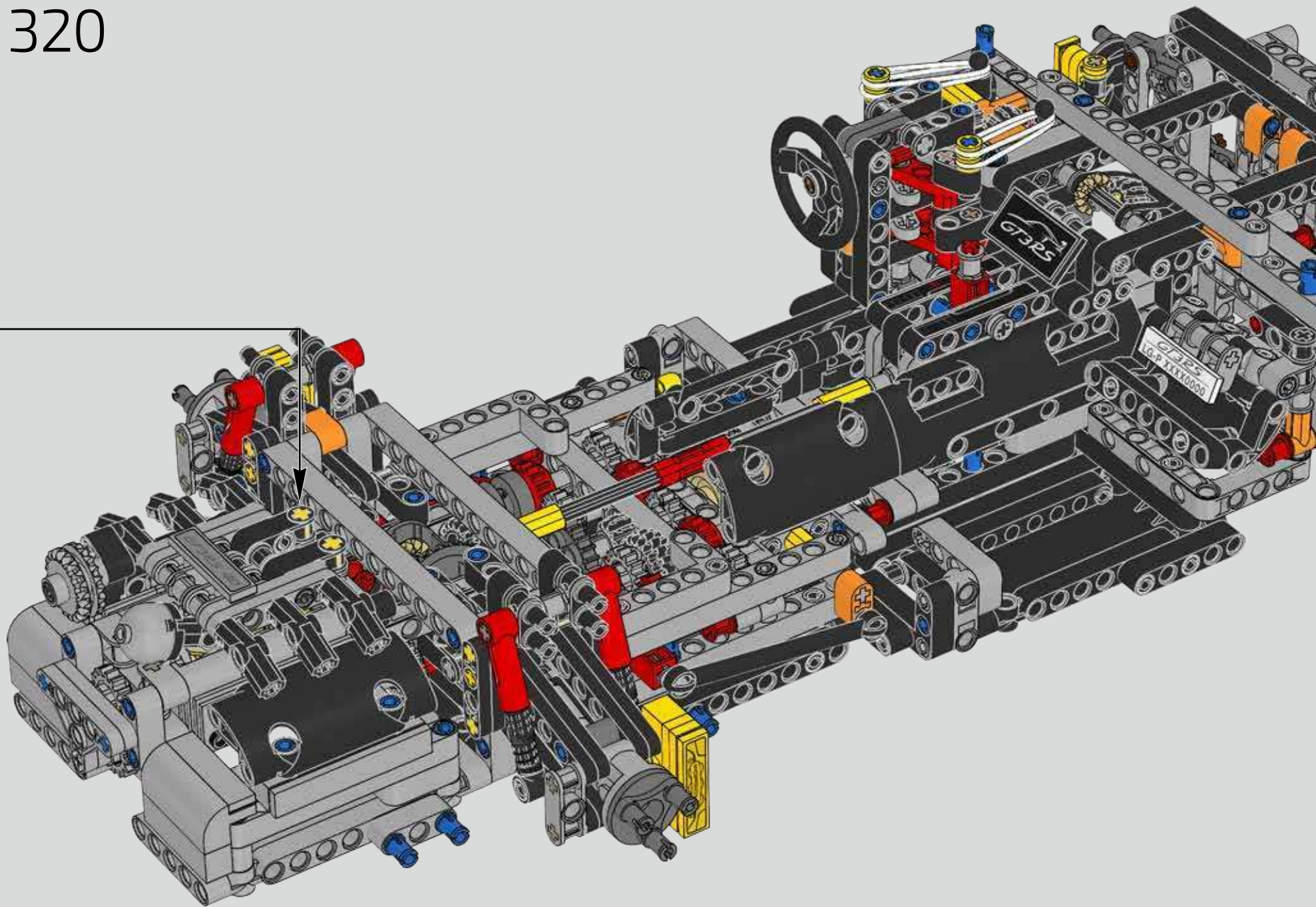

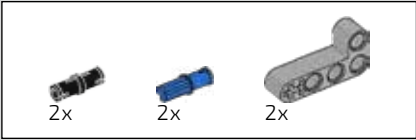

321

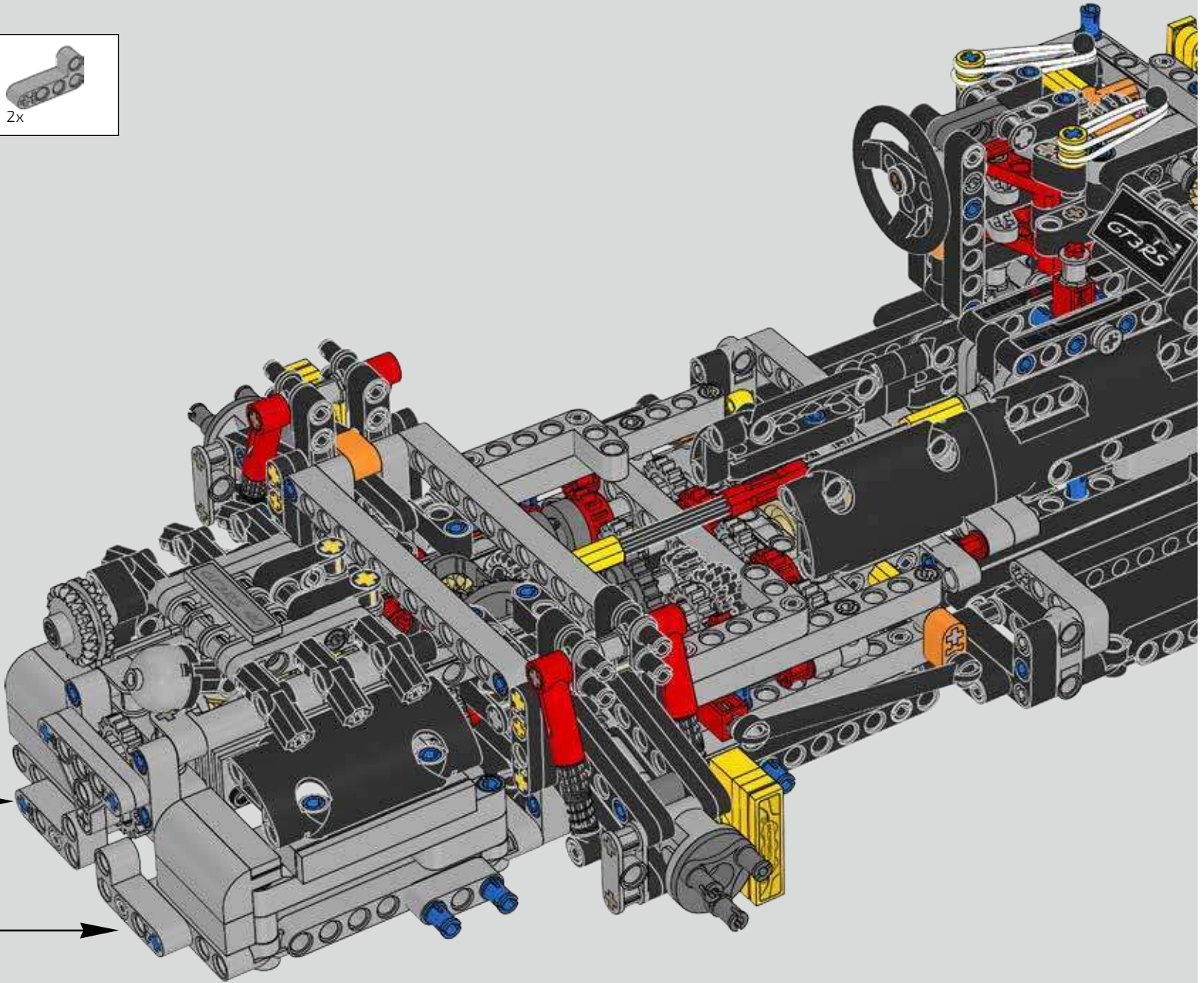
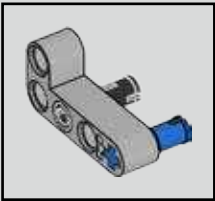
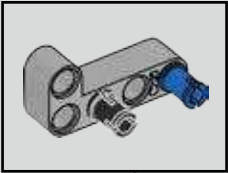



322

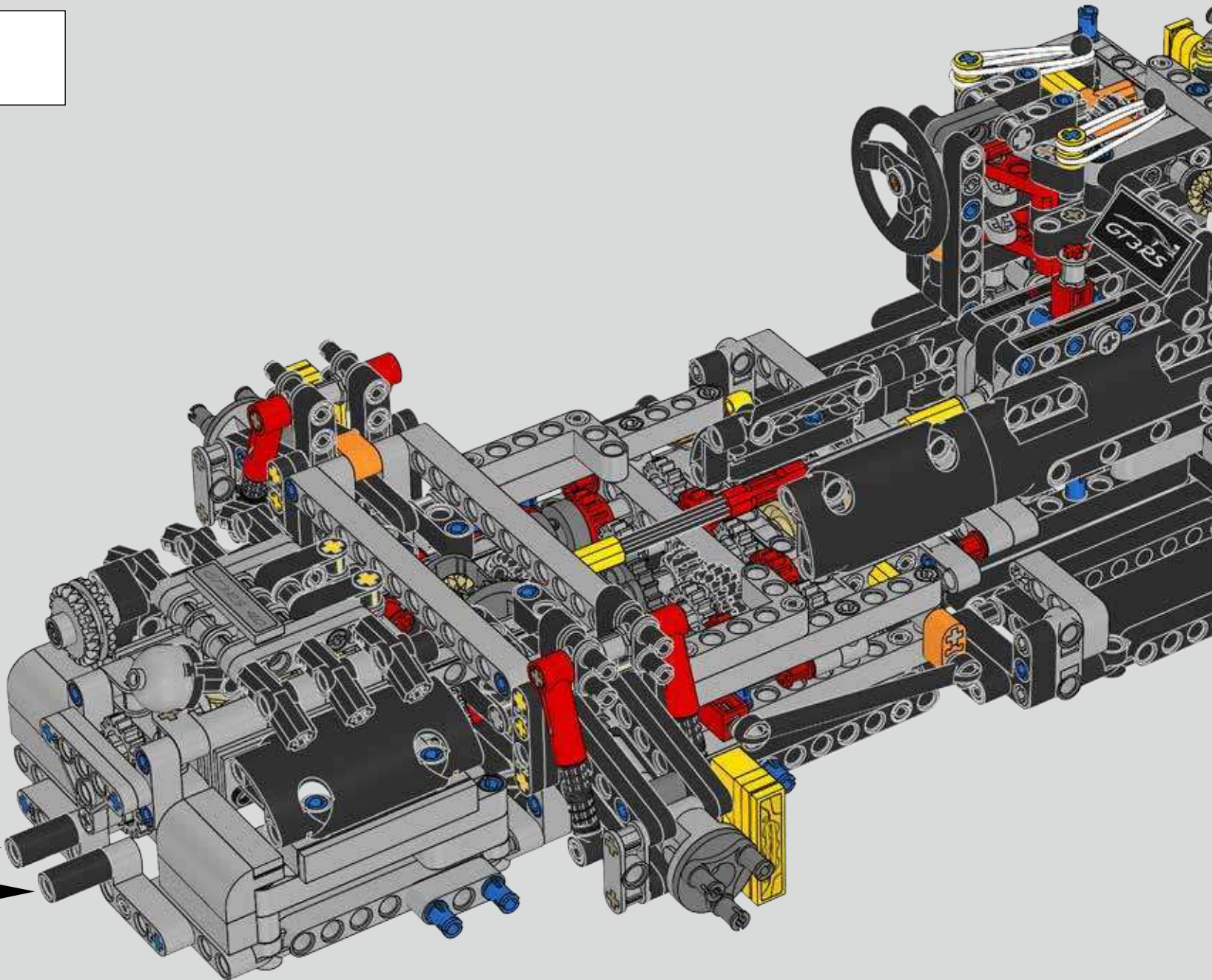
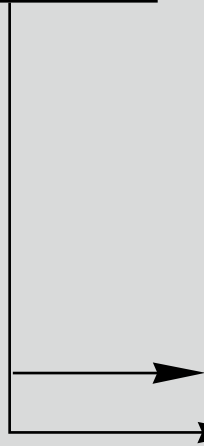
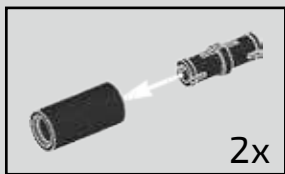

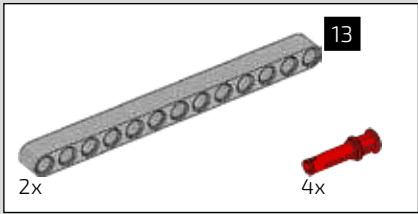

323

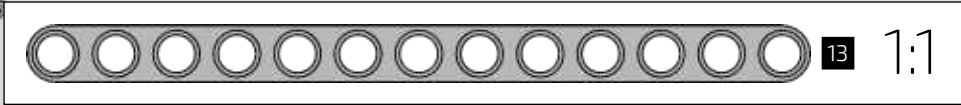
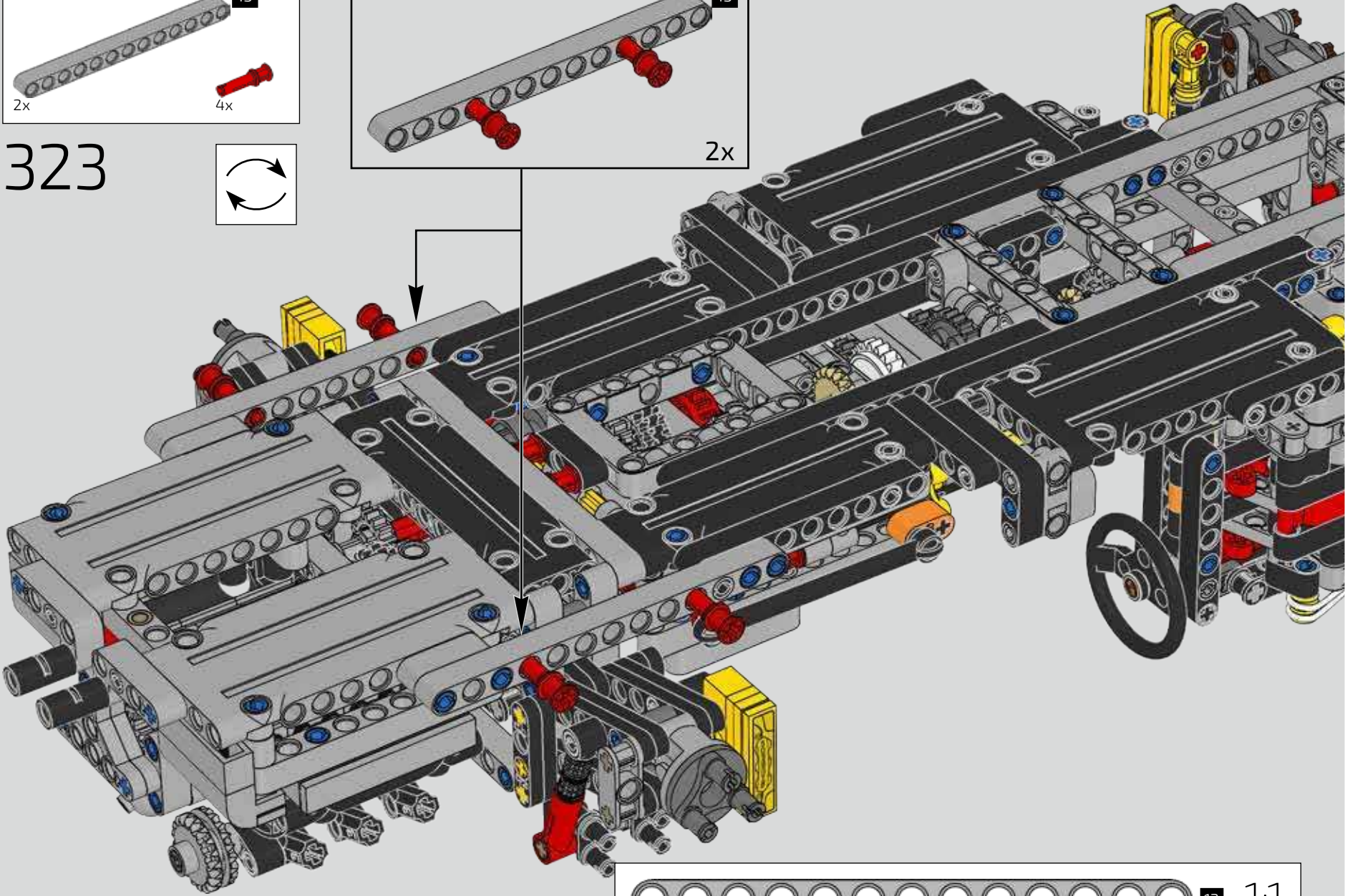
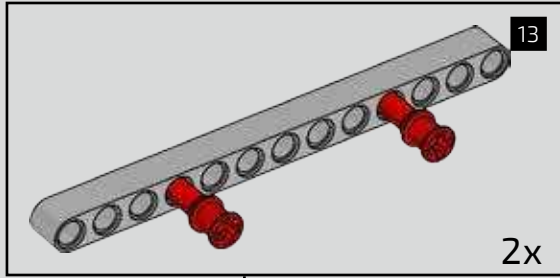
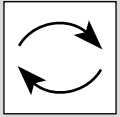



2

During production of the real 911 GT3 RS there is a stage called the 'marriage', where the drivetrain is connected to the body of the car. In this box you build the floor plan of the 911 GT3 RS, complete with seats and roll cage, before placing it over the drivetrain in a similar way to the production of the real 911 GT3 RS.

Bei der Fertigung des echten 911 GT3 RS gibt es einen Produktionsschritt, der als „Hochzeit“ bezeichnet wird. Dabei wird der Antriebsstrang mit der Karosserie zusammengeführt. Mit dieser Box baust du die Grundstruktur des 911 GT3 RS, einschließlich der Sitze und des Überrollkäfigs, bevor du ihn über dem Antriebsstrang platzierst – fast so wie bei der Produktion des echten 911 GT3 RS.



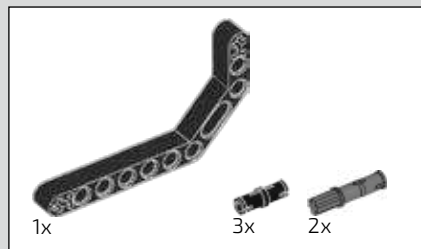

324

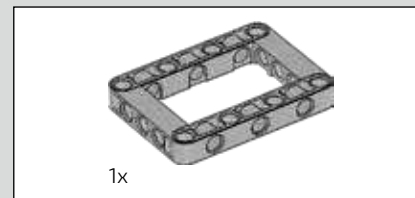
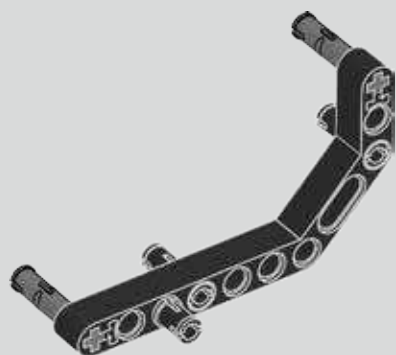

325

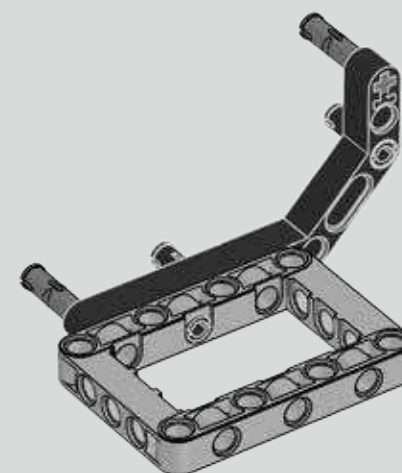

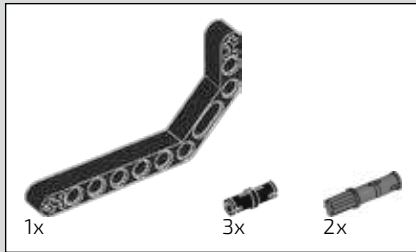

326

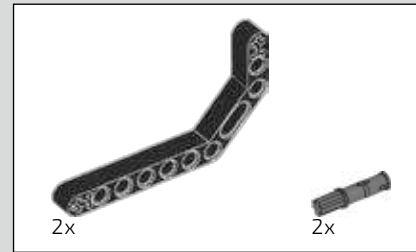
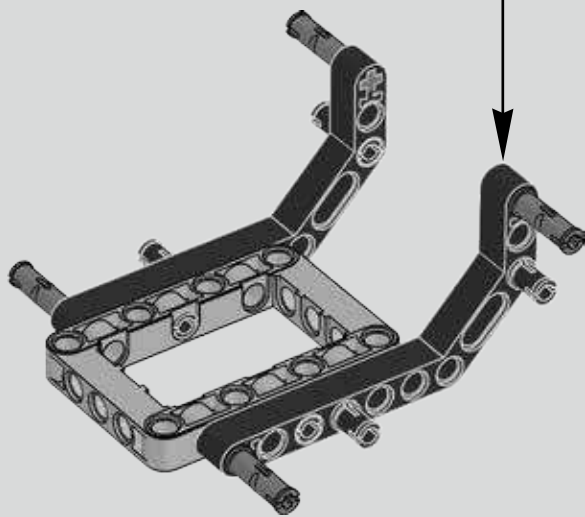
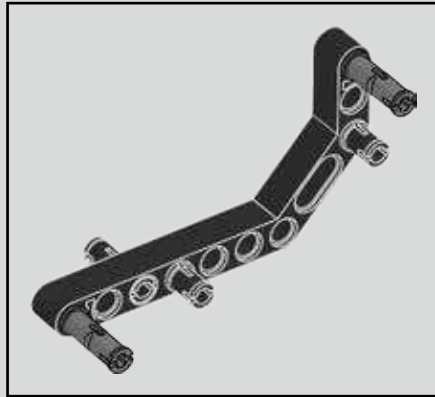

327

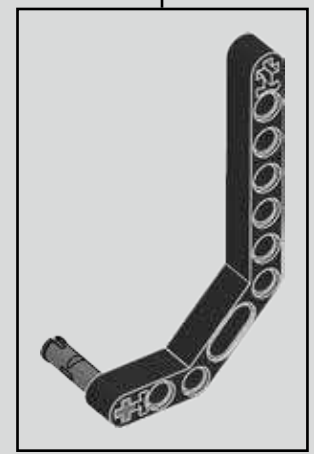
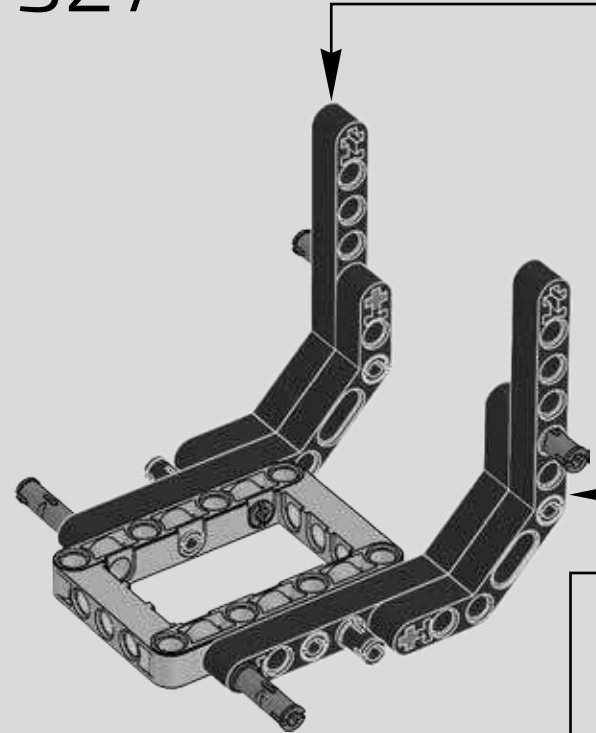
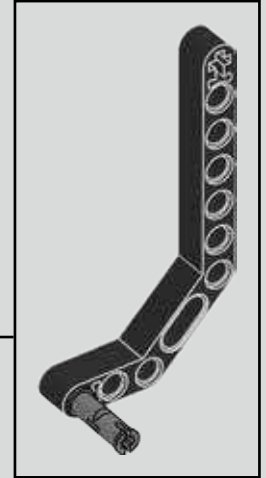

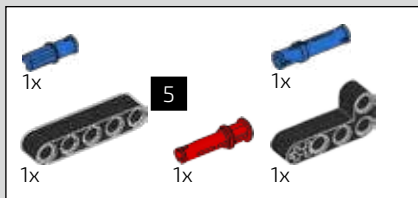

328

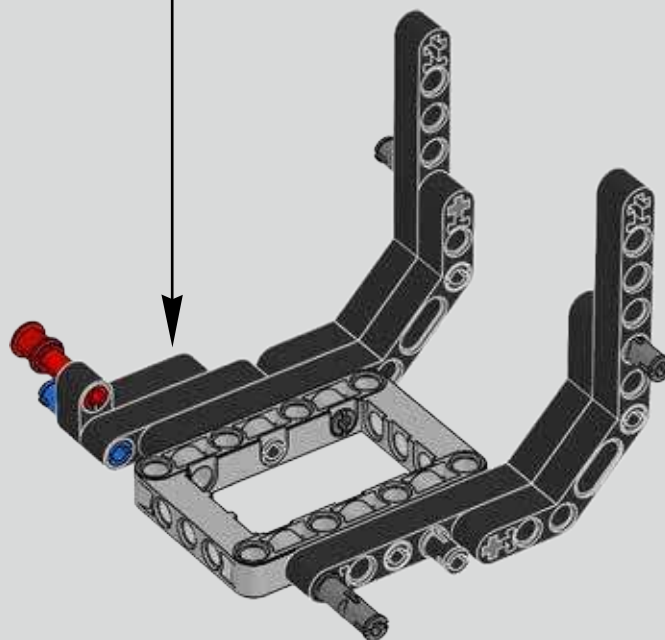
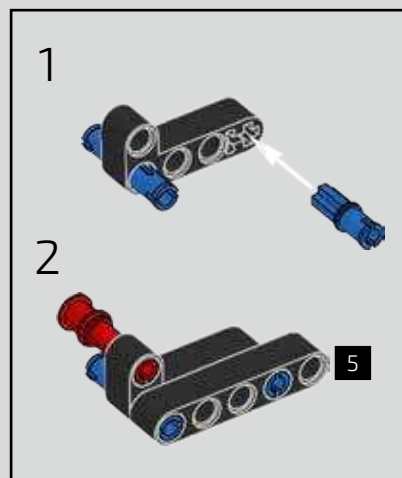

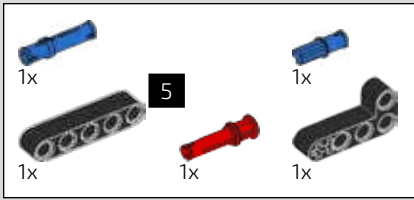

329

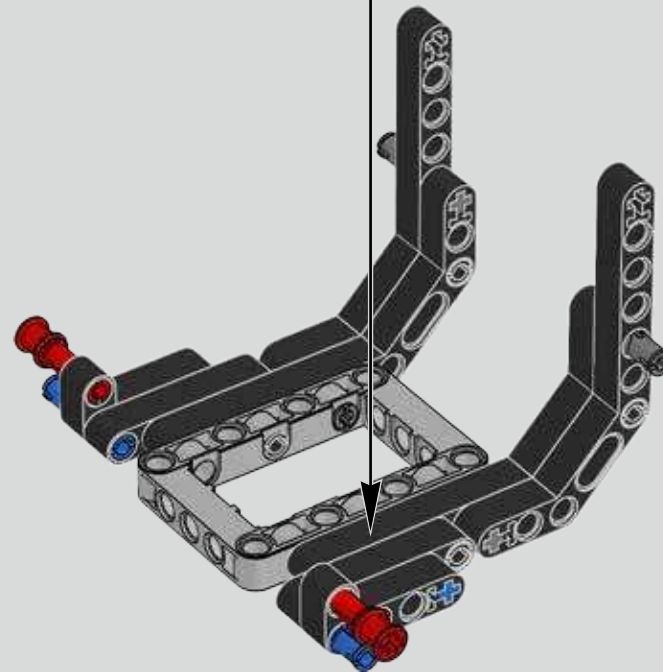
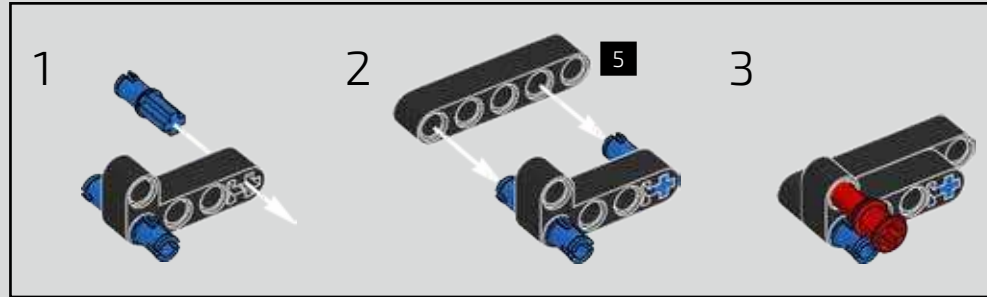

330

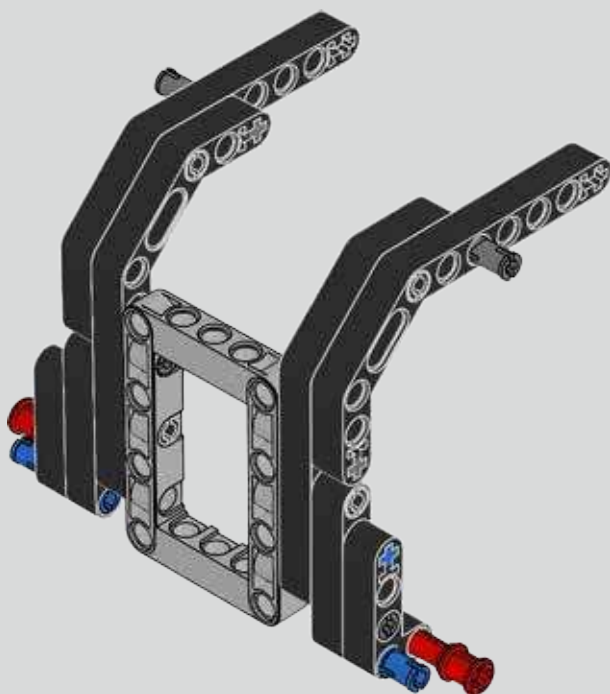
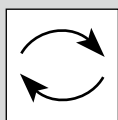

331

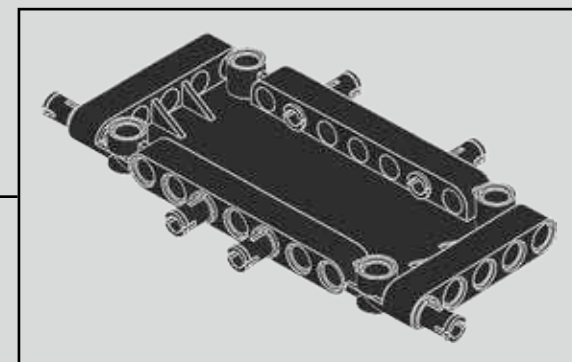
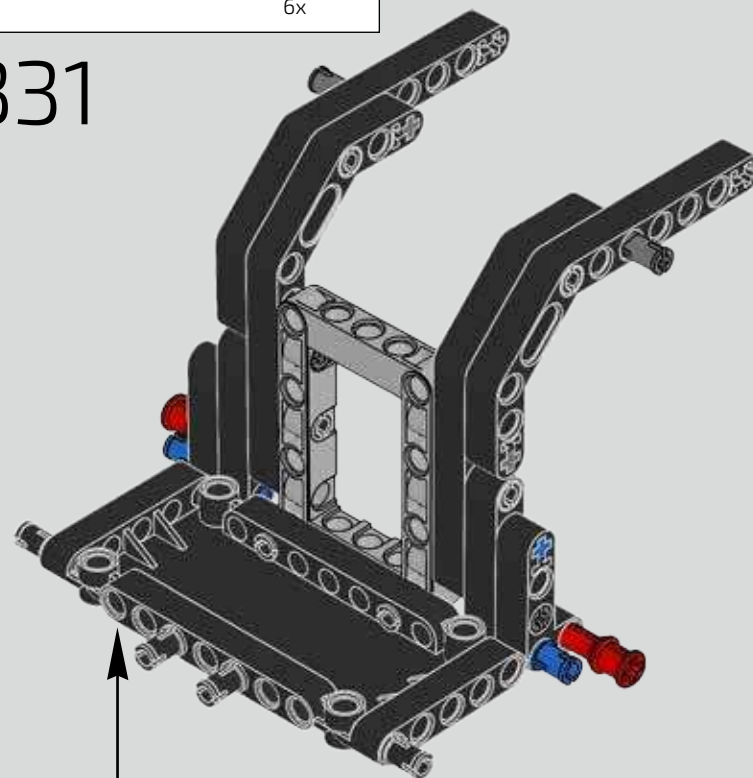

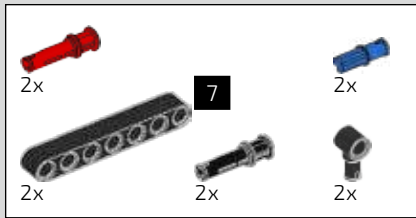

332

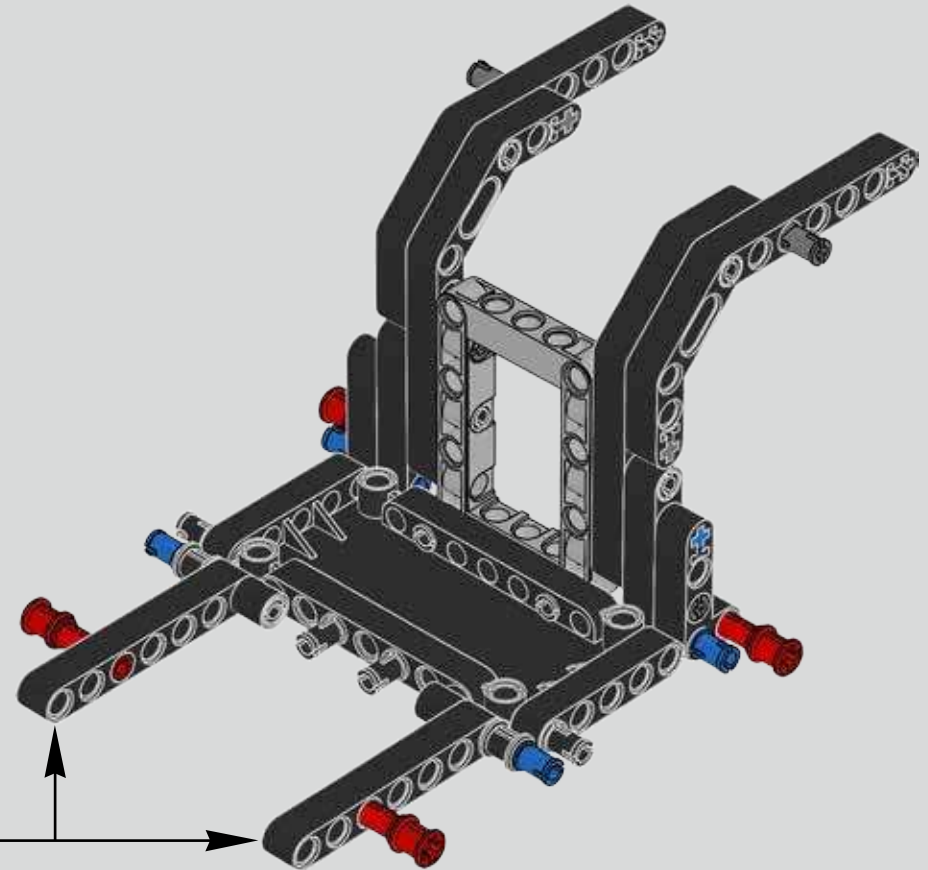
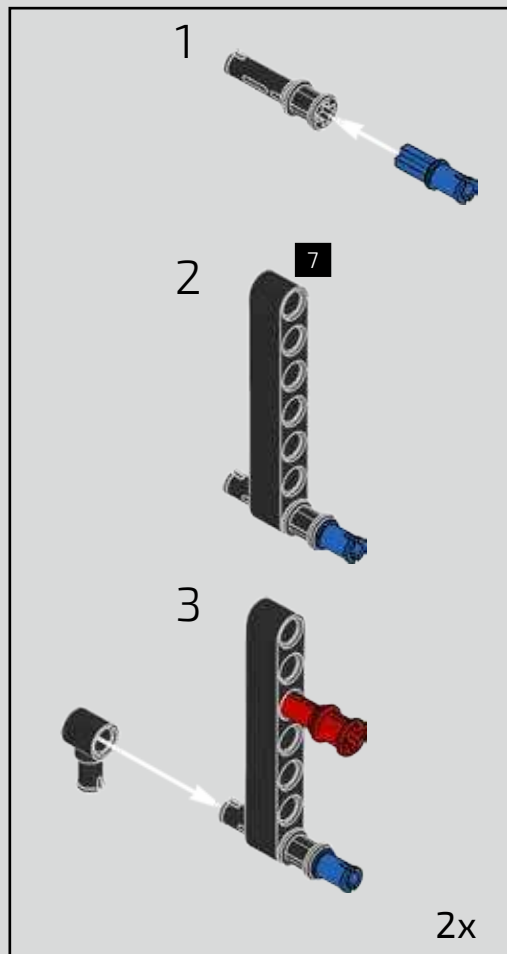



333

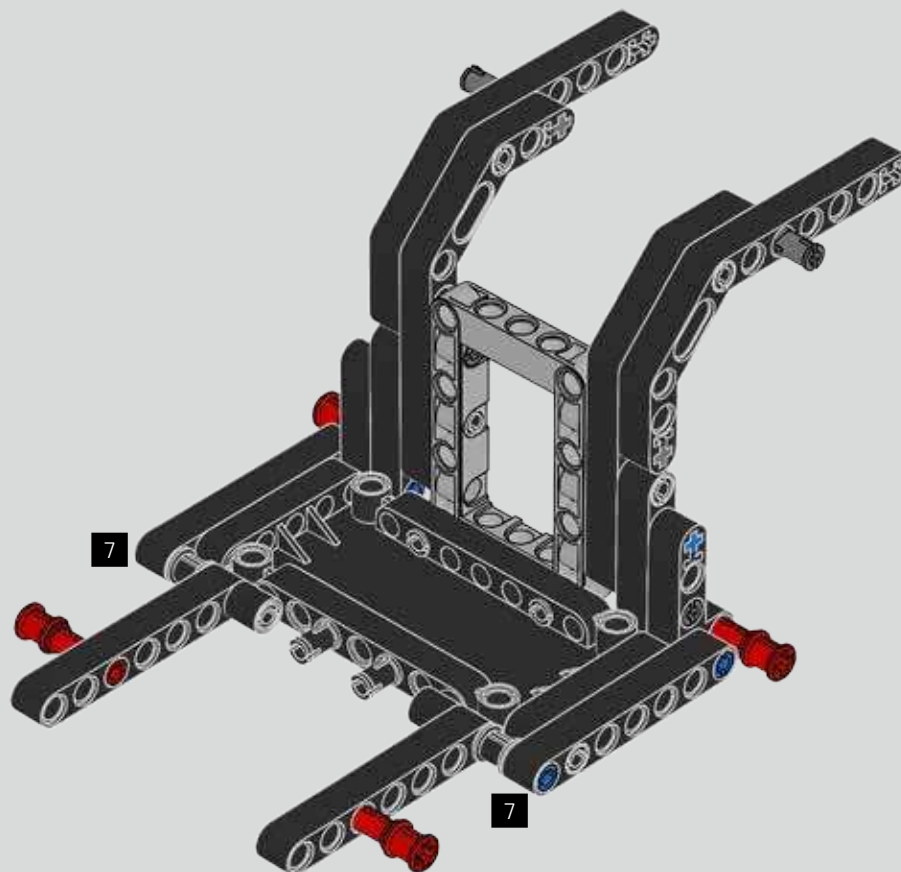

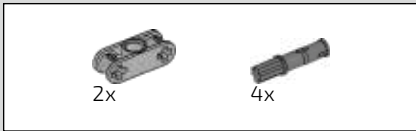

334

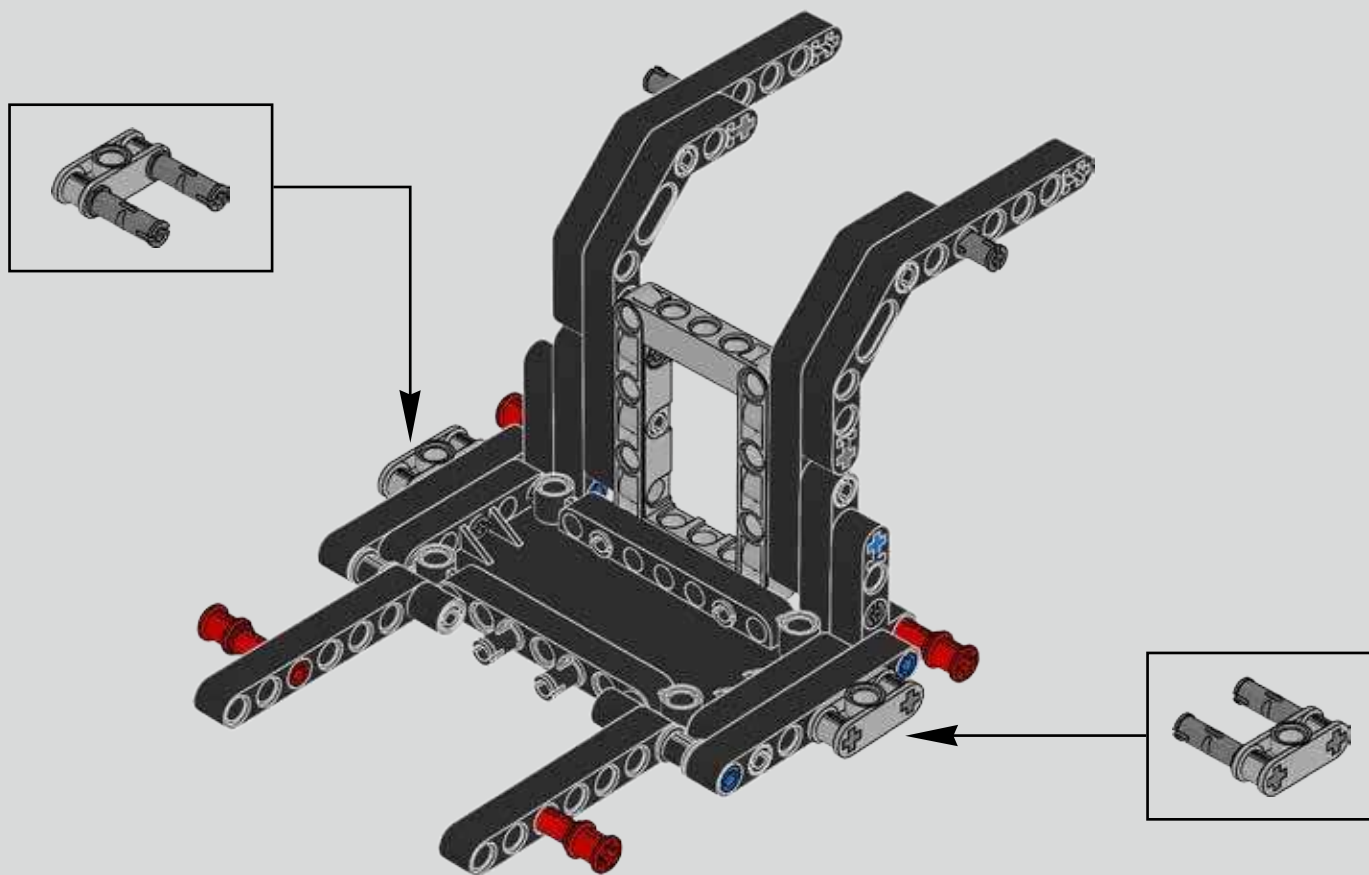

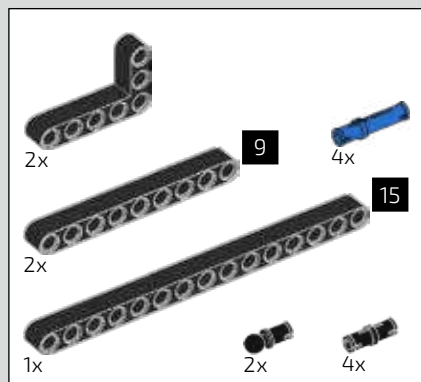

335

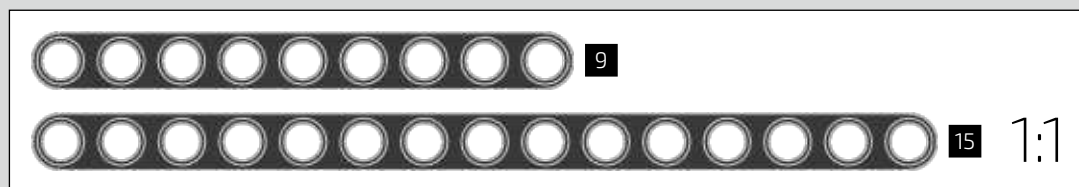
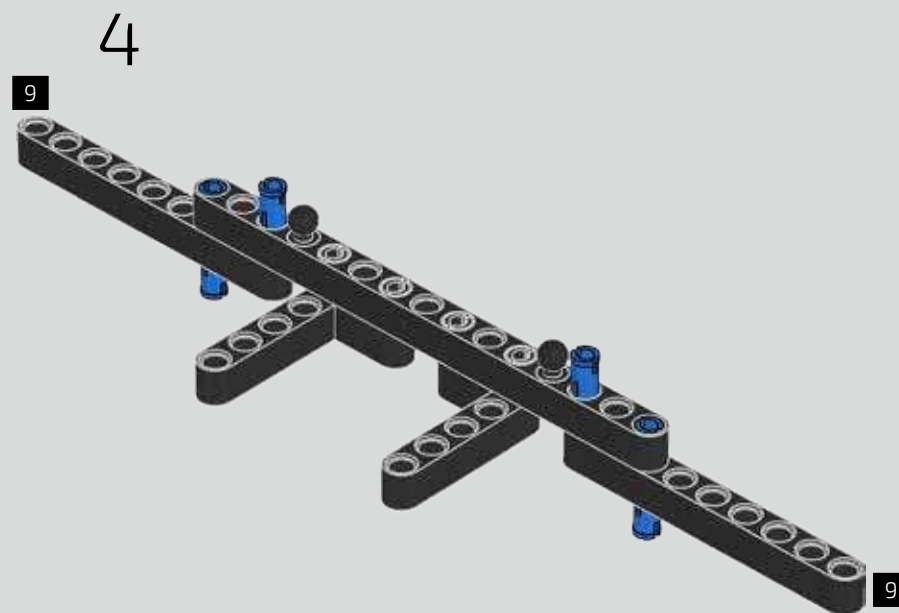
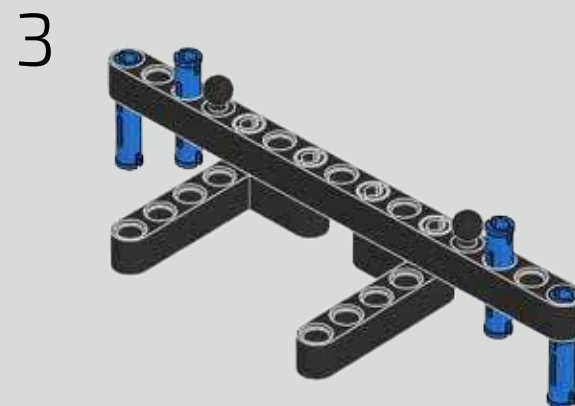
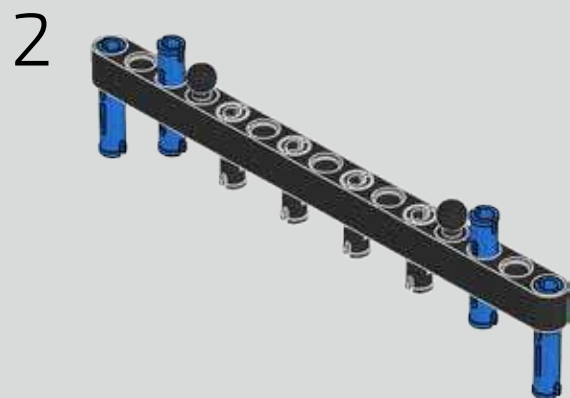
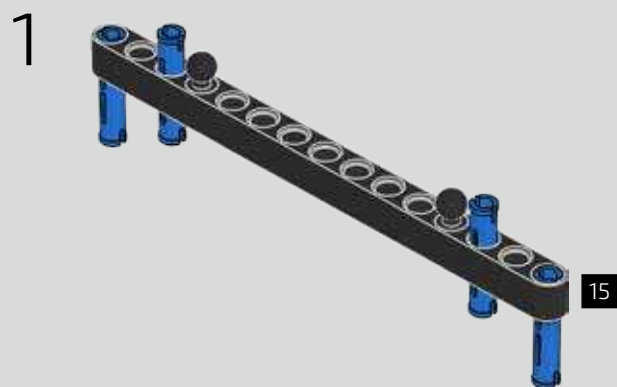

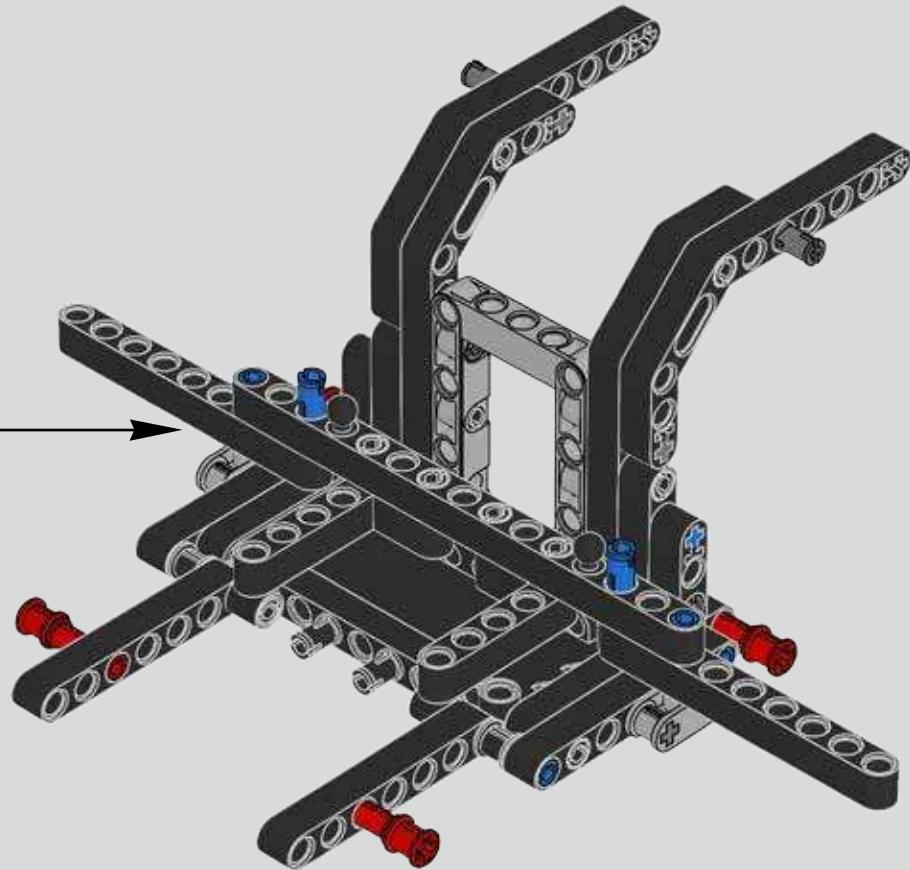

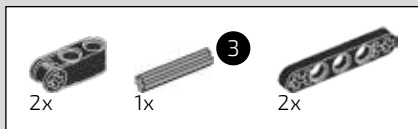

336

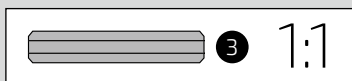
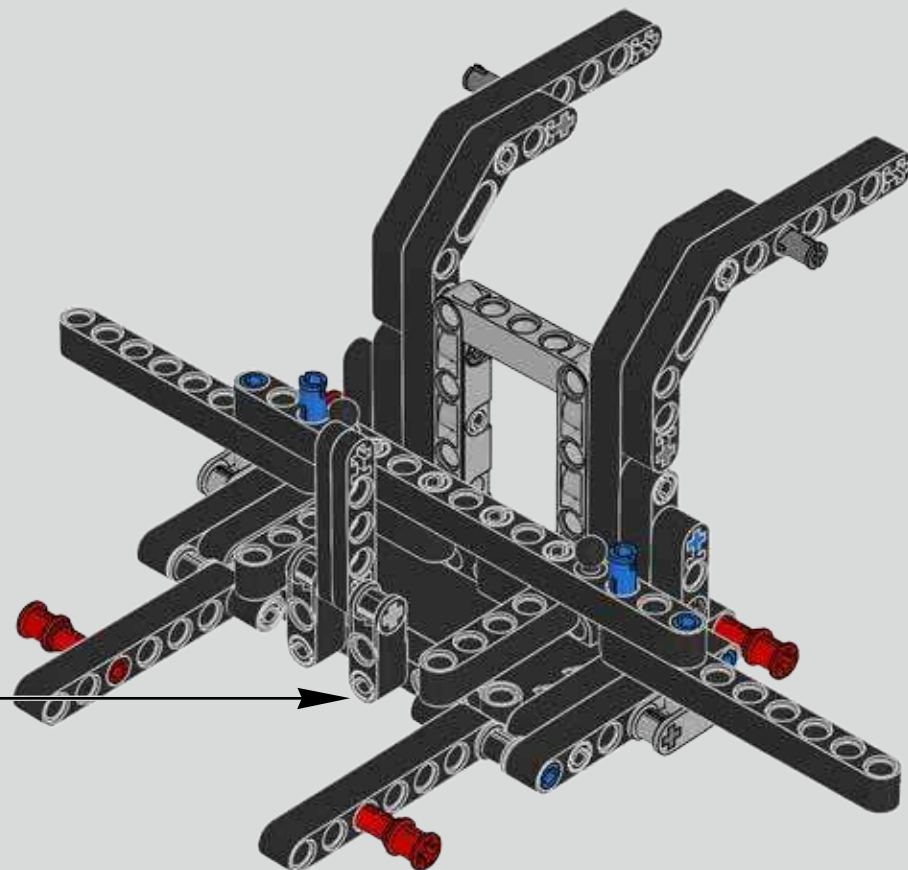
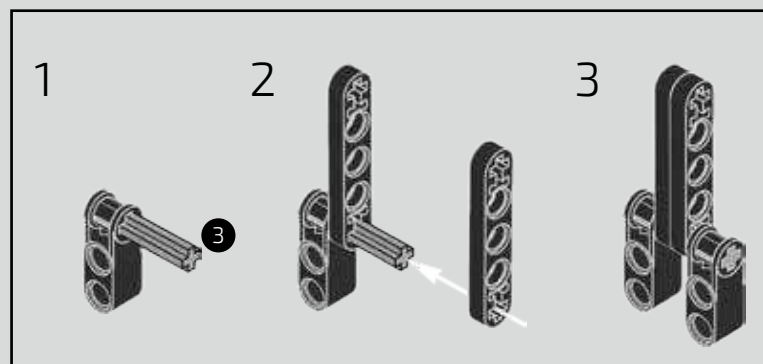



337

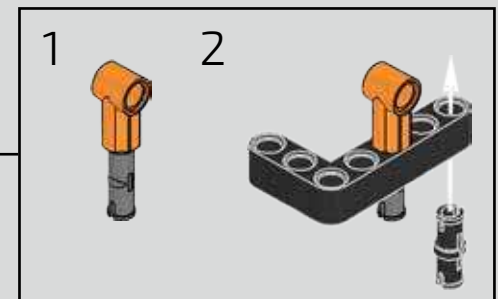
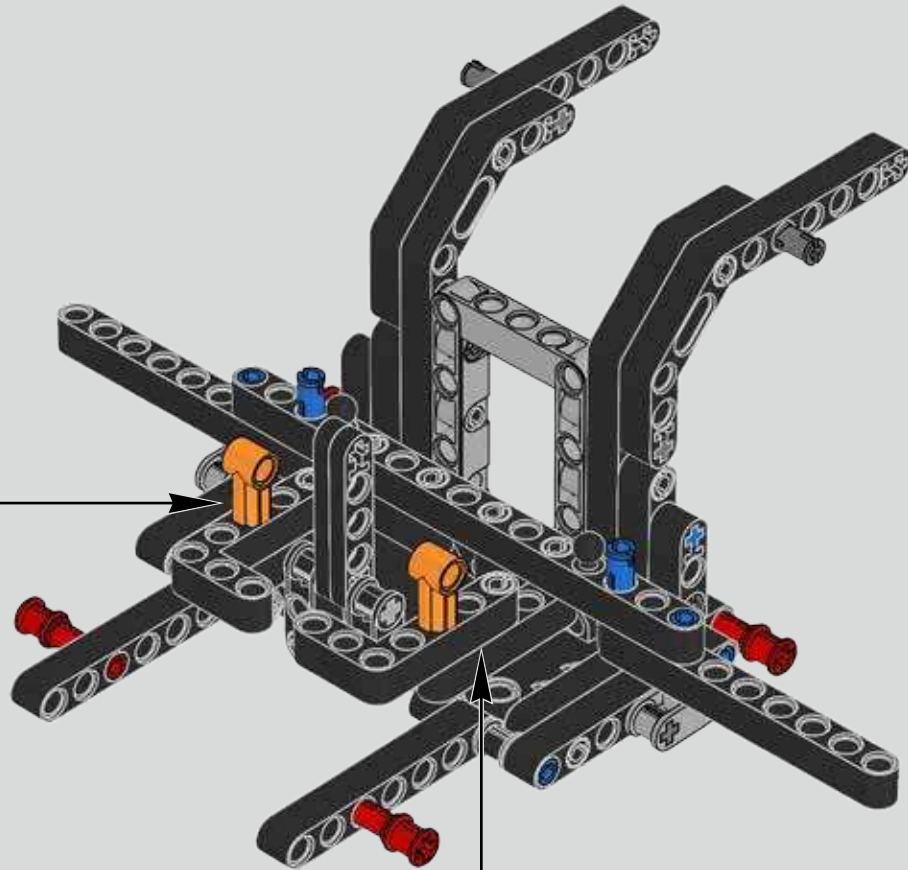
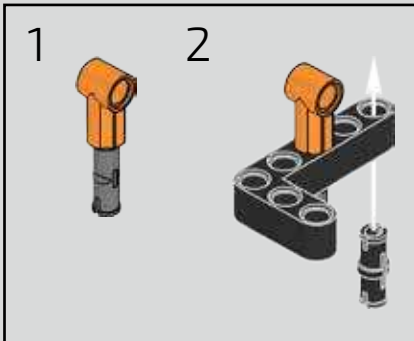

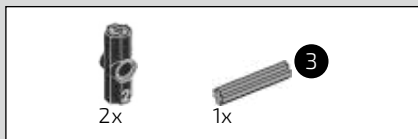

338

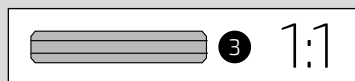
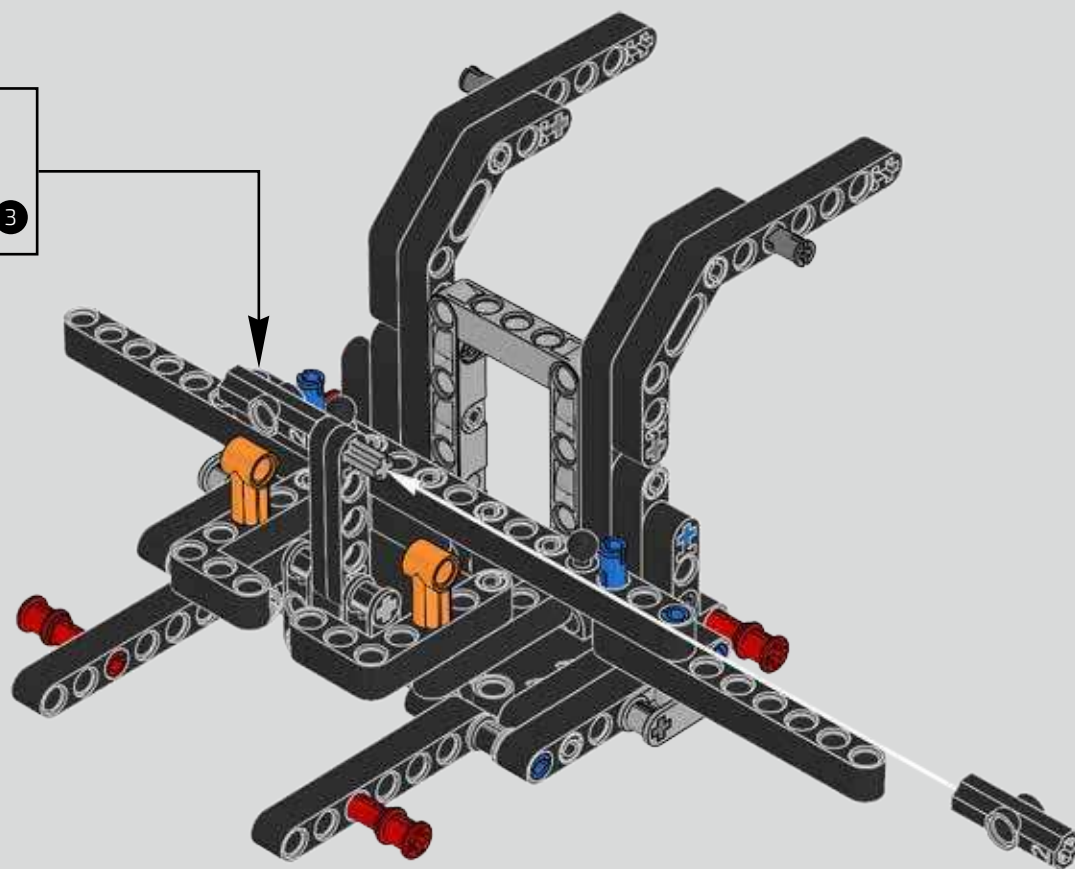
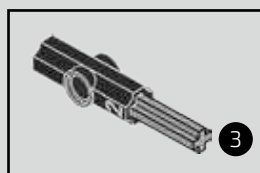

339

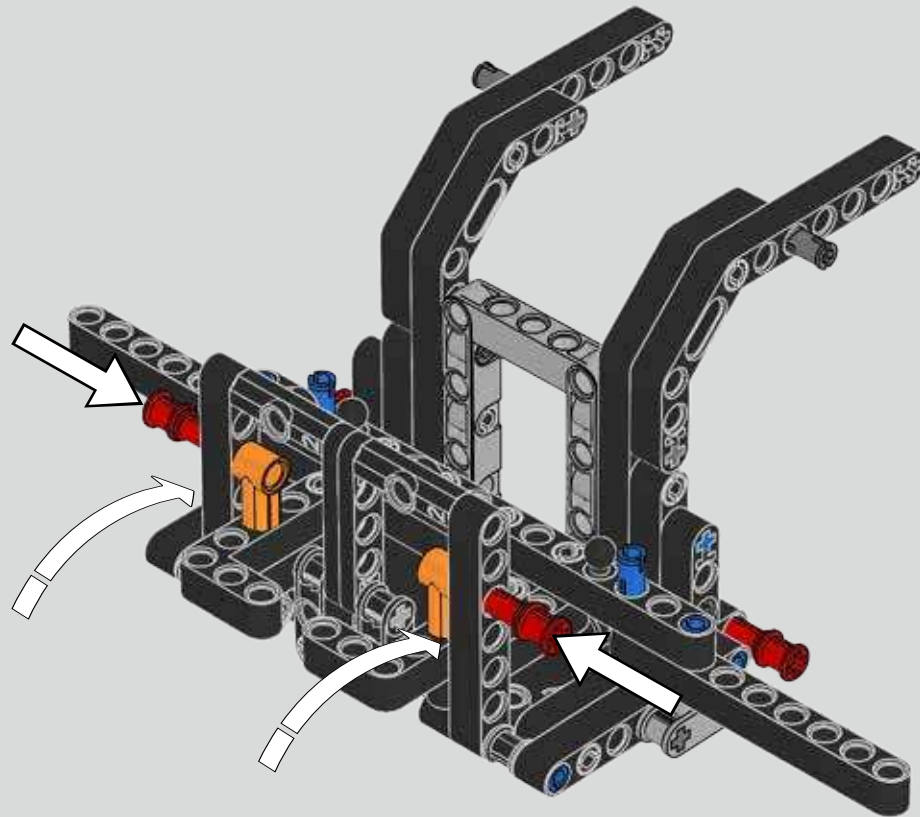



340

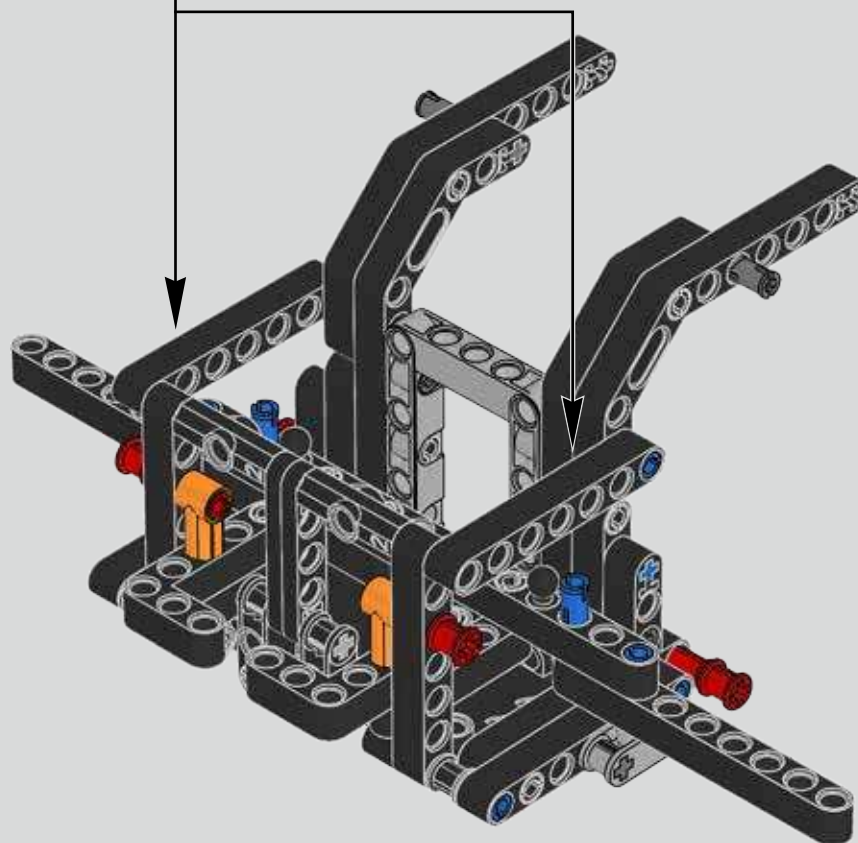
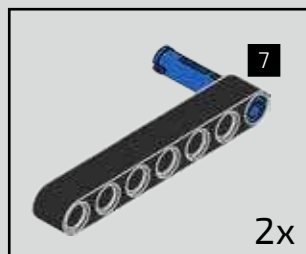

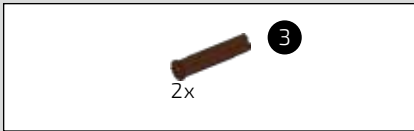

341

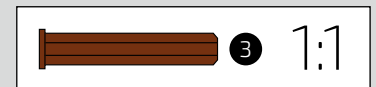
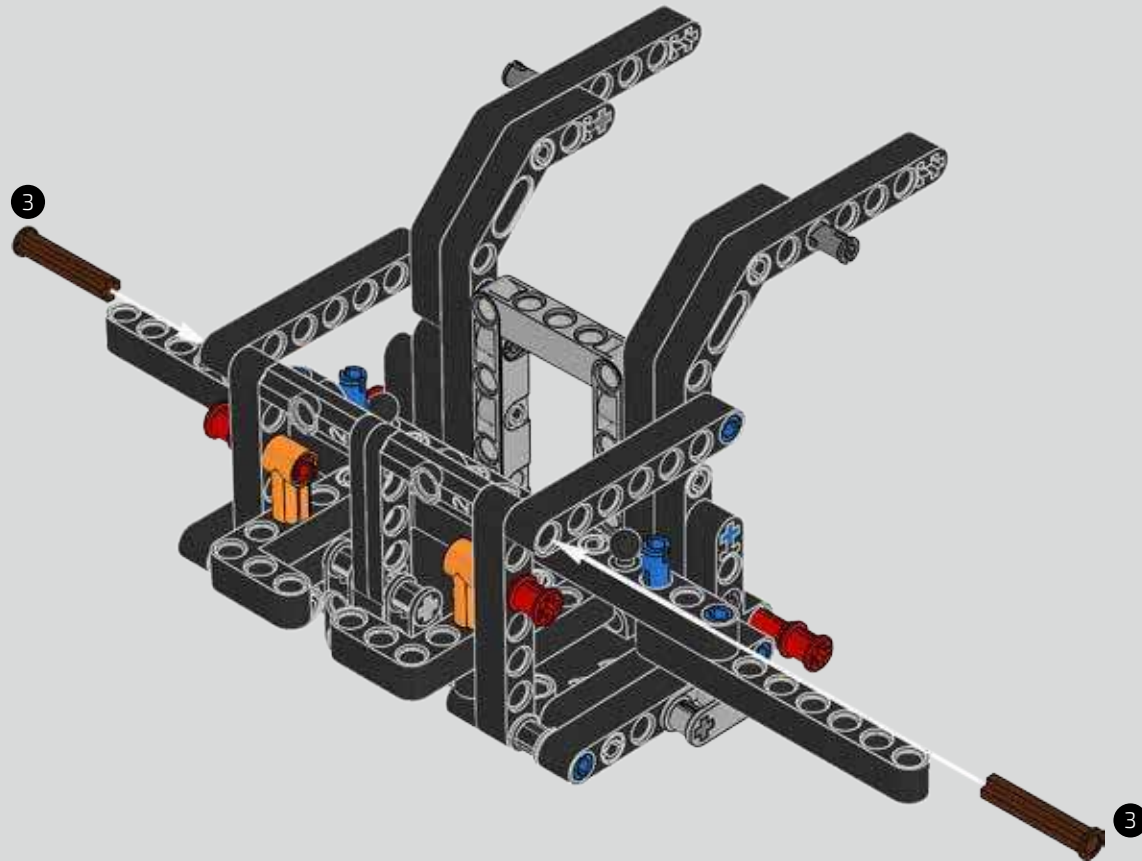

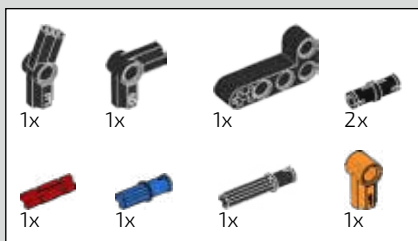

342

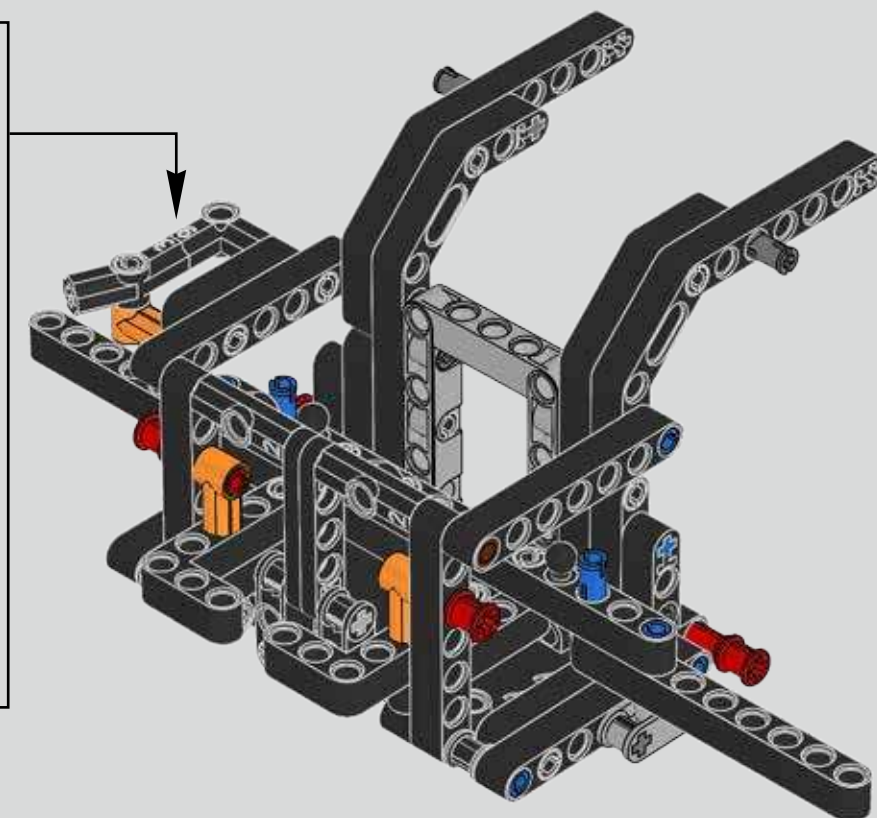
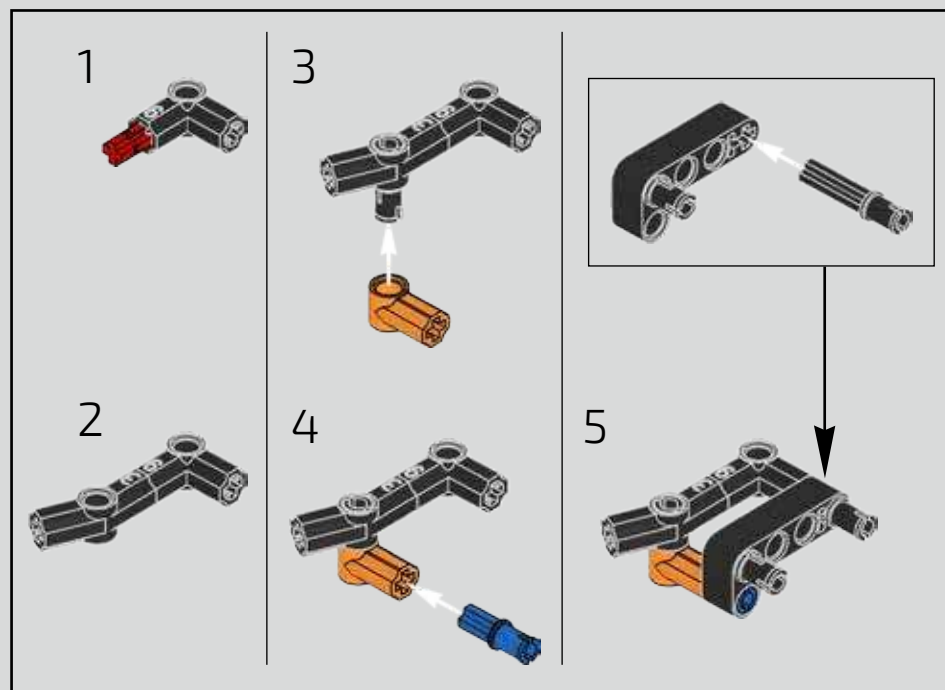

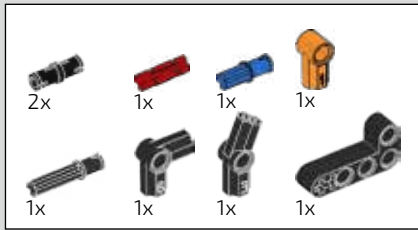

343

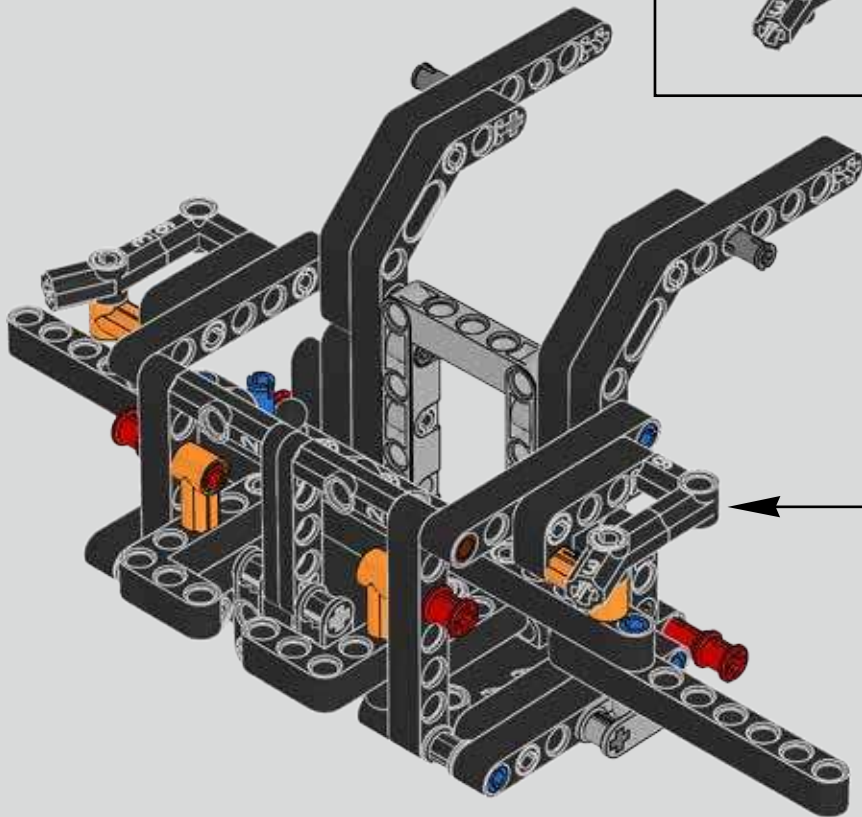
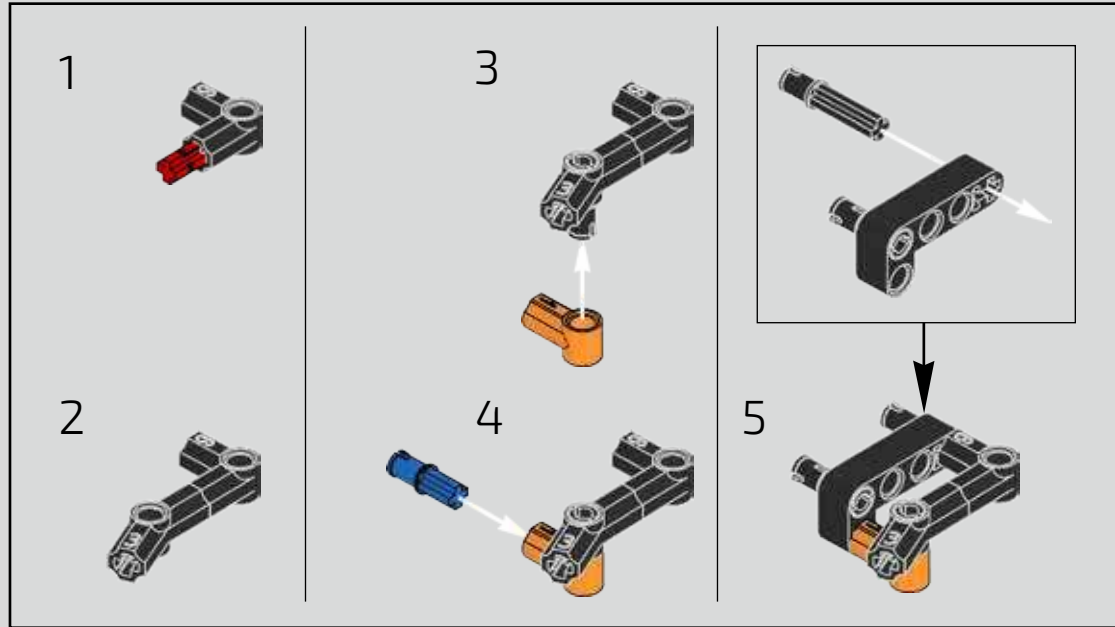

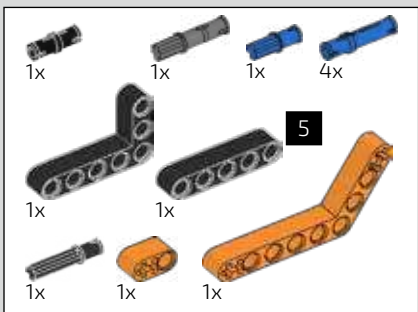

344

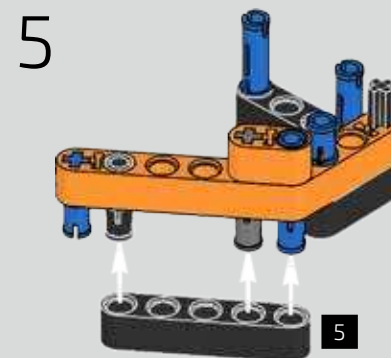
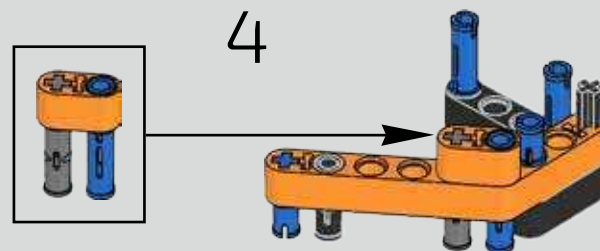
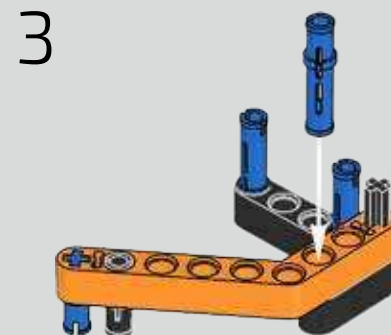
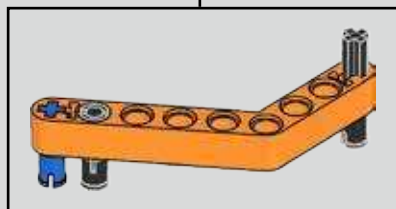
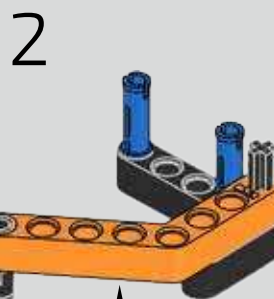
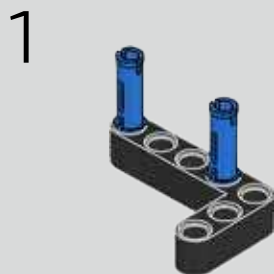

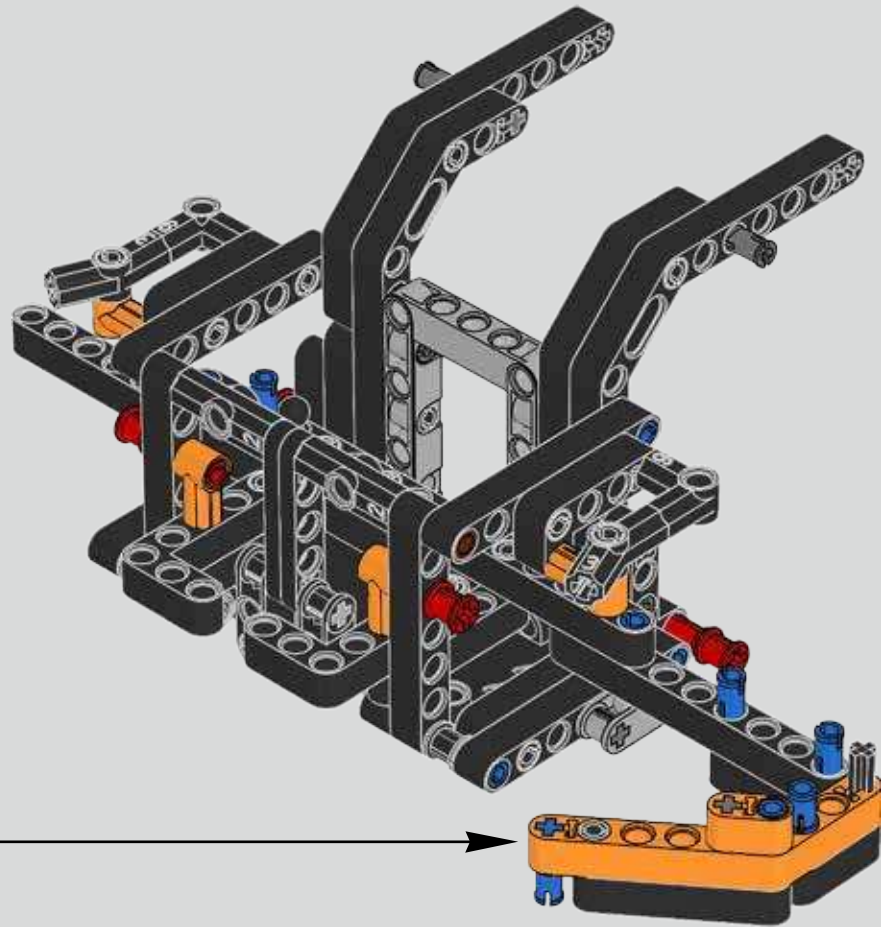

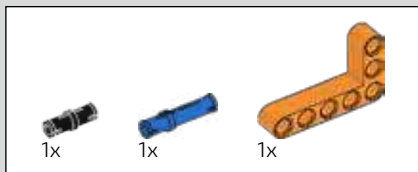

345

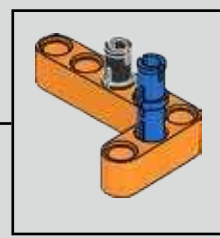
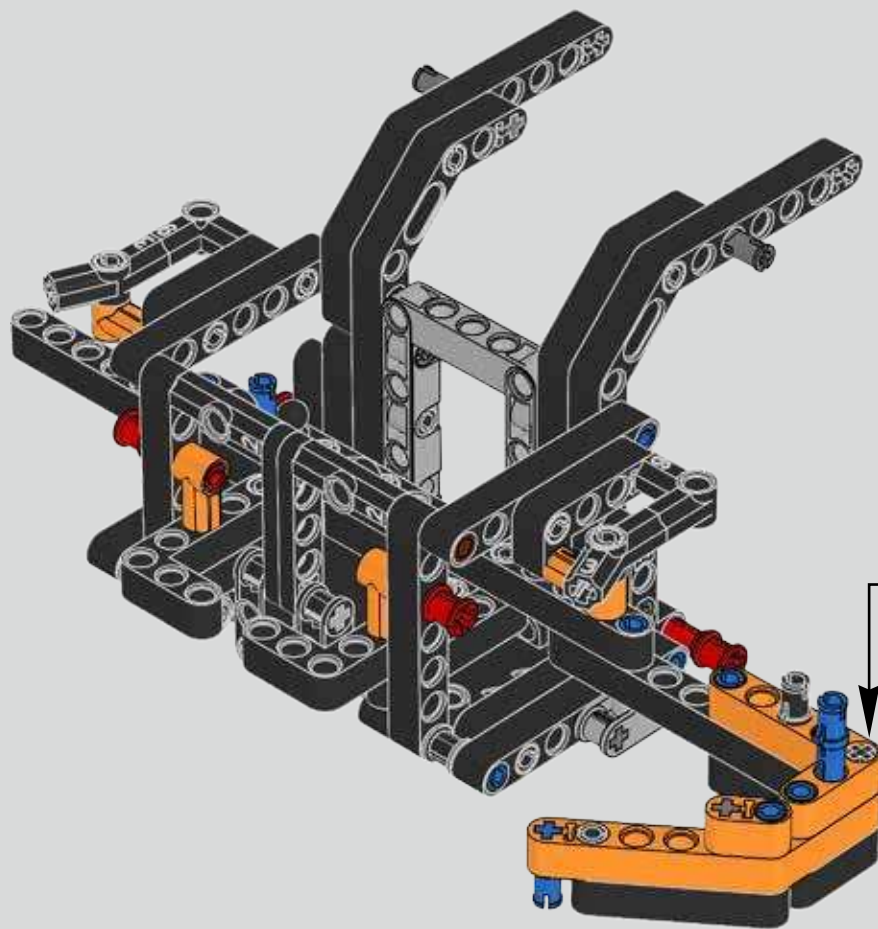

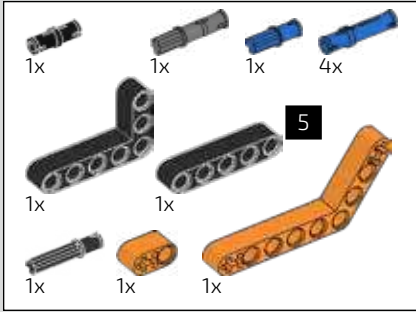
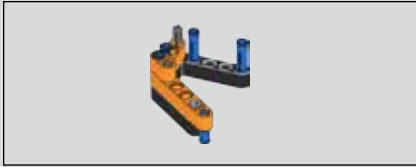

346

1

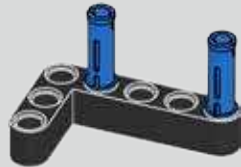

2

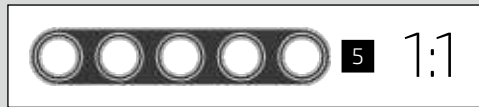
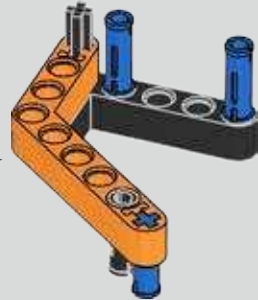
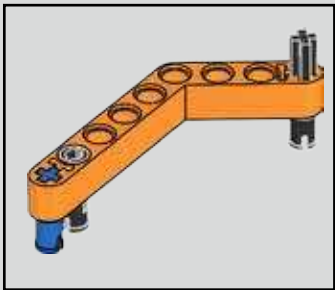

3

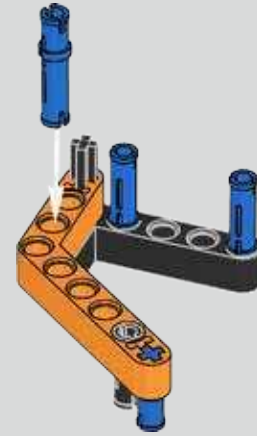

4

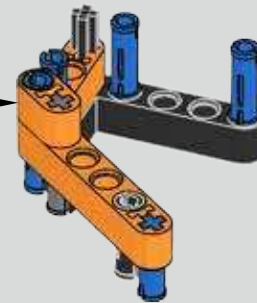
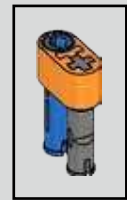

5

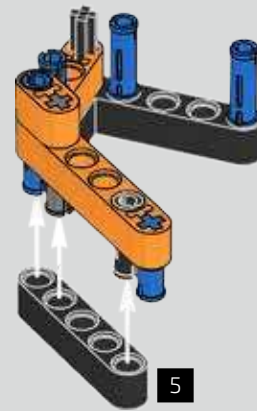

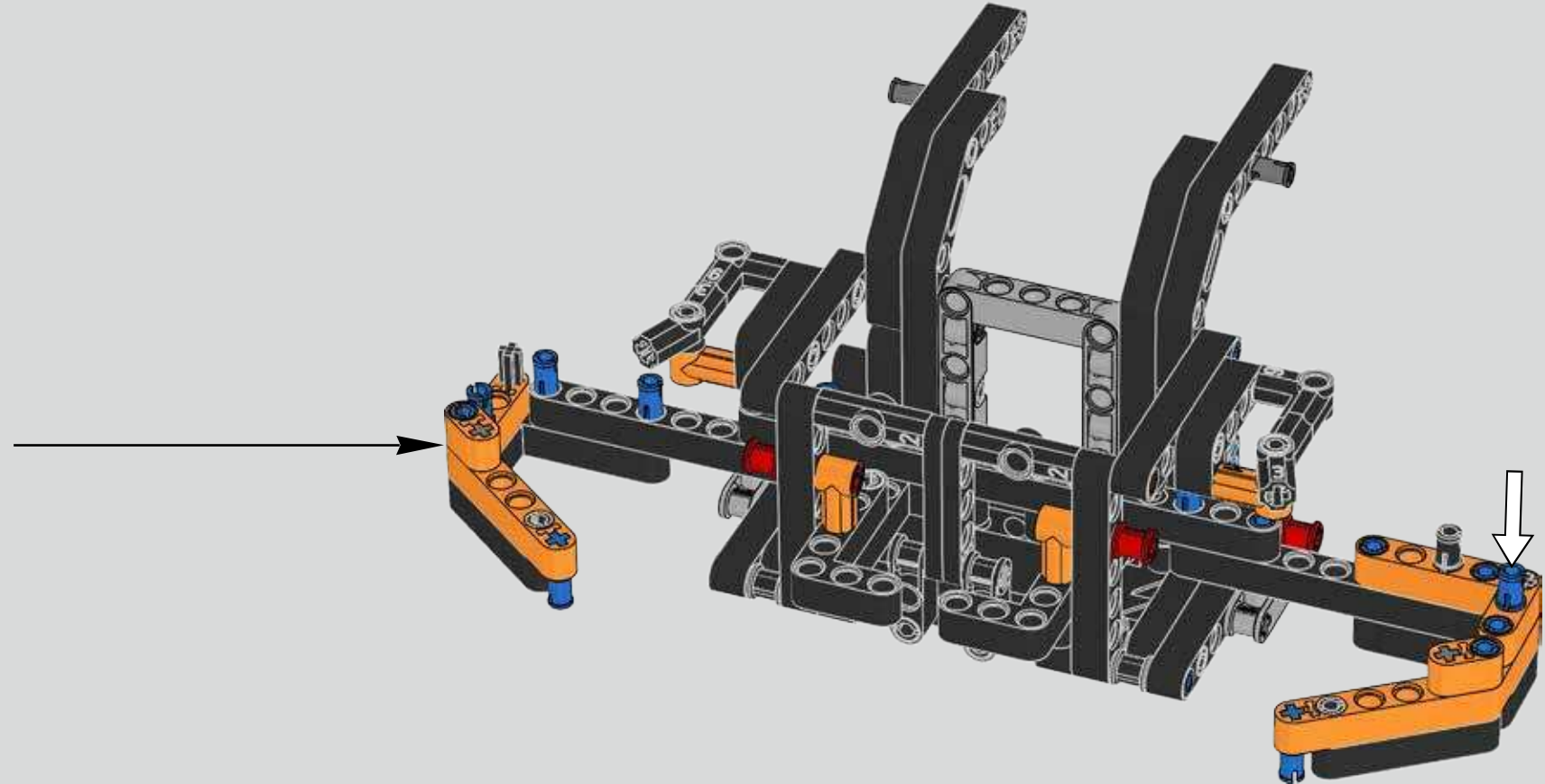

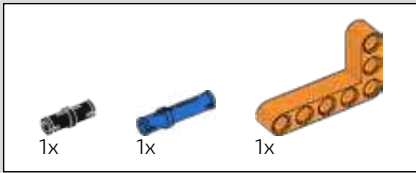

347

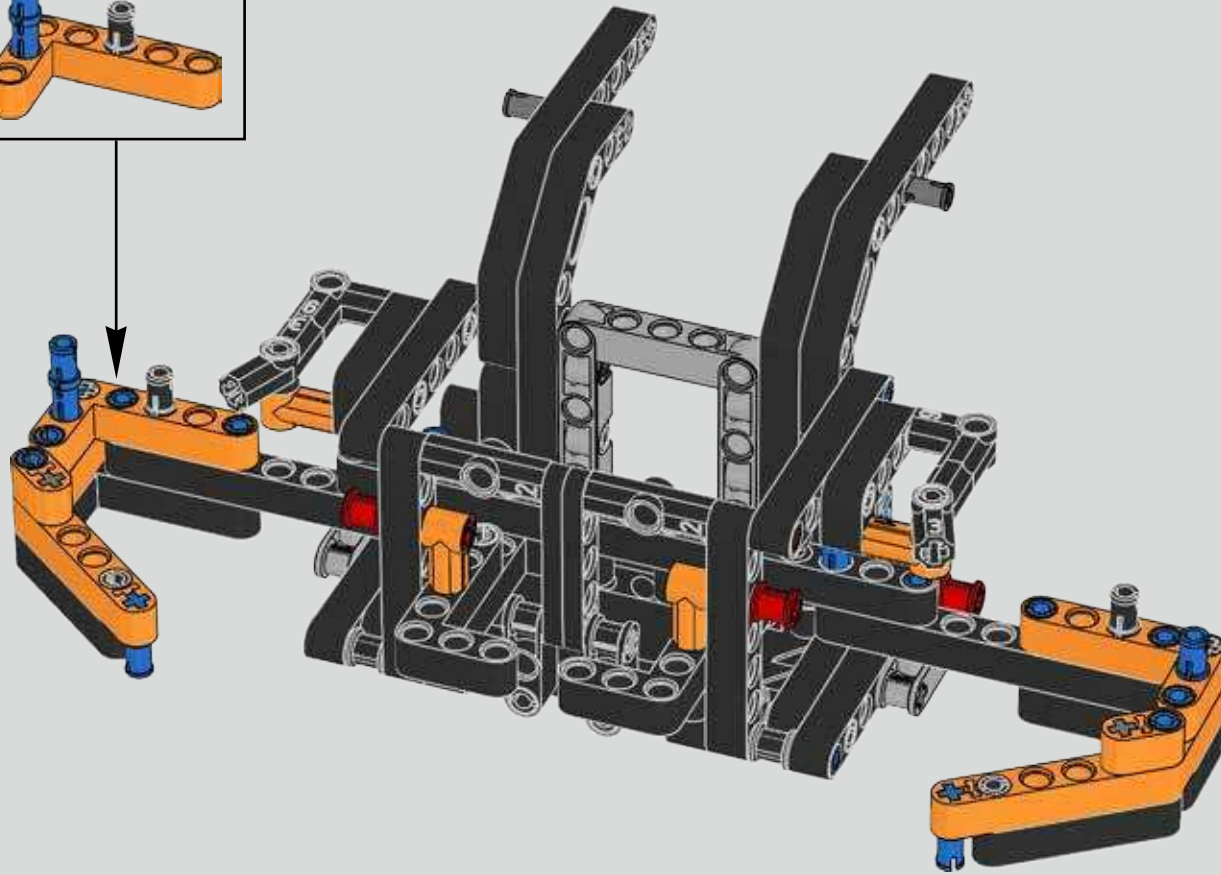
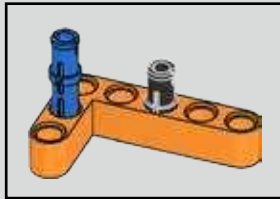

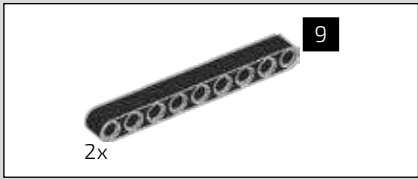

348

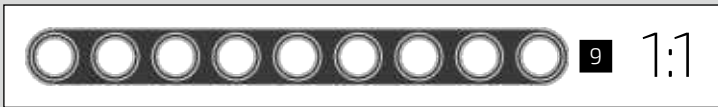
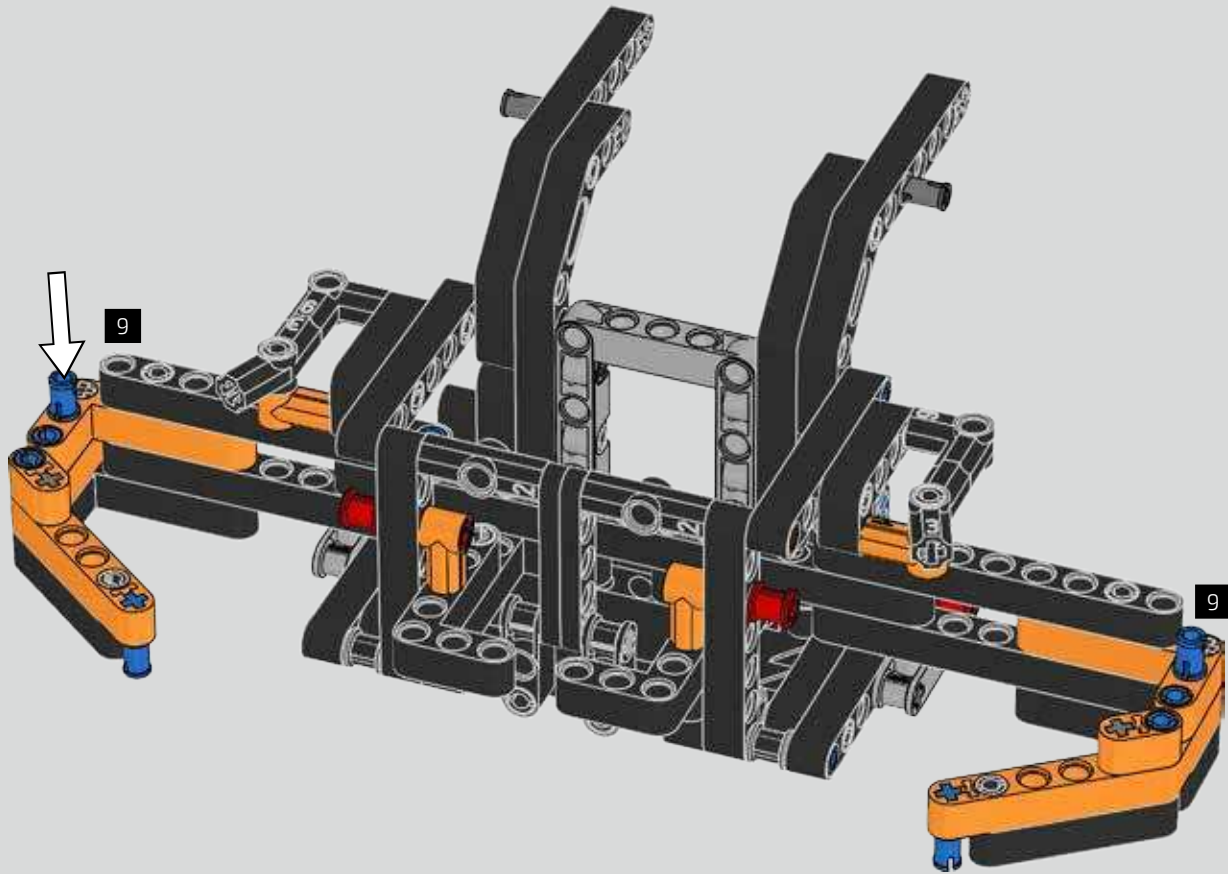

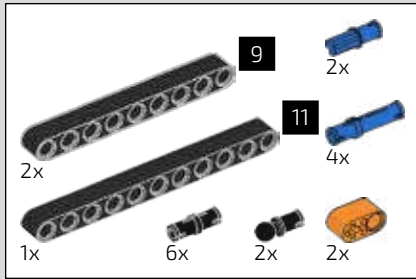

349

1

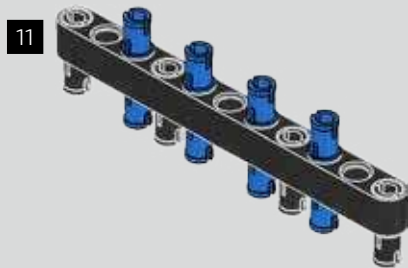

2

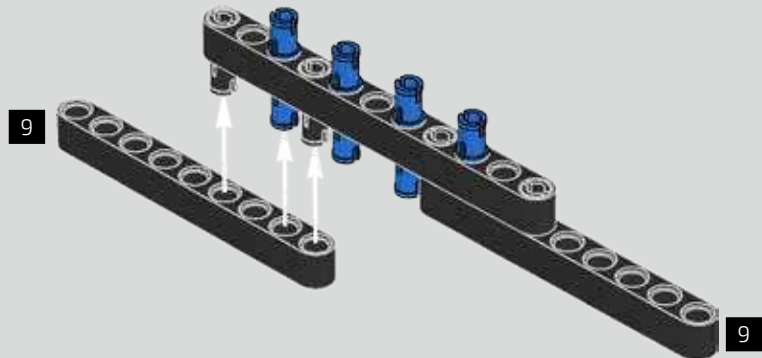

3

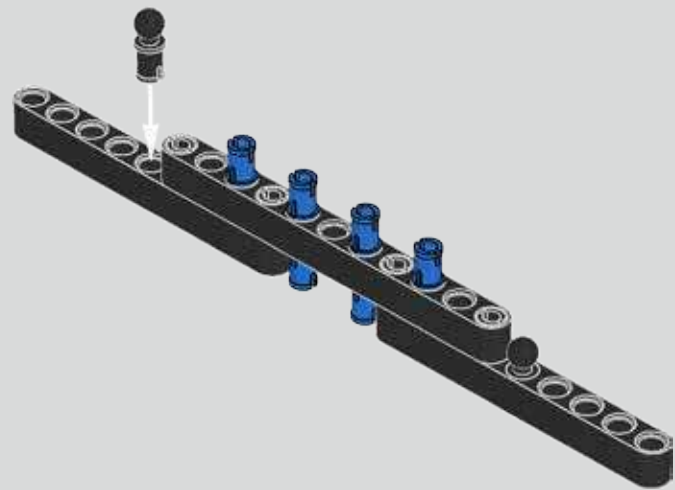

4

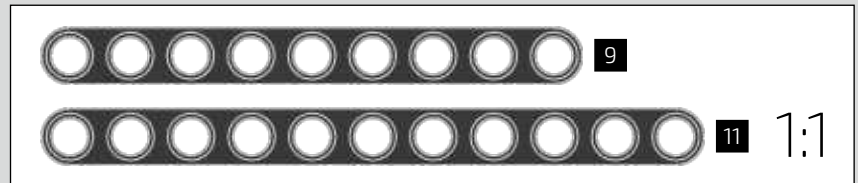
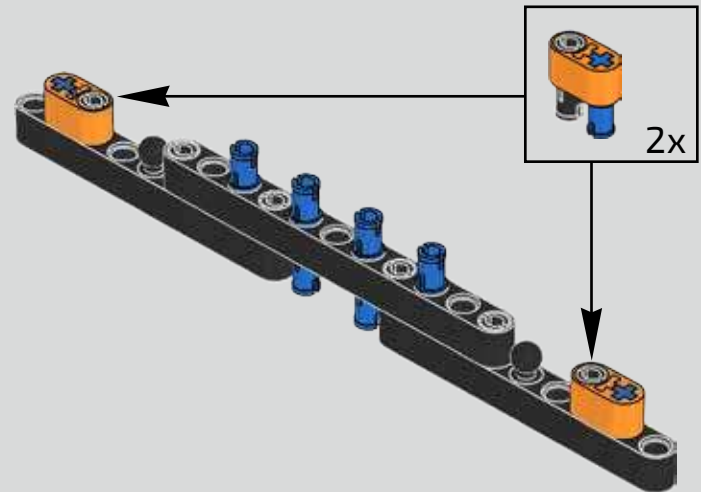

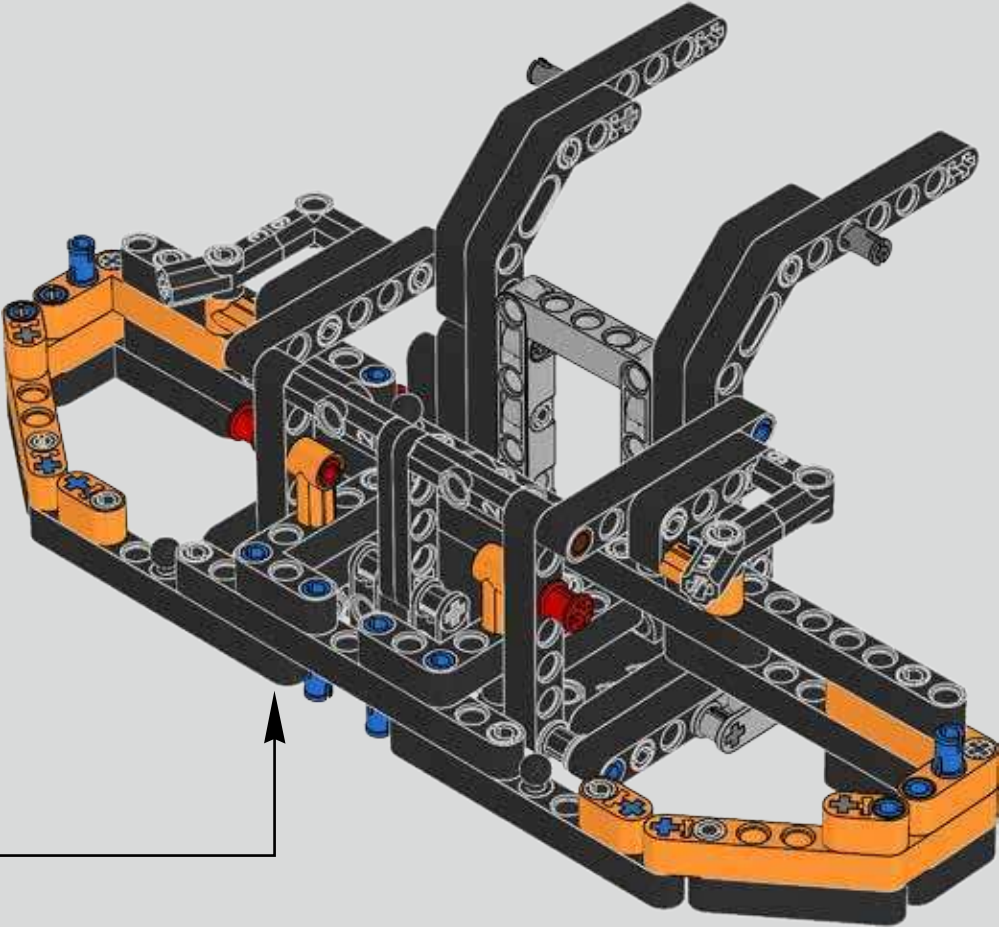

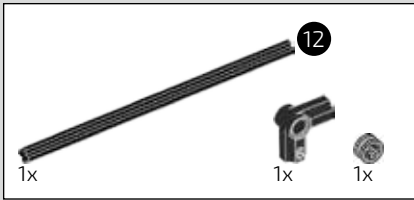

350

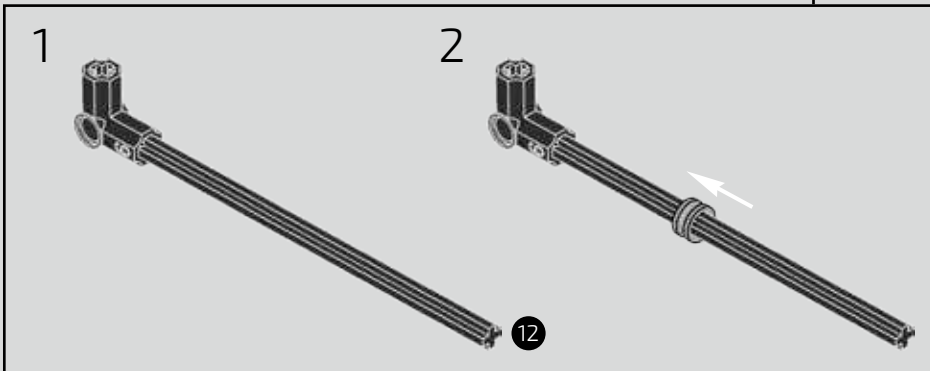
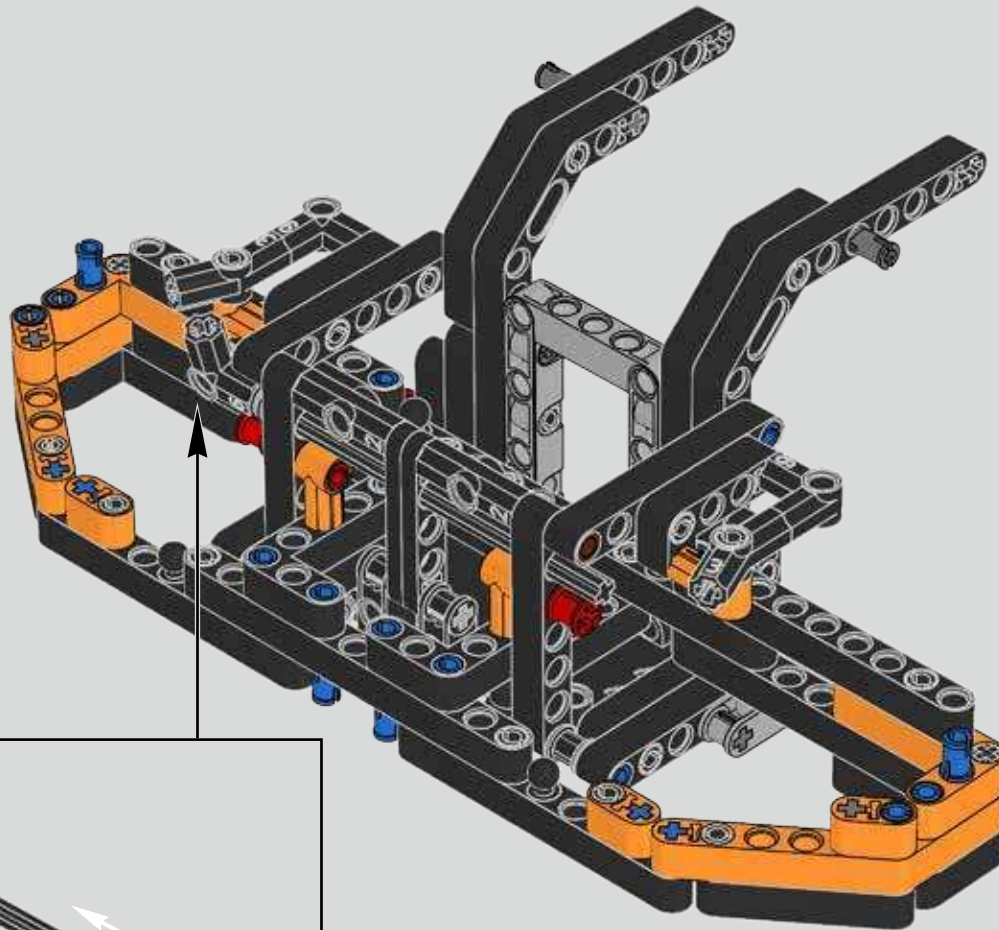



351

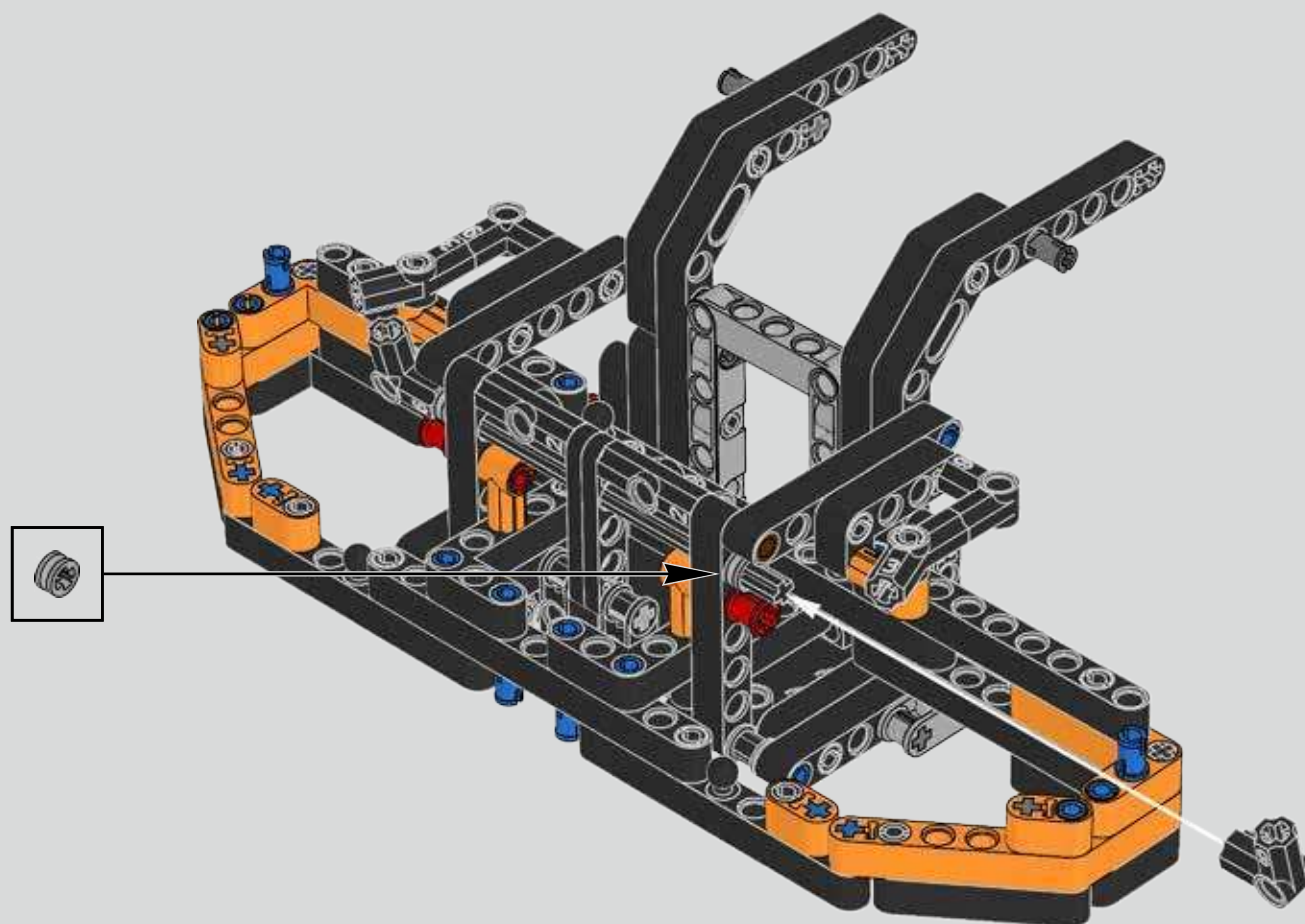

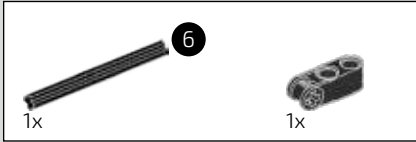
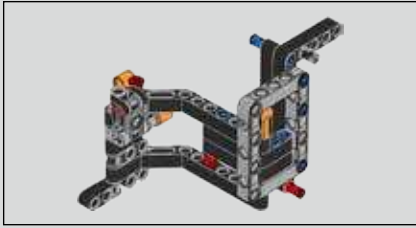

352



353

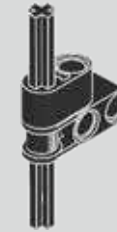

354



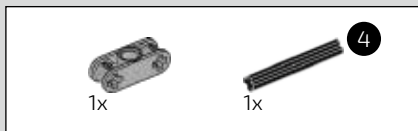

355

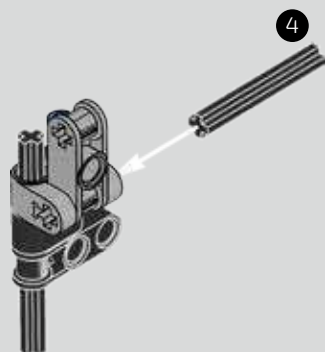

356

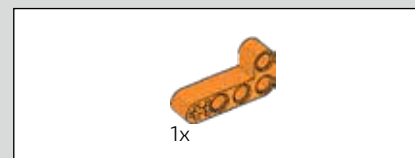
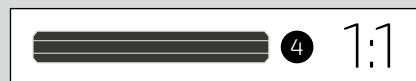
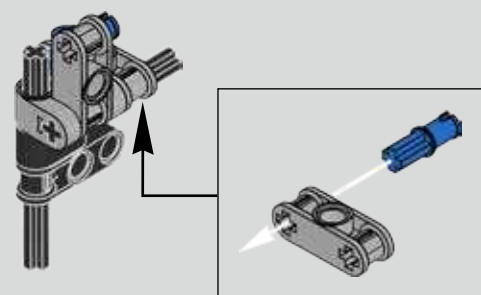

357

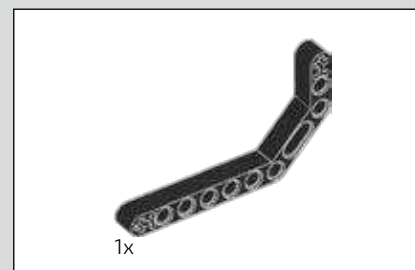
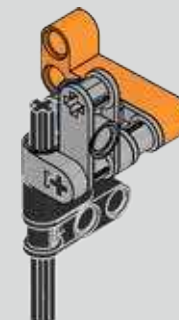

358

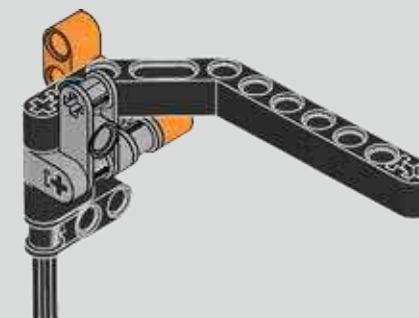

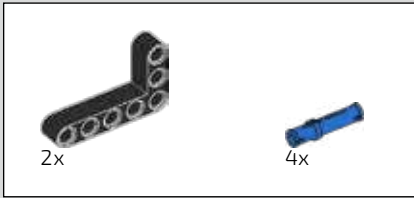

359

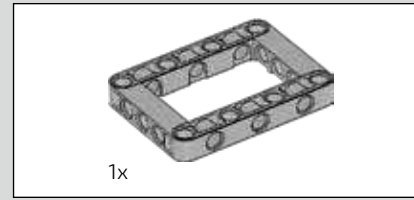
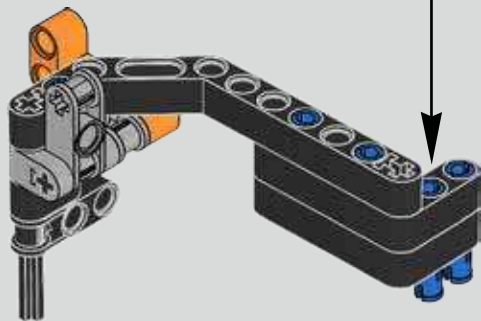
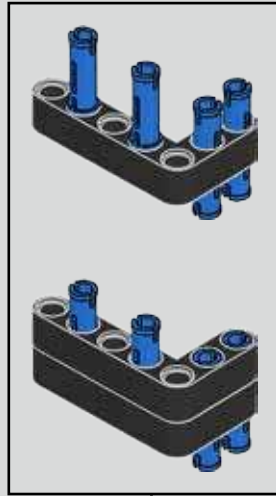

360

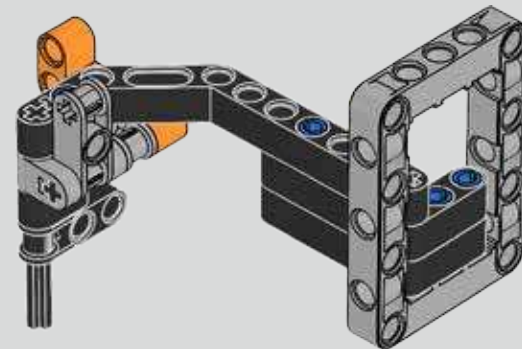

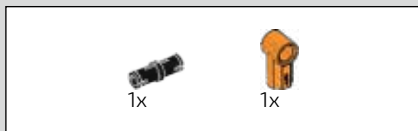

361

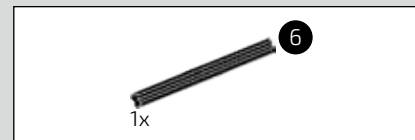
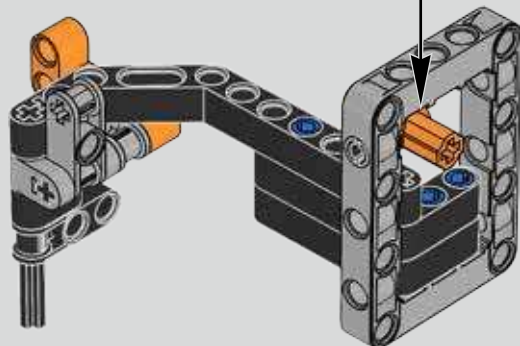
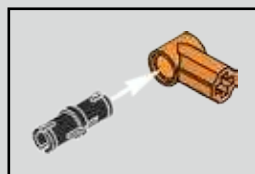

362

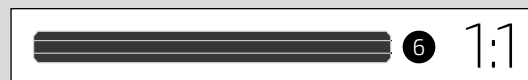
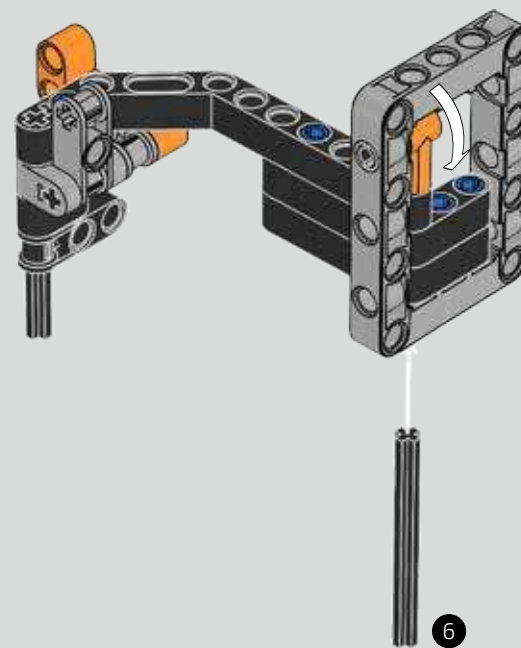

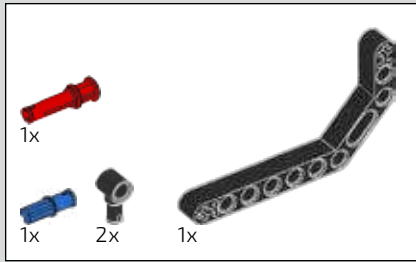

363

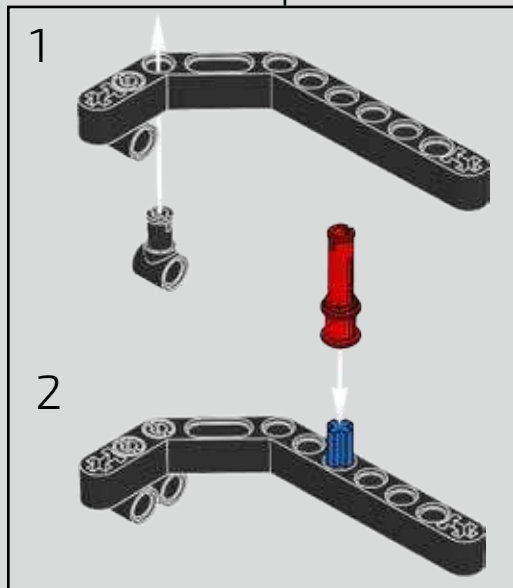
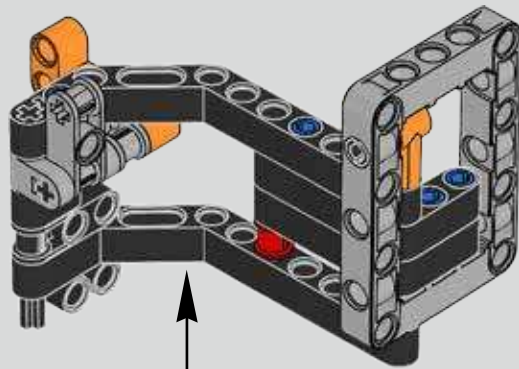

364

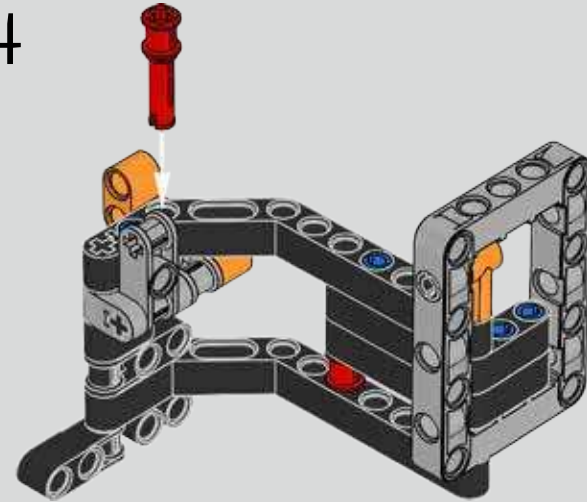

365

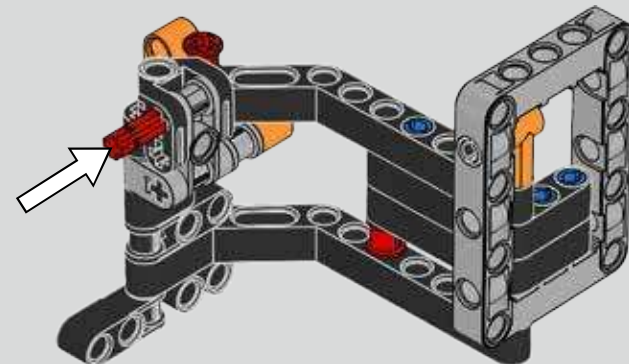

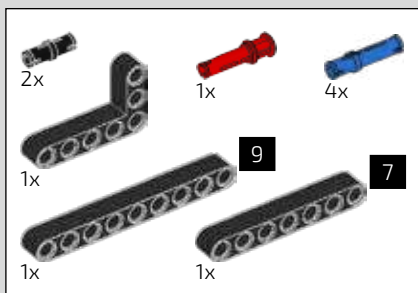

366

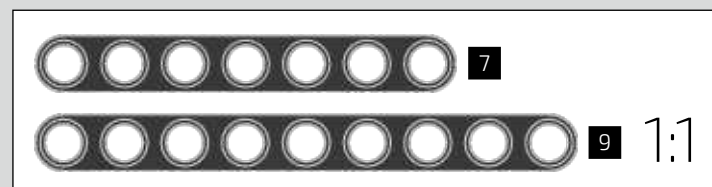
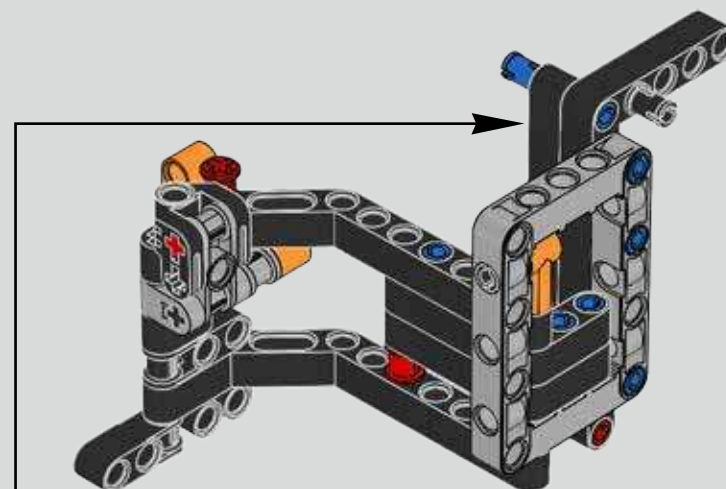
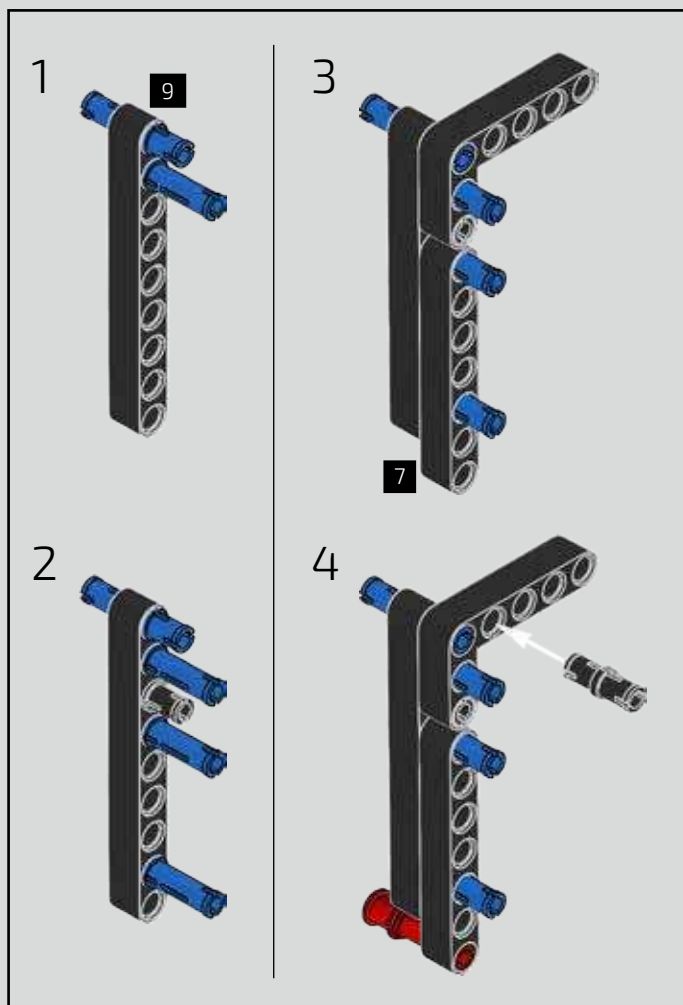

367

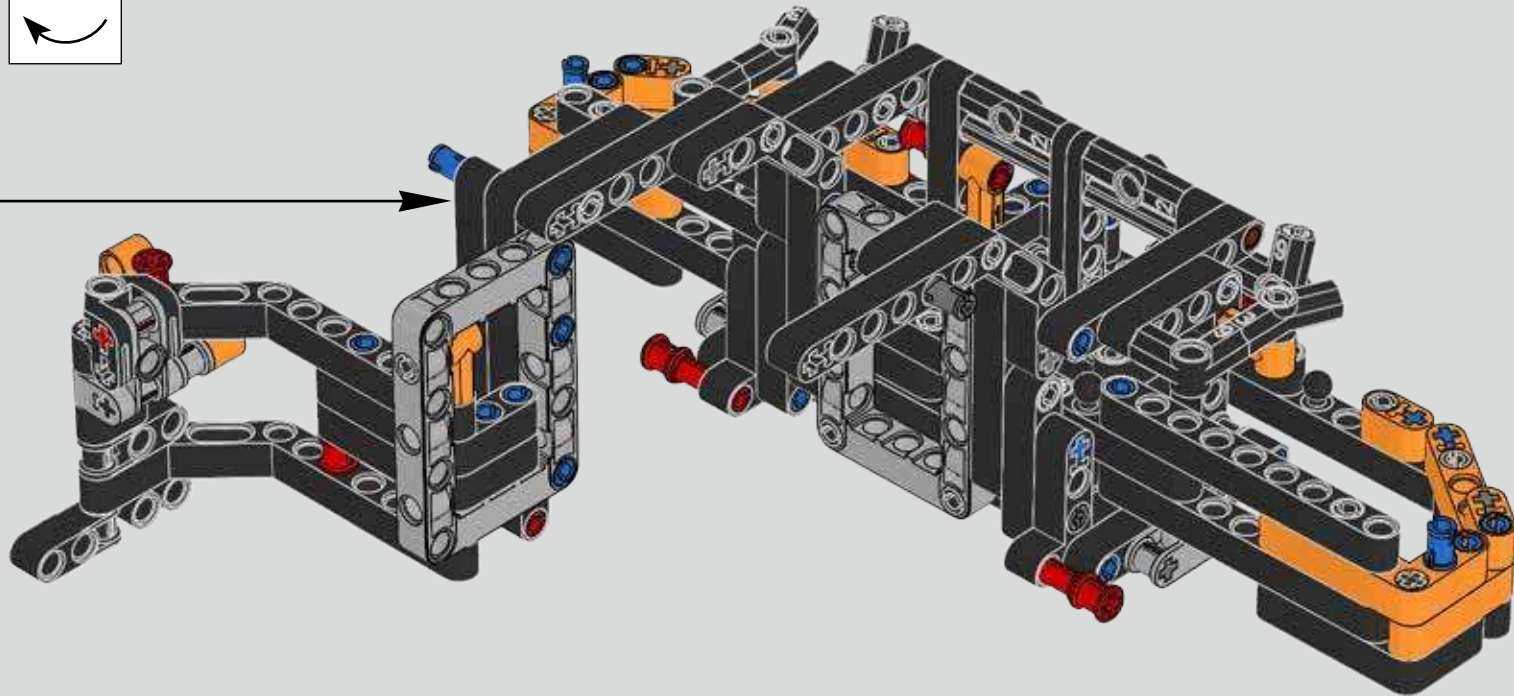
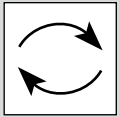

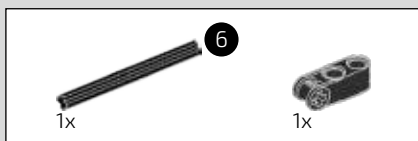
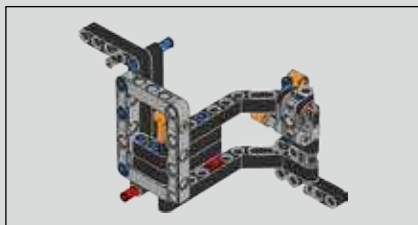

368

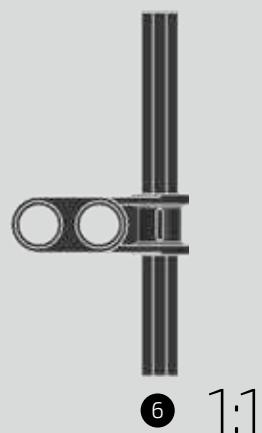

369

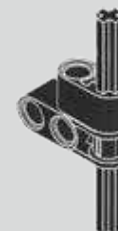

370



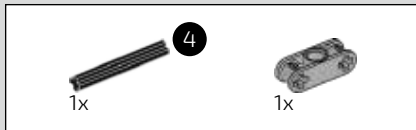

371

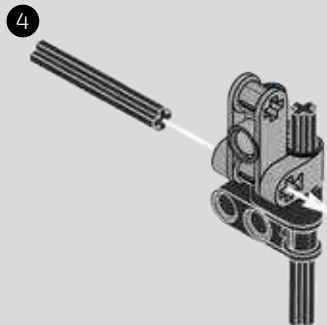

372

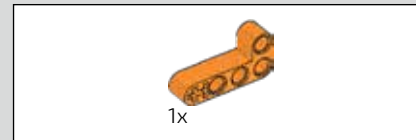
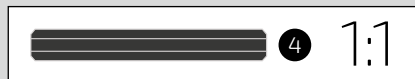
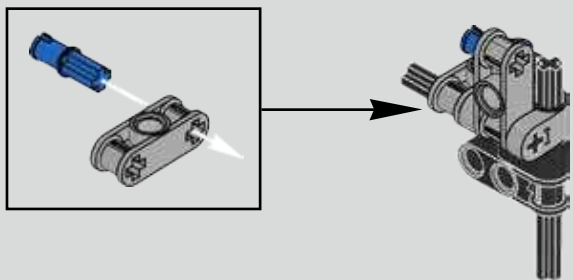

373

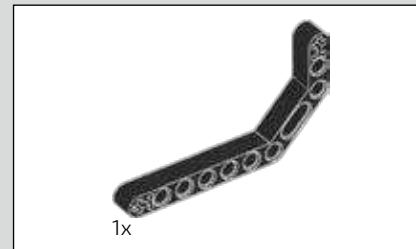
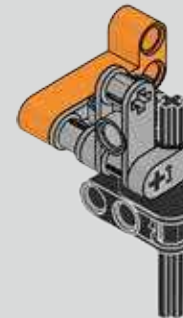

374

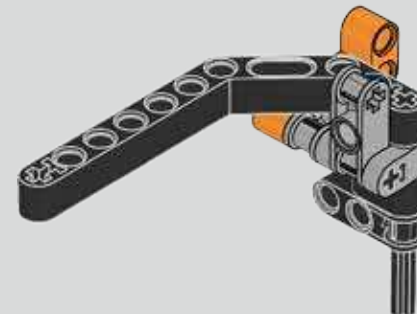

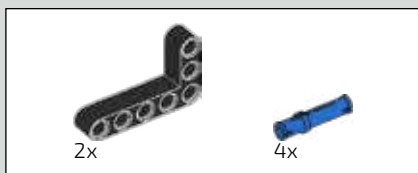

375

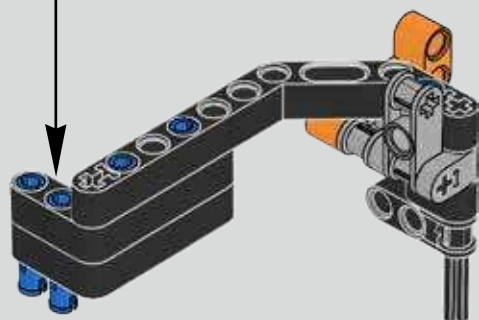
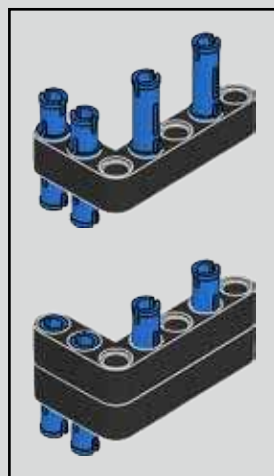

376

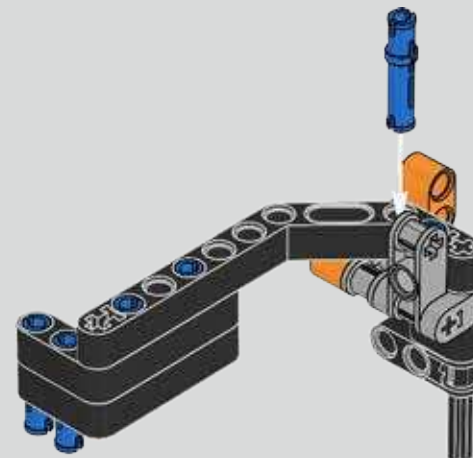

377

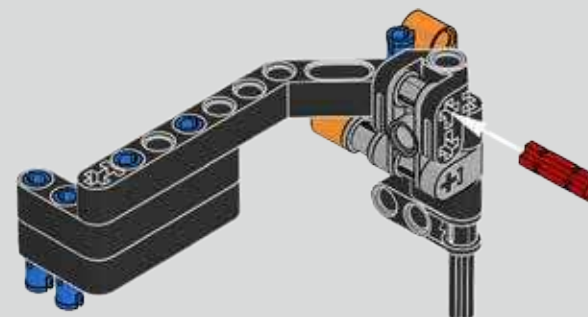

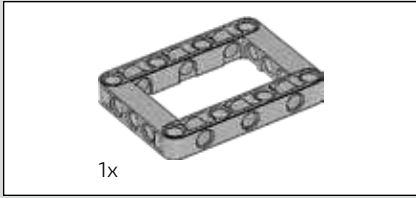

378

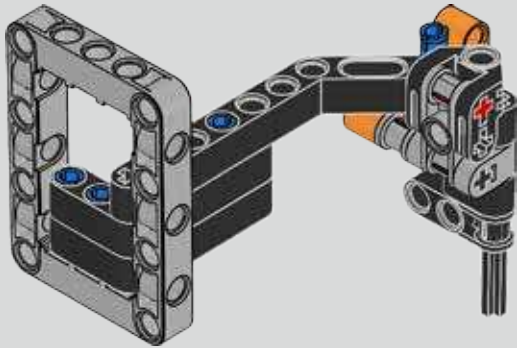

379

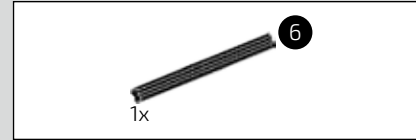
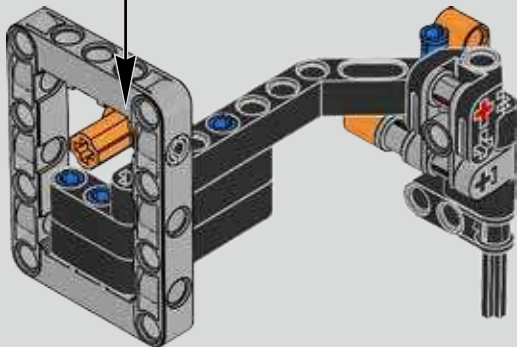
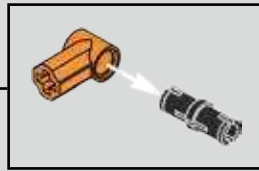

380

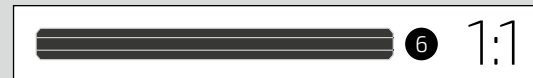
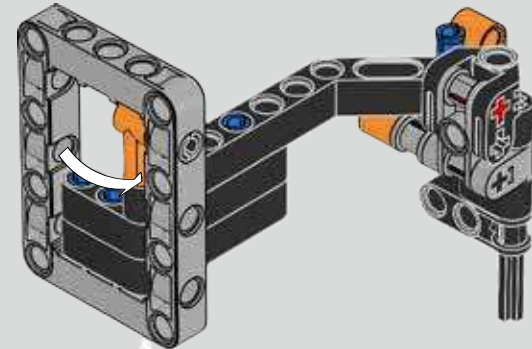

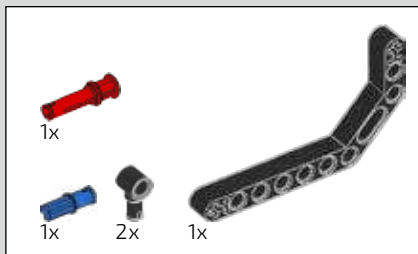

381

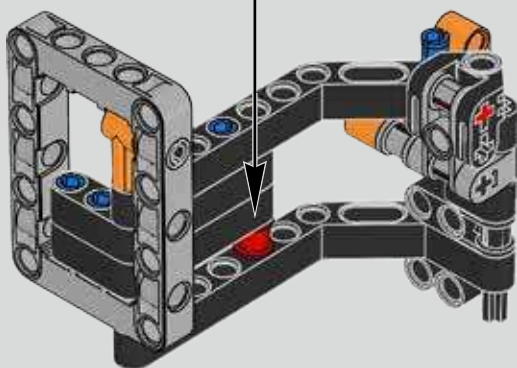
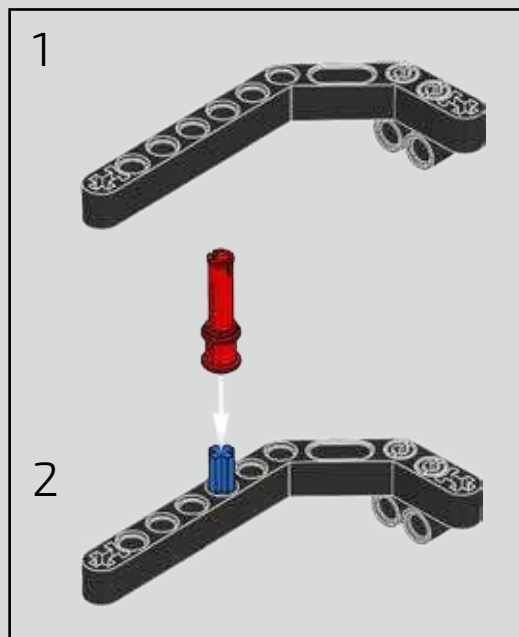

382

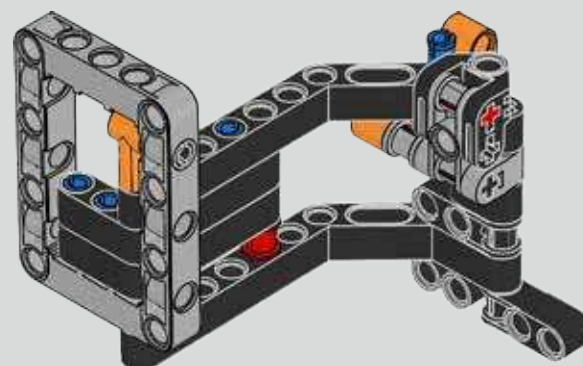

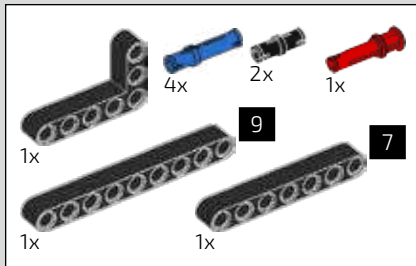

383

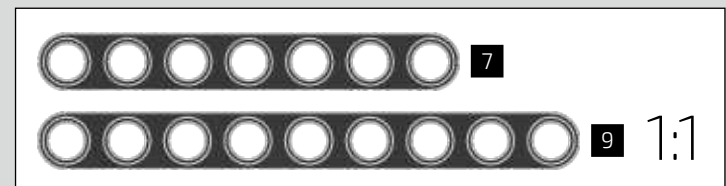
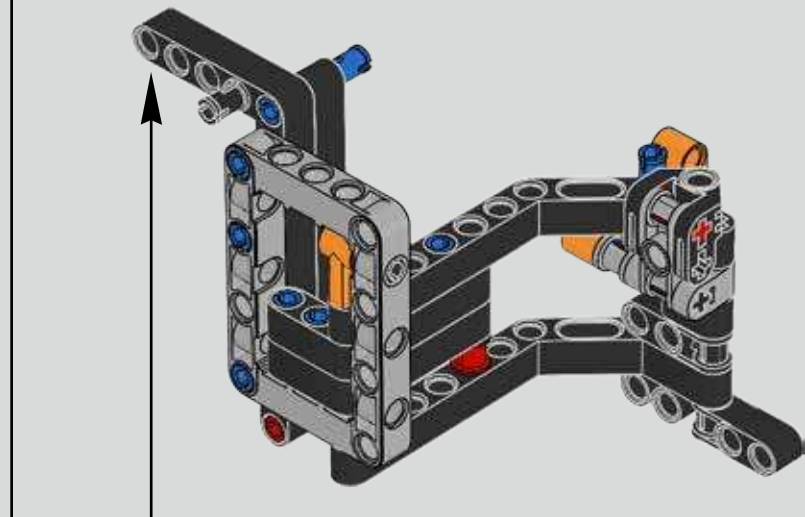
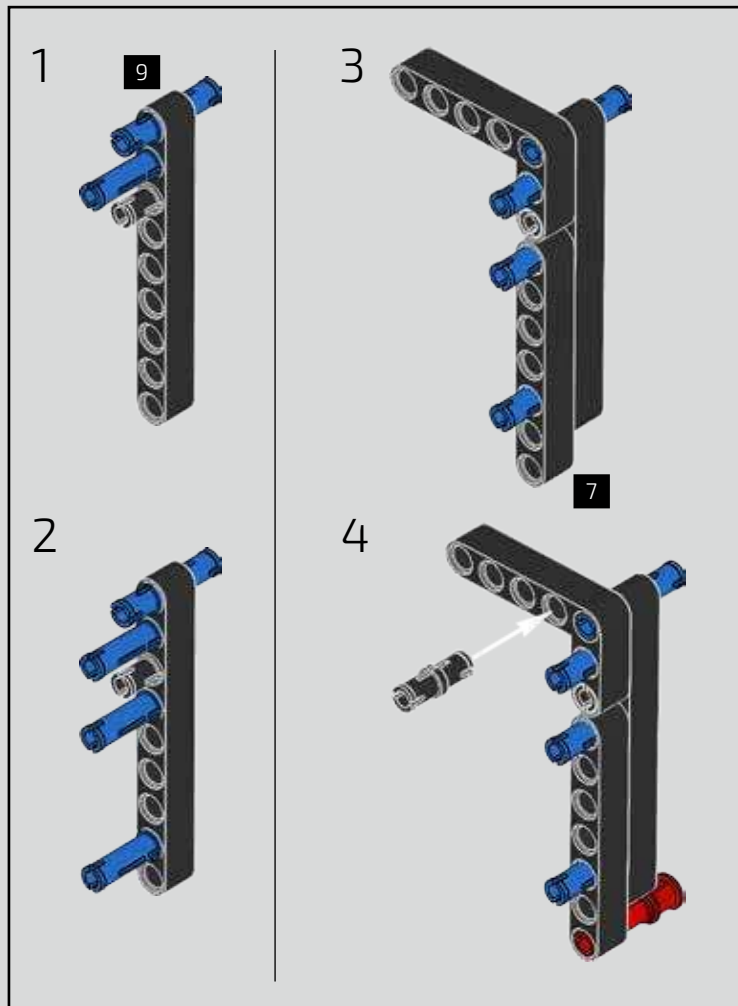

384

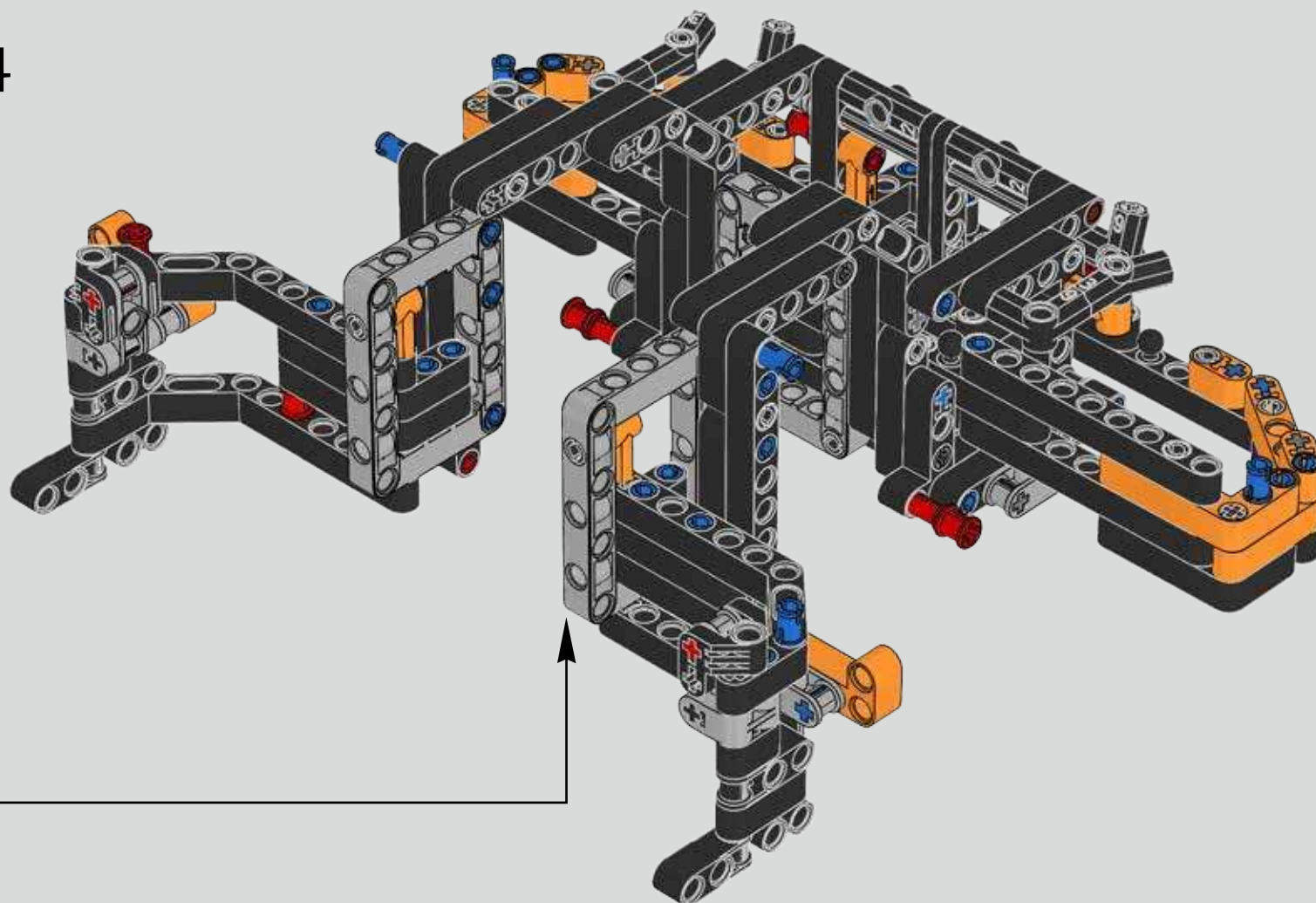



385

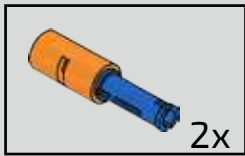
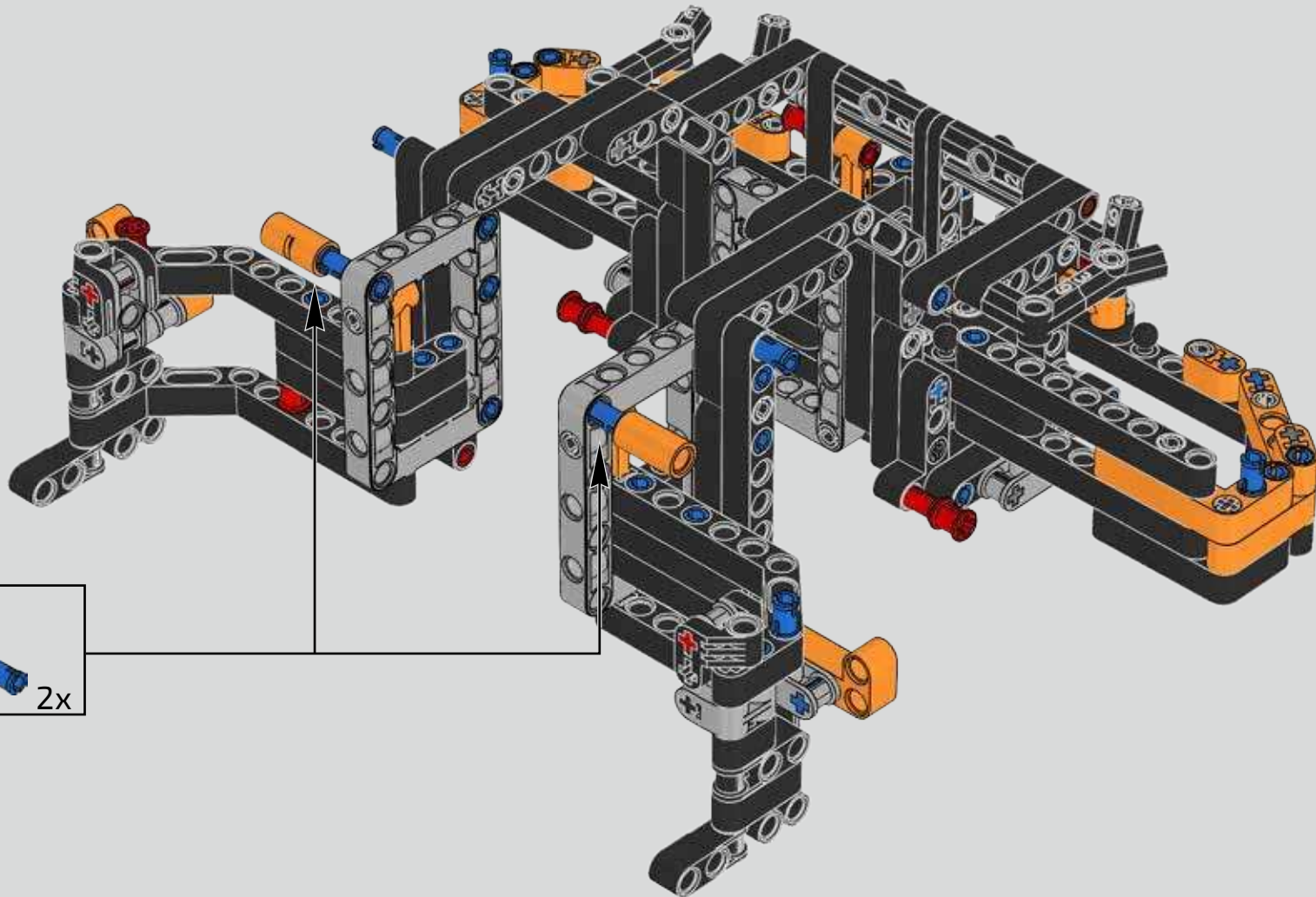

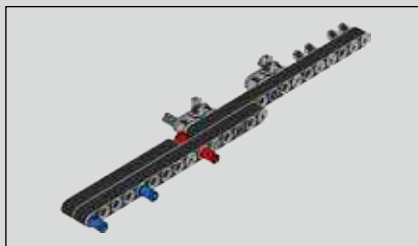

386

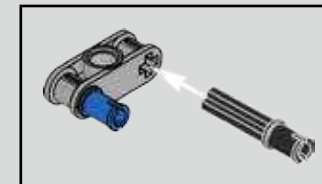
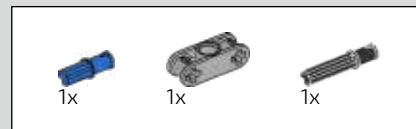
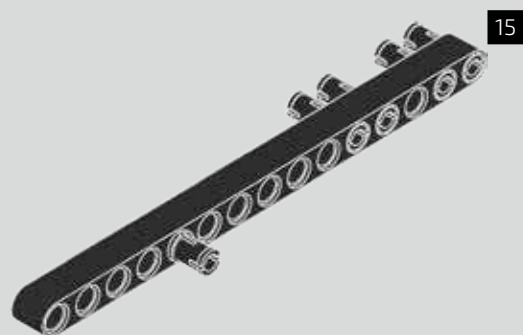

387

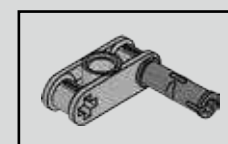
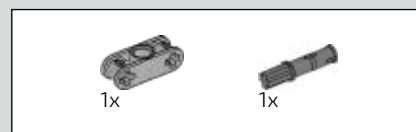
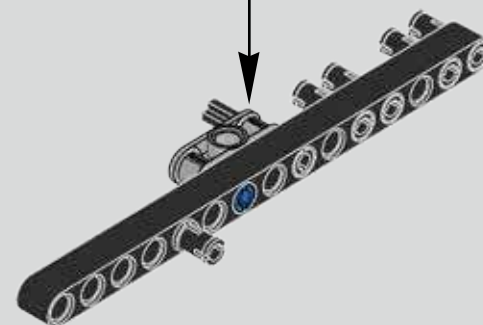

388

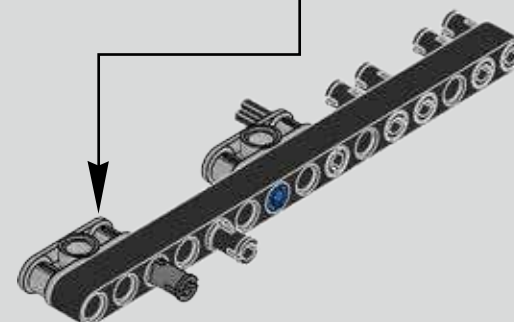

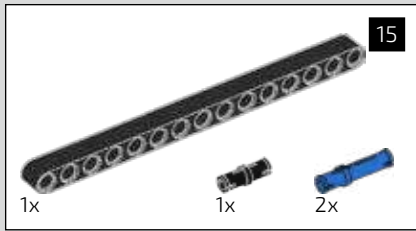

389

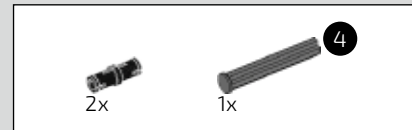
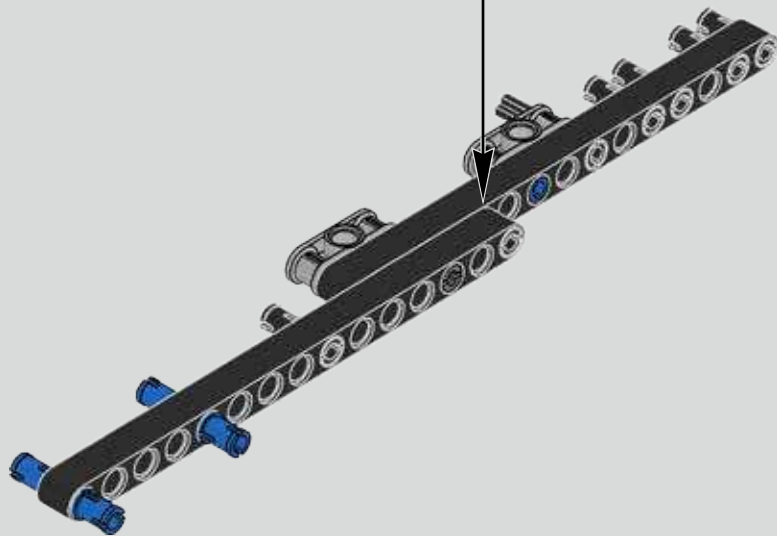
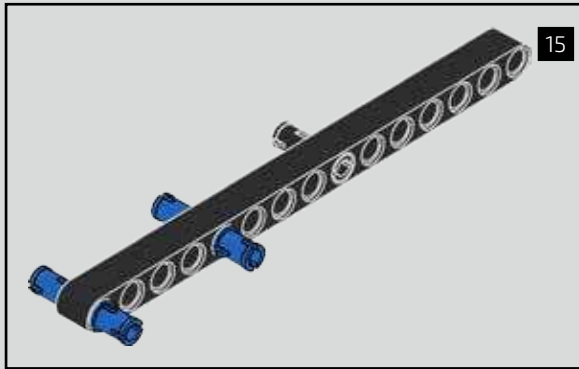

390

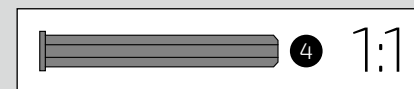
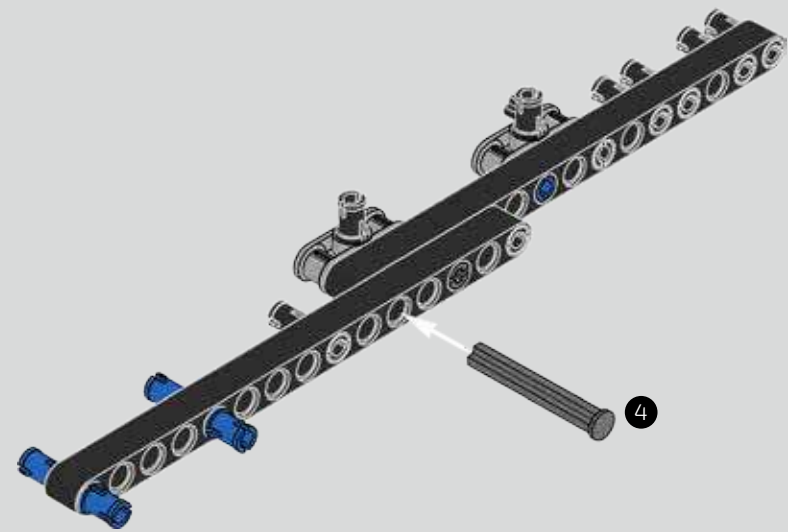

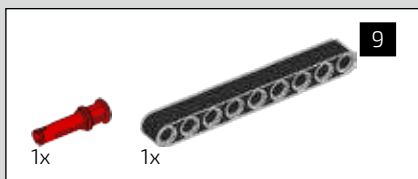

391

9

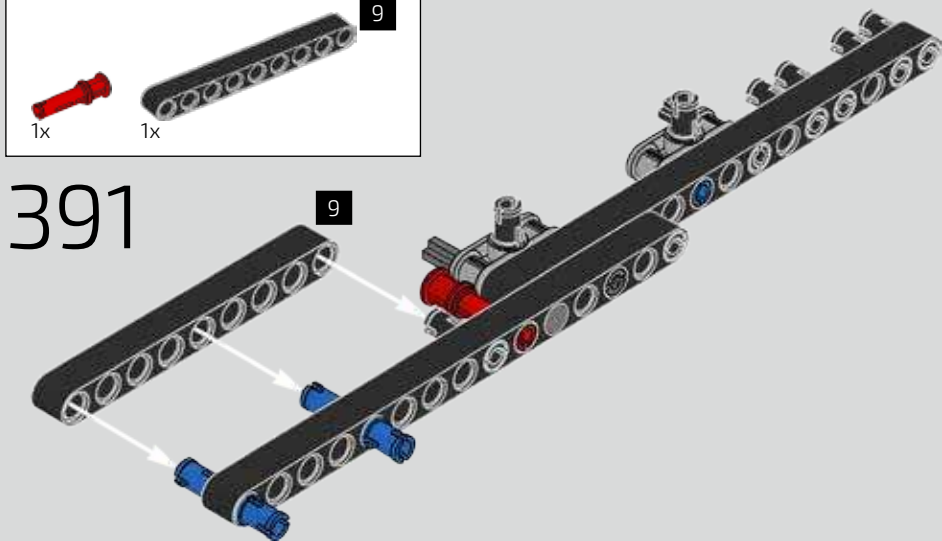

392

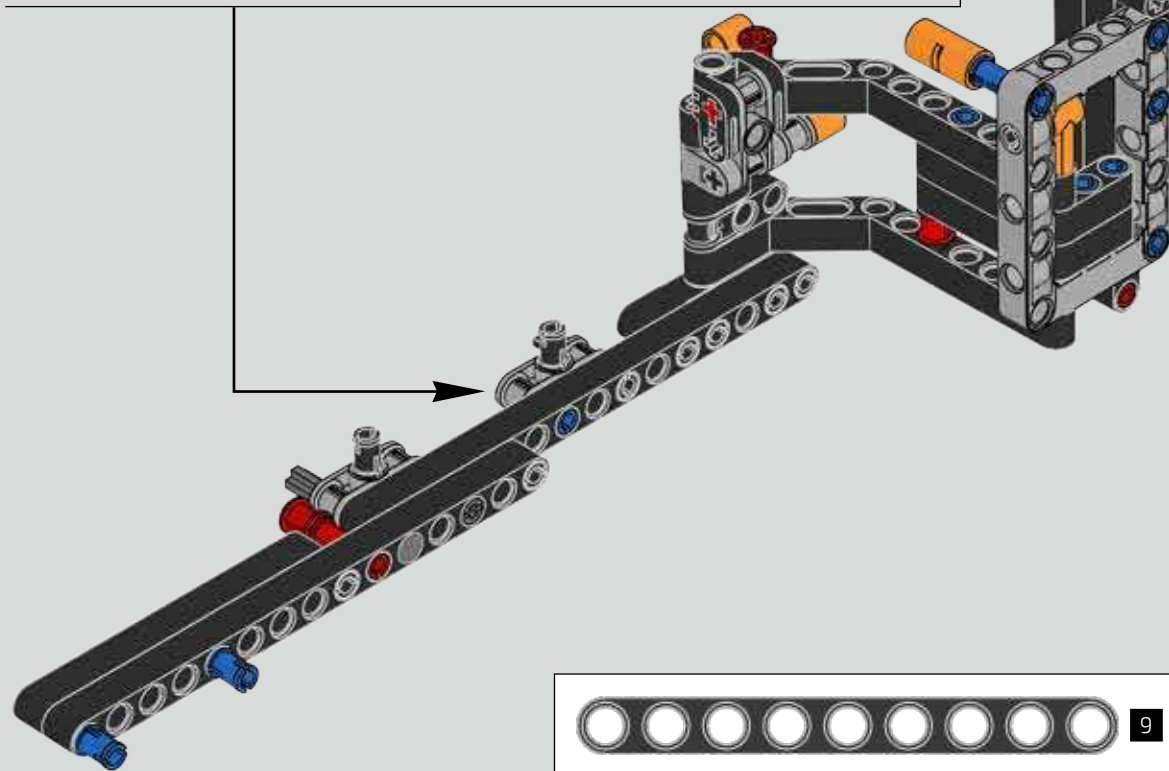
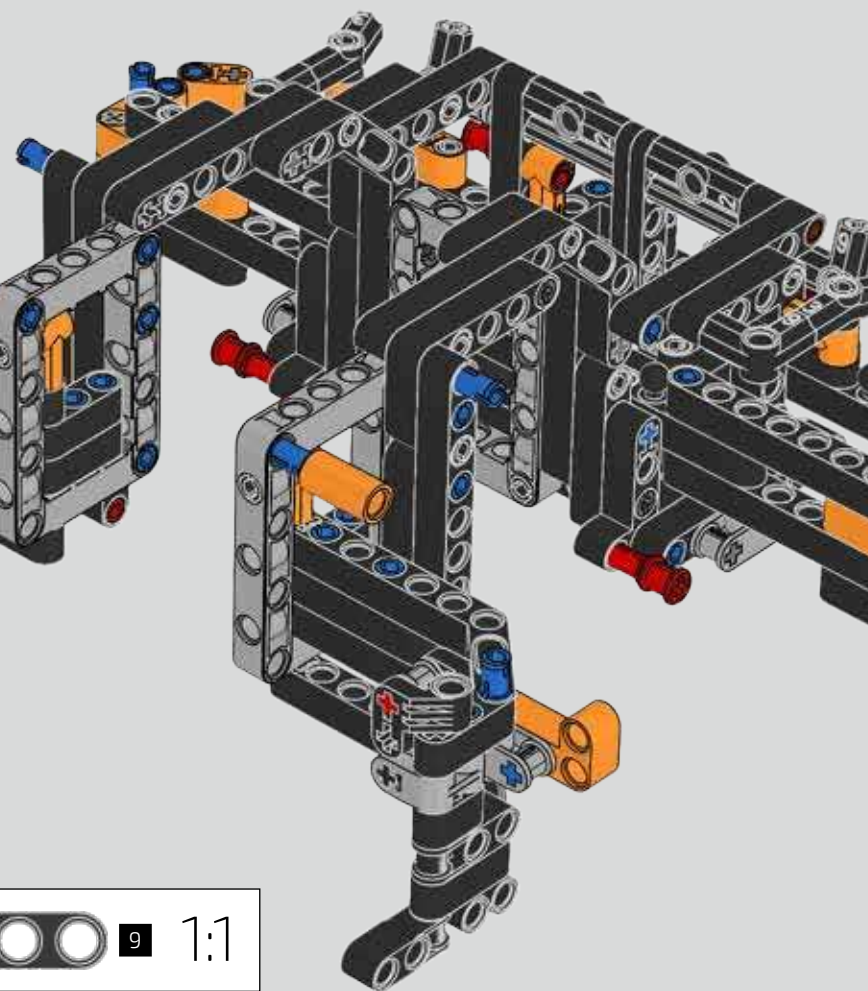

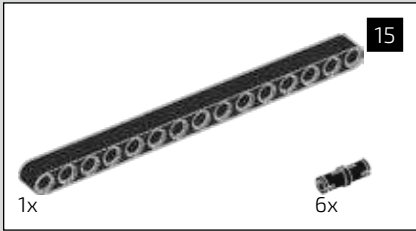
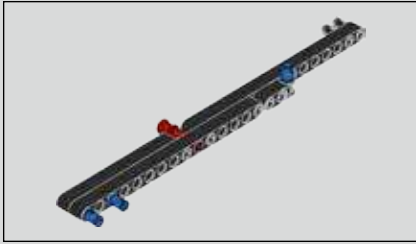

393

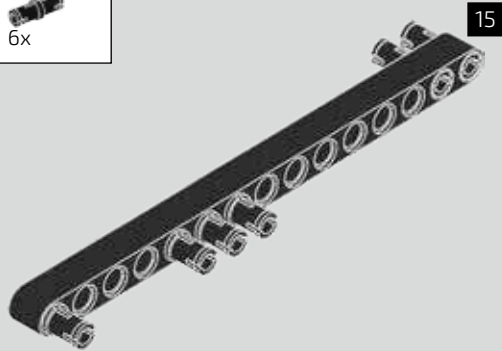

394

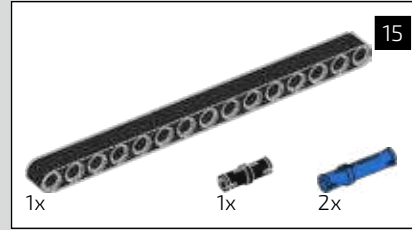
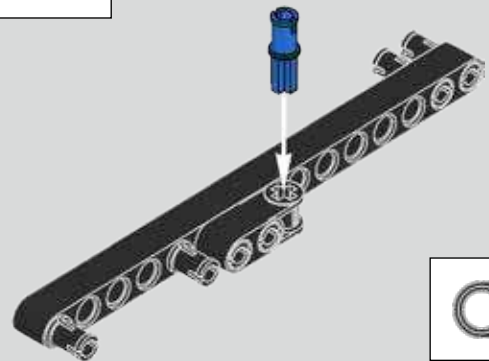

395

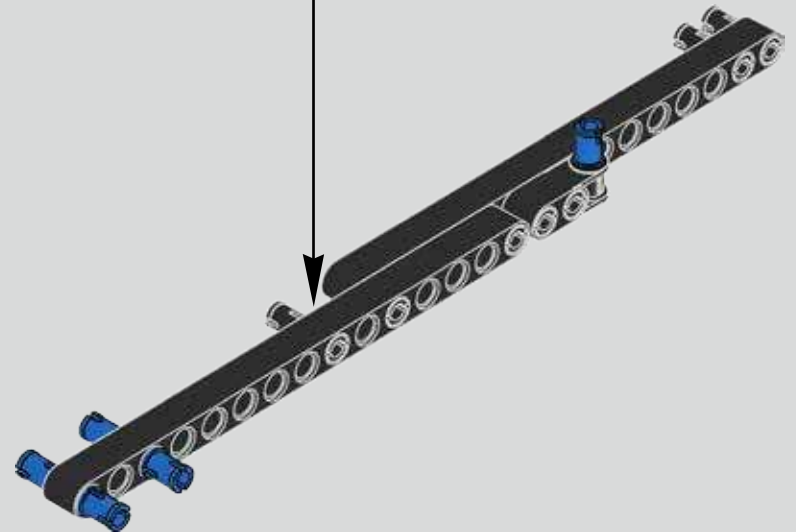
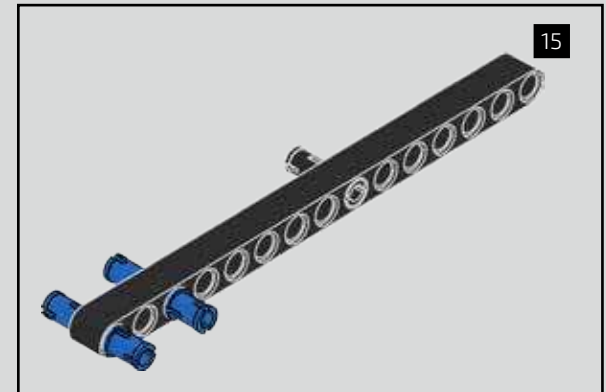

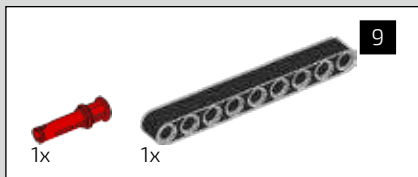

396

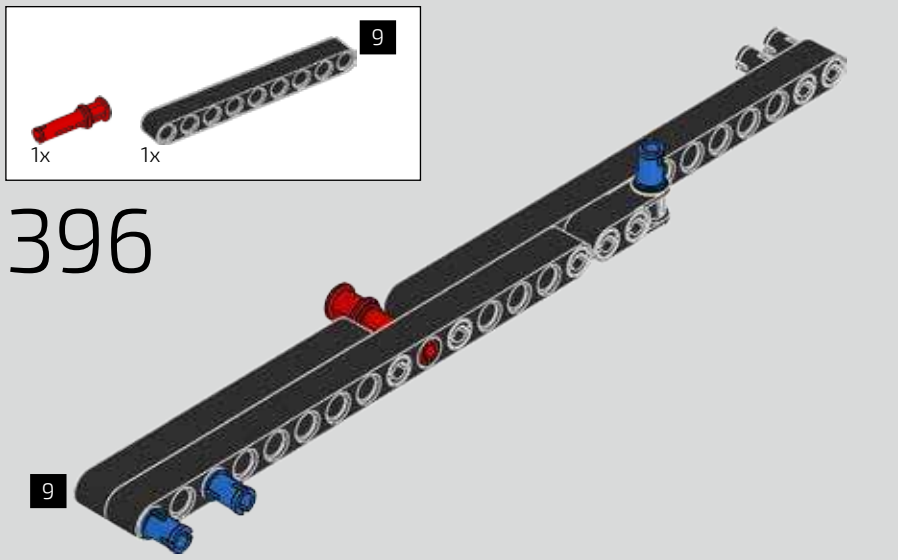

397

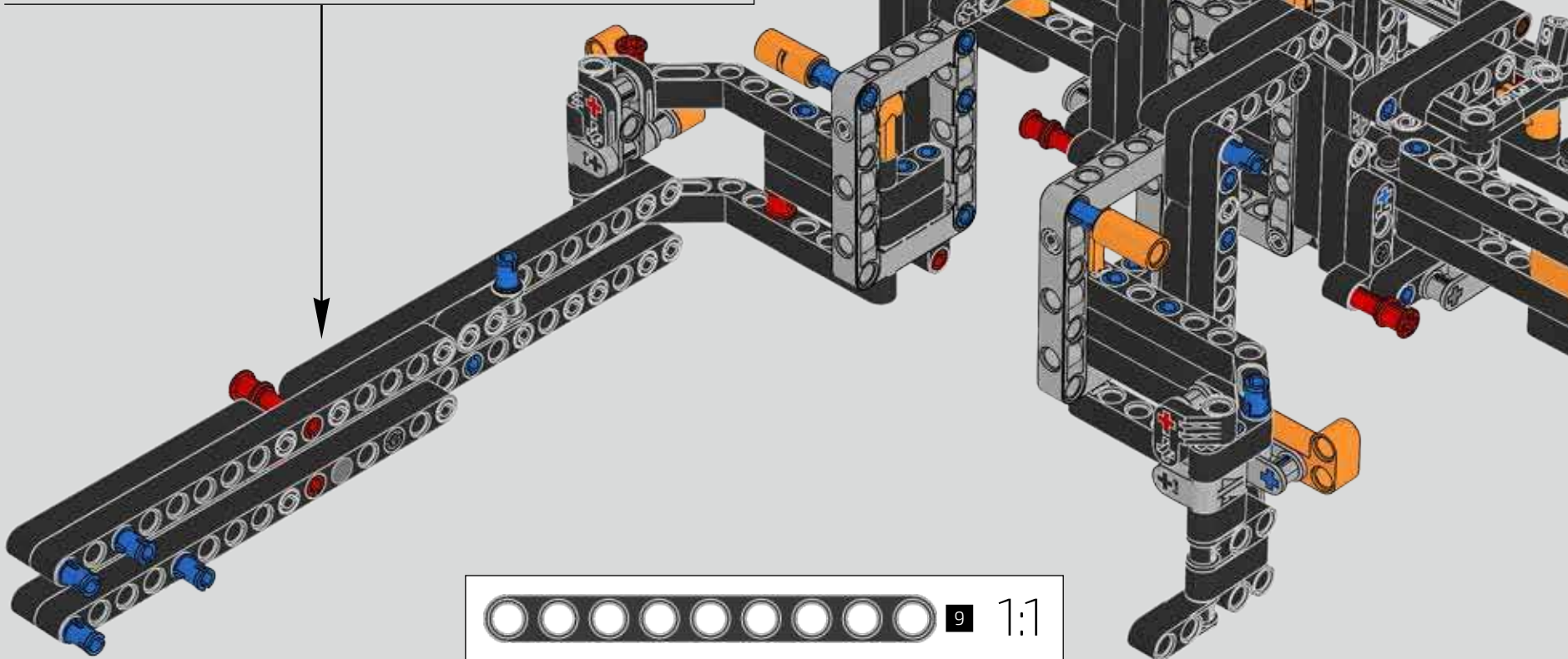



398

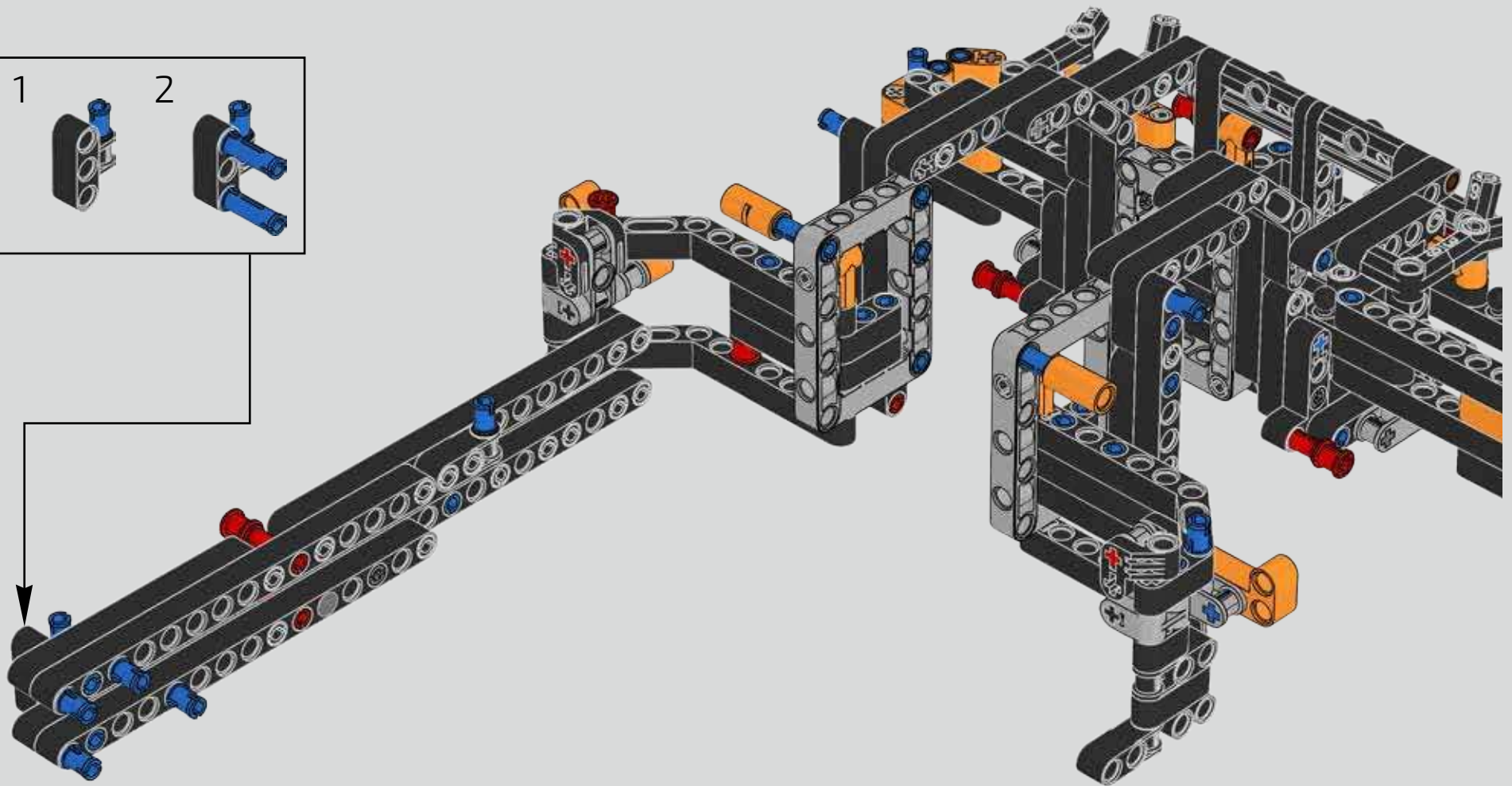
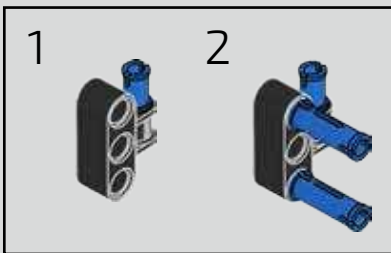

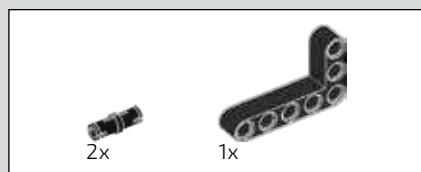

399

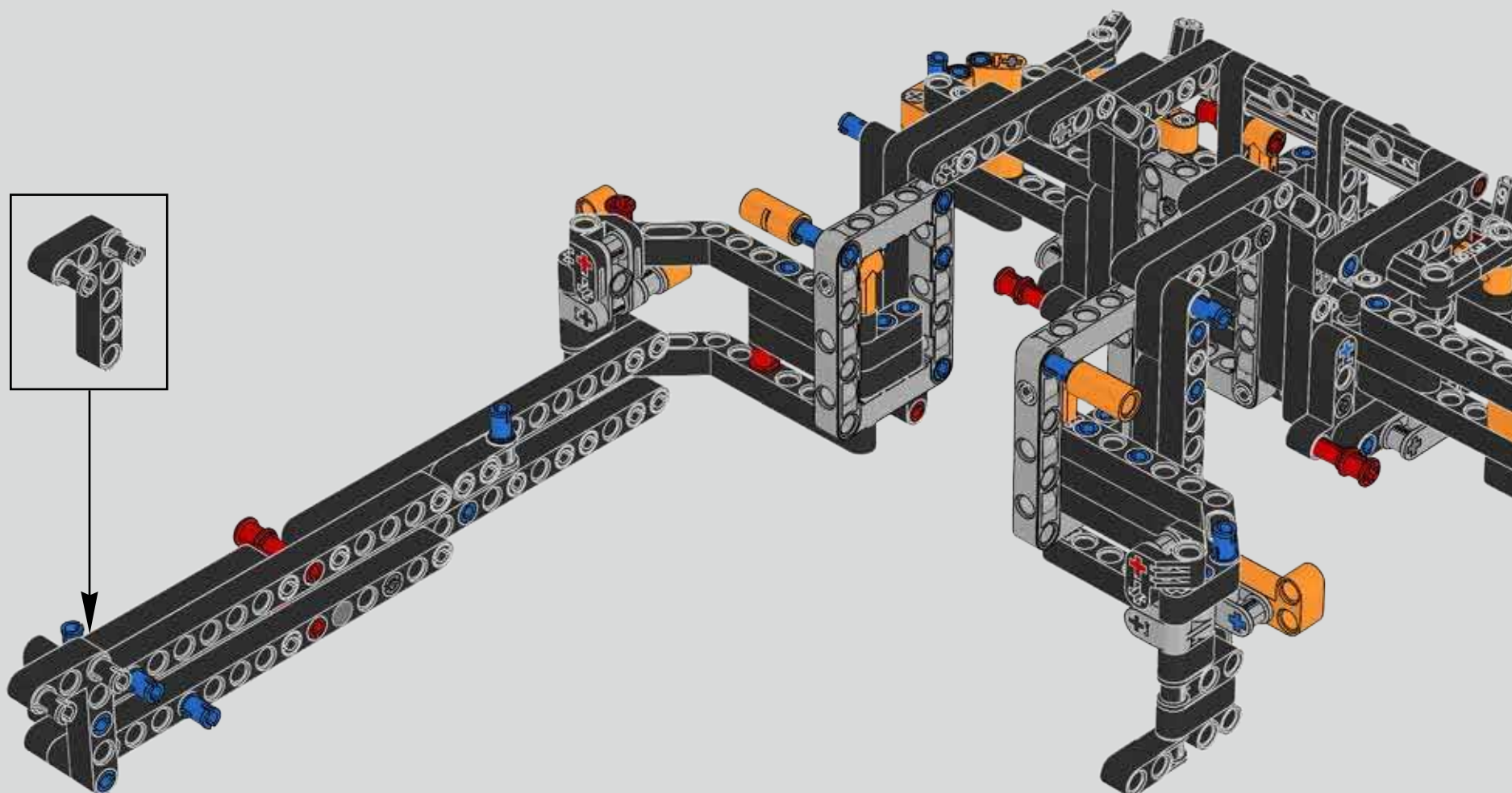

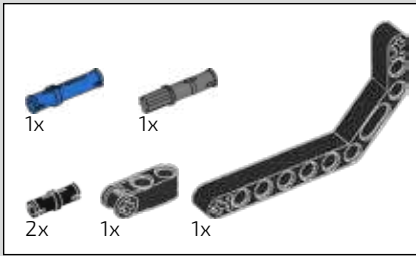

400

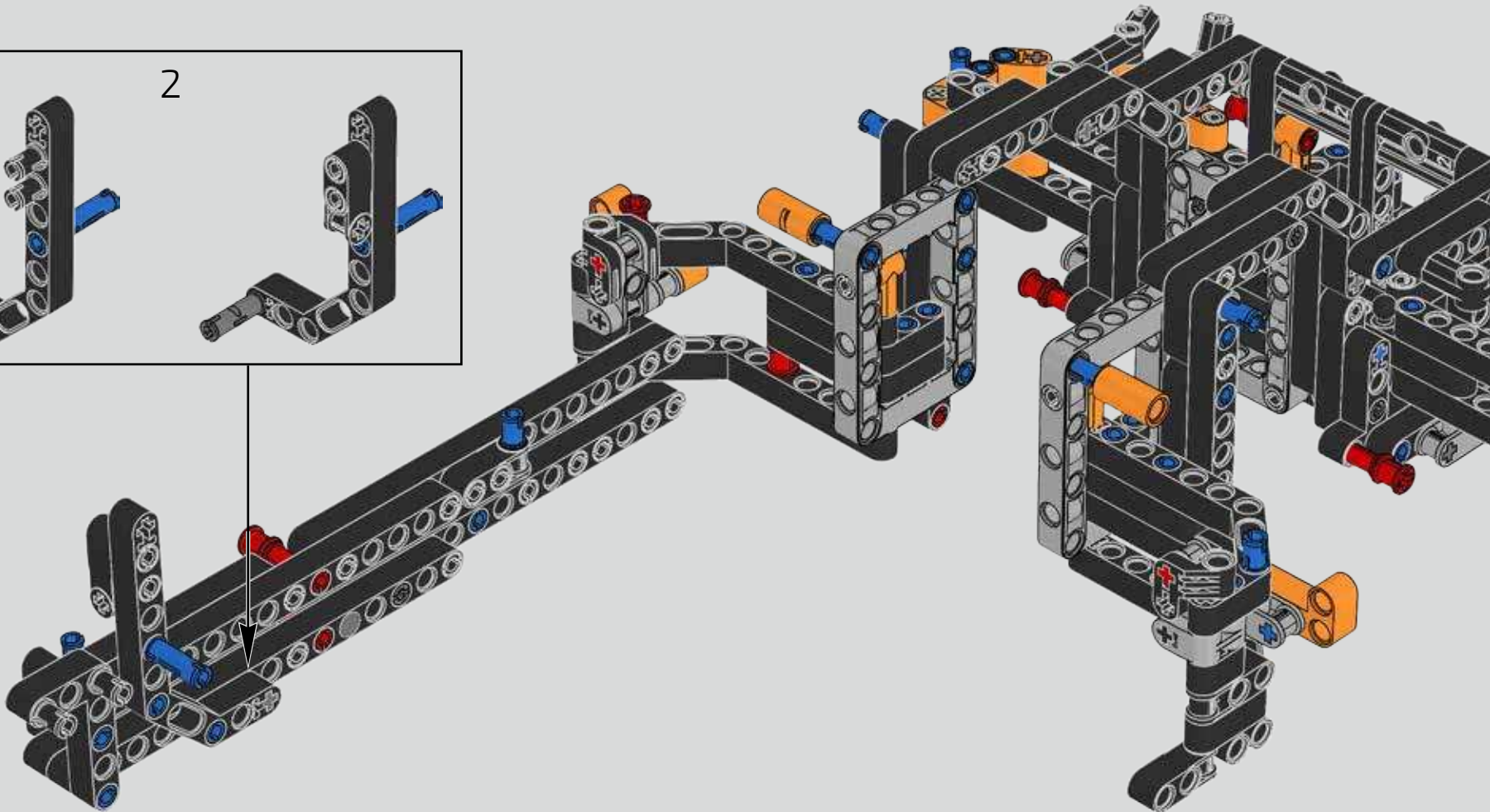
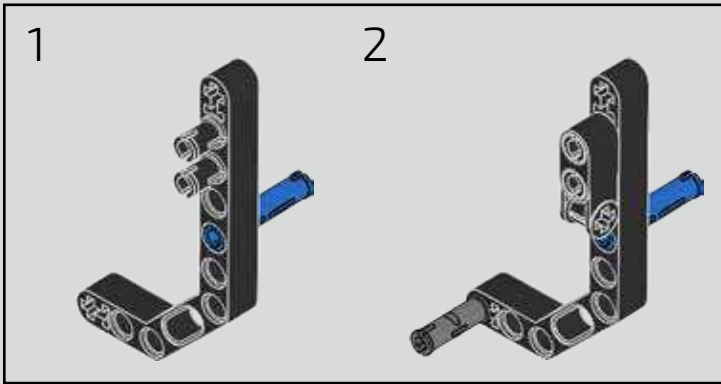



401



402

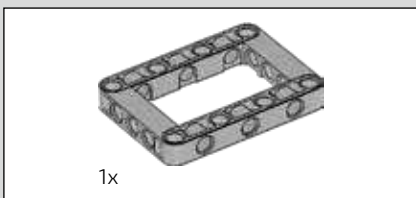
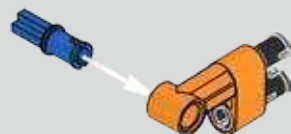

403

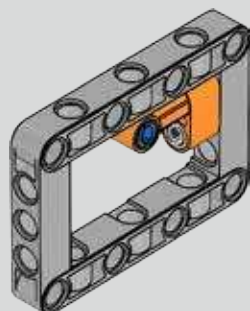

404

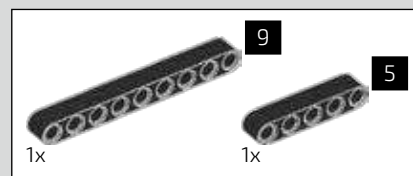
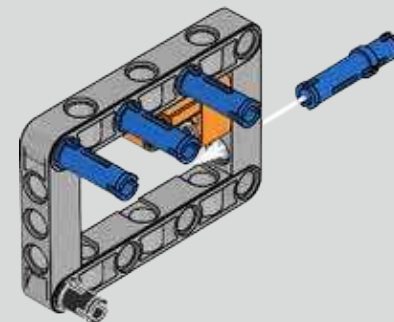

405

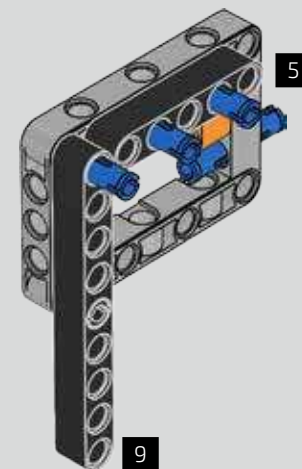

406

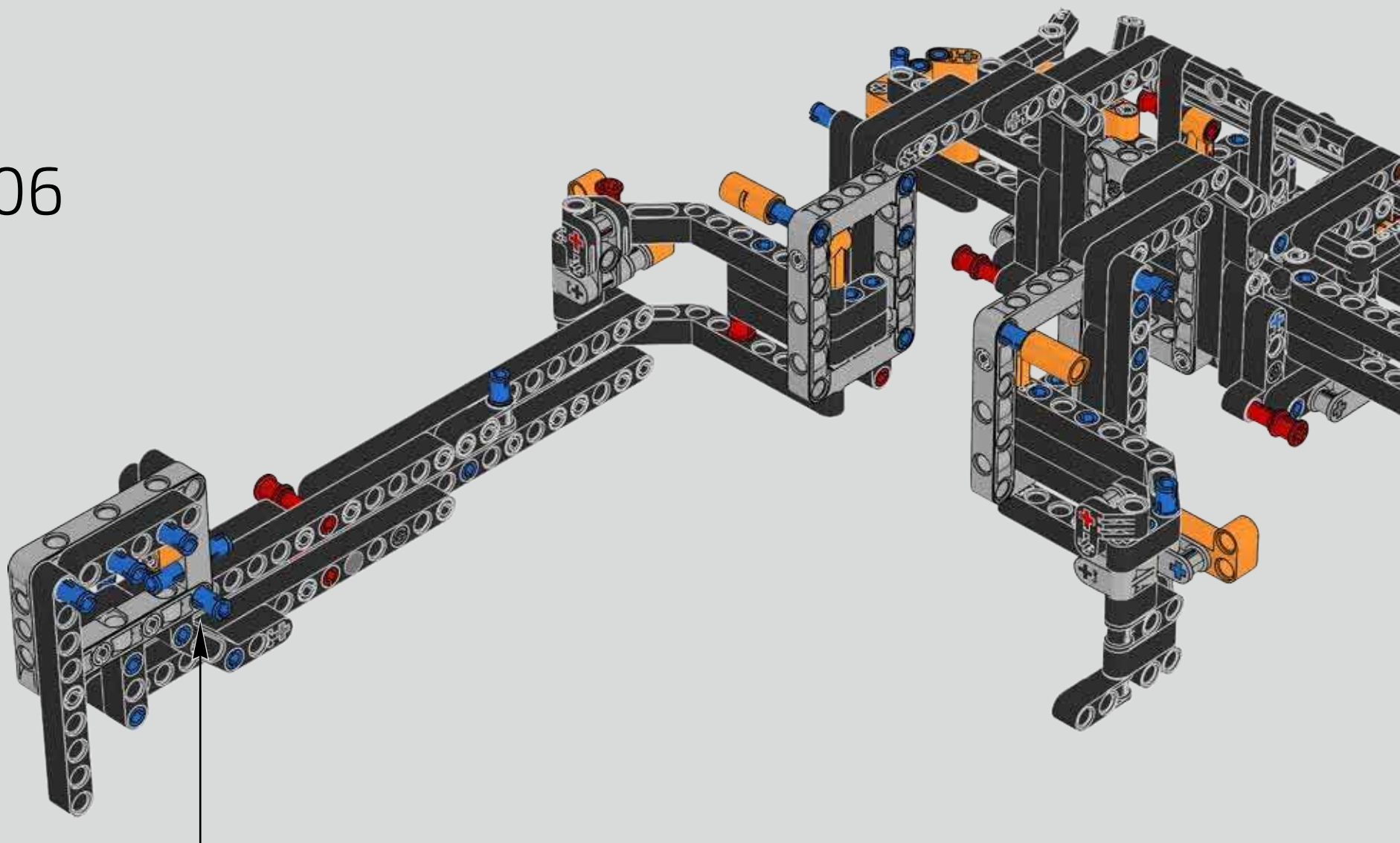

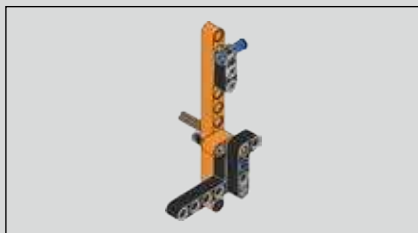

407

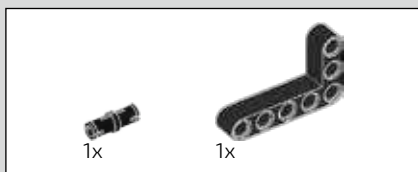
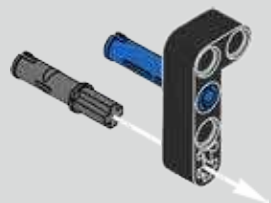

408

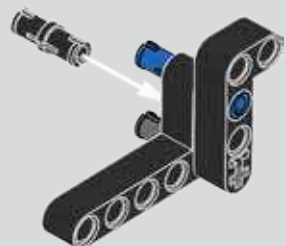

409

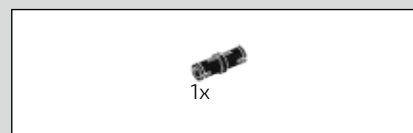
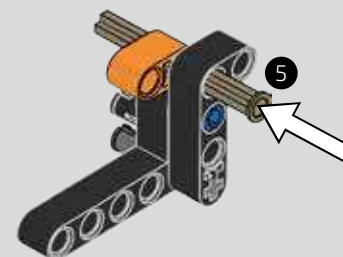

410

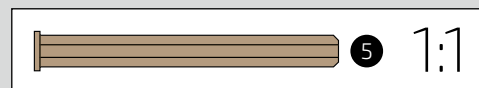
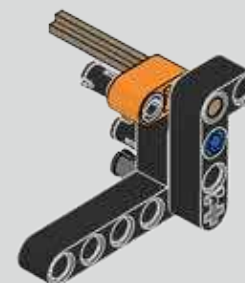

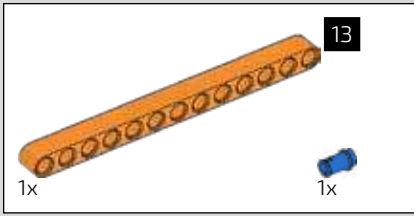

411

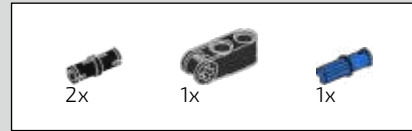
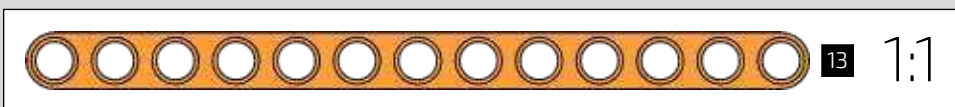
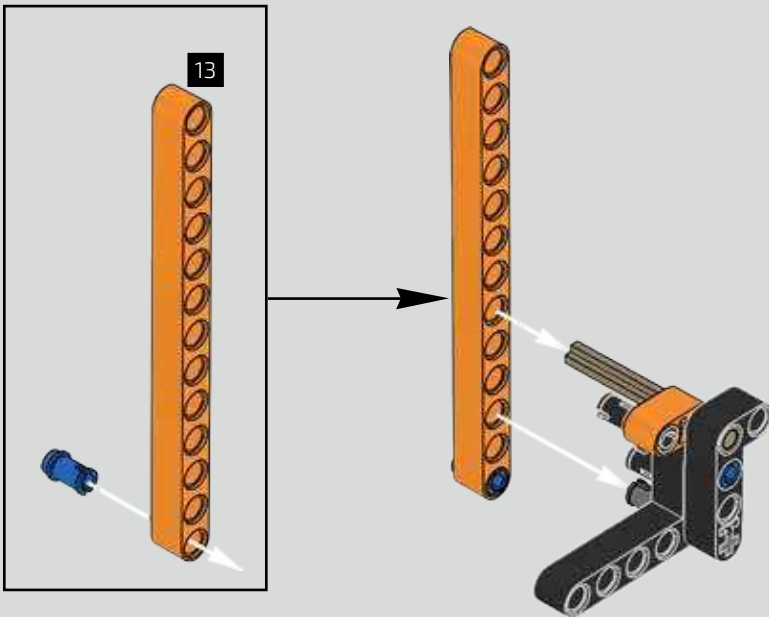

412

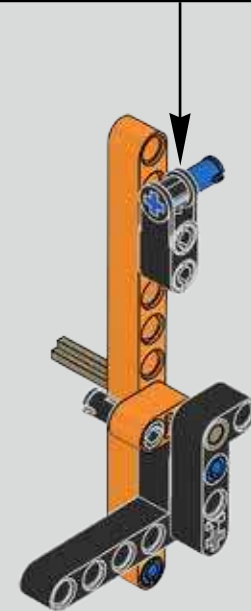
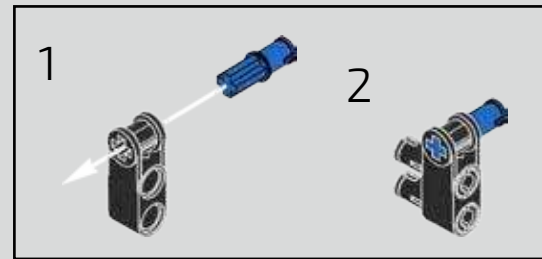

413

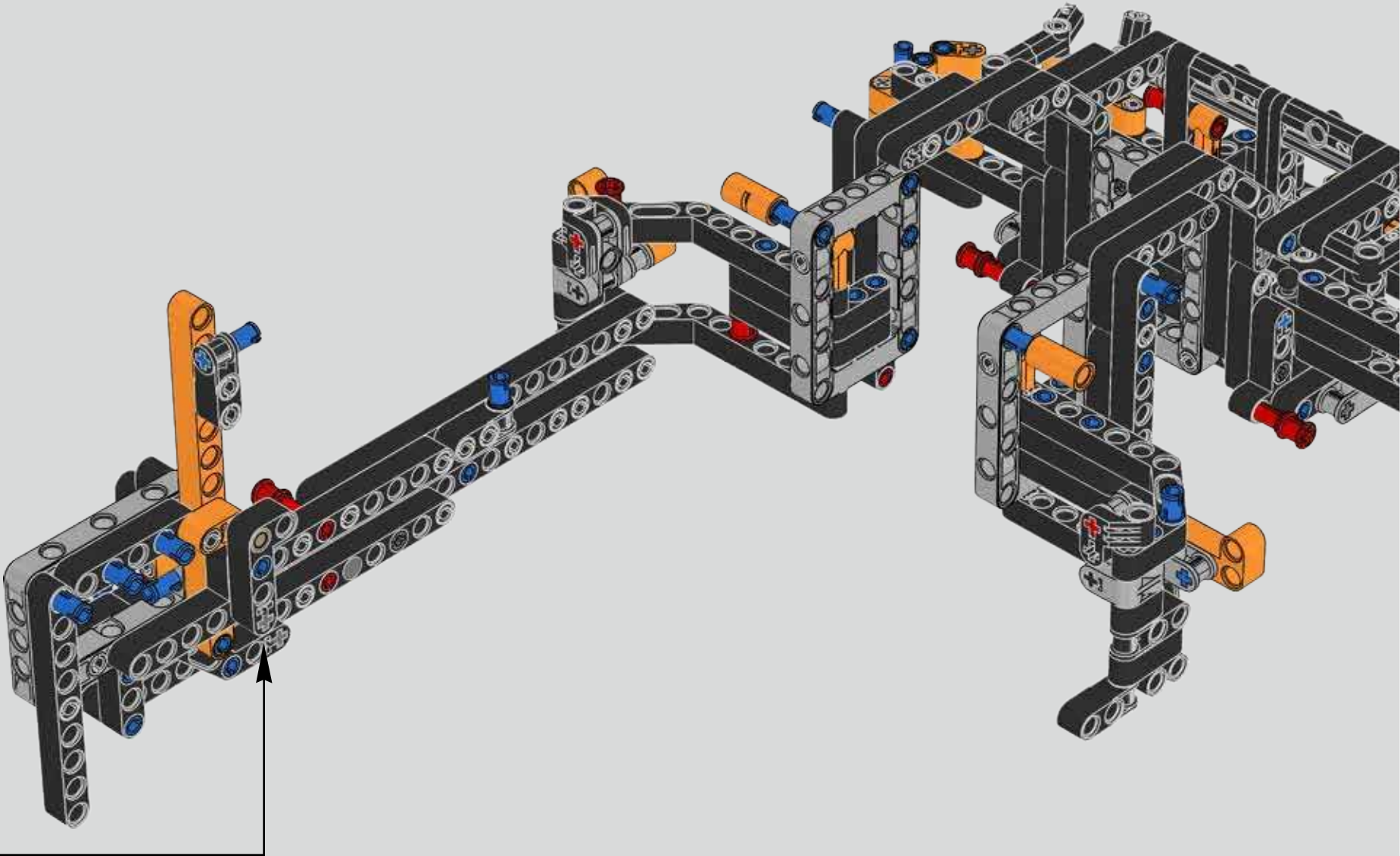

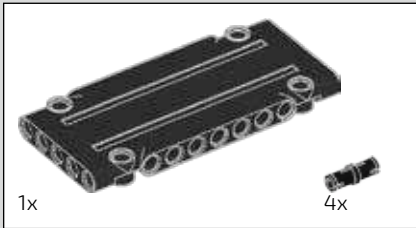
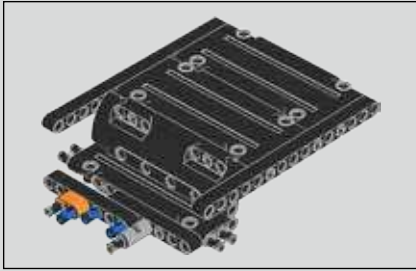

1x

4x

414

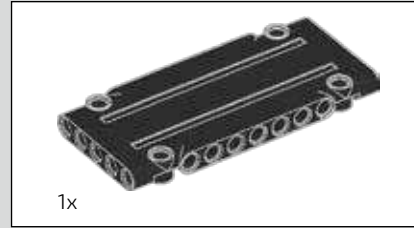
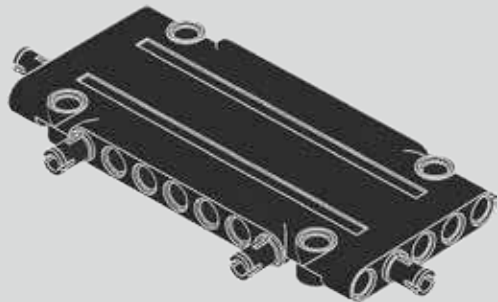

1x

415

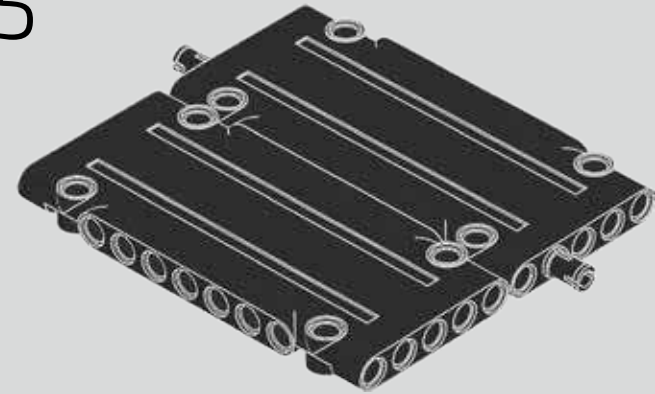

6x

416

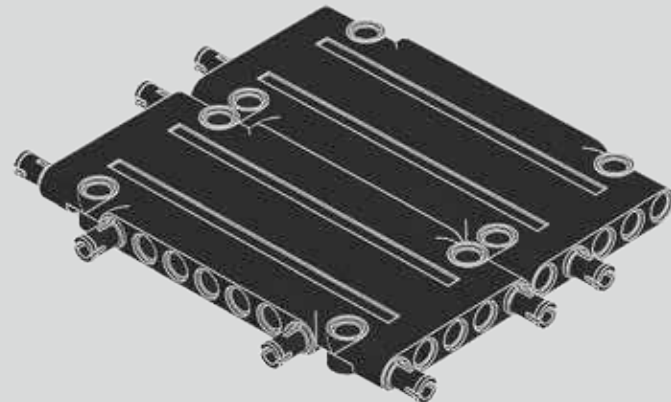



417

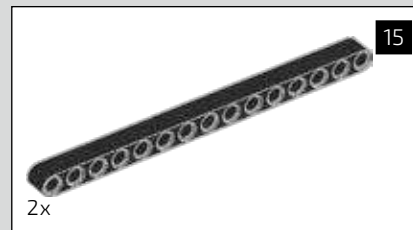
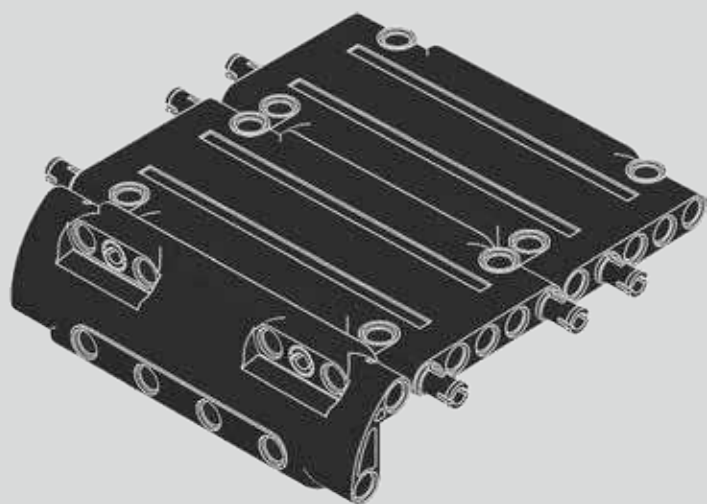

418

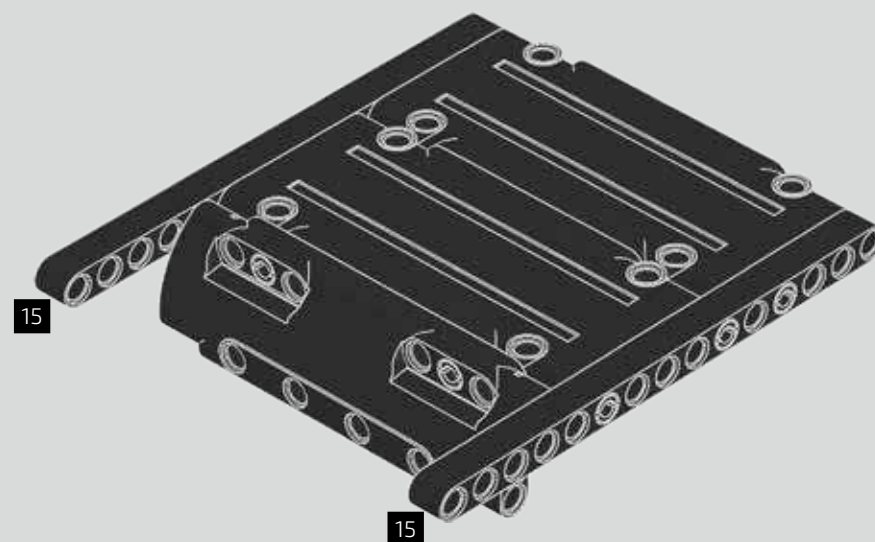

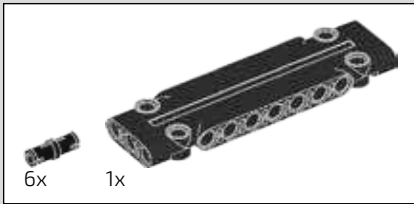

419

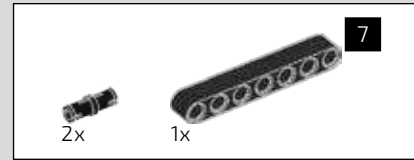
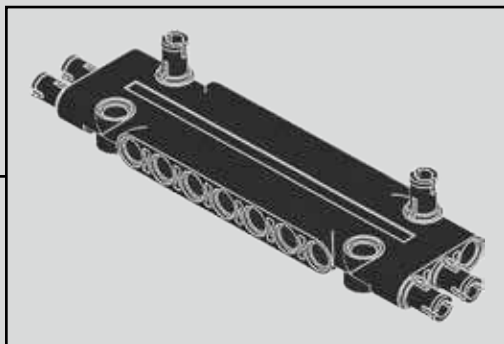
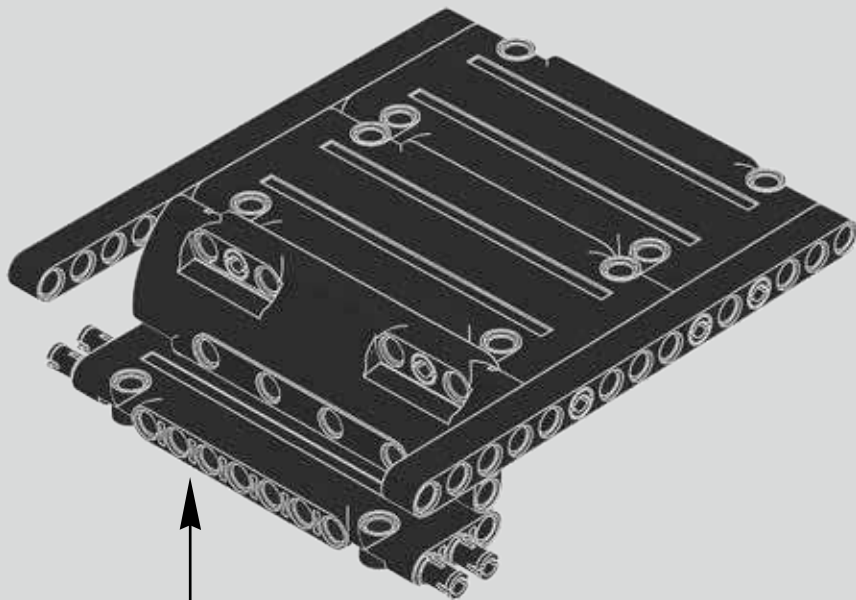

420

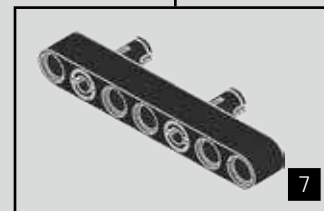
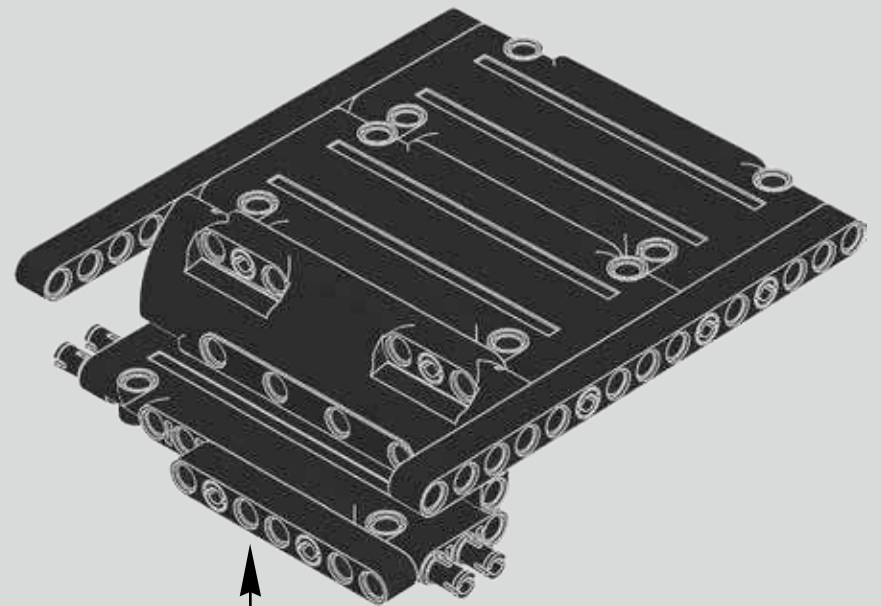



421

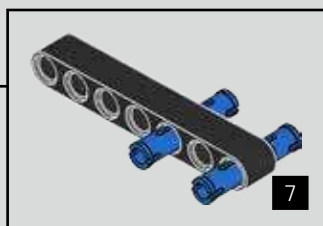
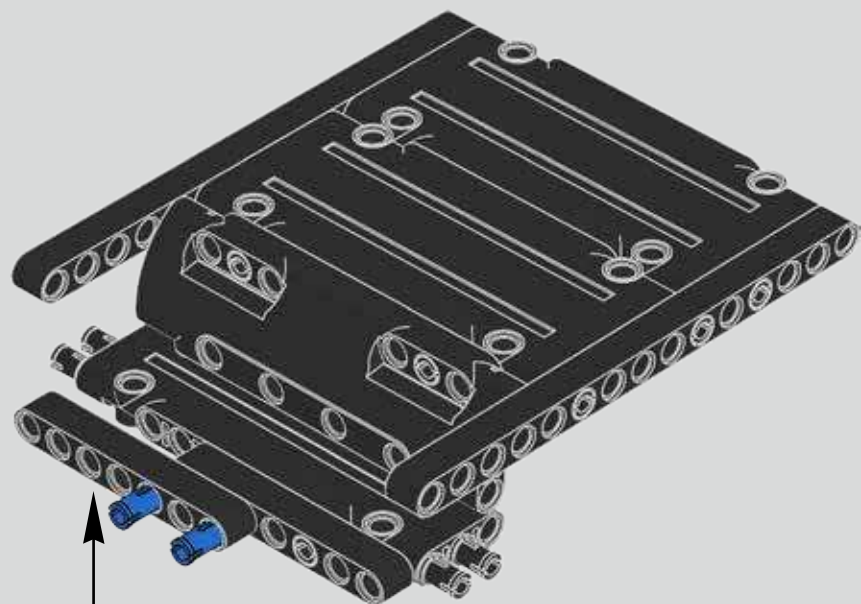

422

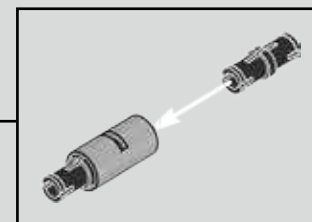
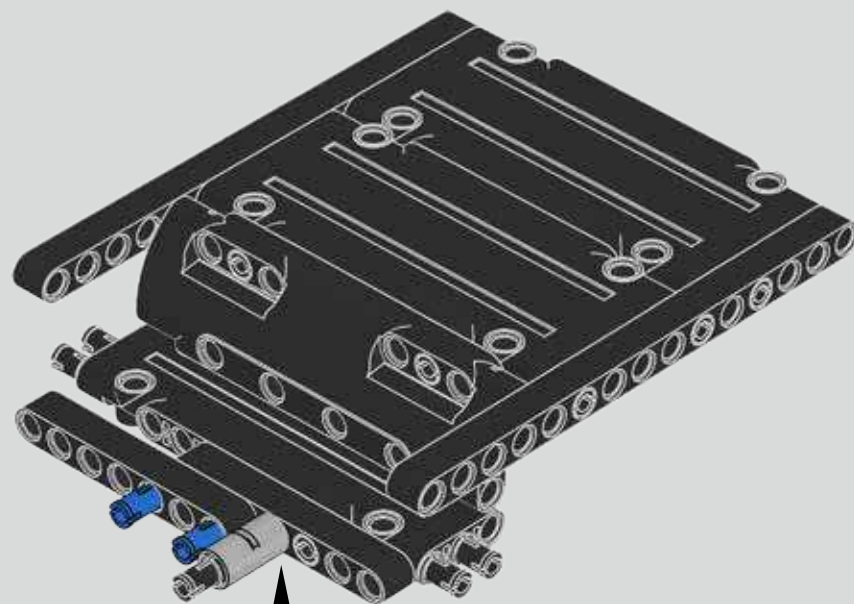

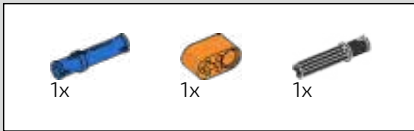

423

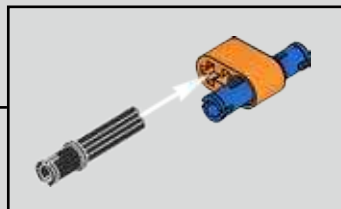
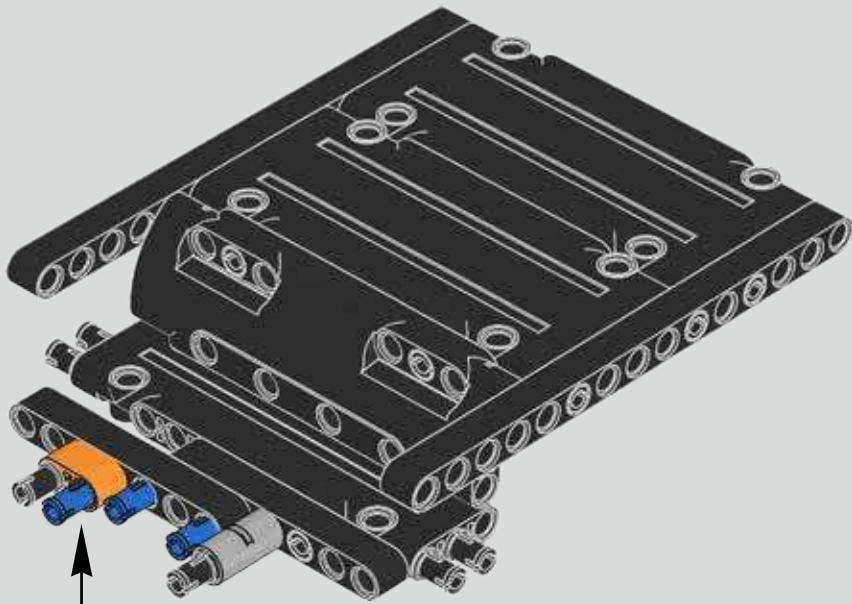

424

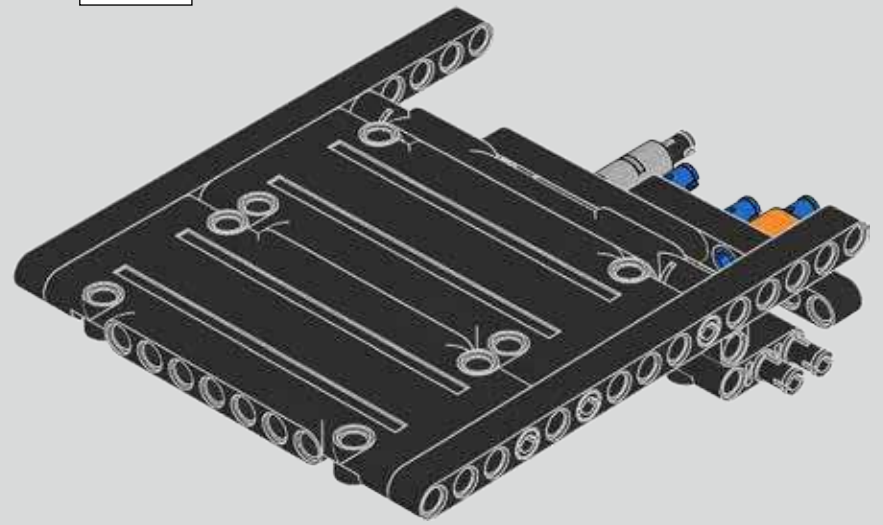
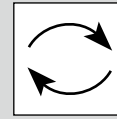

425

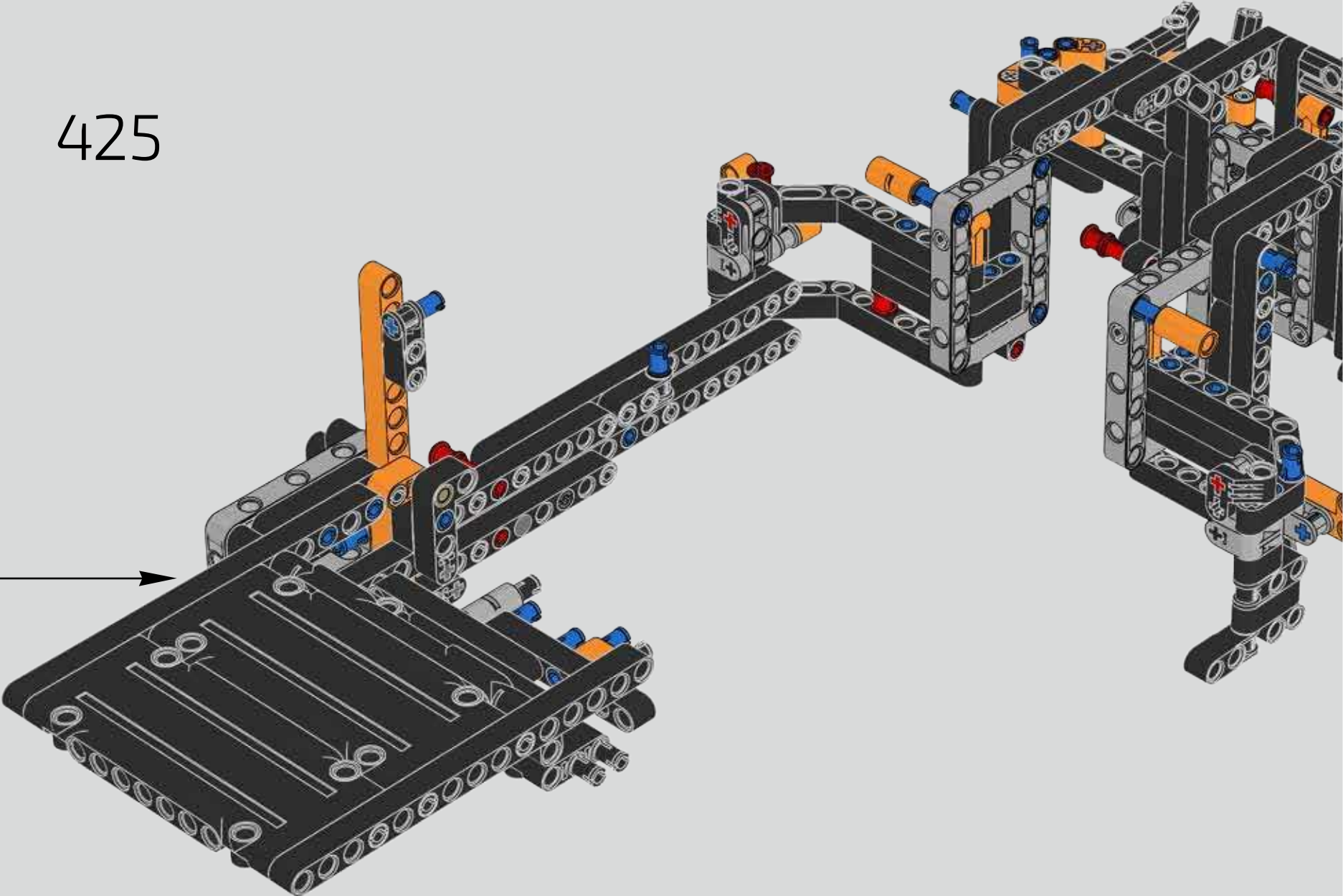

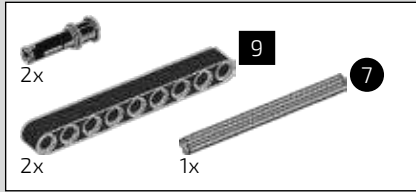

426

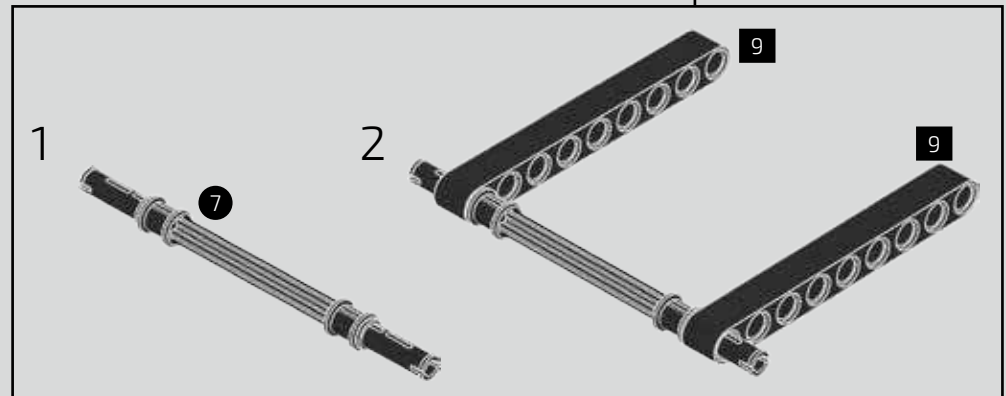
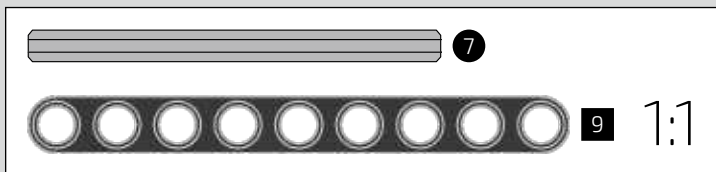
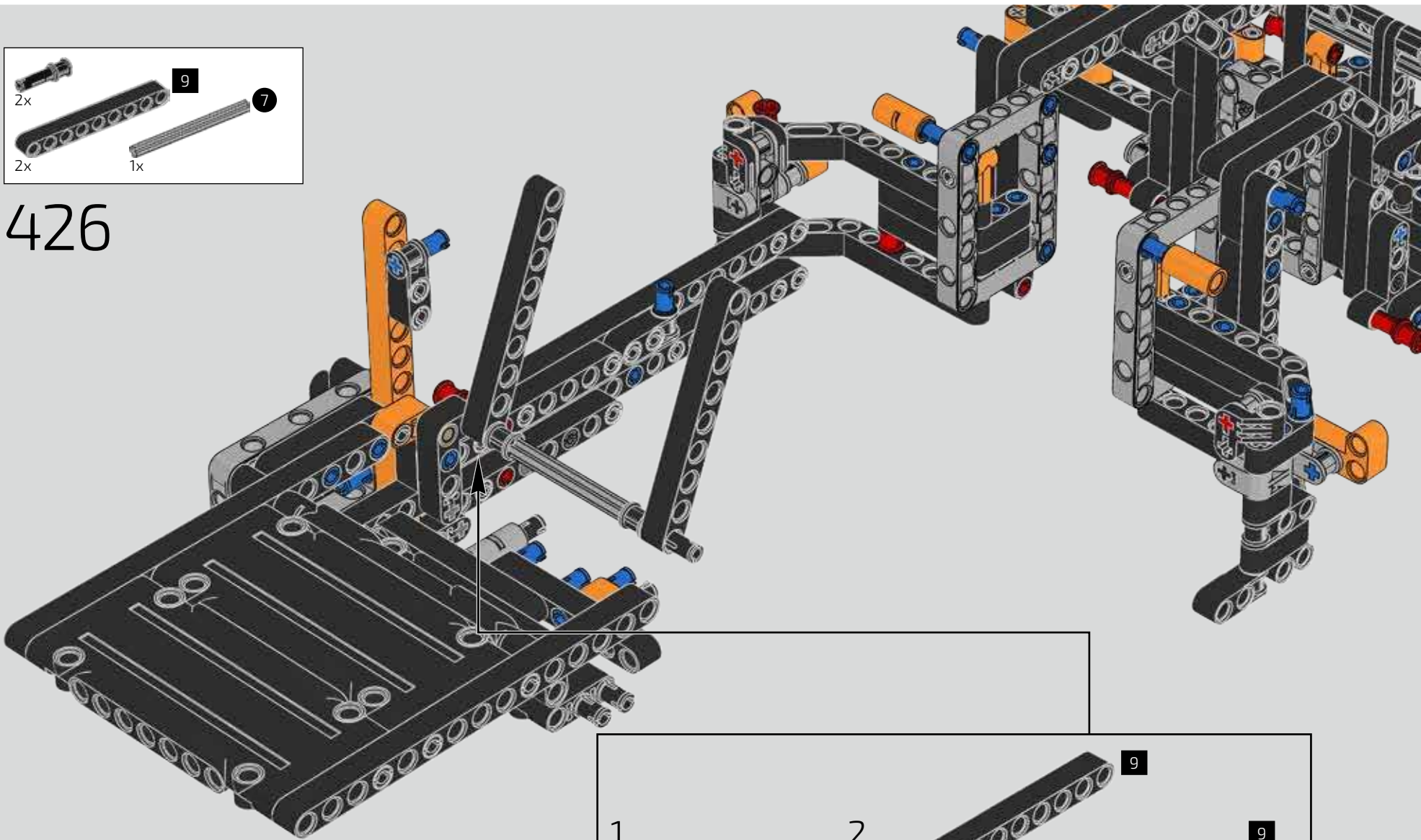

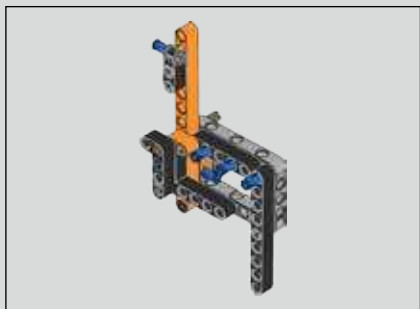

427

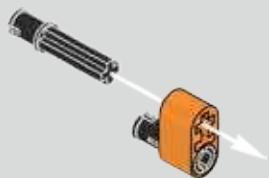

428

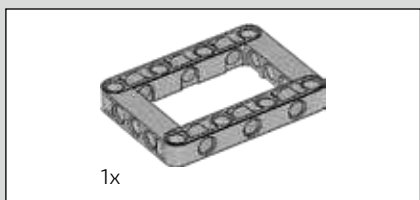
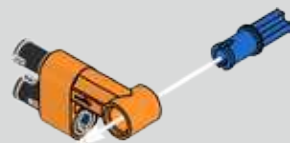

429

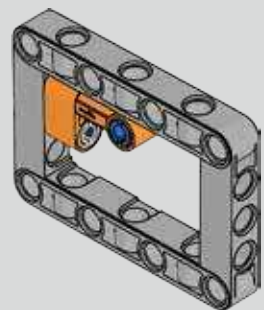

430

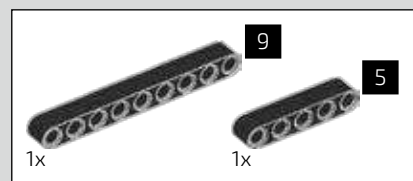
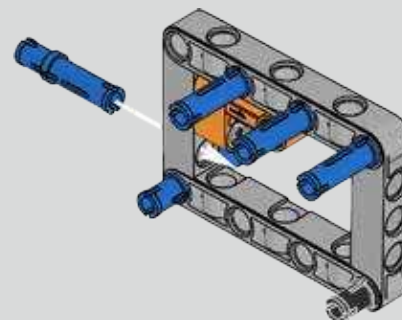

431

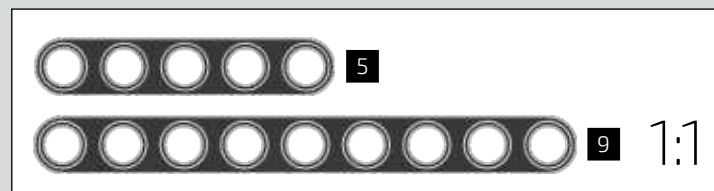
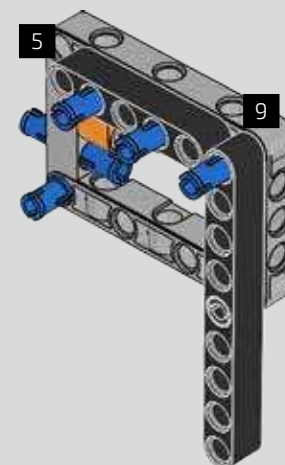

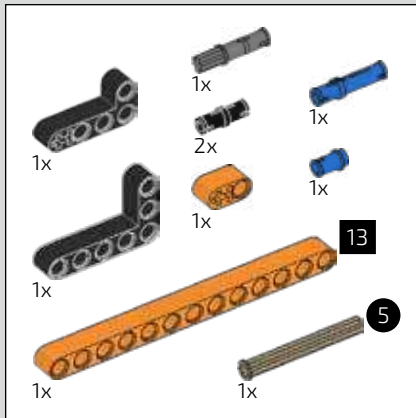

432

1



2

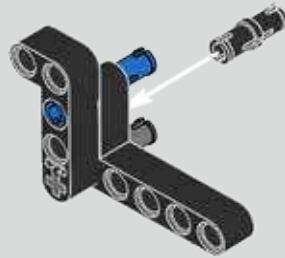

3

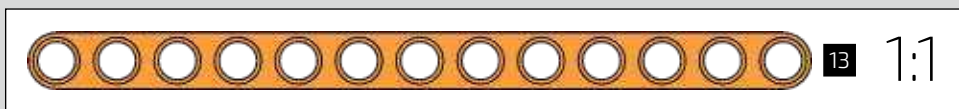
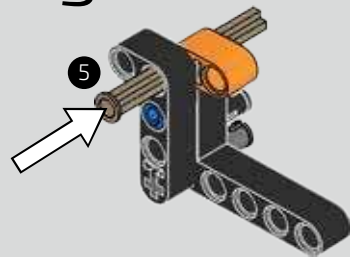

4

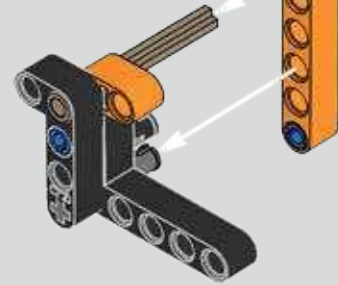

5

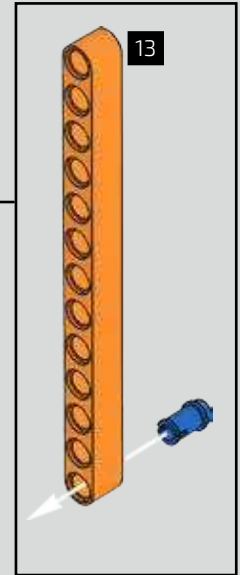
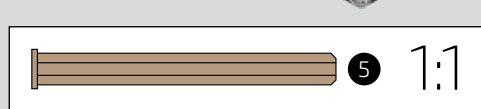
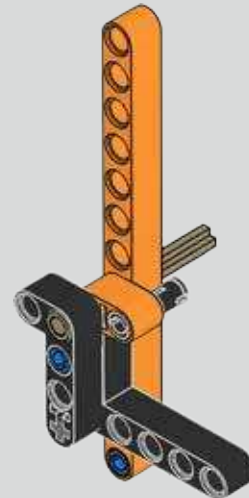

433

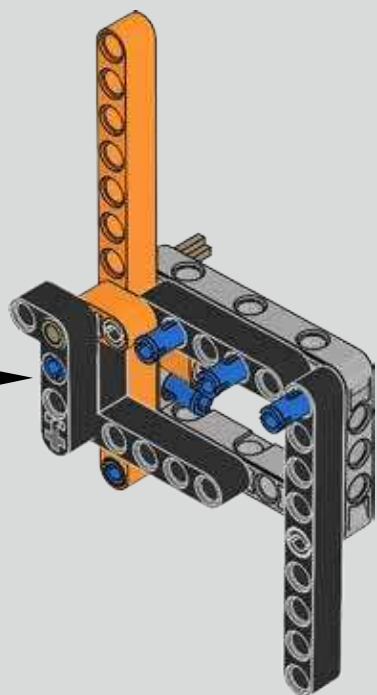

434

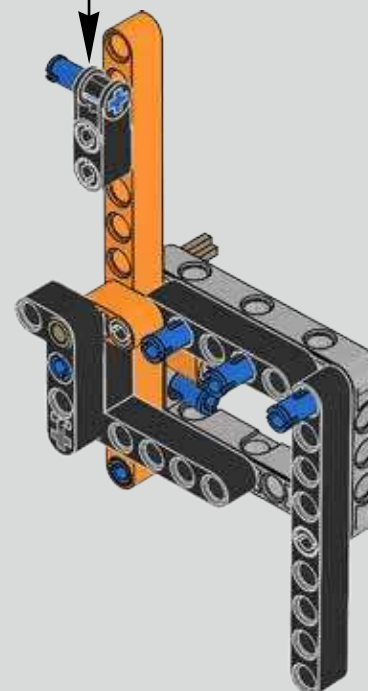
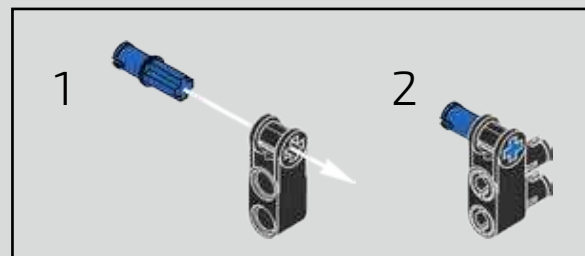

435

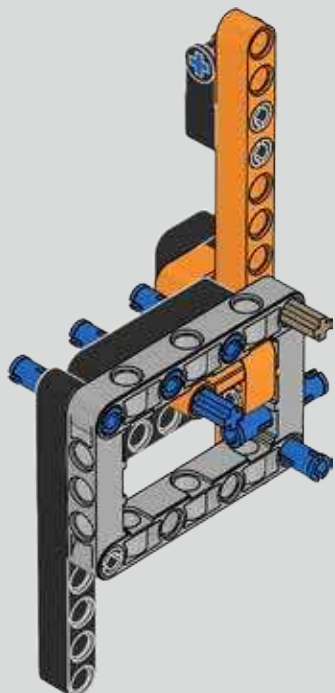
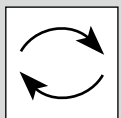

436

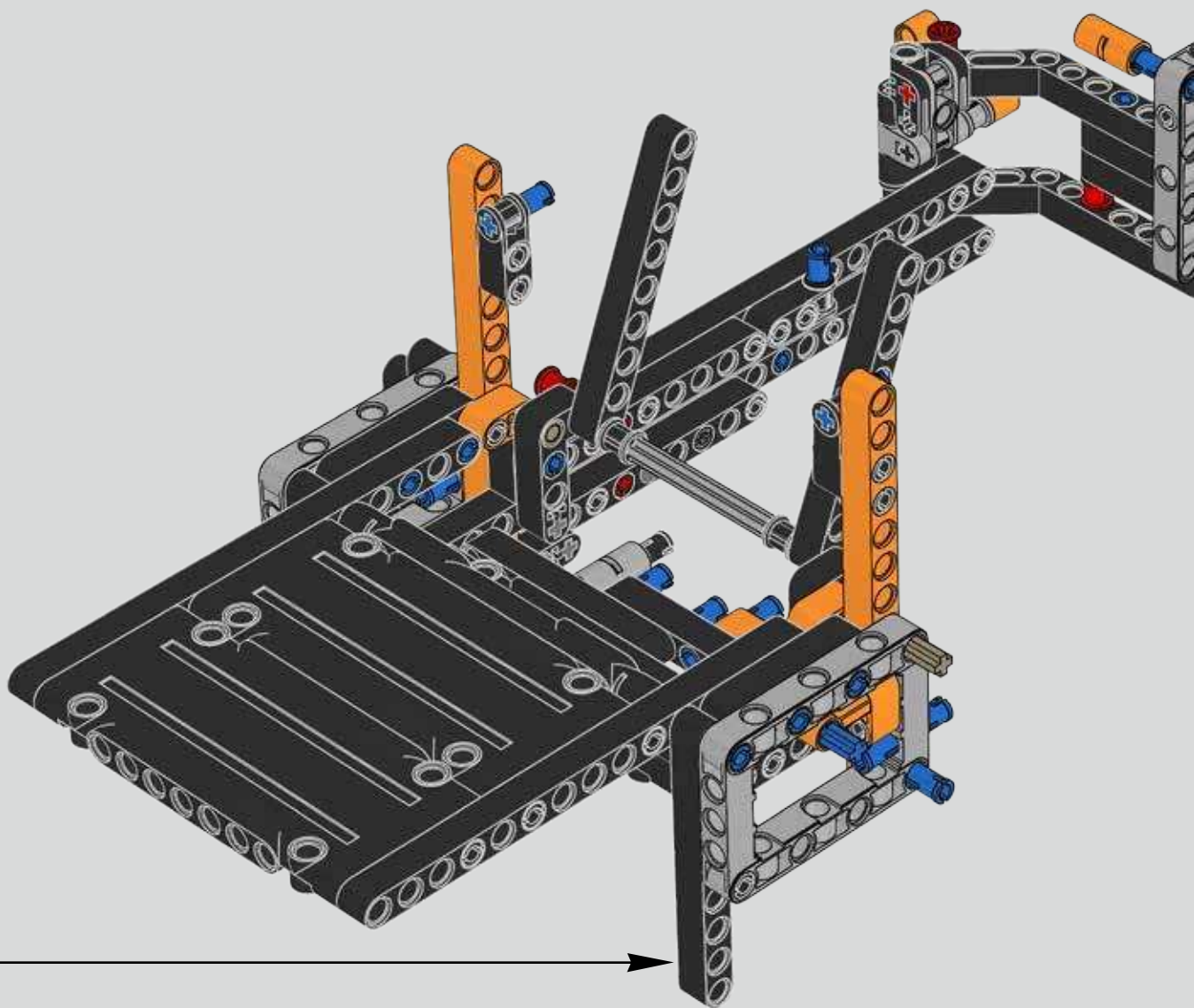

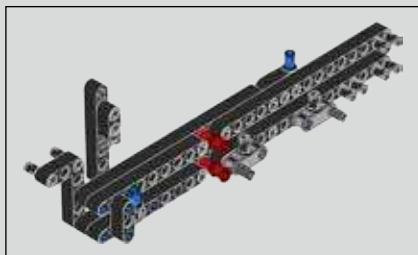

437

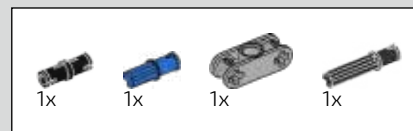
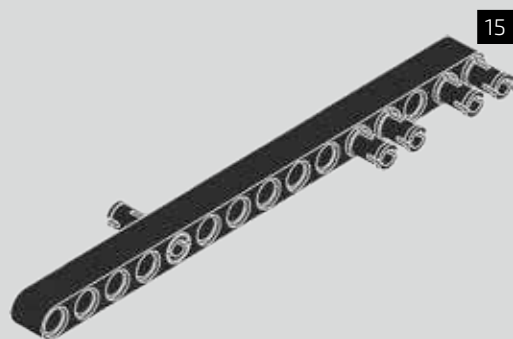

438

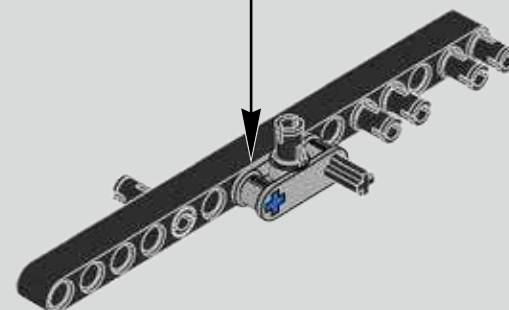
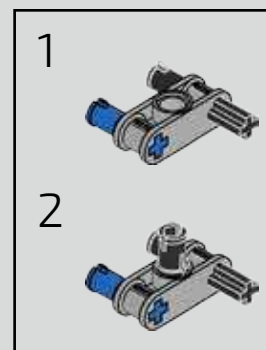

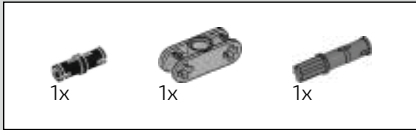

439

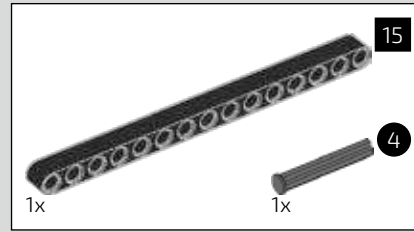
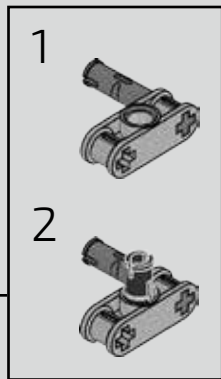
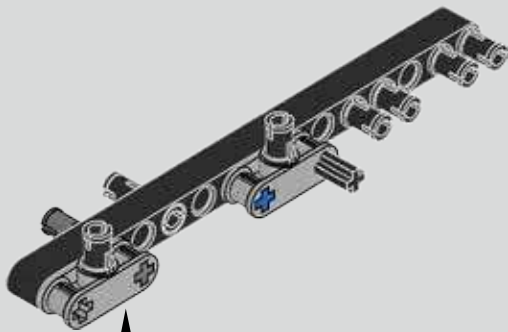

440

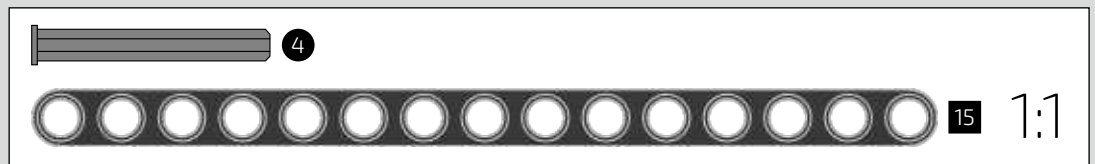
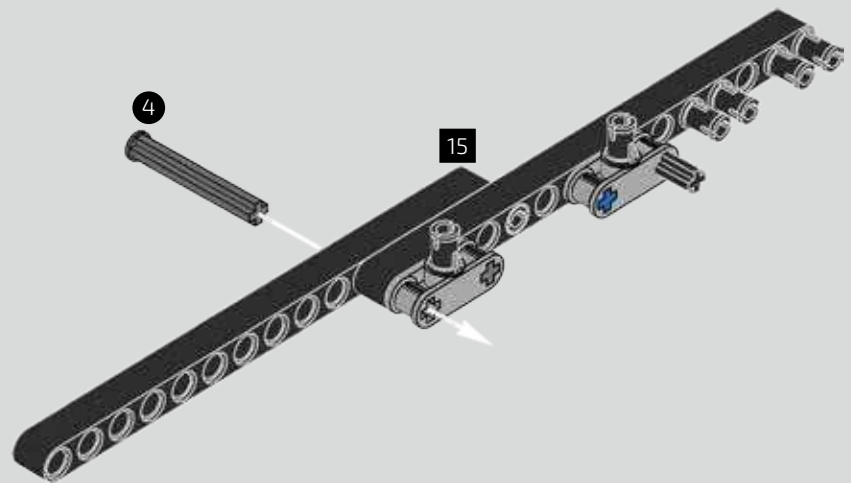



441

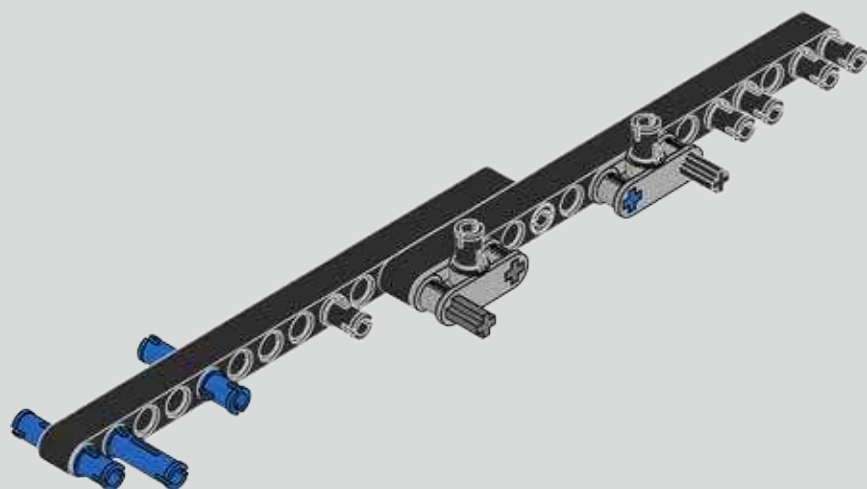

442

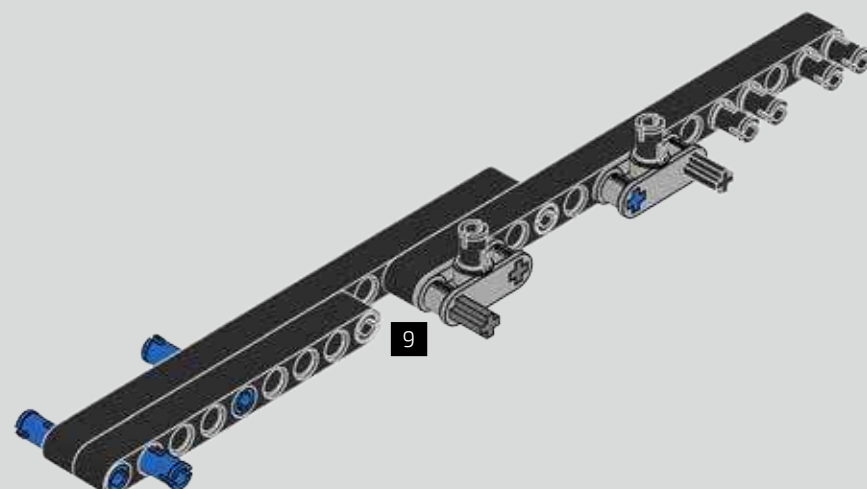

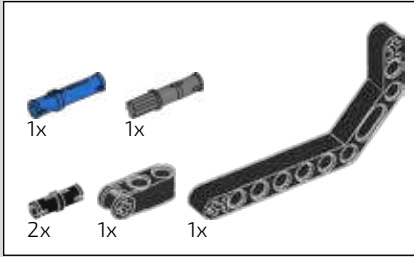

443

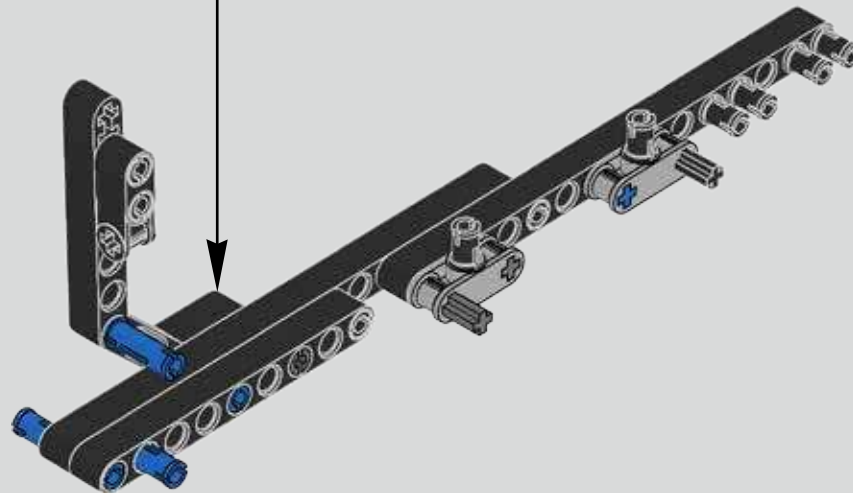
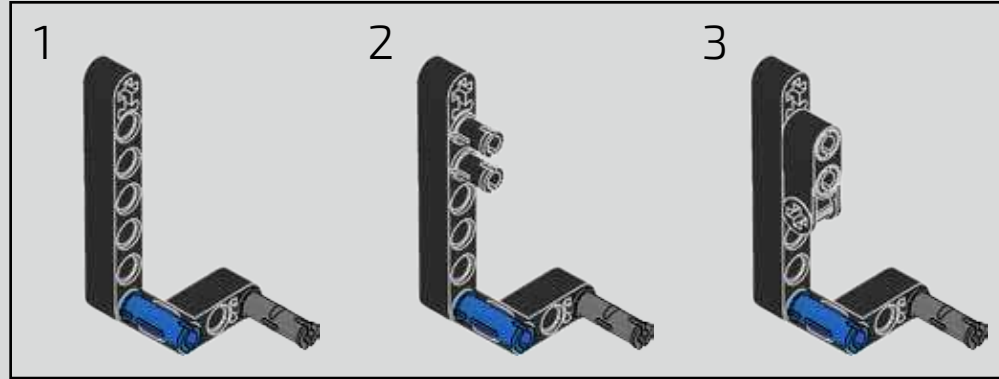

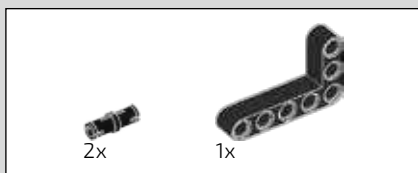

444

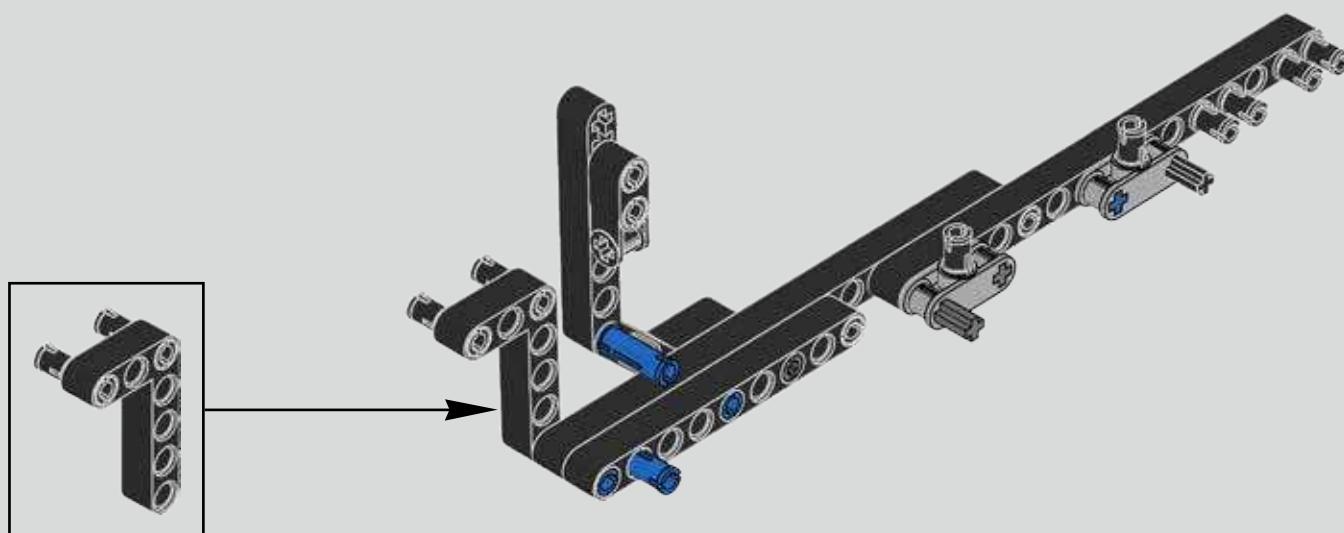

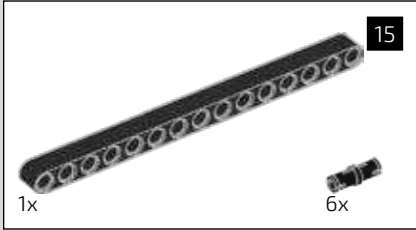
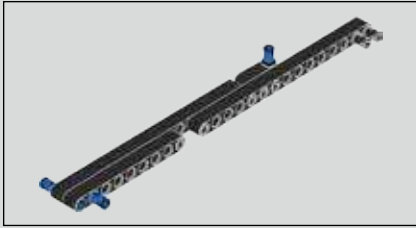

445

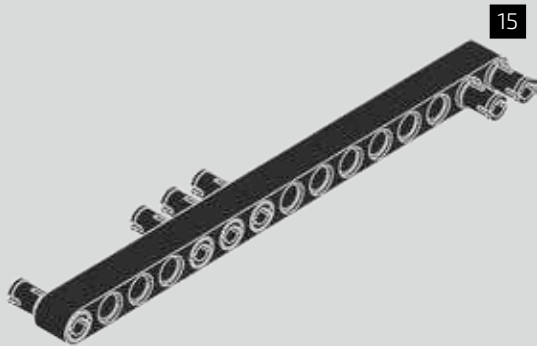

446

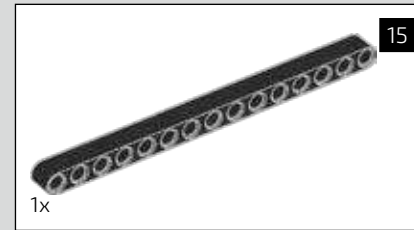
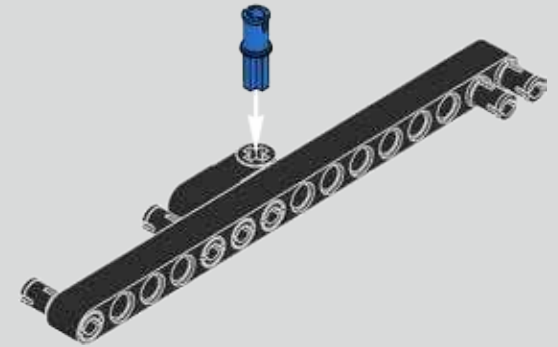

447

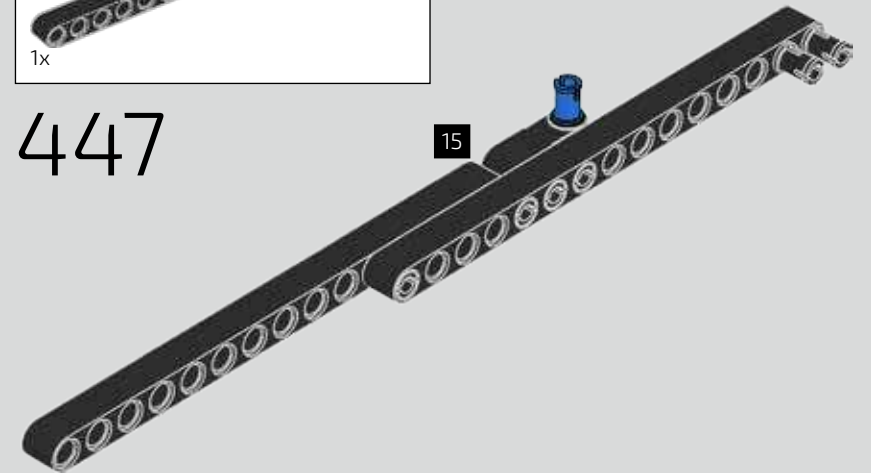



448

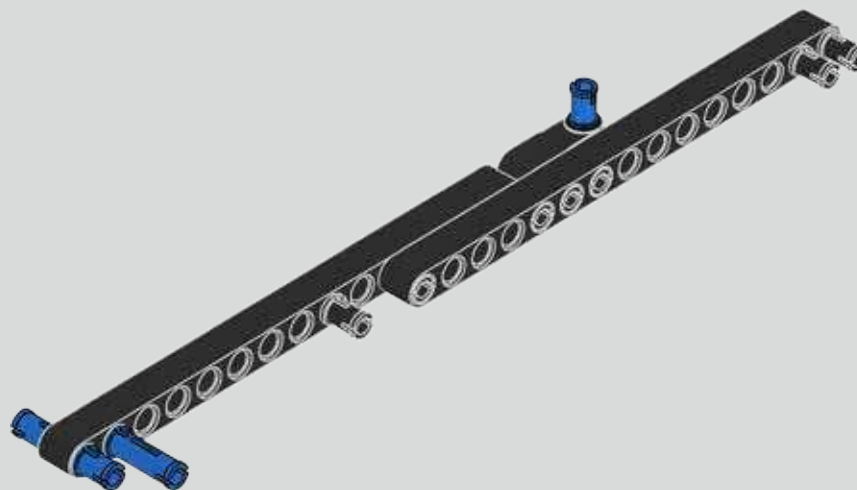

449



450

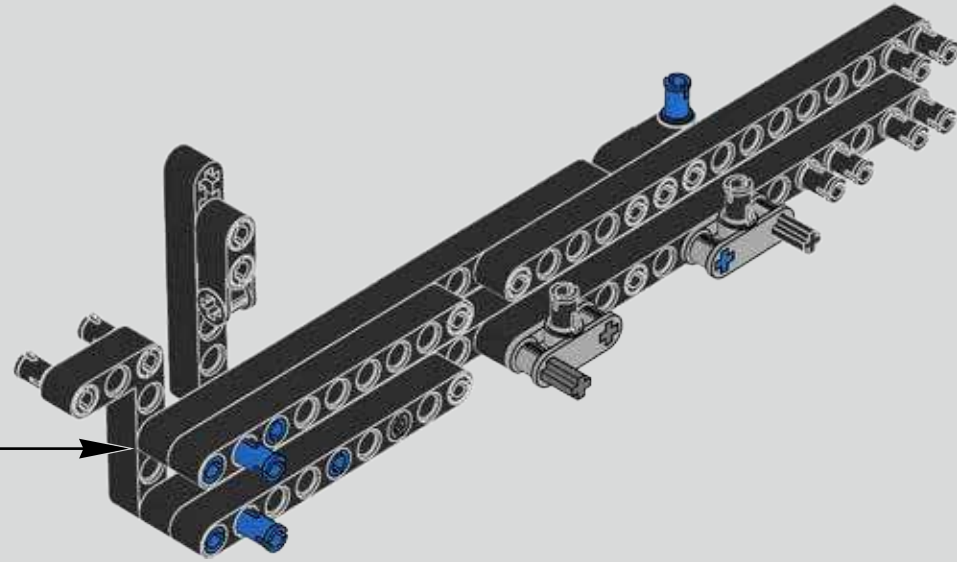

451

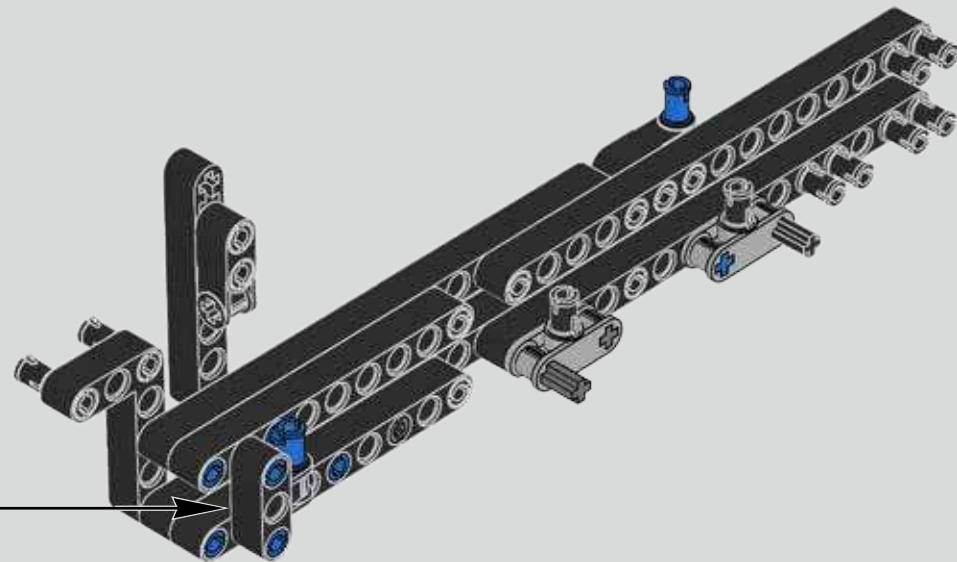
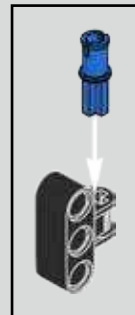



452

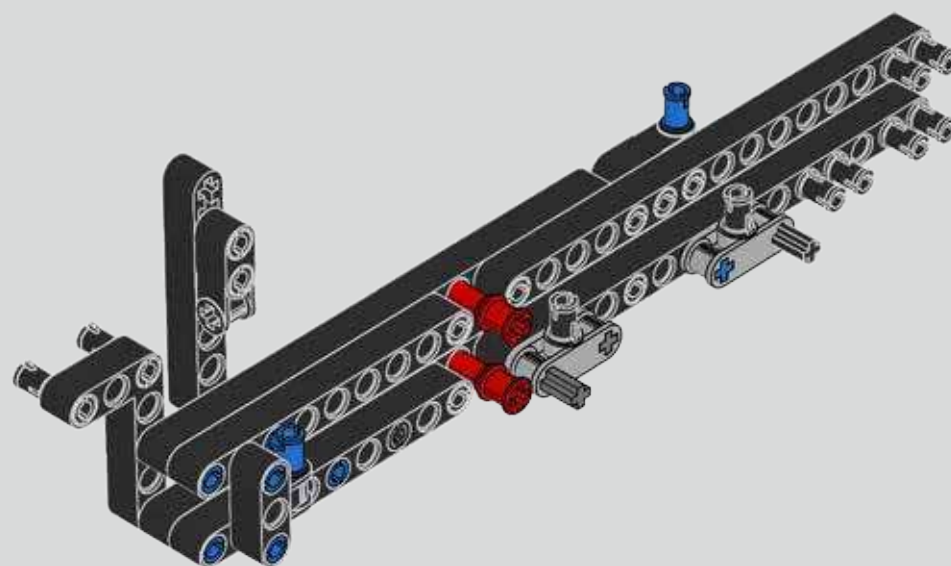

453

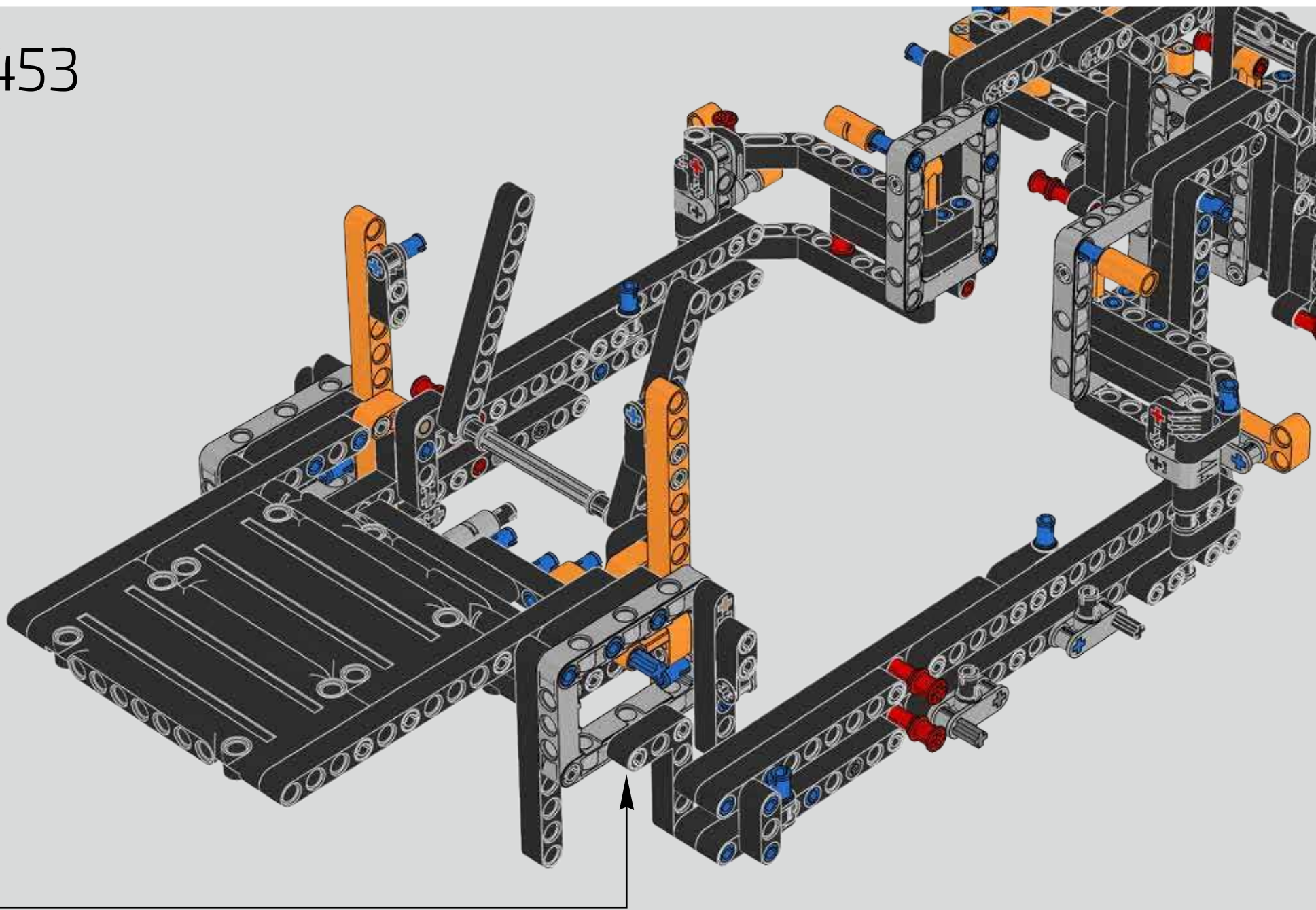

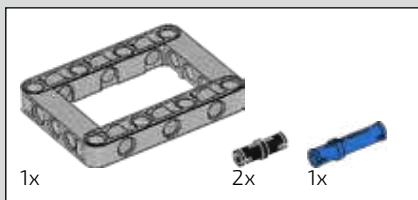
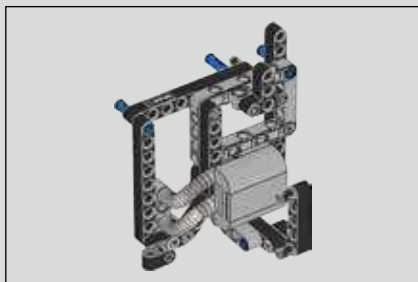

454

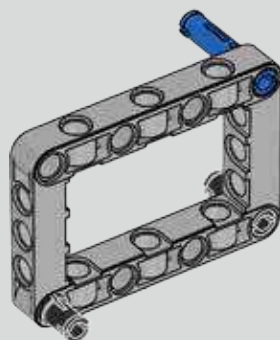

455

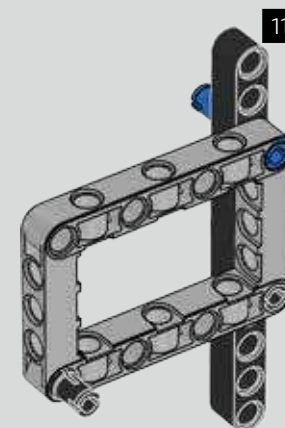

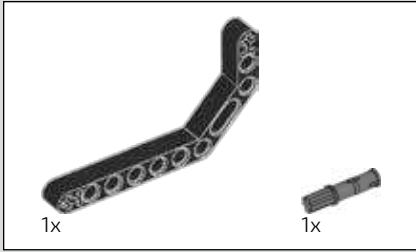

456

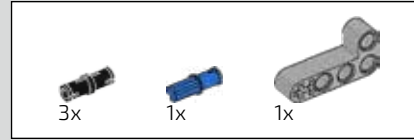
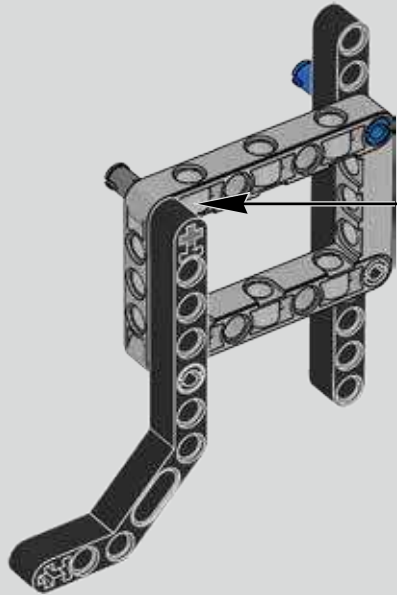
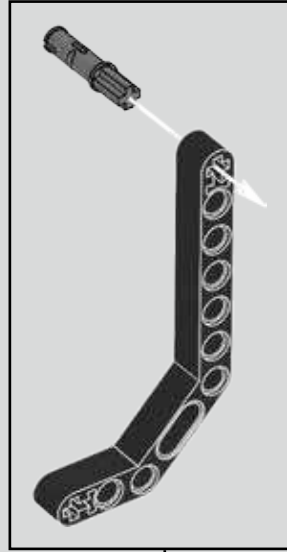

457

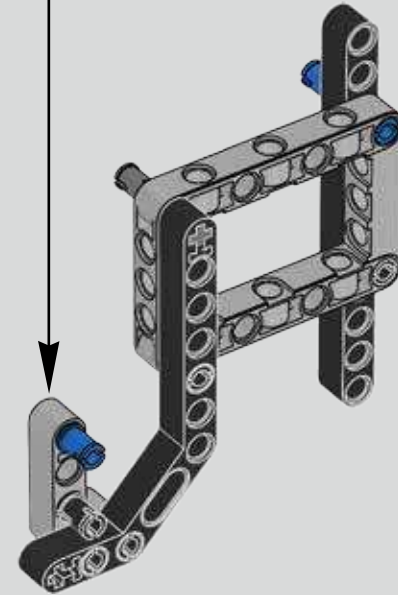
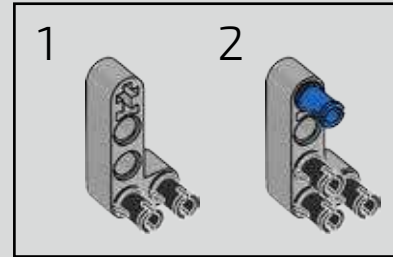

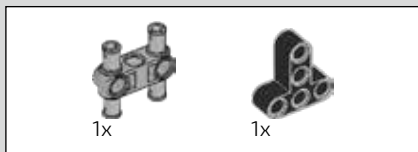

458

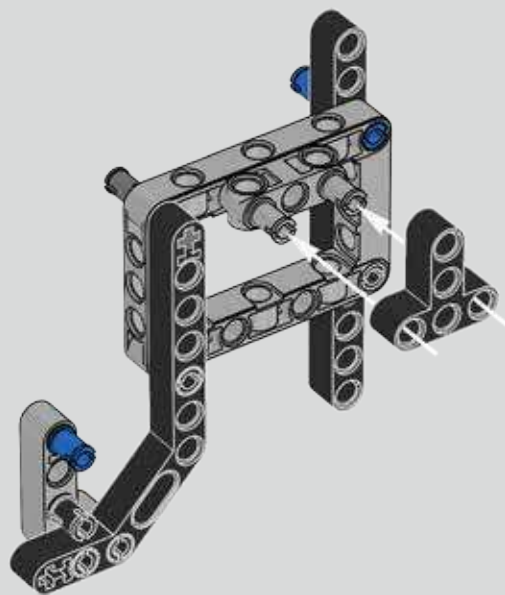

459

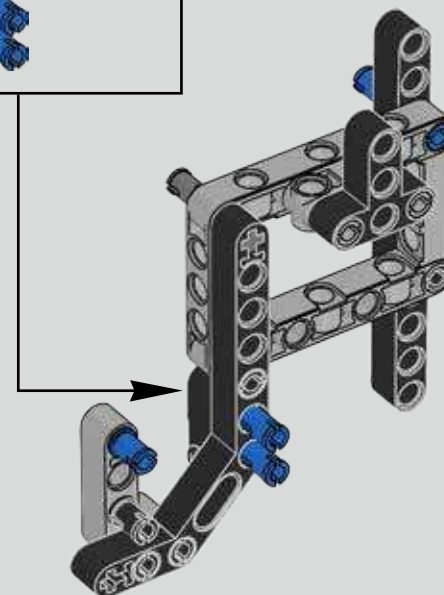
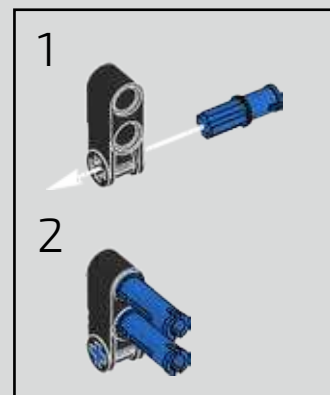



460

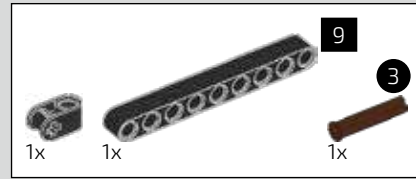
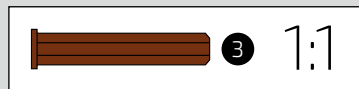
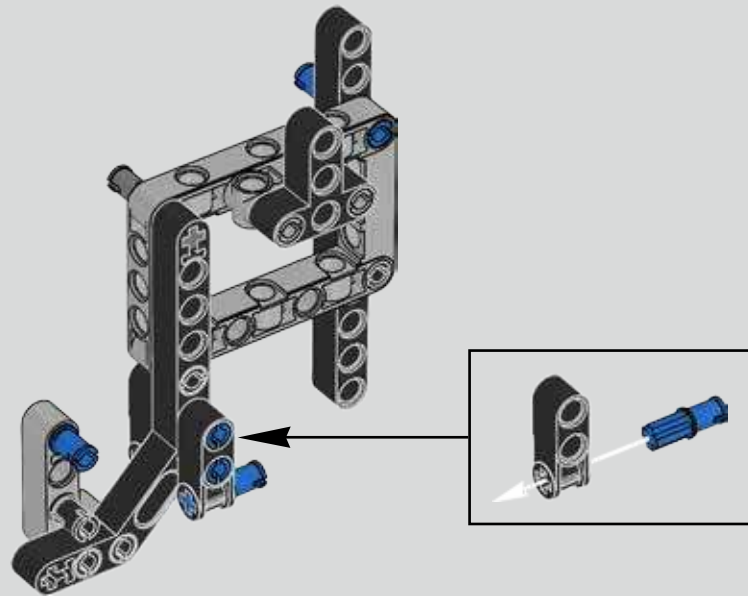

461

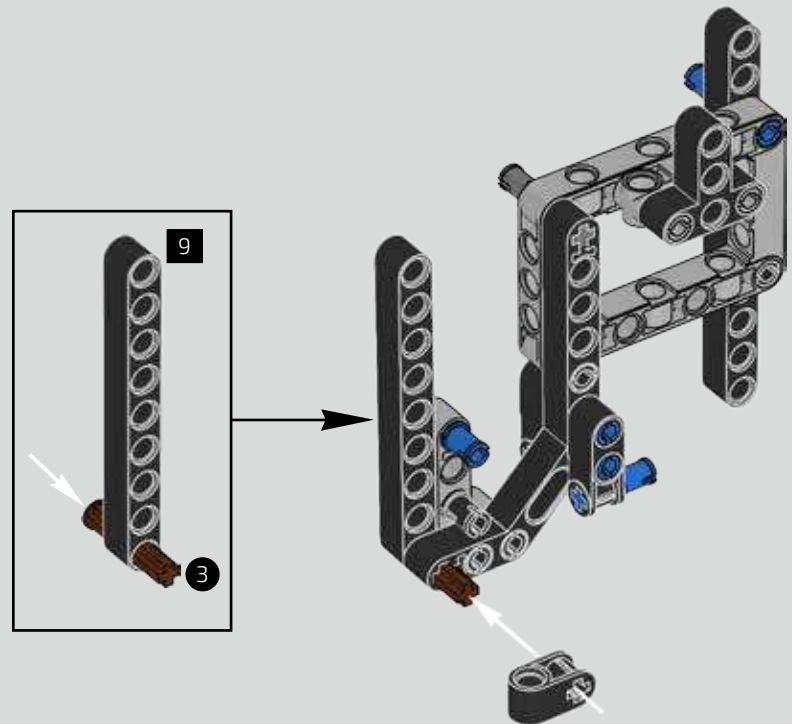

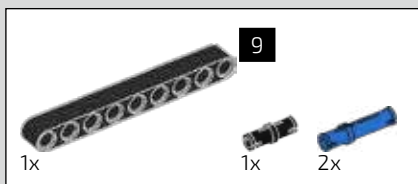

462

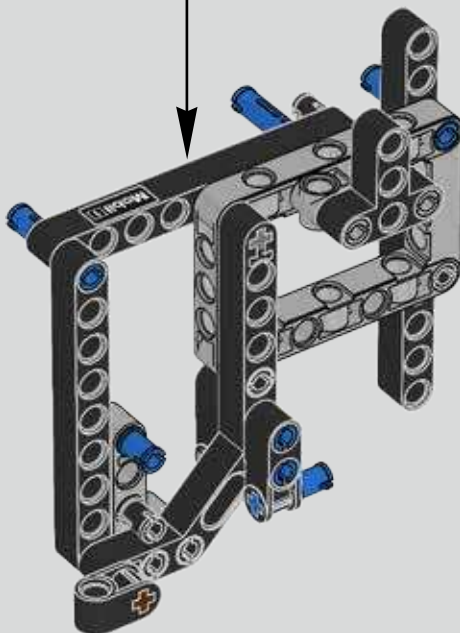
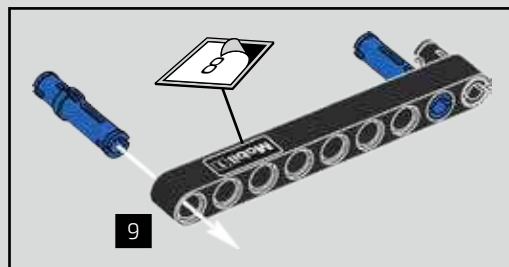

463

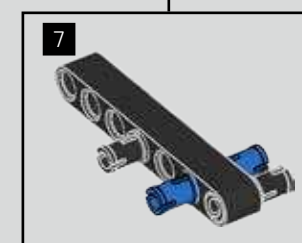
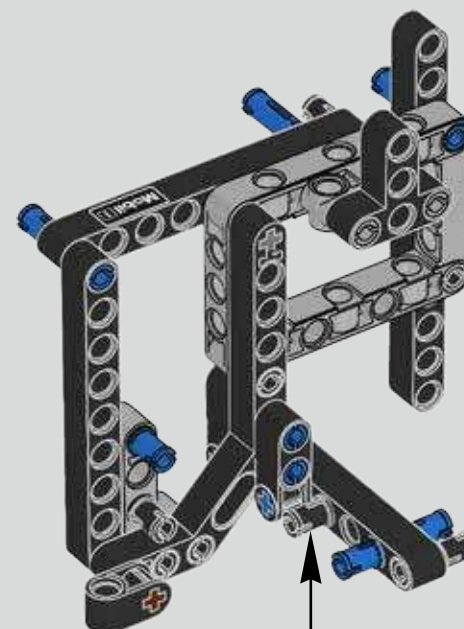

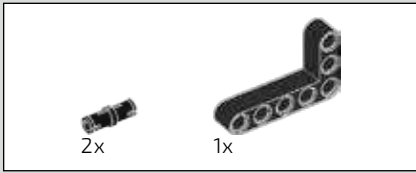

464

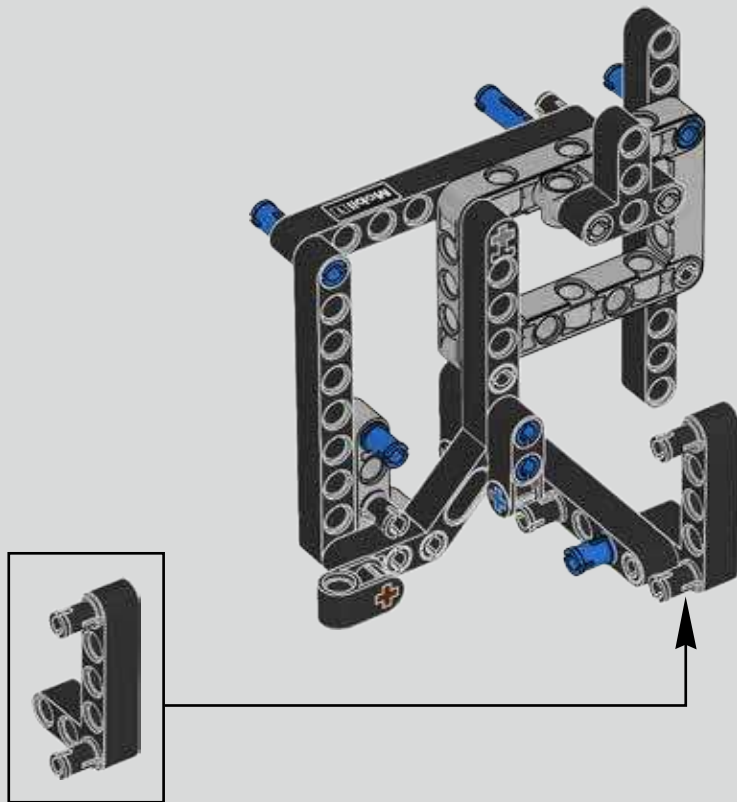

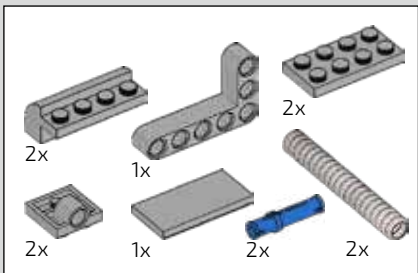
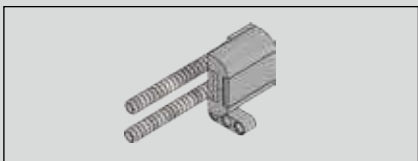

465

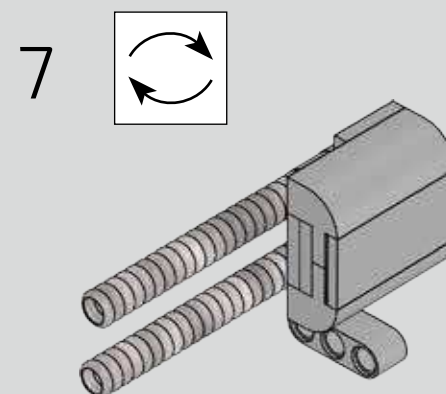
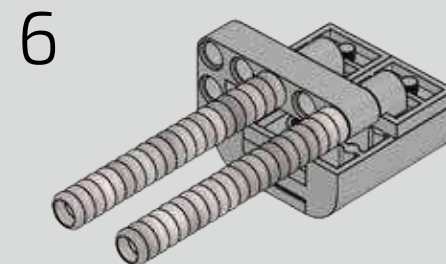
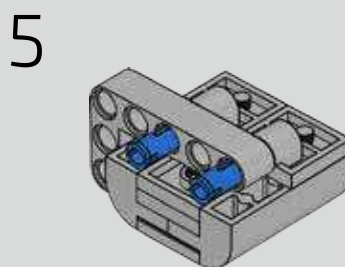
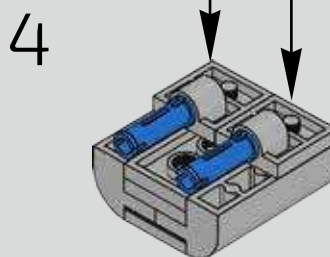
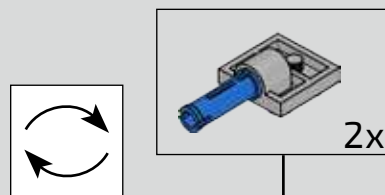
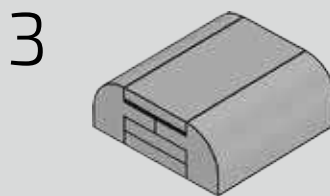
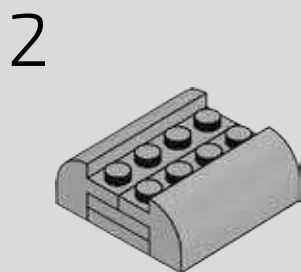
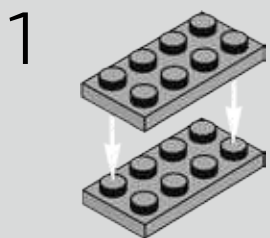

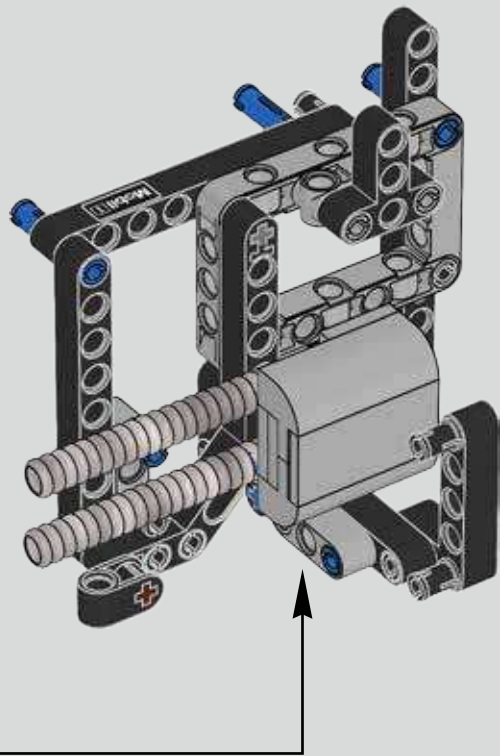

466

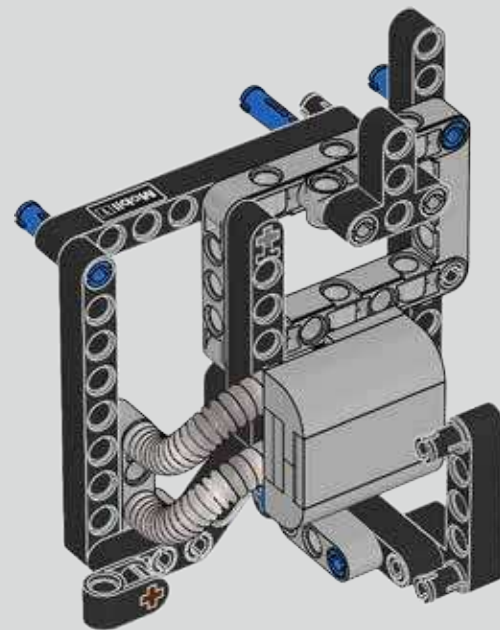

467

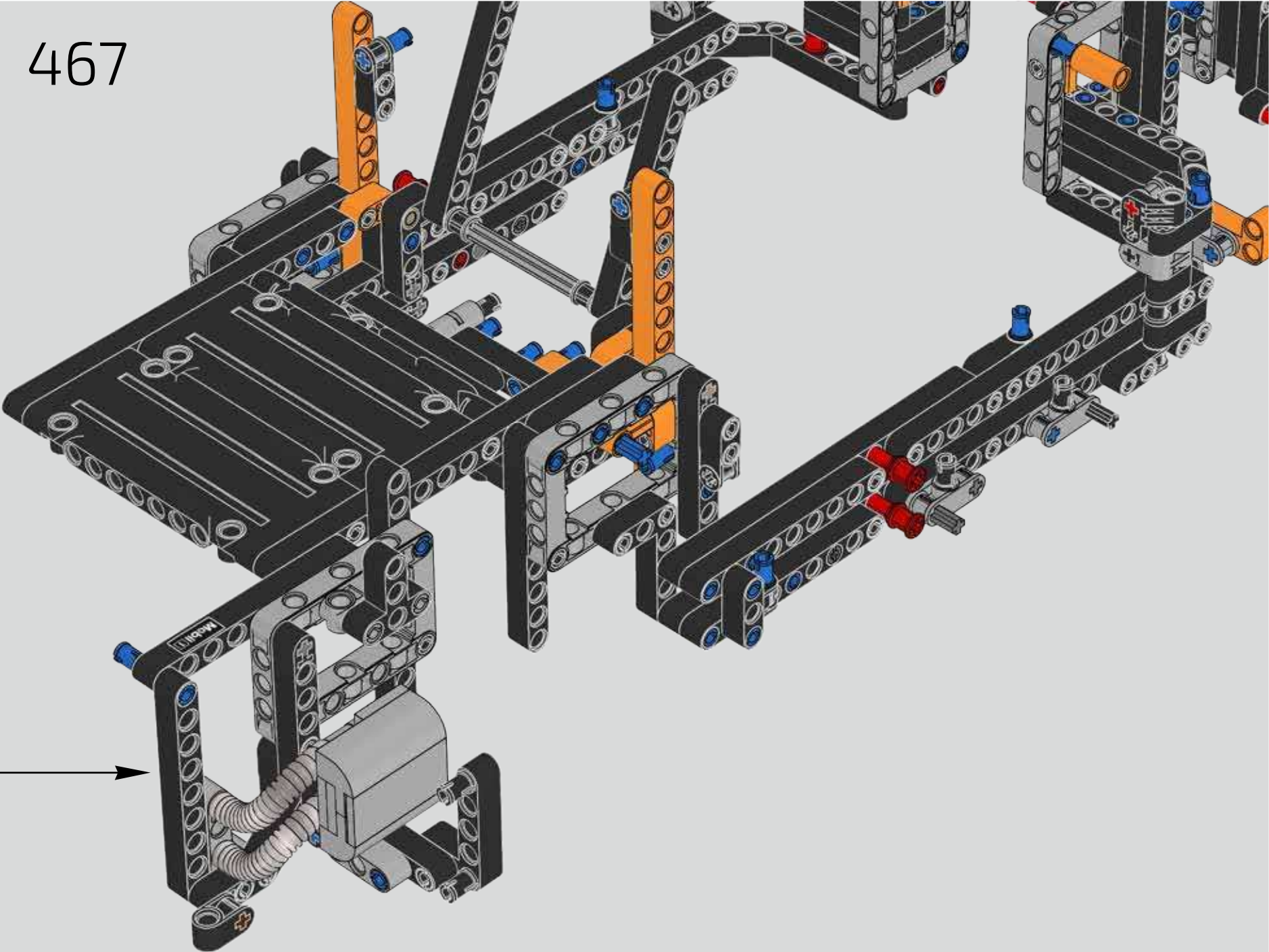

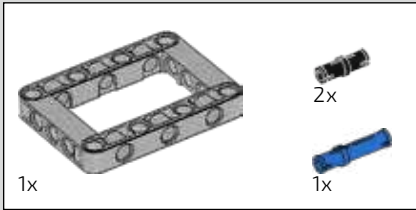
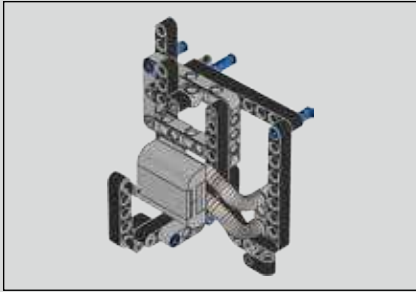

468

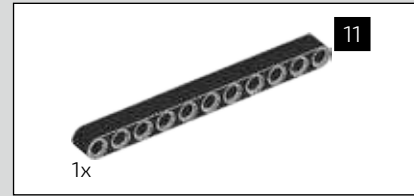
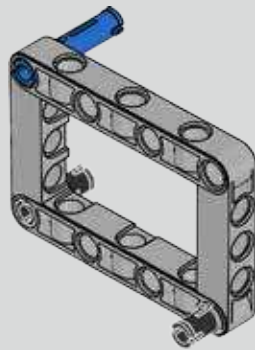

469

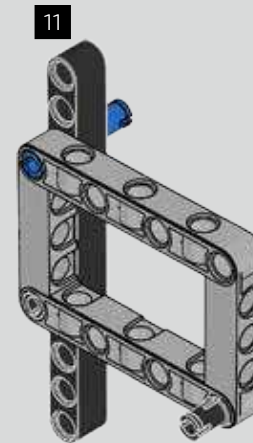

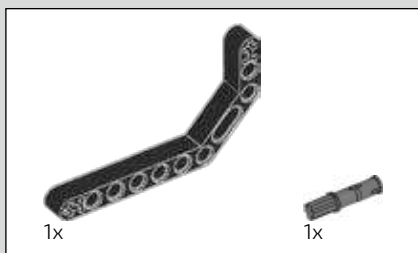

470

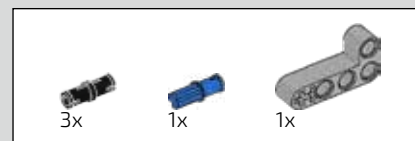
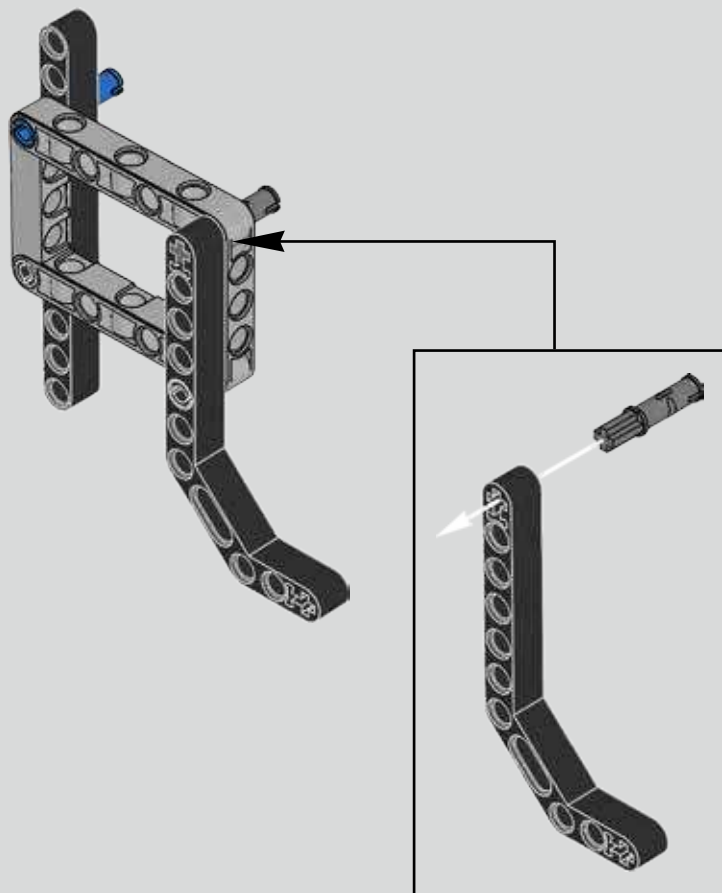

471

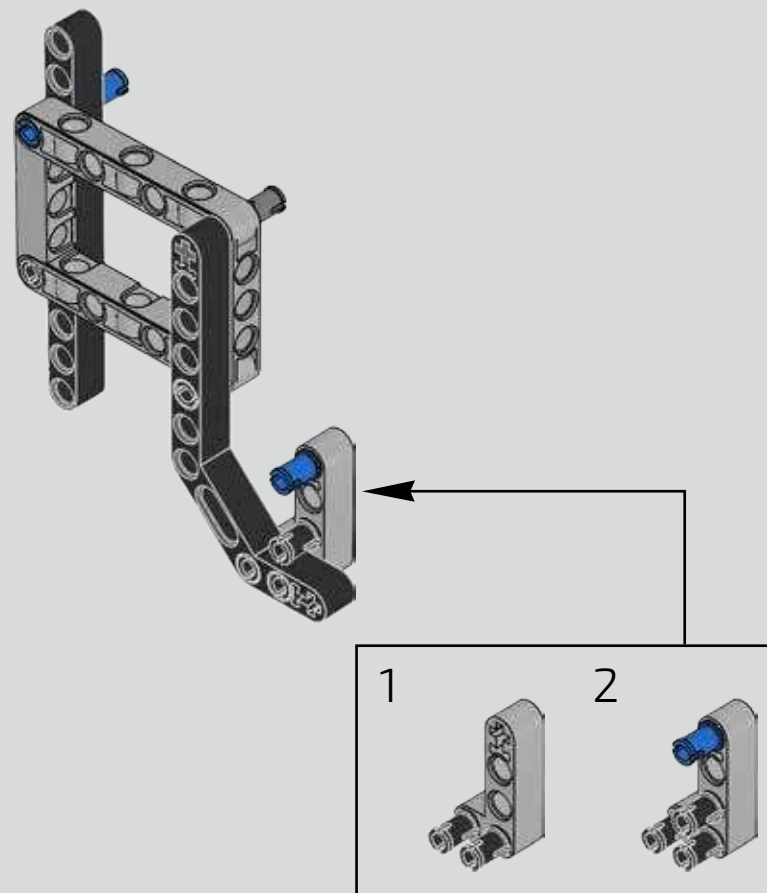

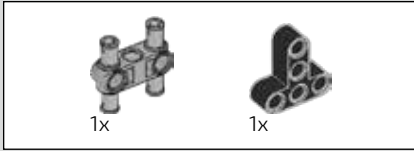

472

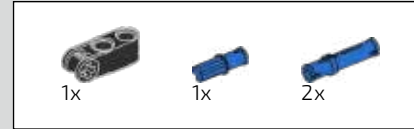
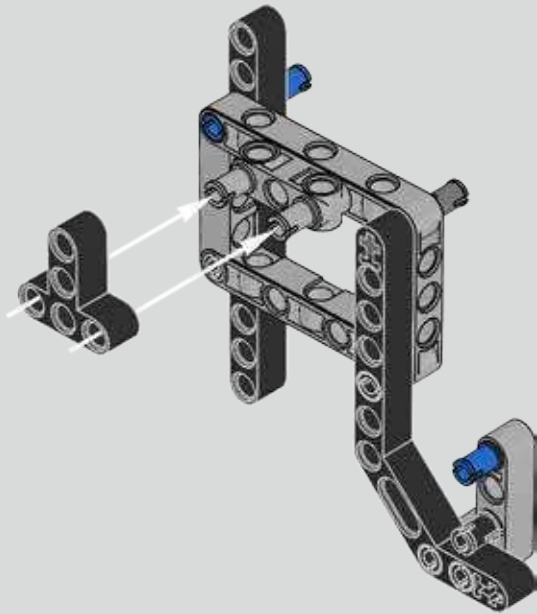

473

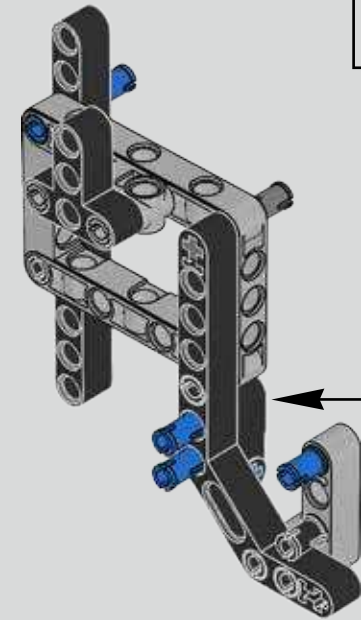
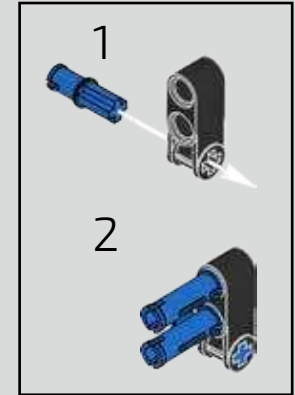



474

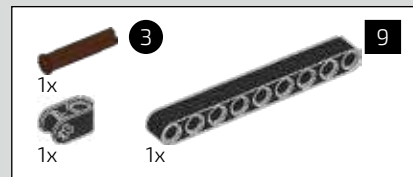
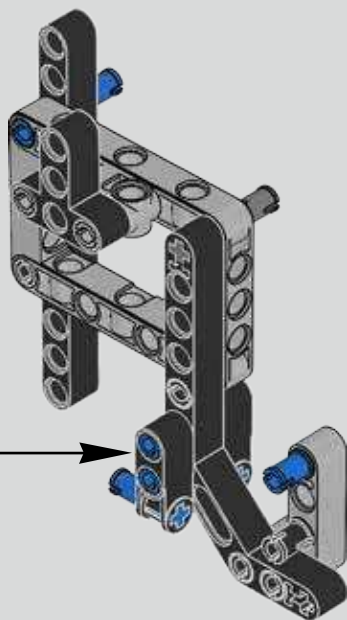
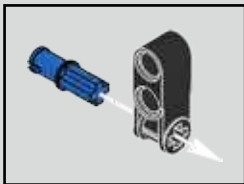

475

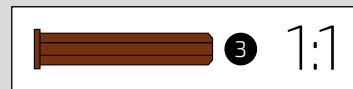
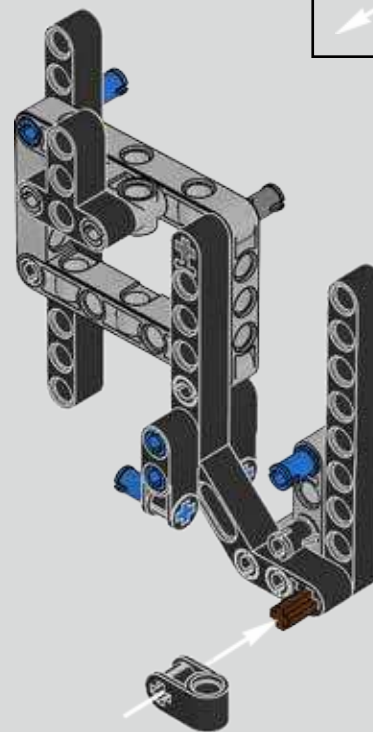
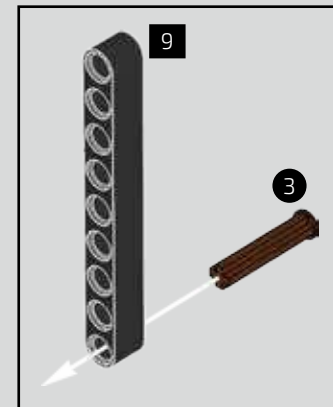

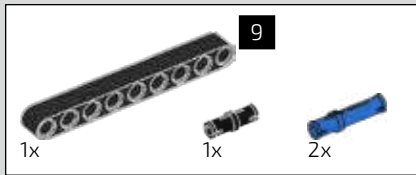

476

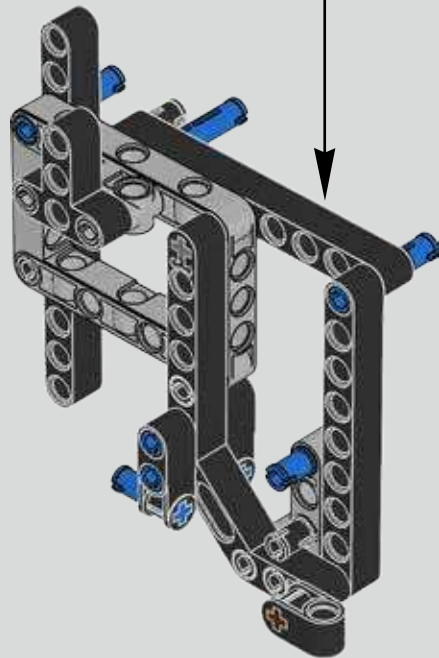
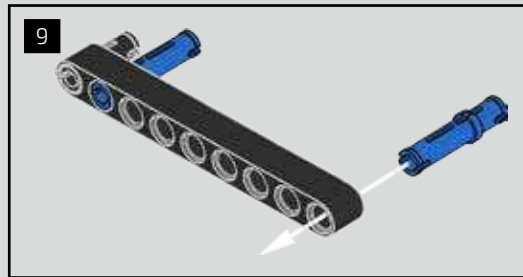

477

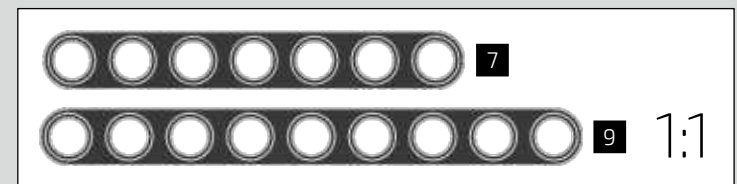
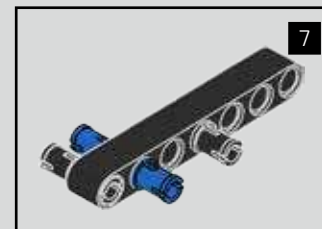
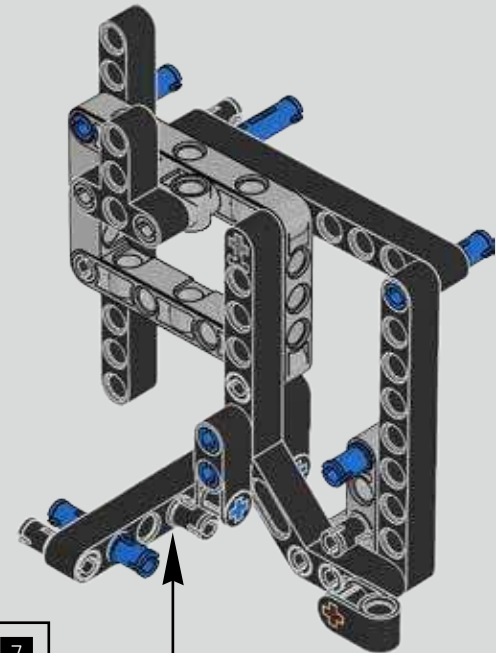

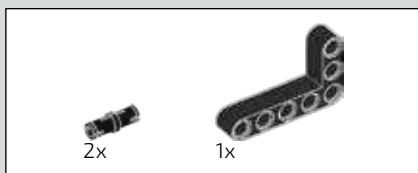

478

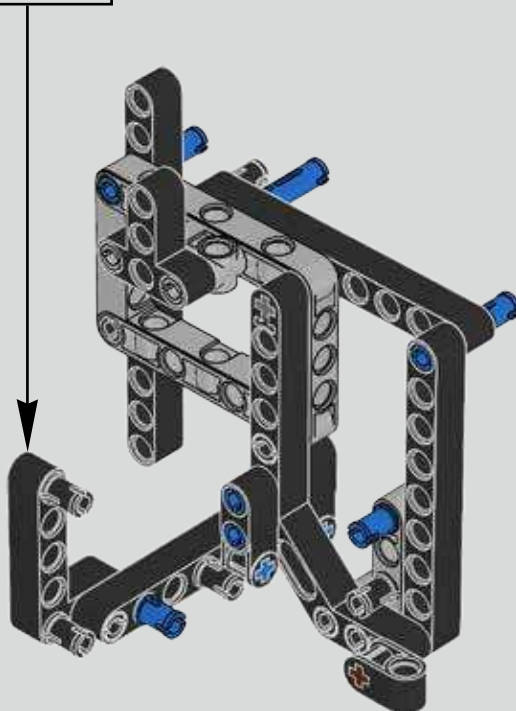
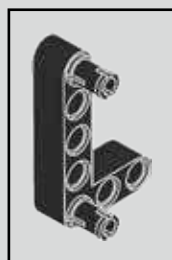

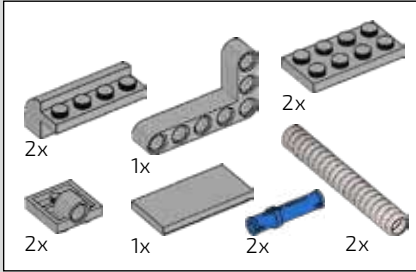
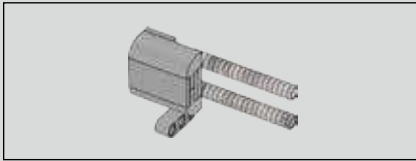

479

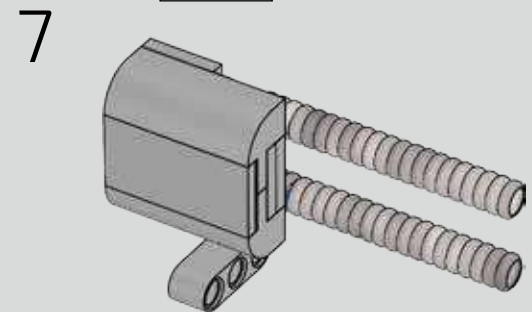
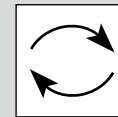
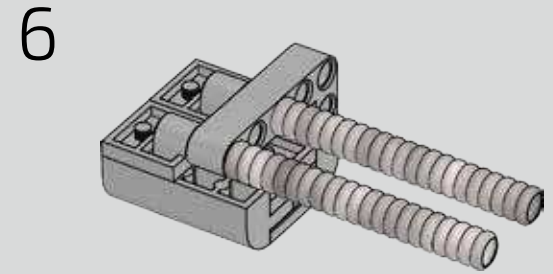
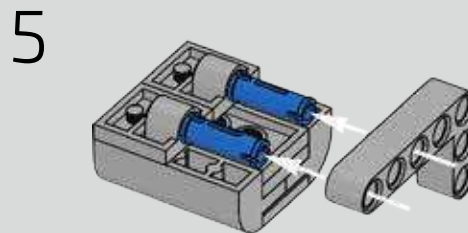
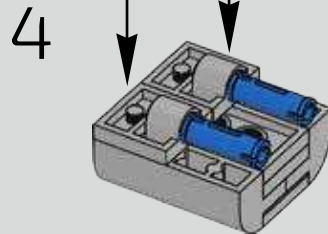
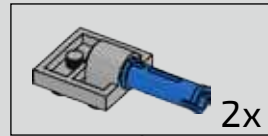
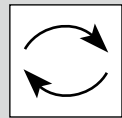
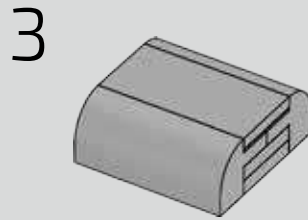
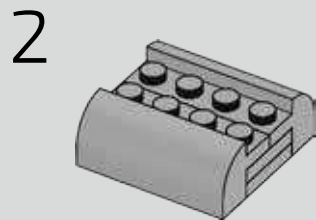
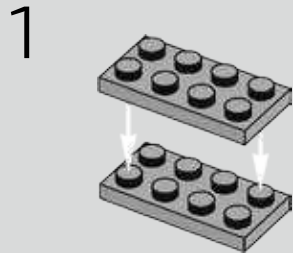

480

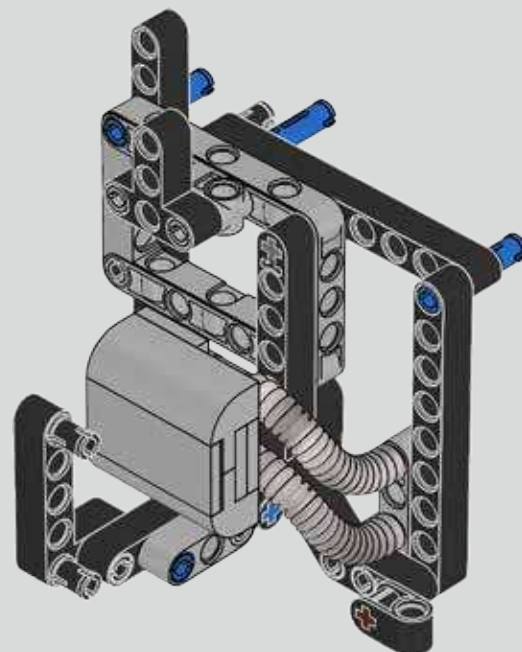
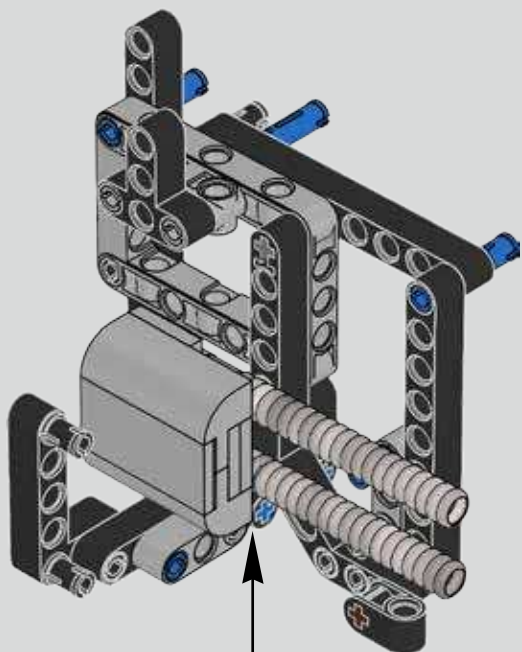

481

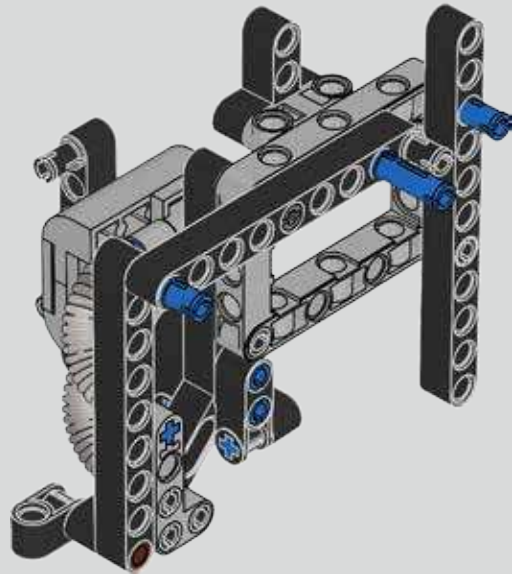
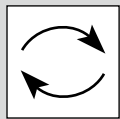

482

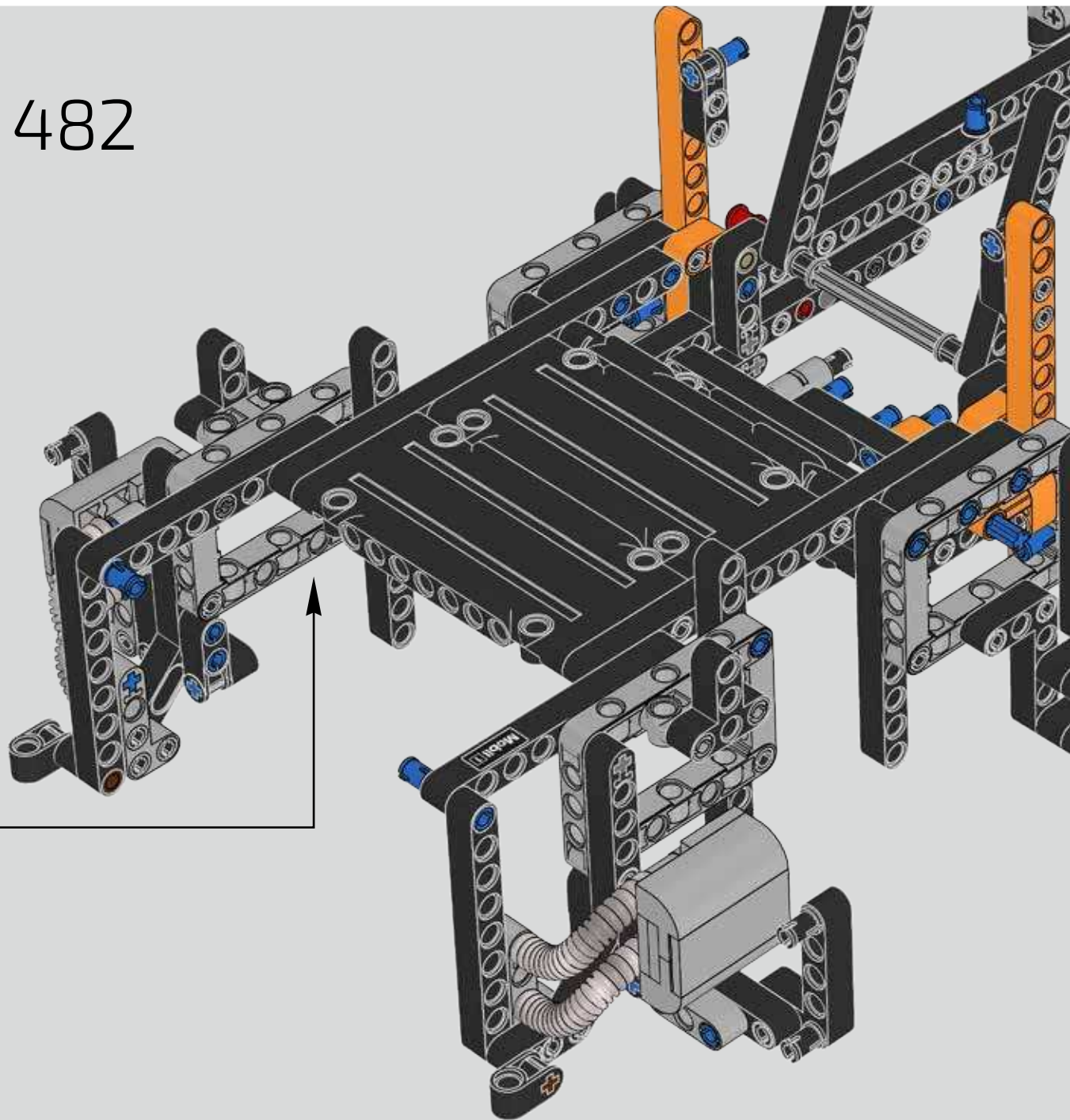

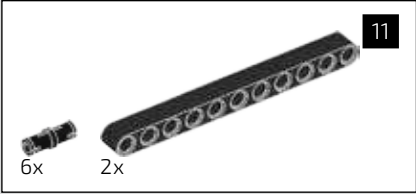

483

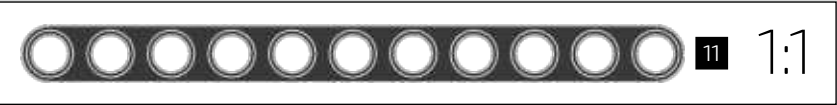
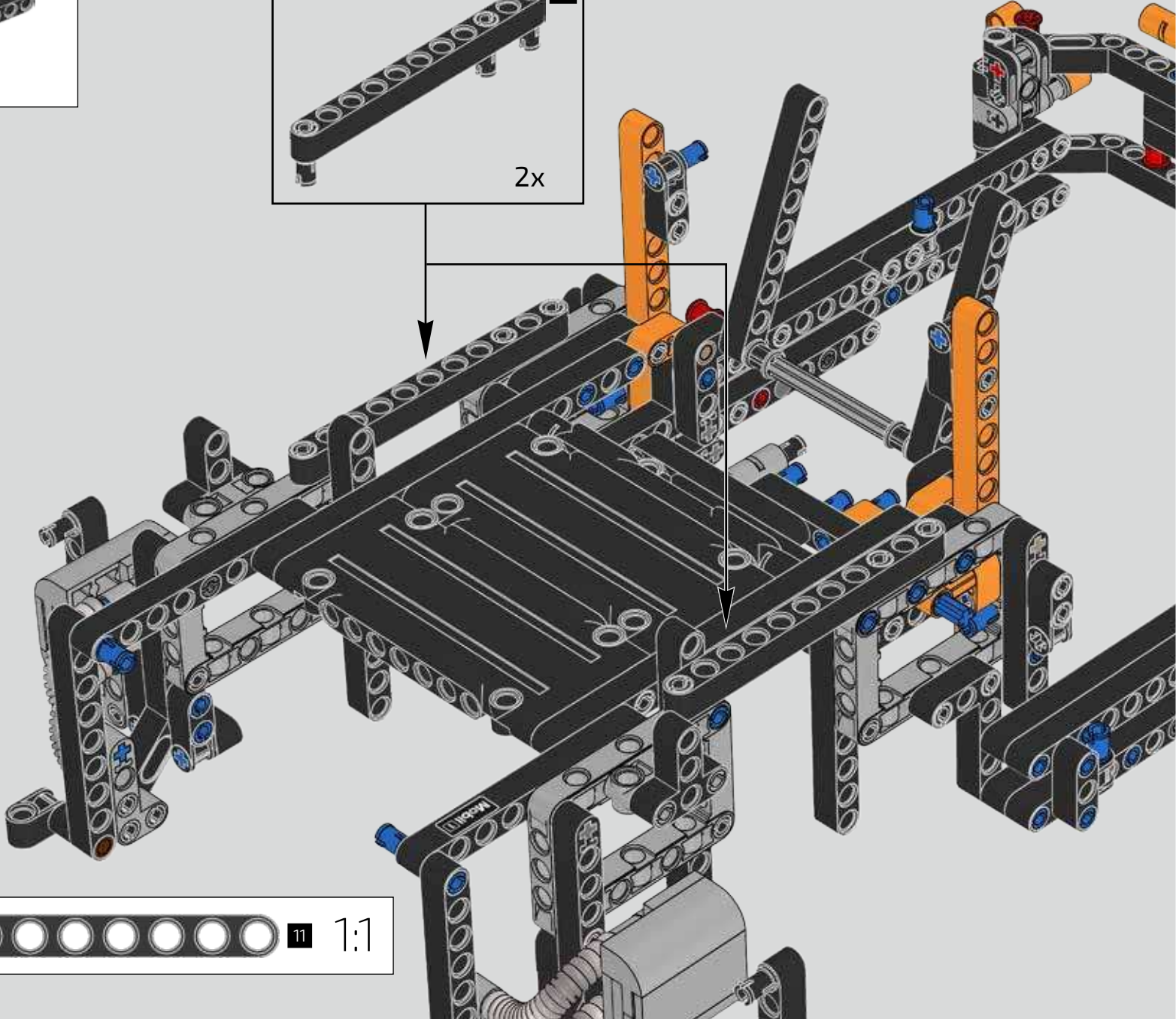
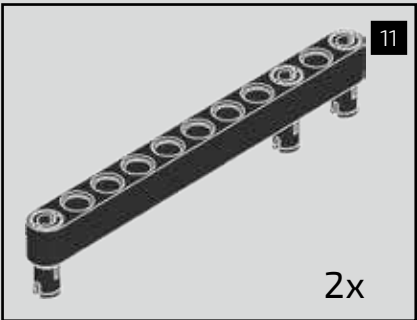

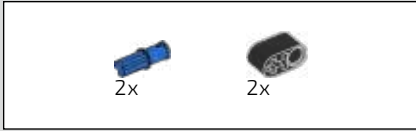

484

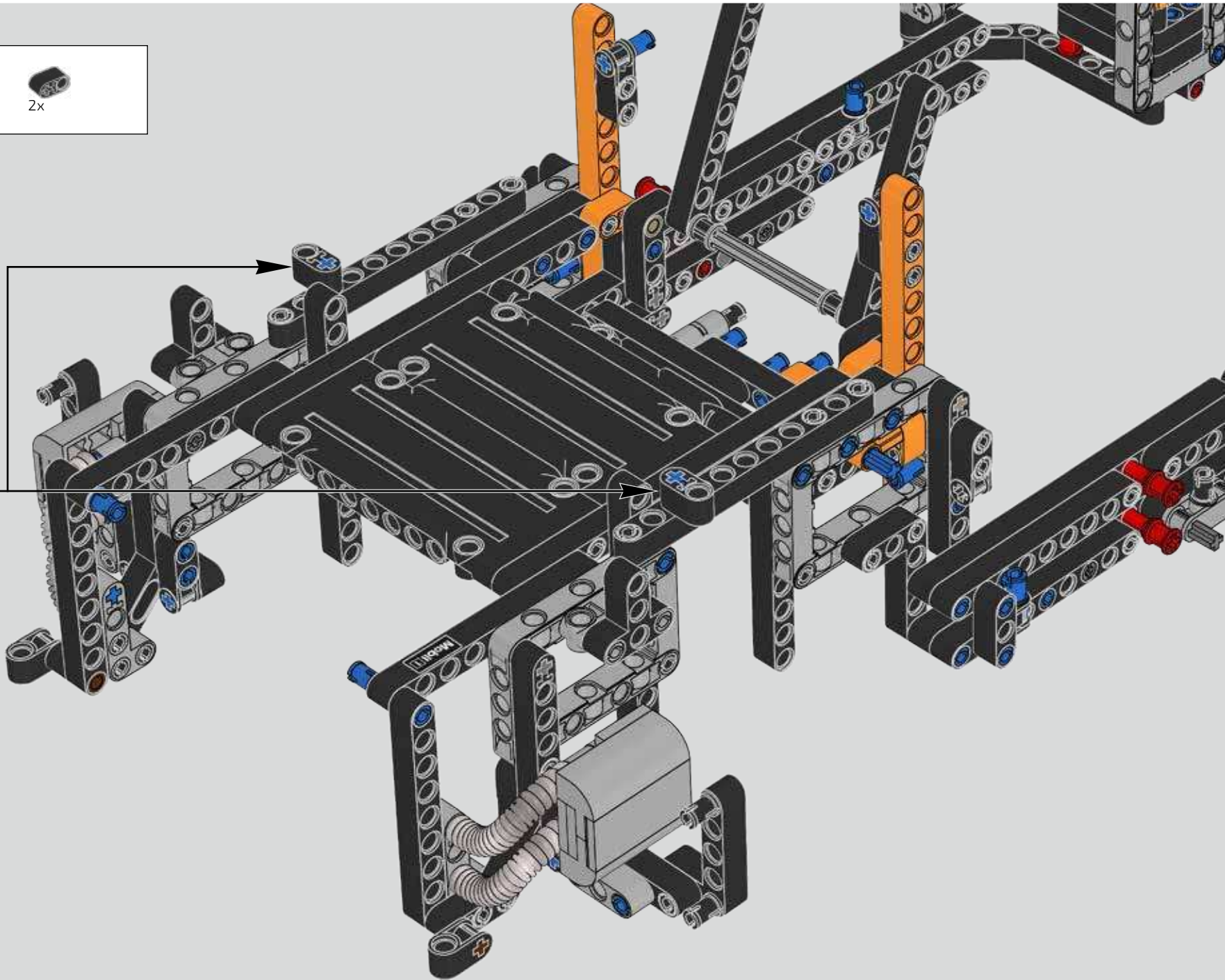
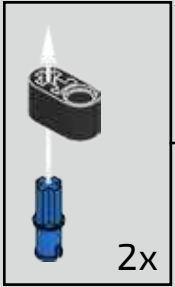

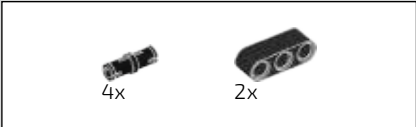

485

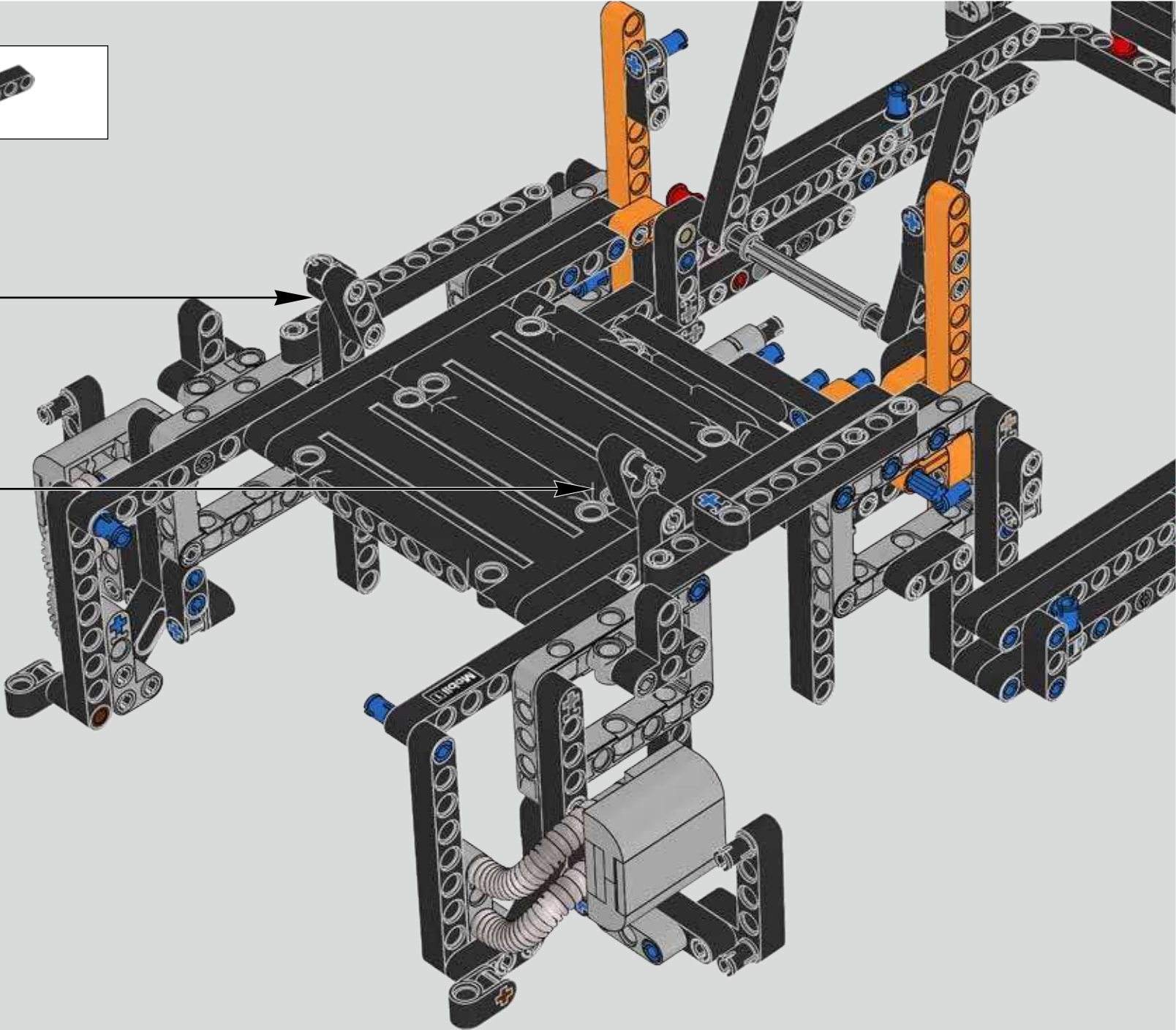
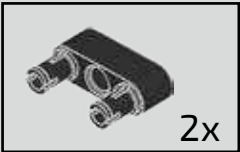



486

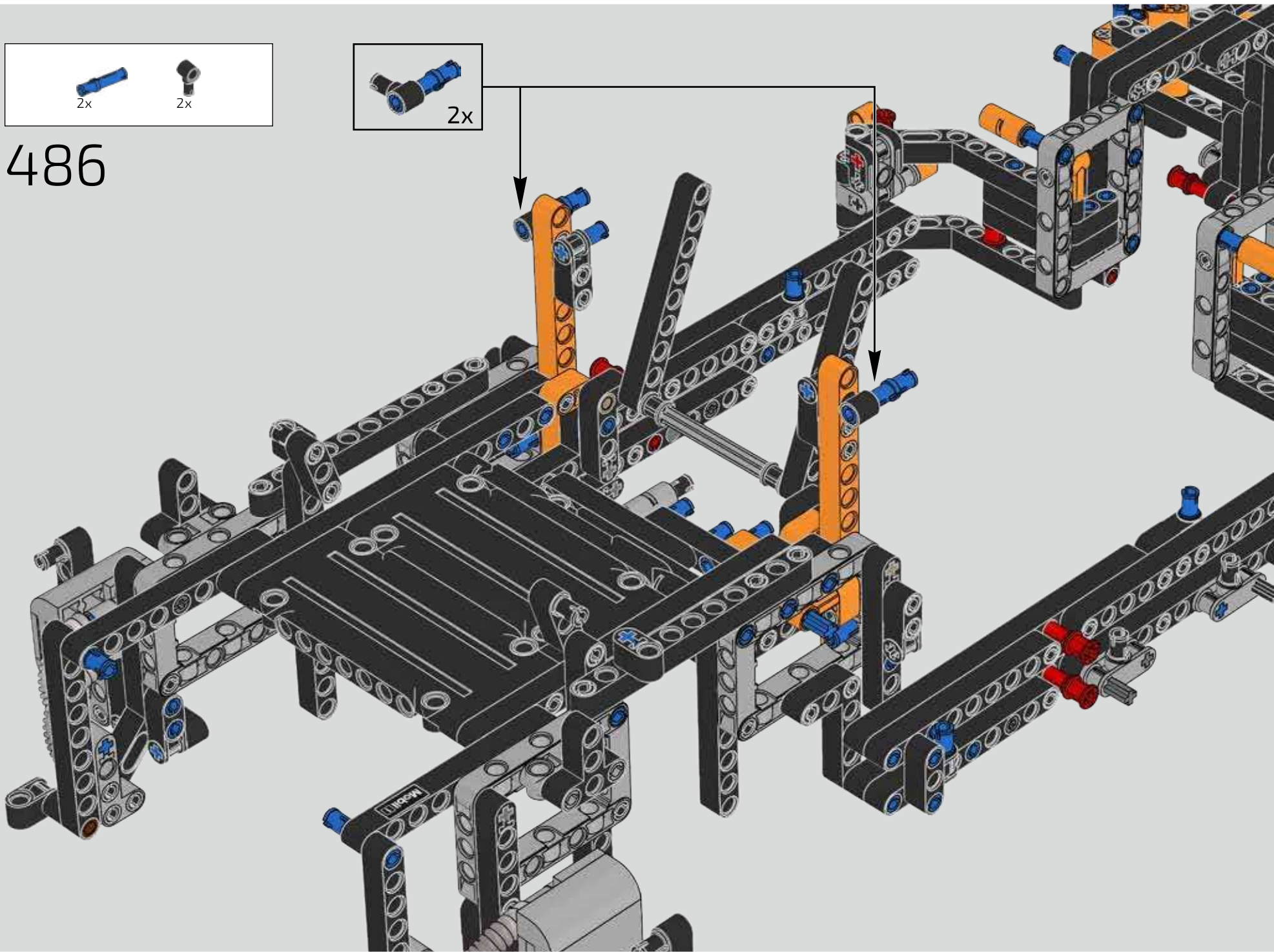

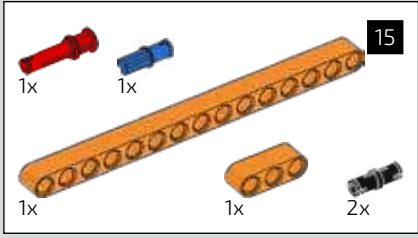

487

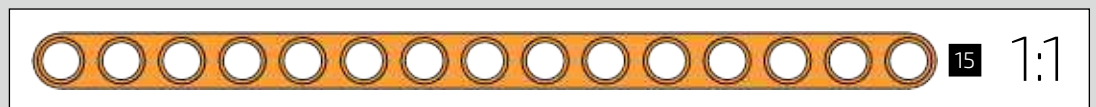
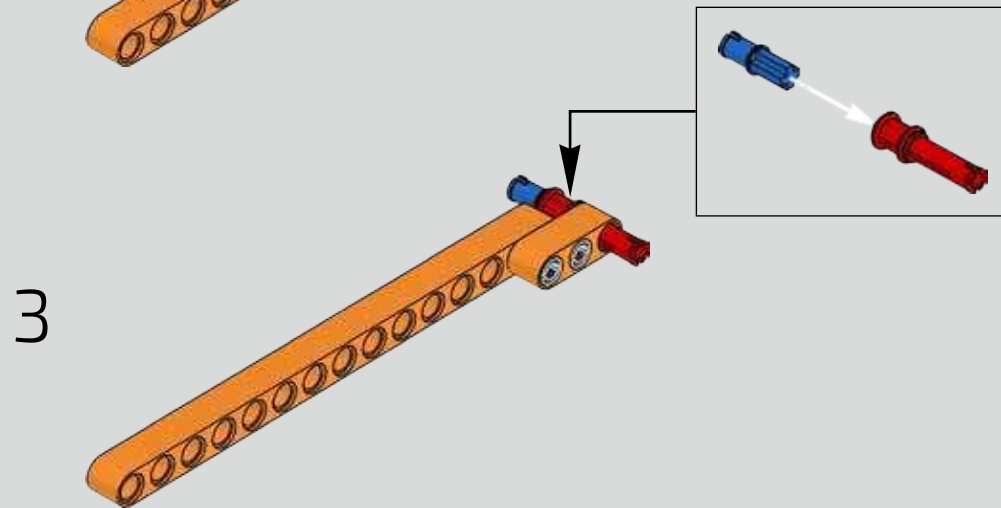
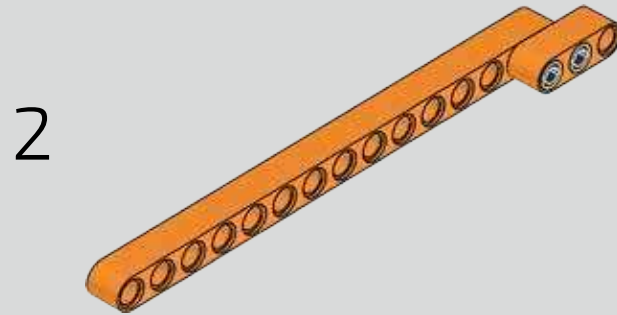
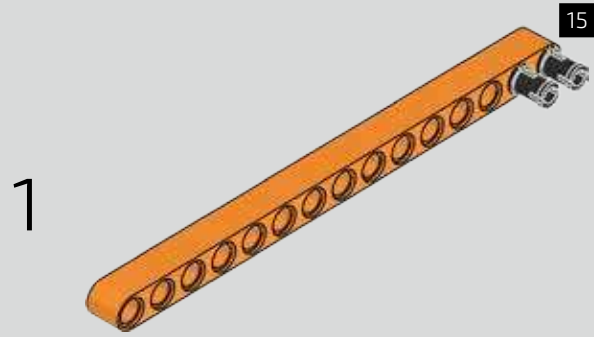

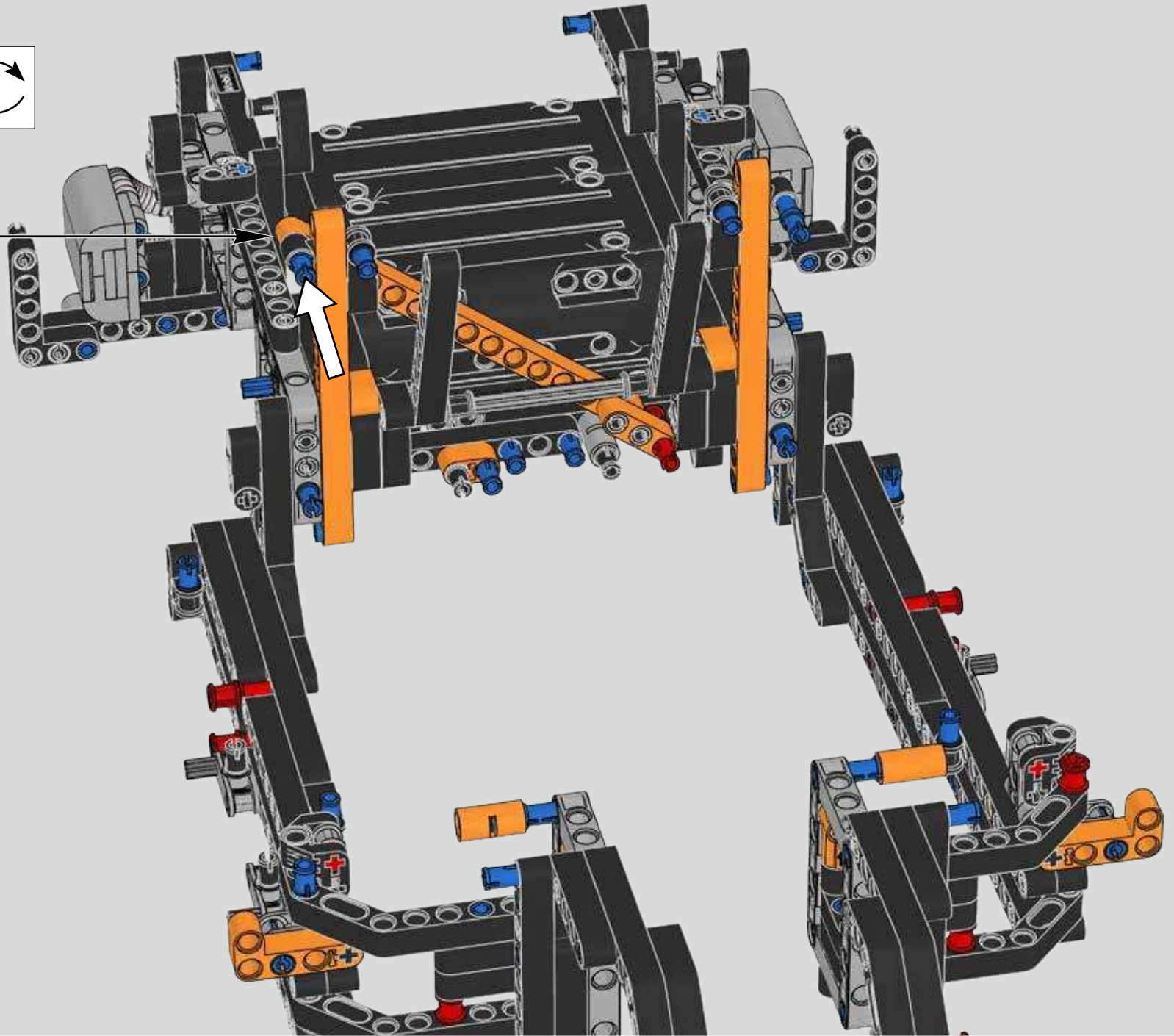
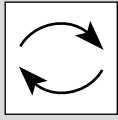

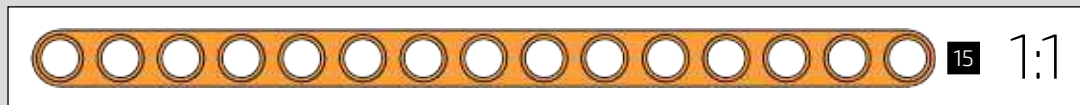
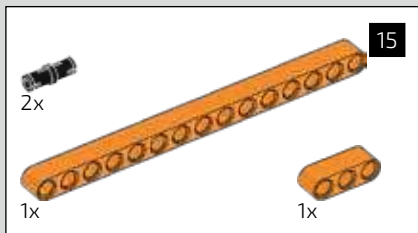

488

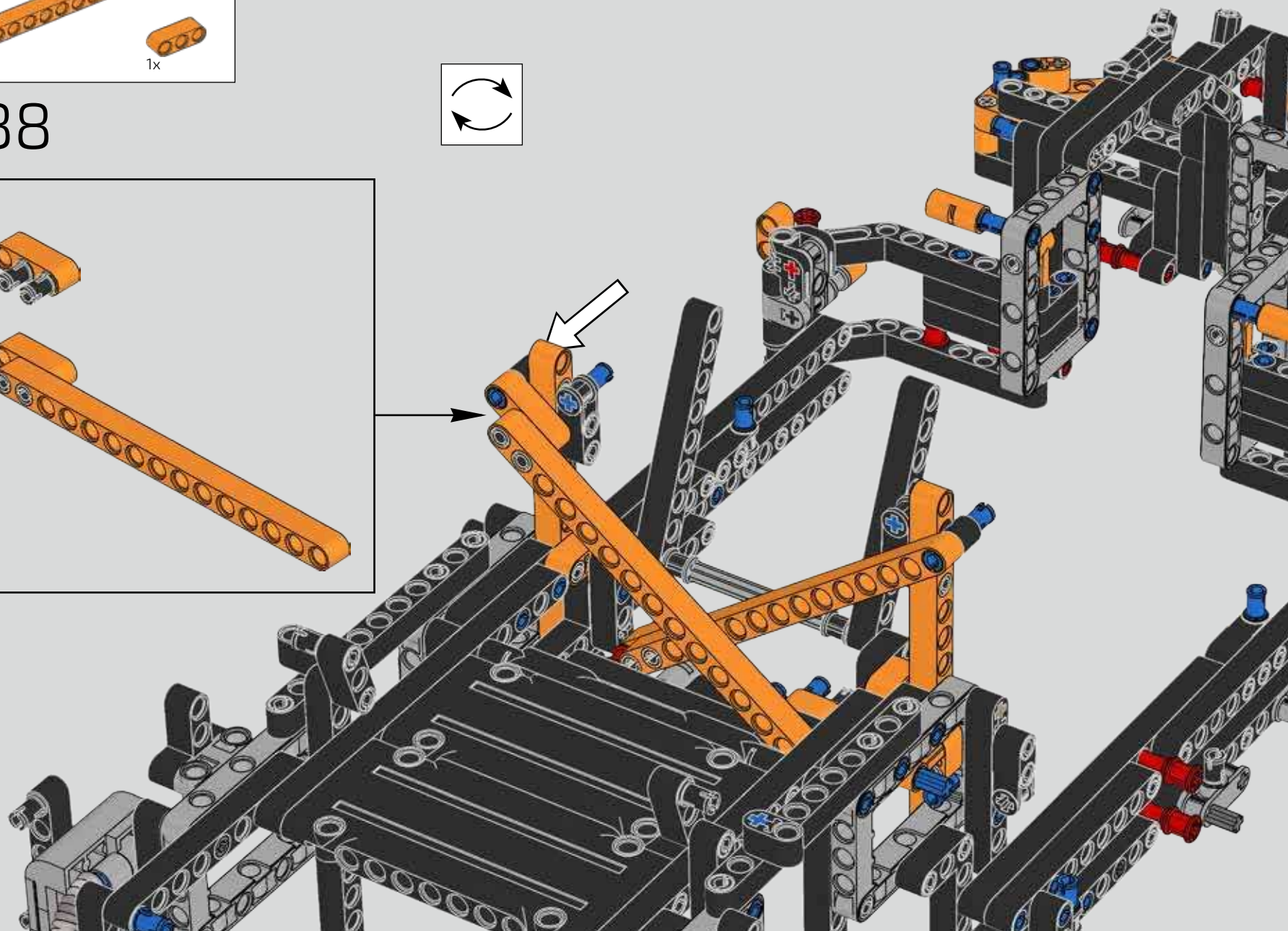
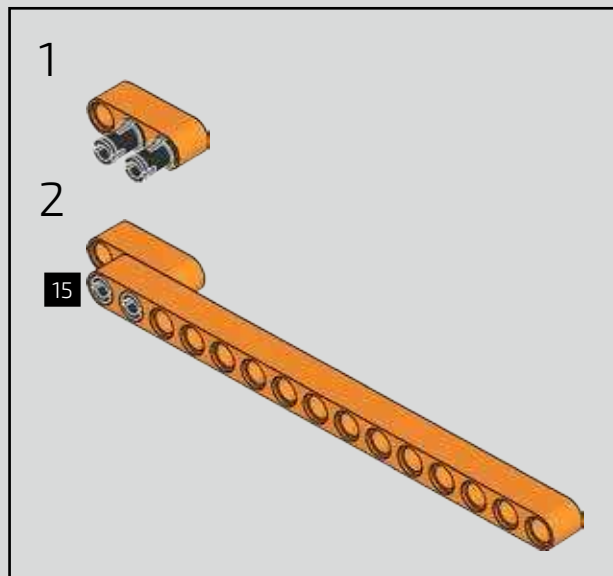
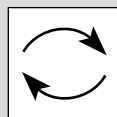

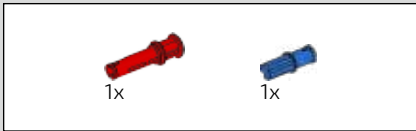

489

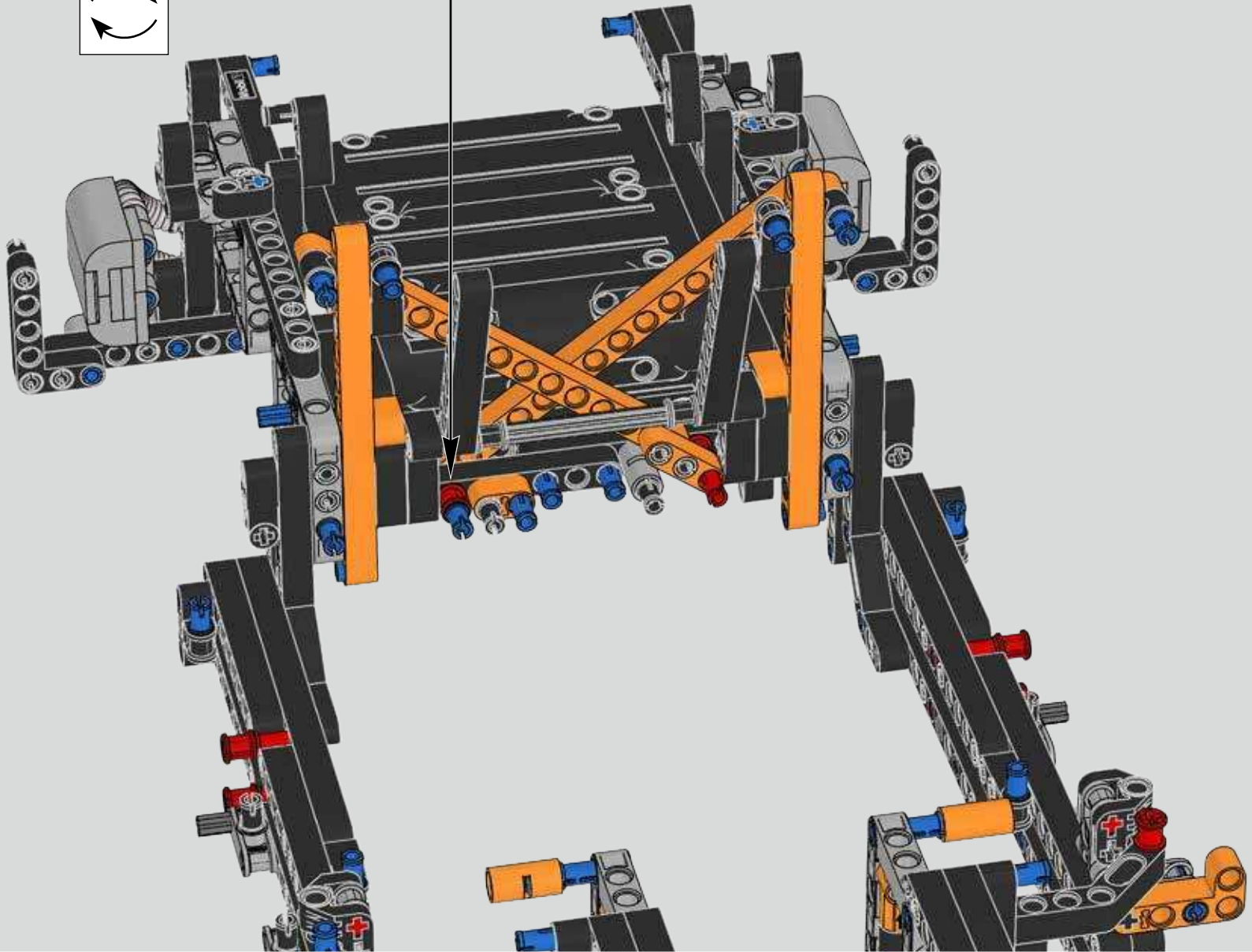
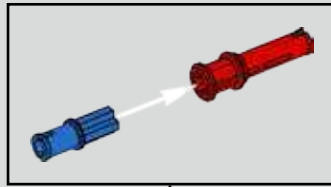
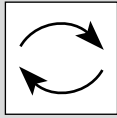

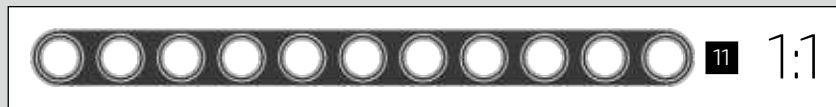
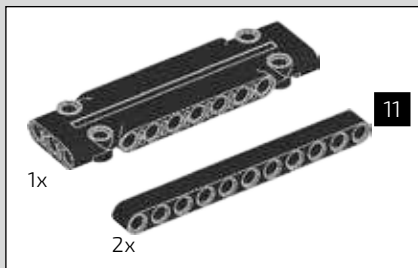

490

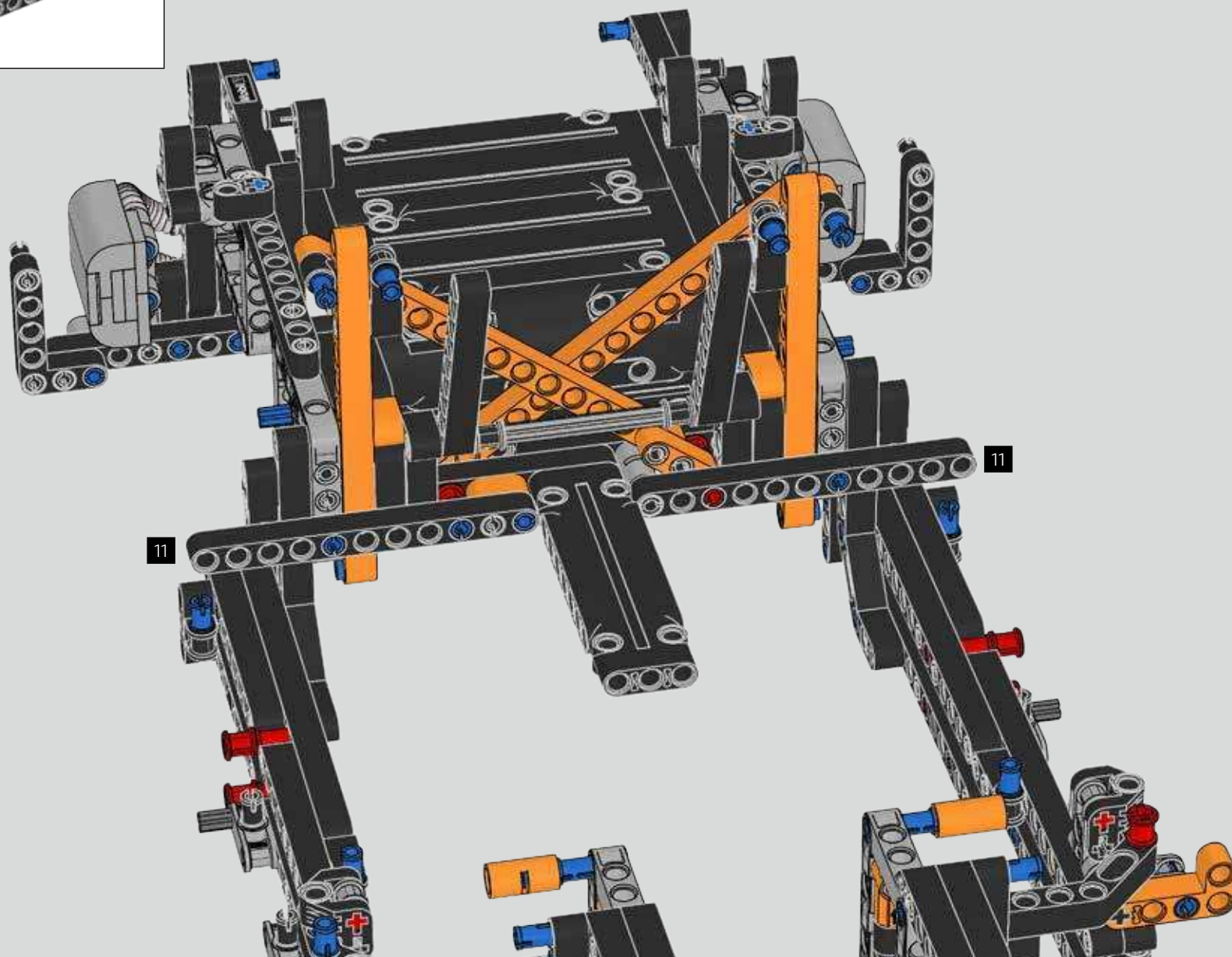



491

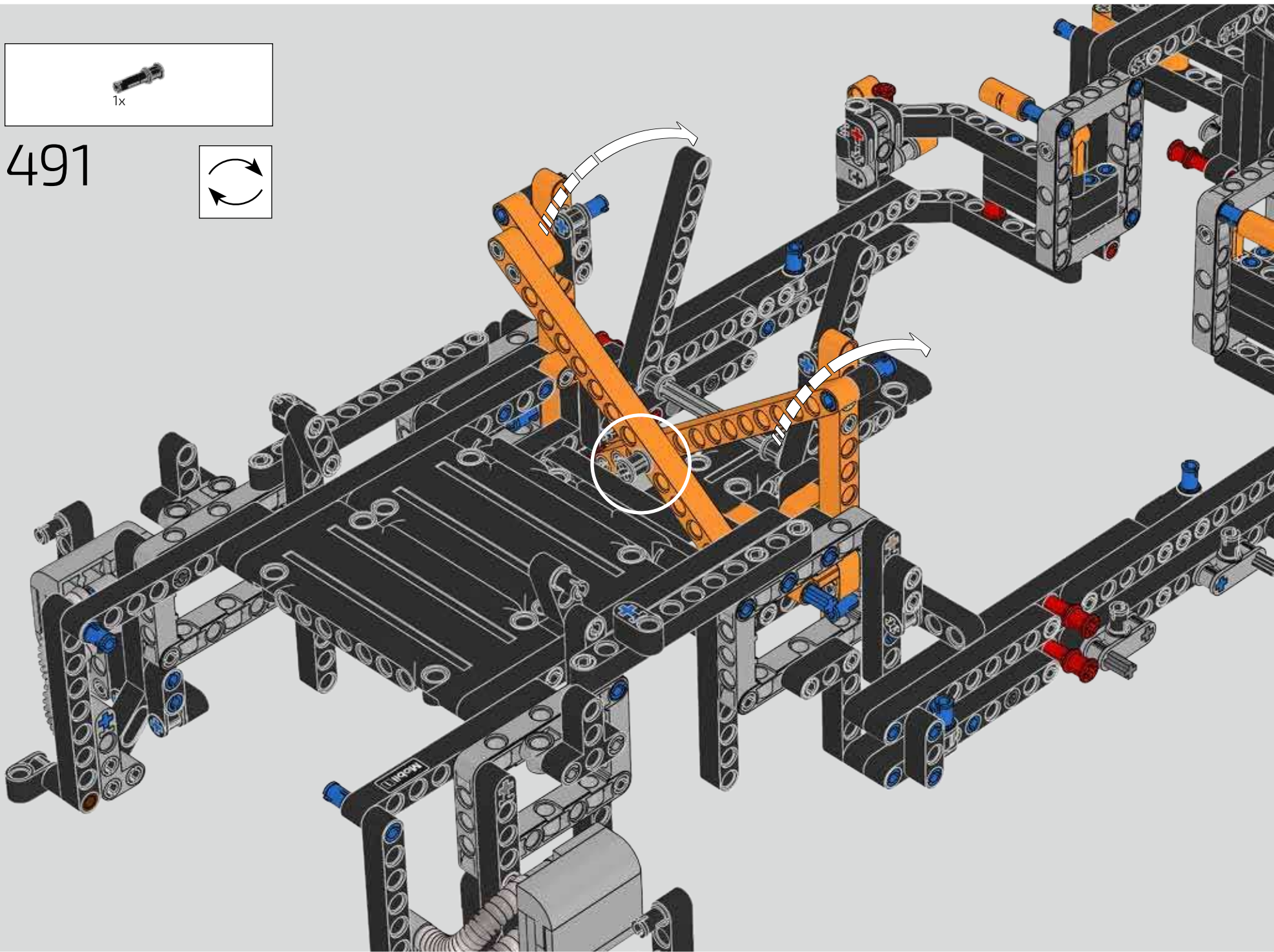
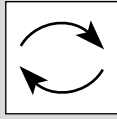

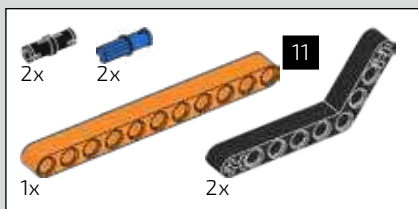

492

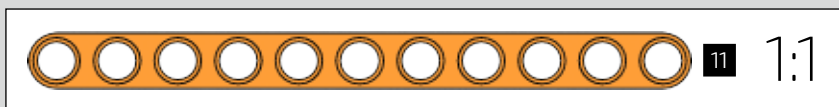
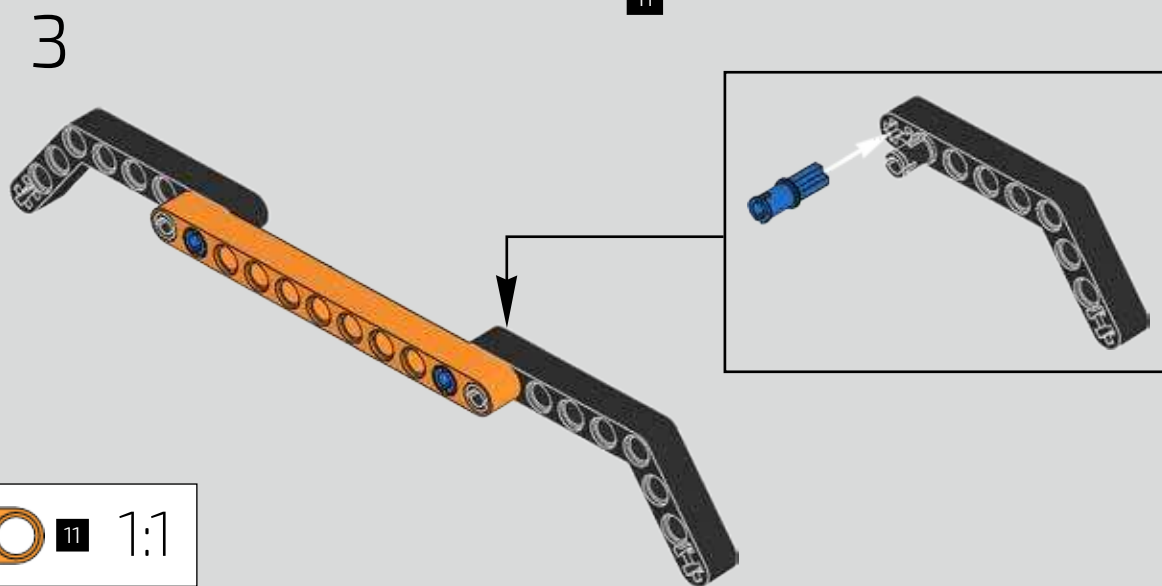
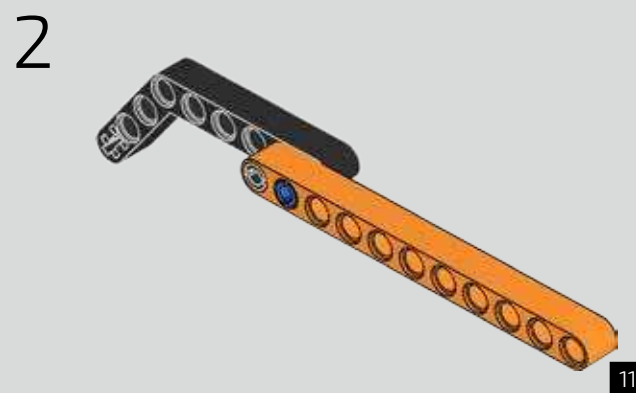
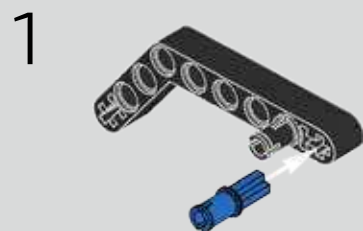

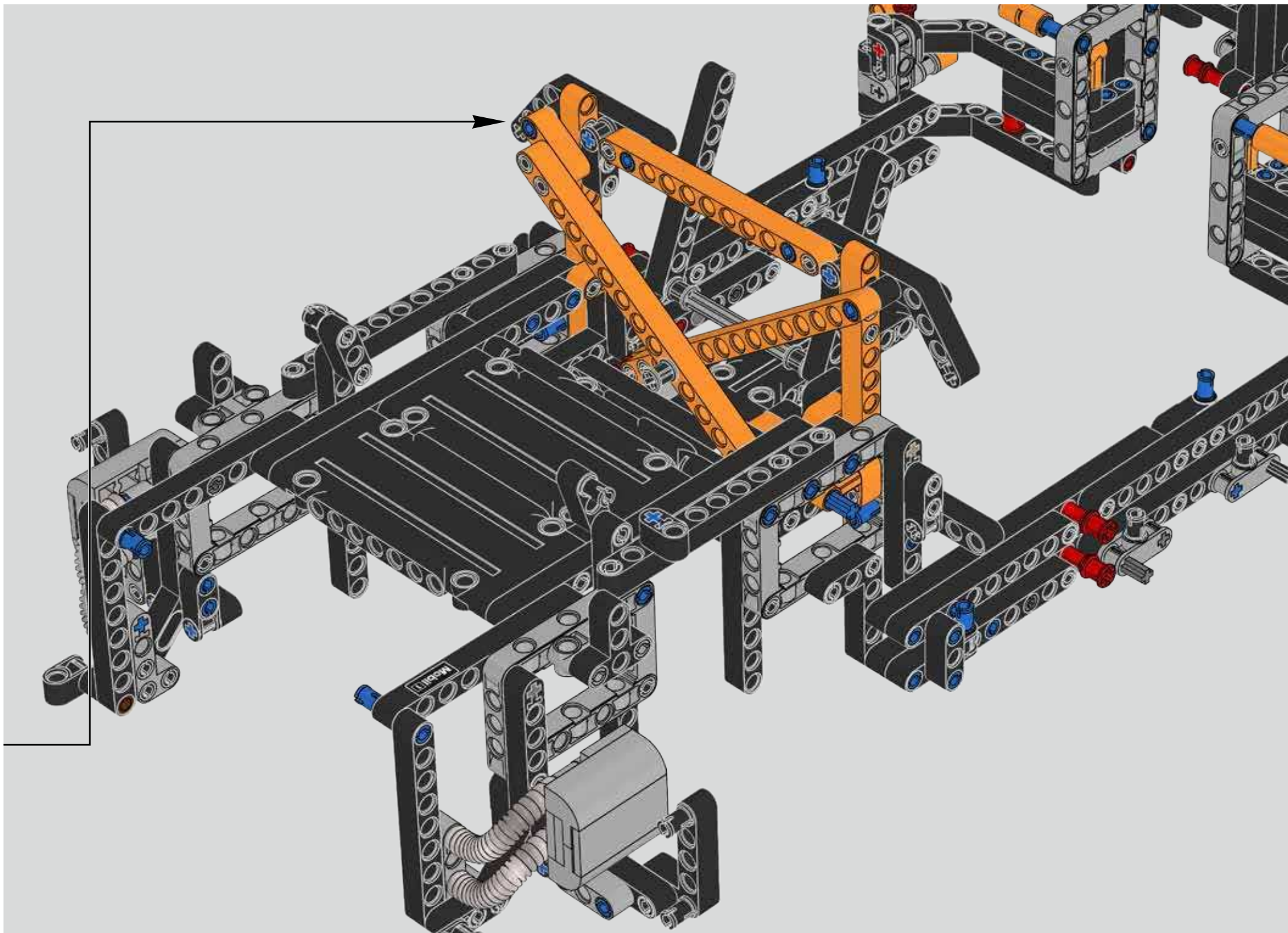

493

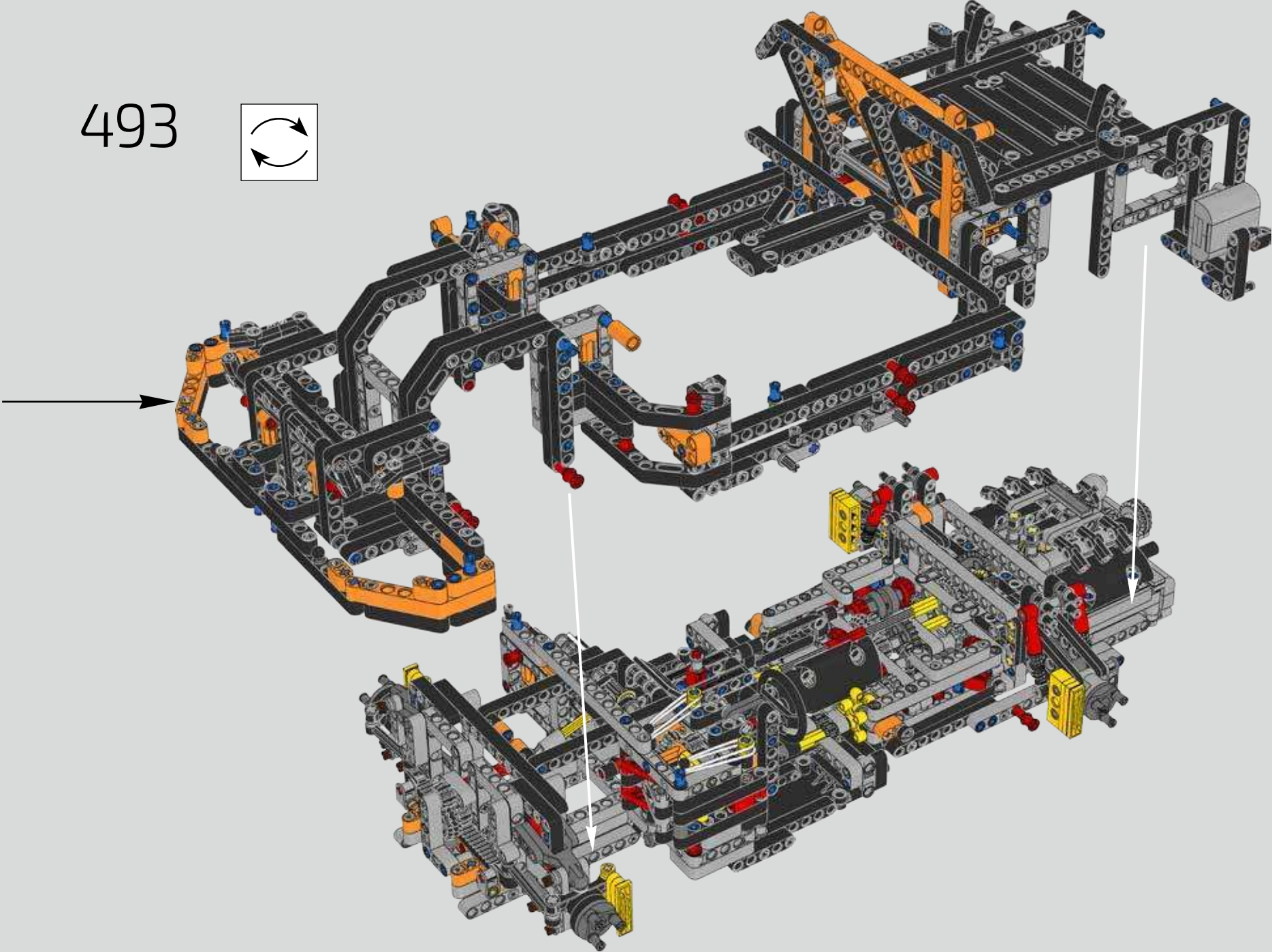
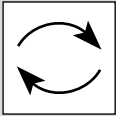



495

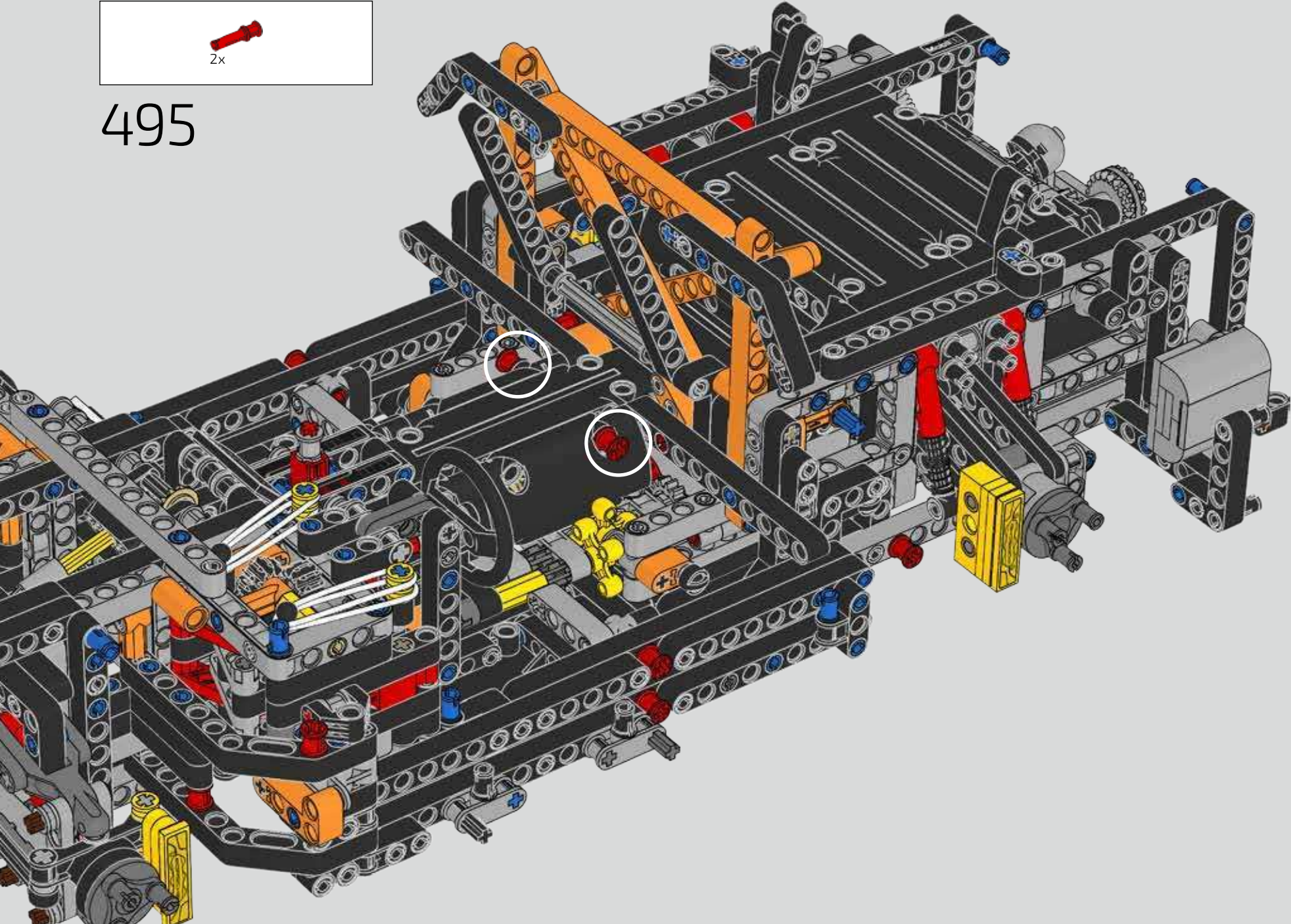

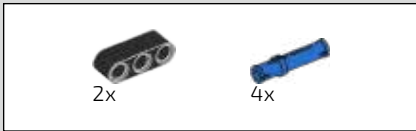

496

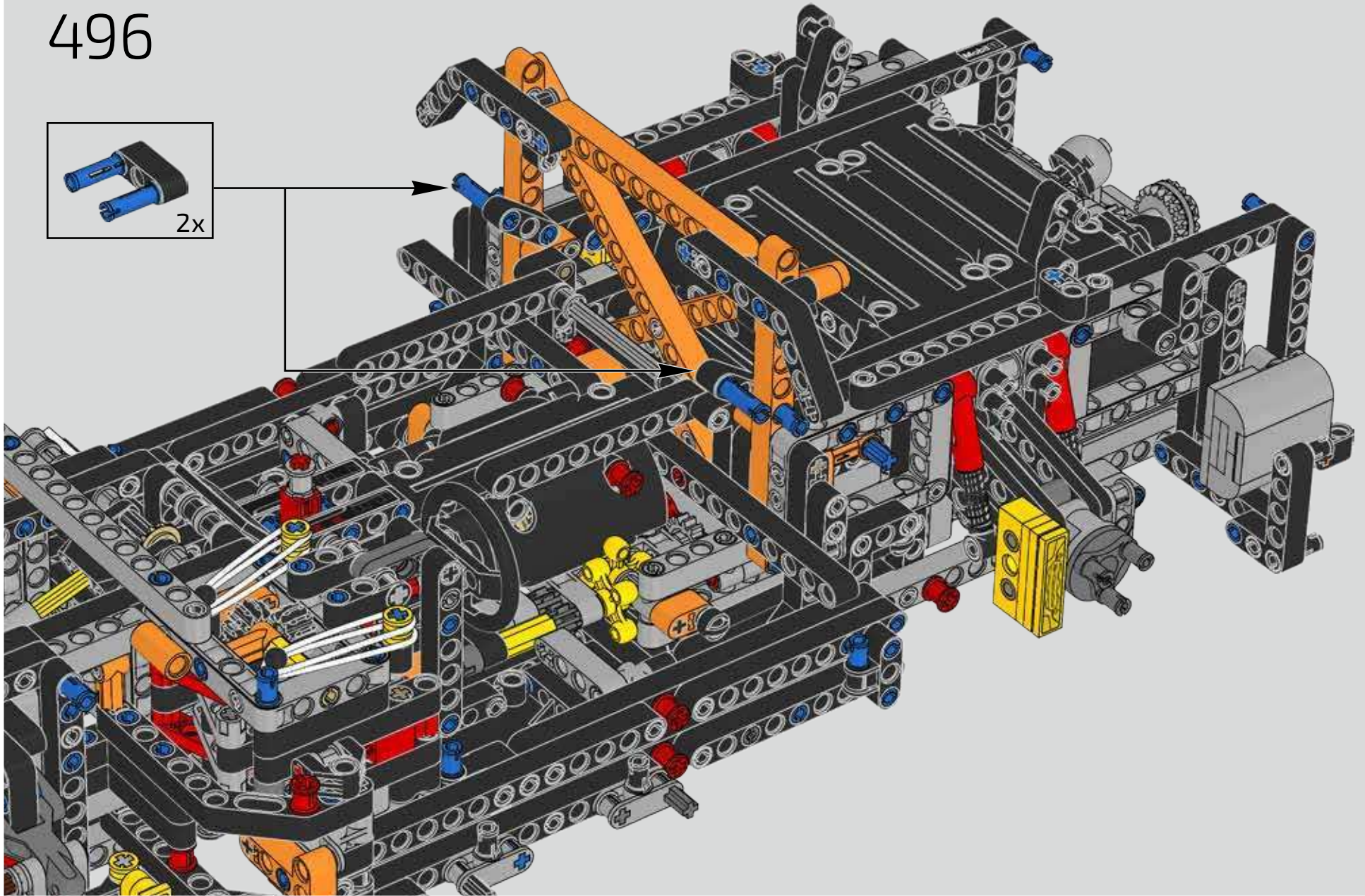
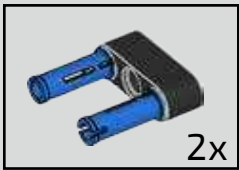

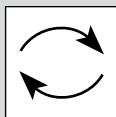

497

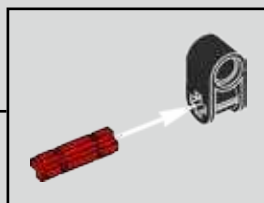
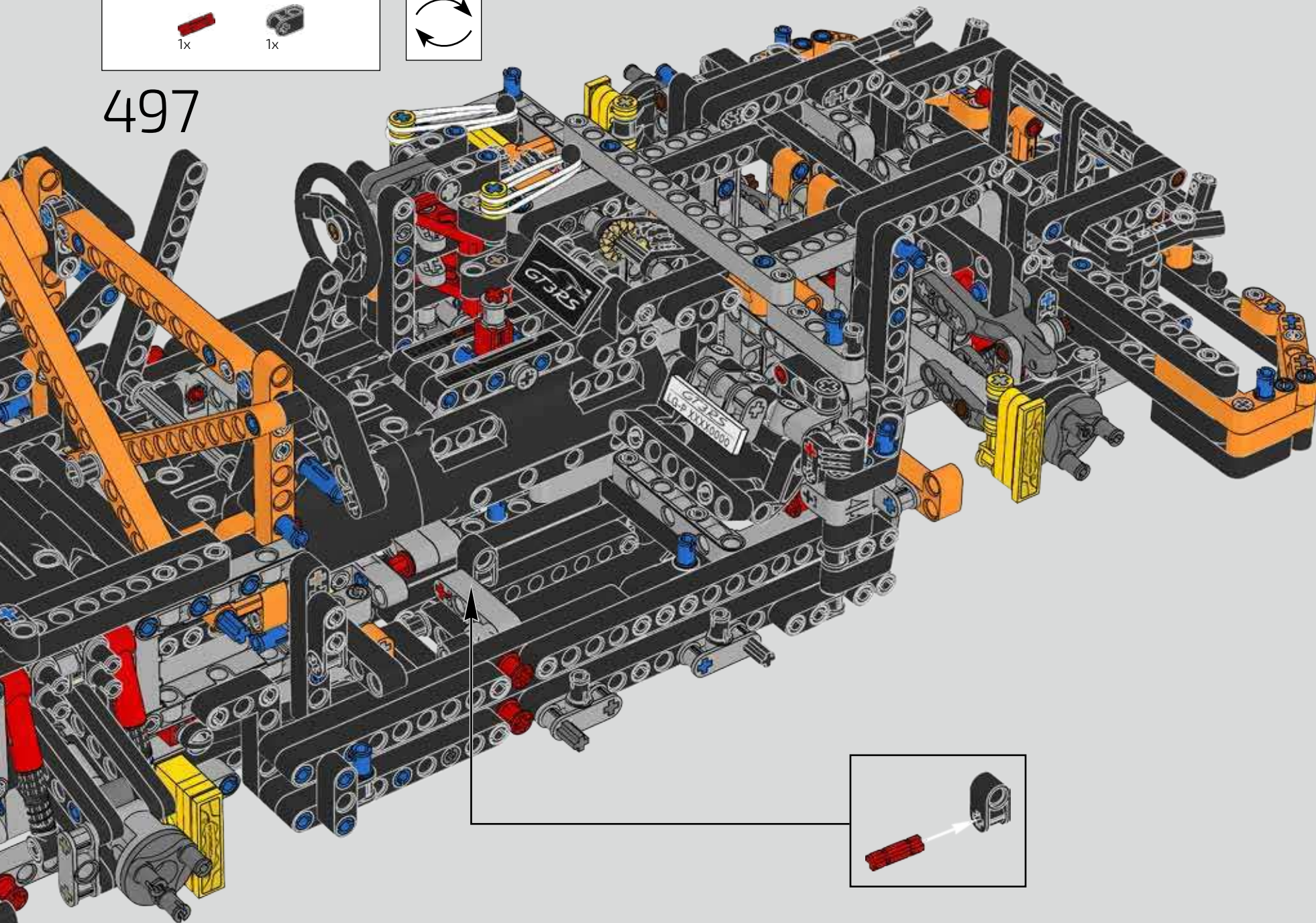

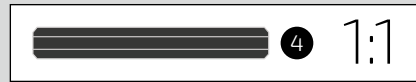
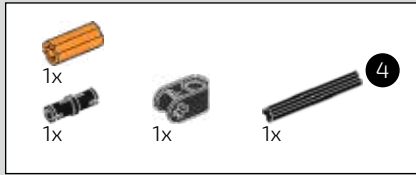

498

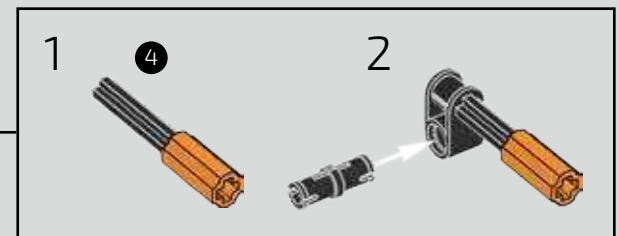
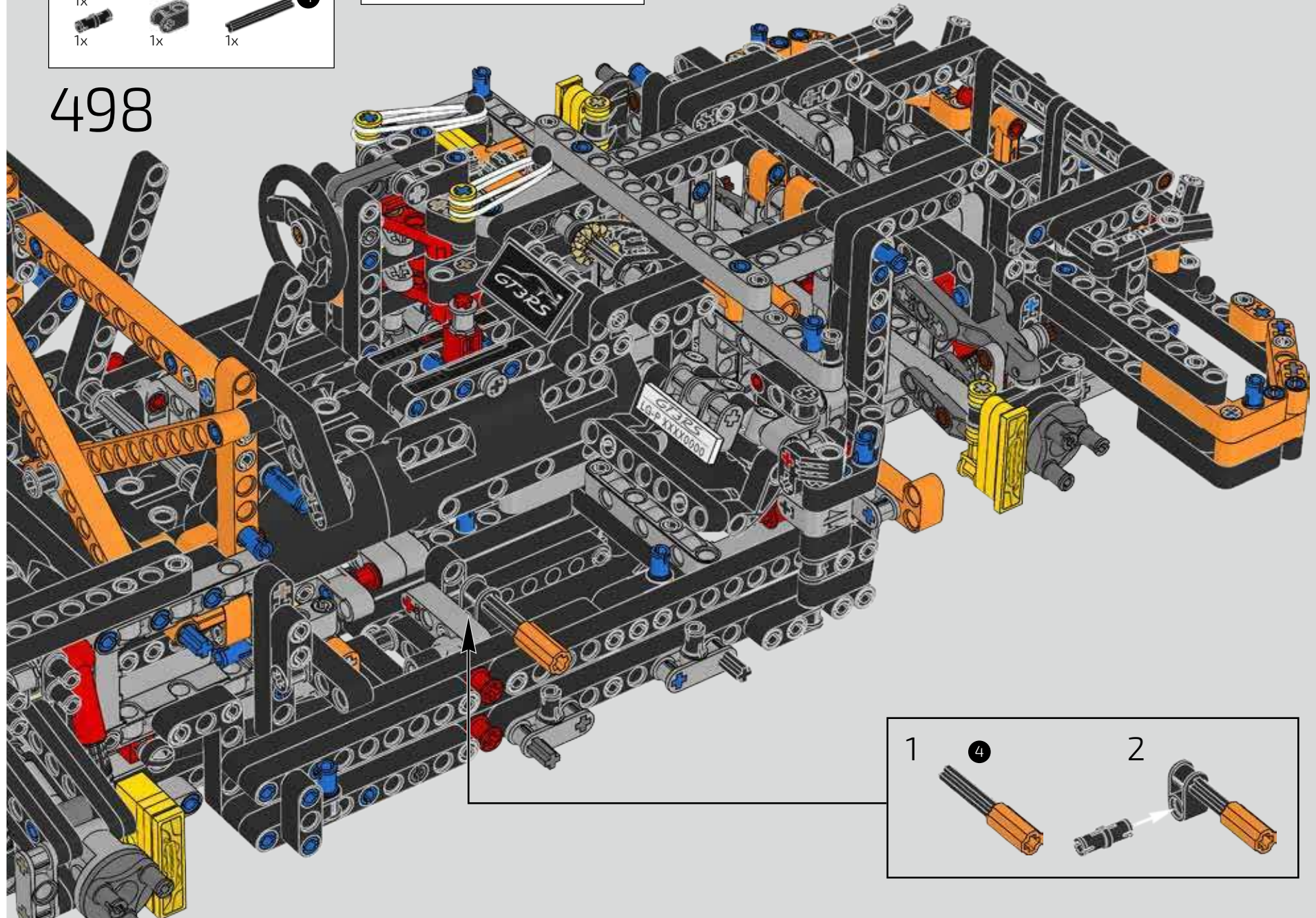

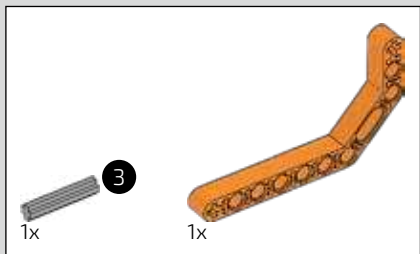

499

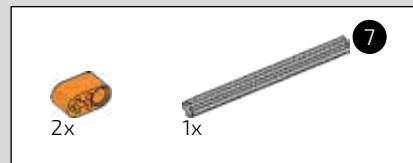
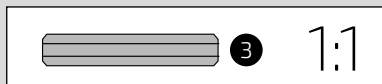

500

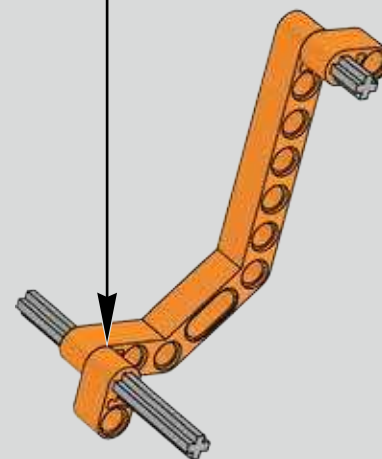
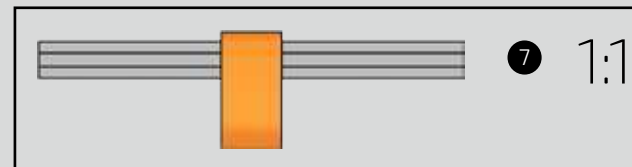

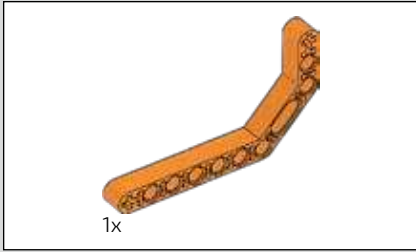

501

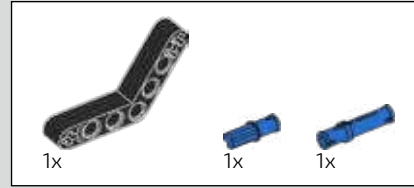
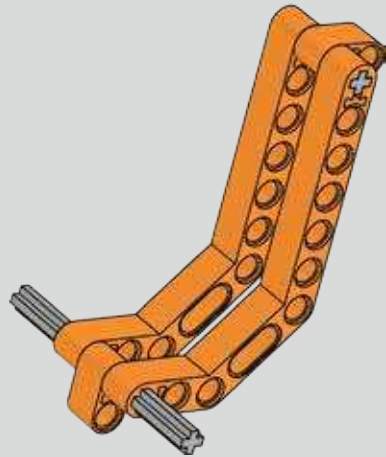

502

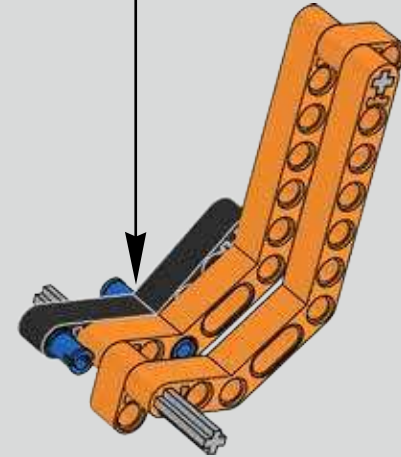
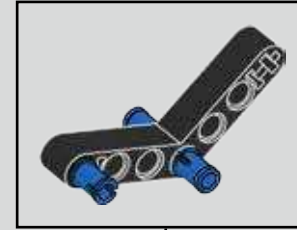

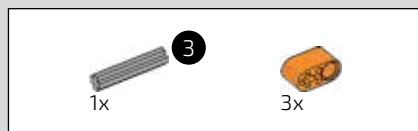

503

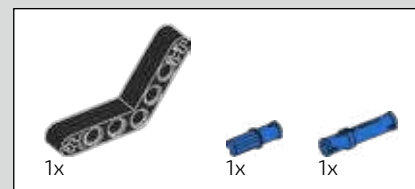
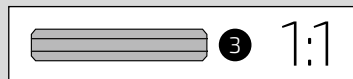
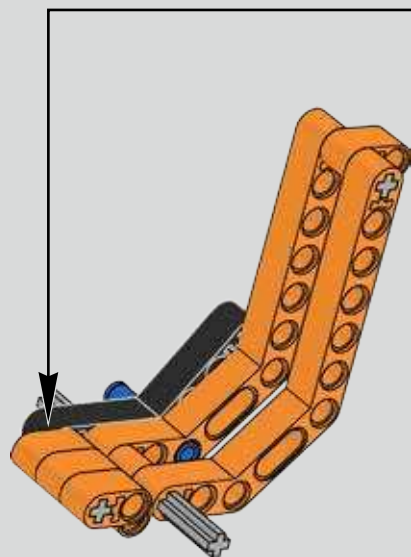

504

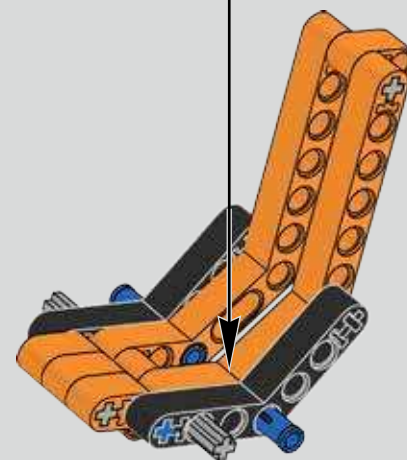
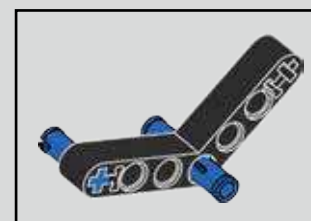

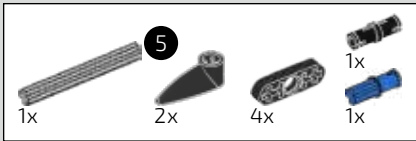

505

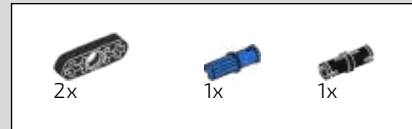
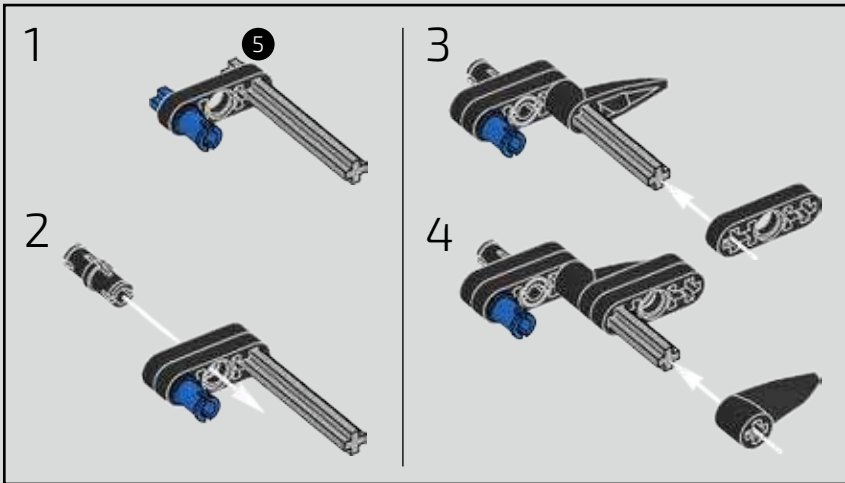

506

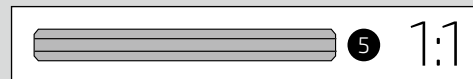
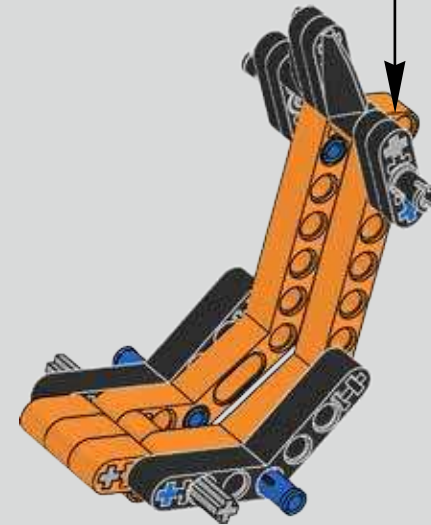
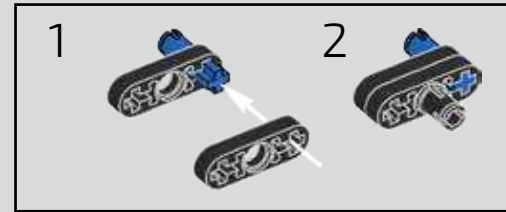

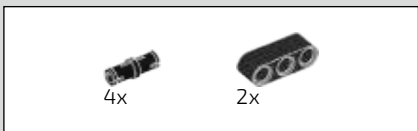

507

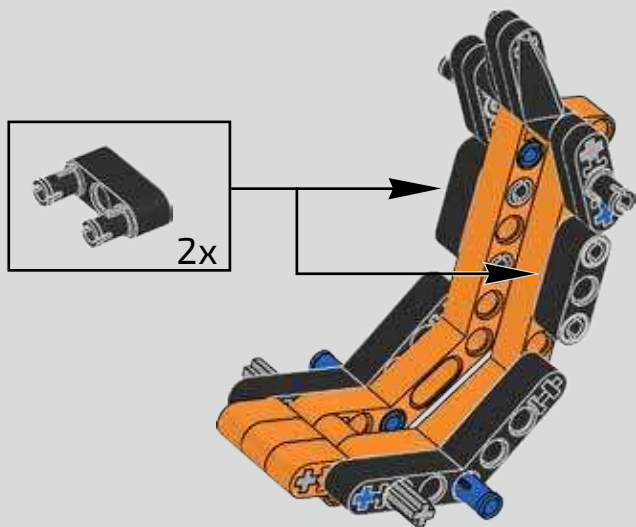

508



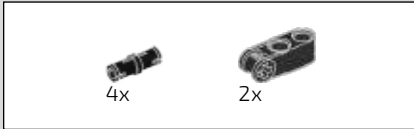

509

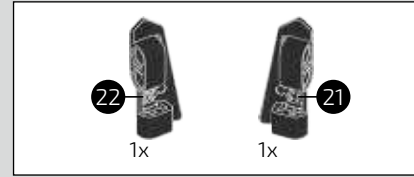
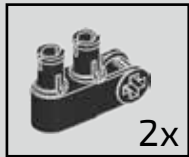

510



511

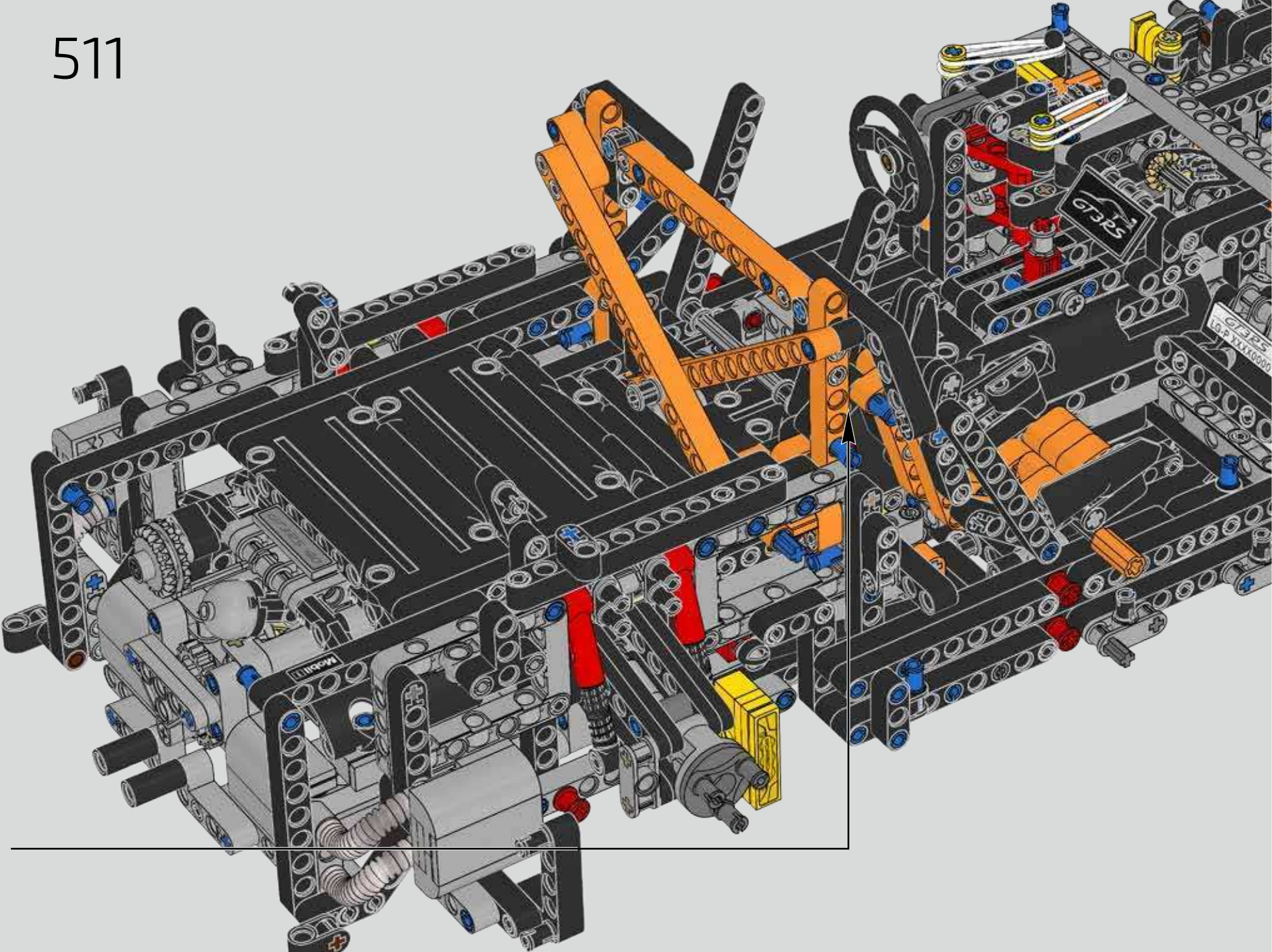

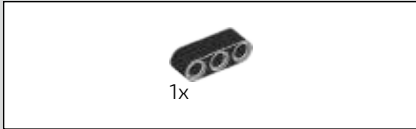

512

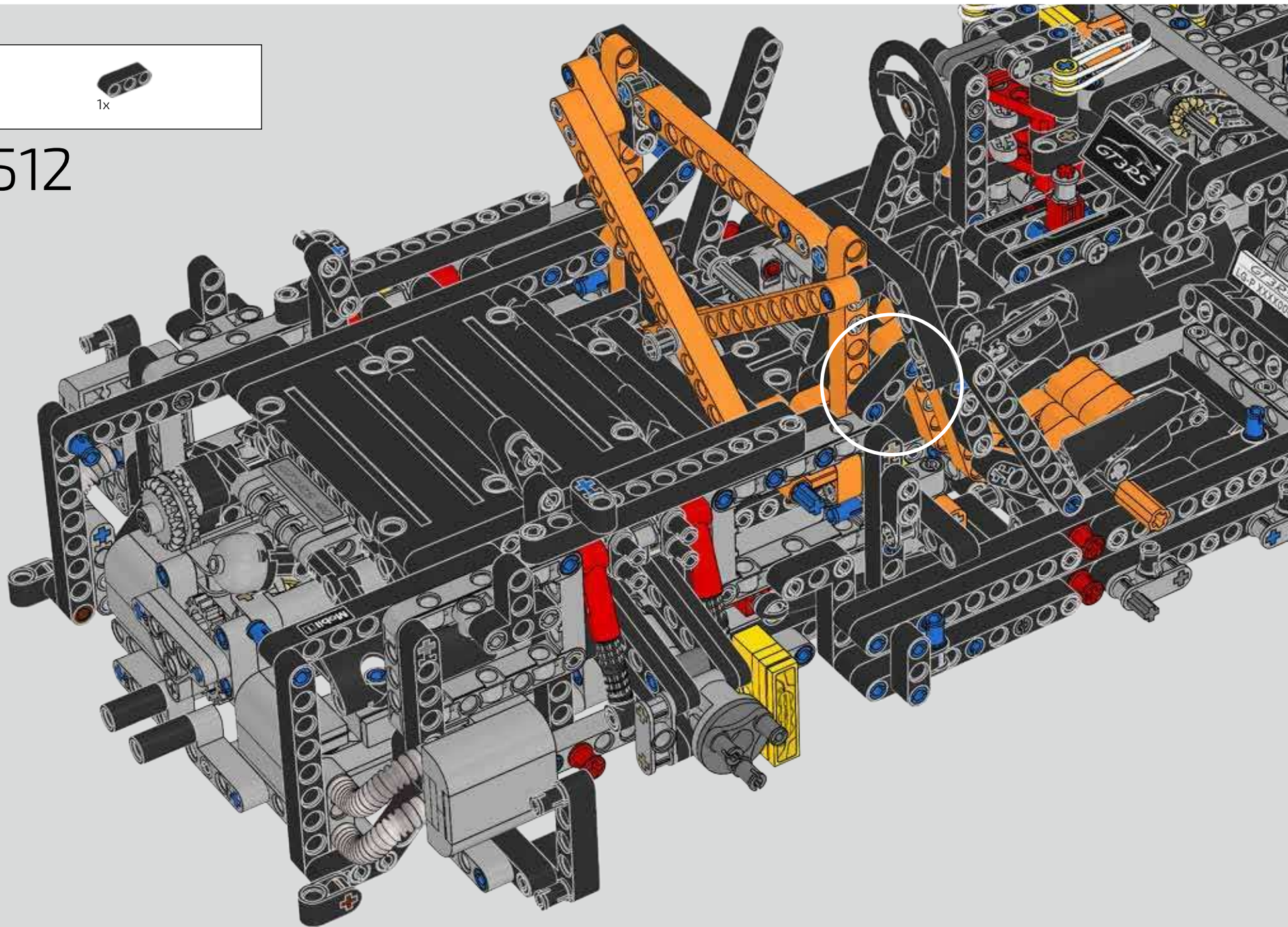

513

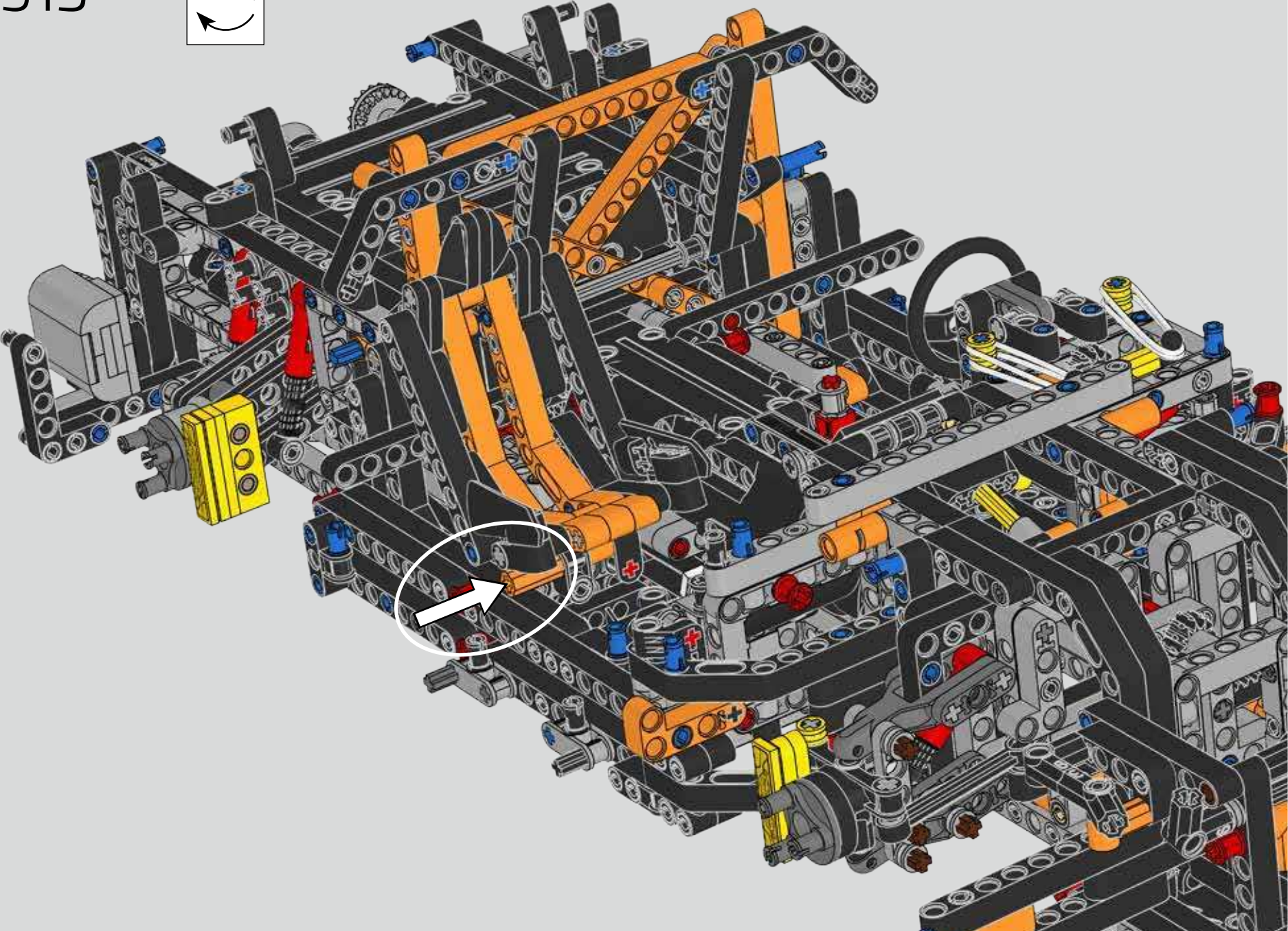
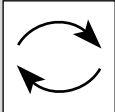



514

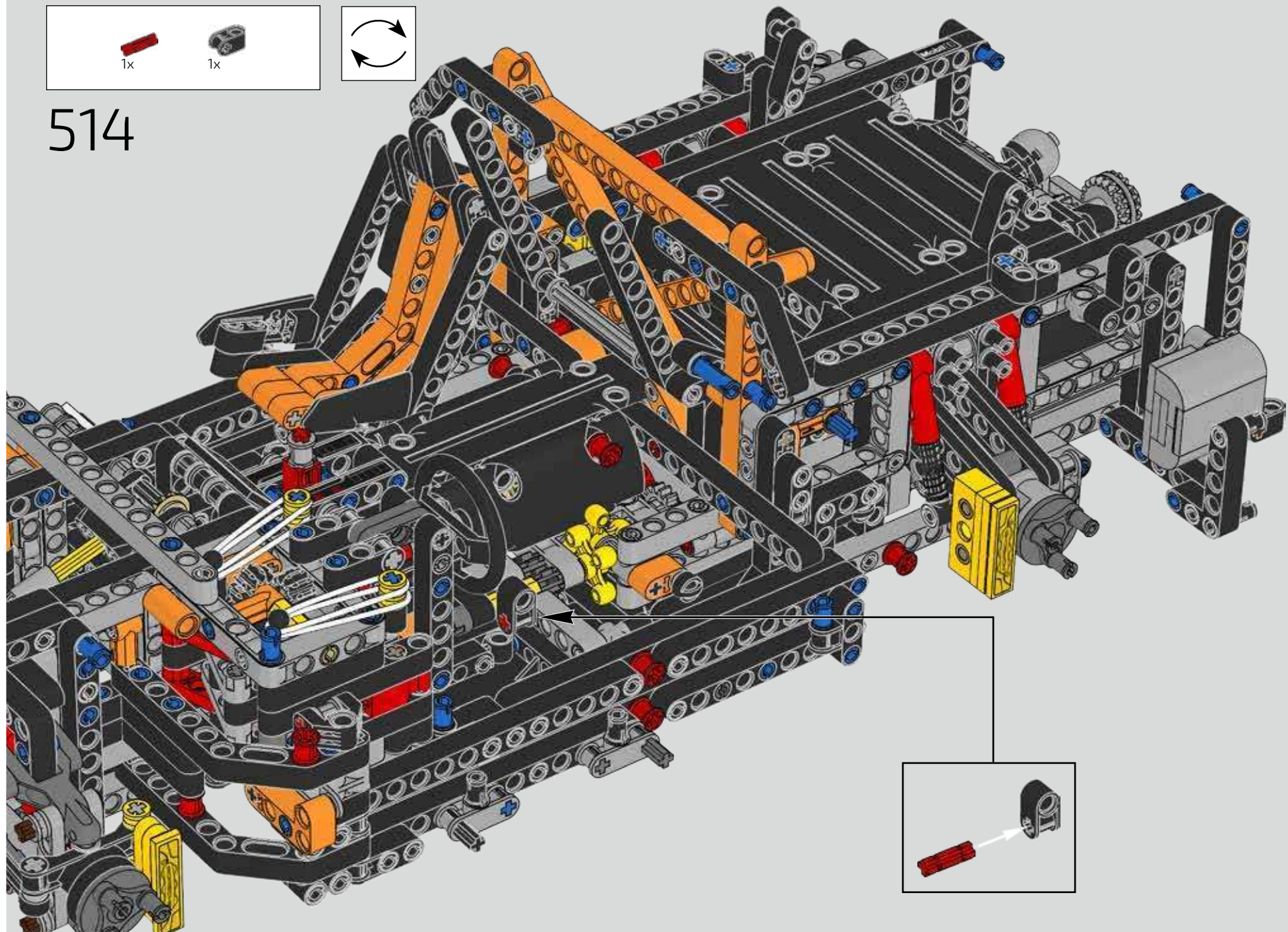

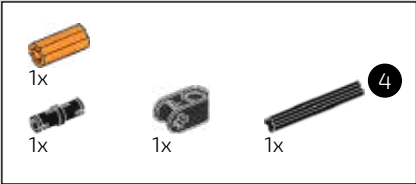

515

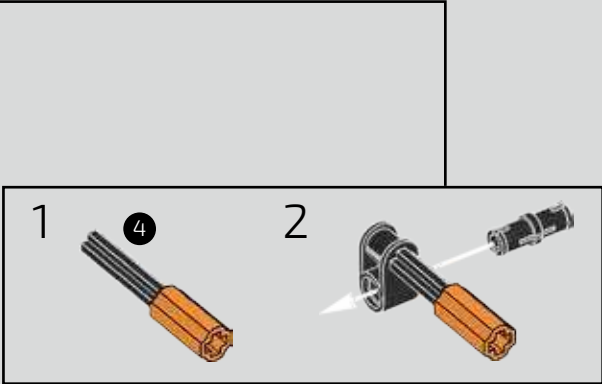
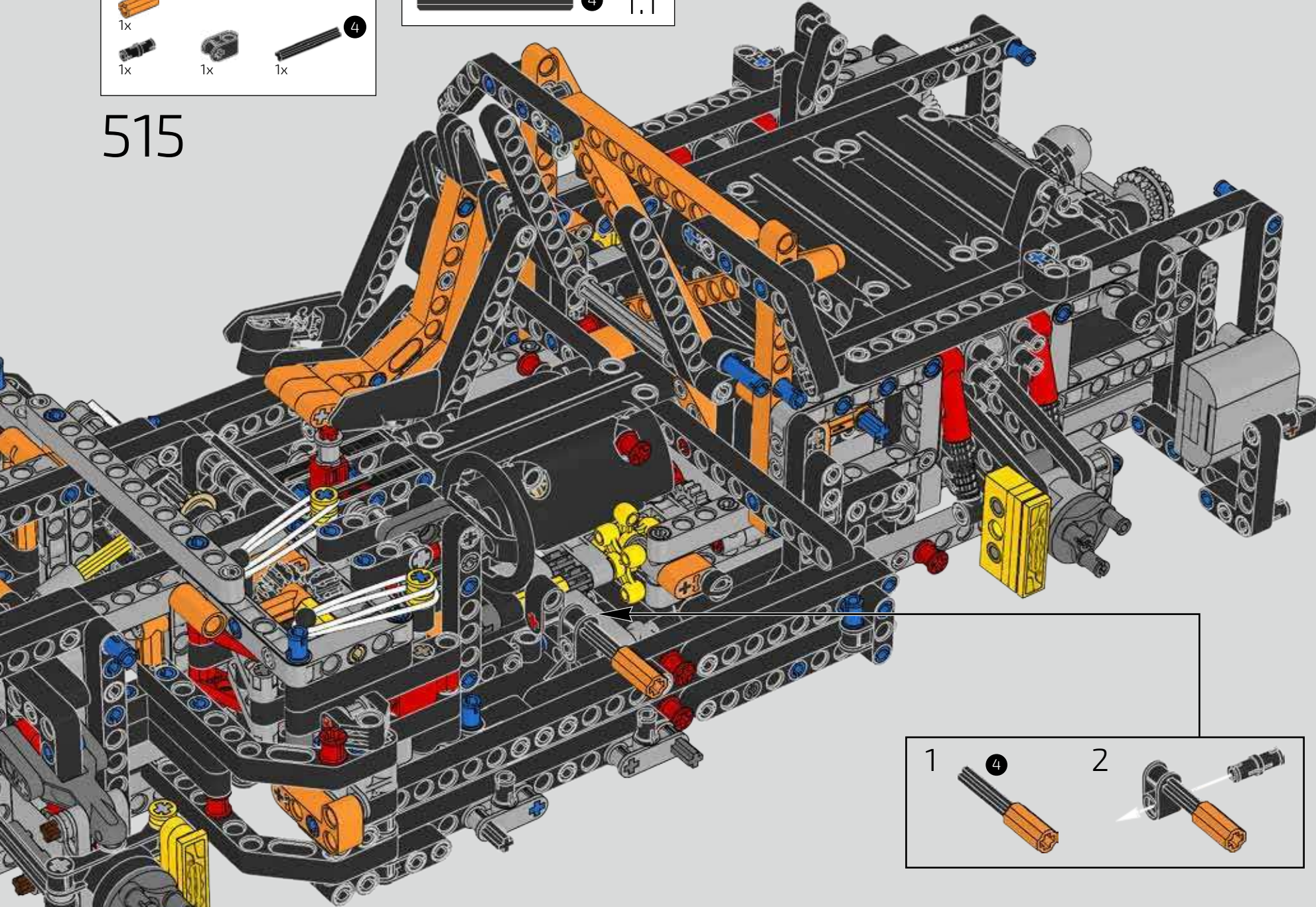

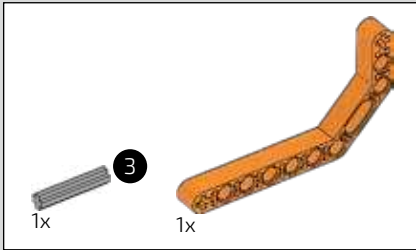

516

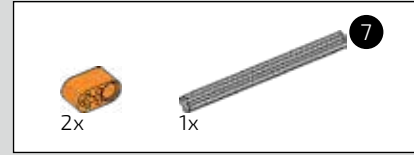
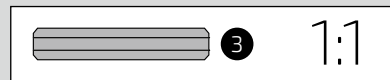

517

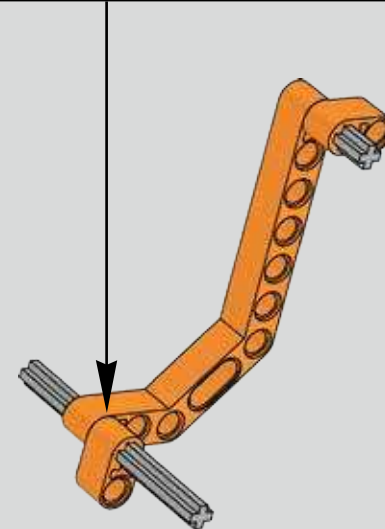
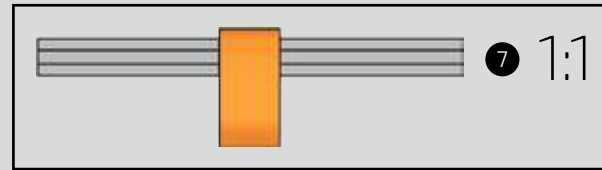

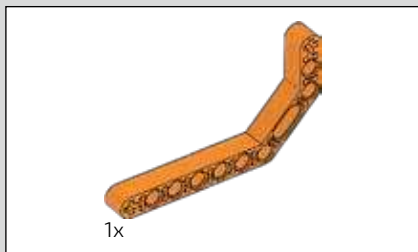

518

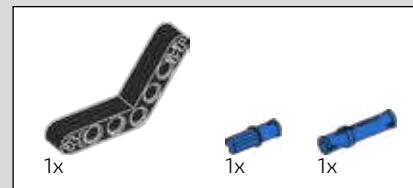
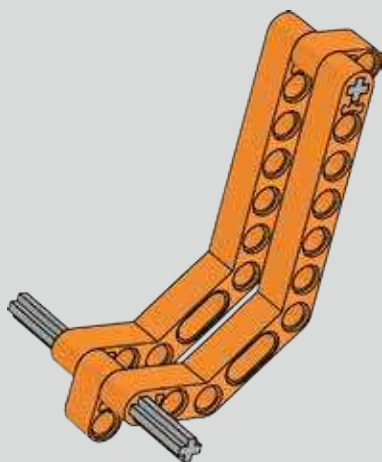

519

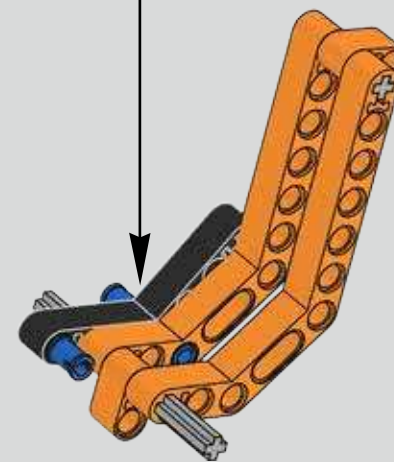

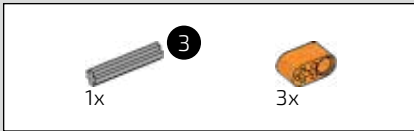

520

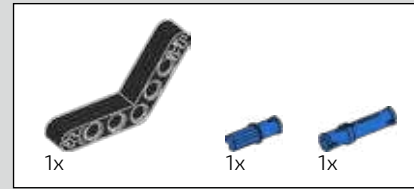
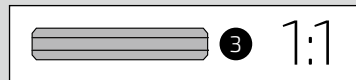
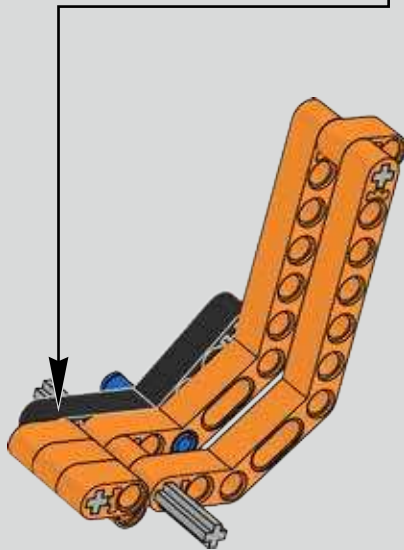

521

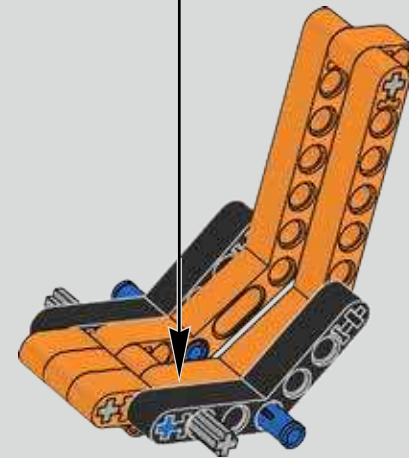
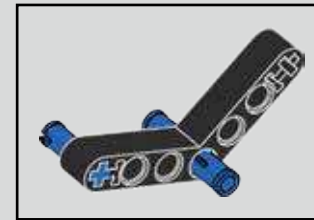

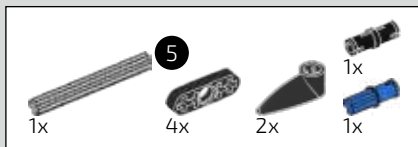

522

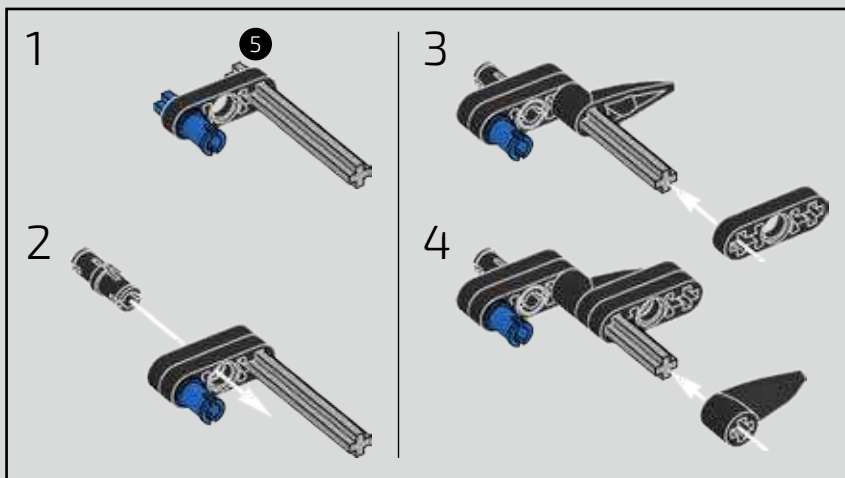

523

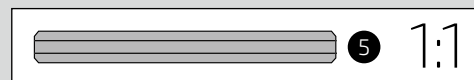
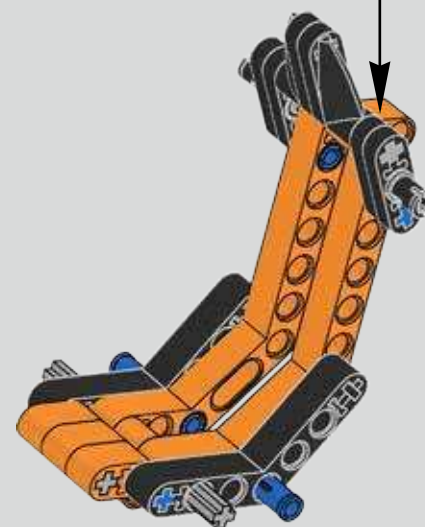
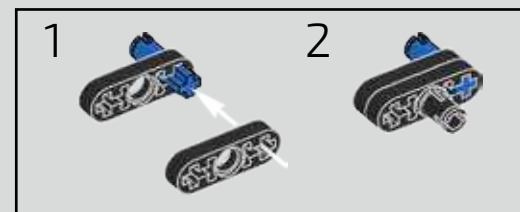

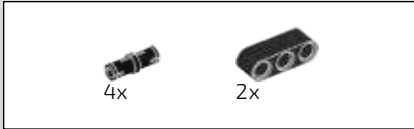

524

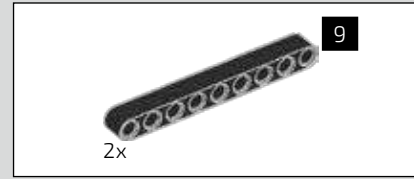
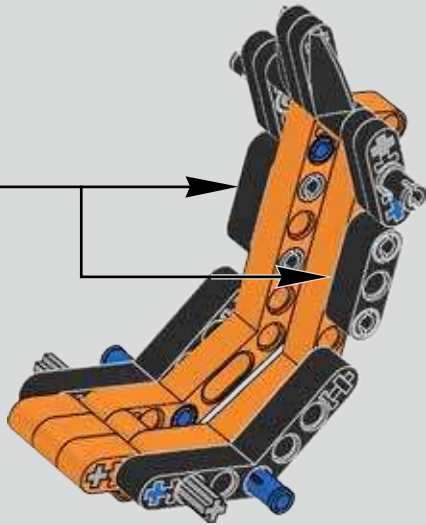
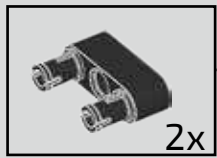

525





526

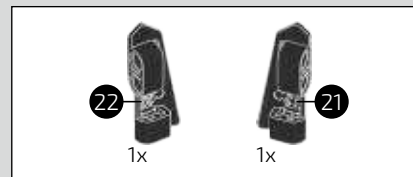
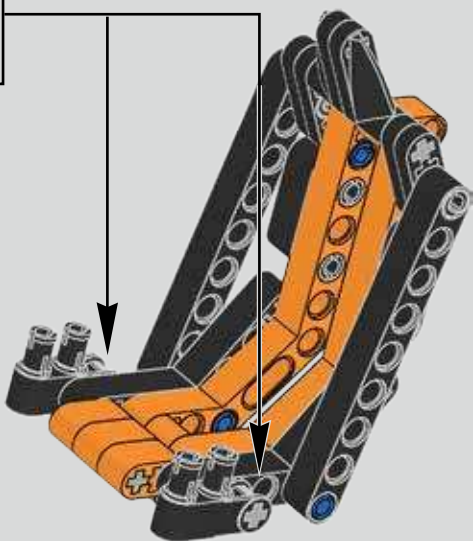
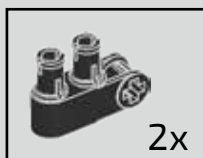

527



528

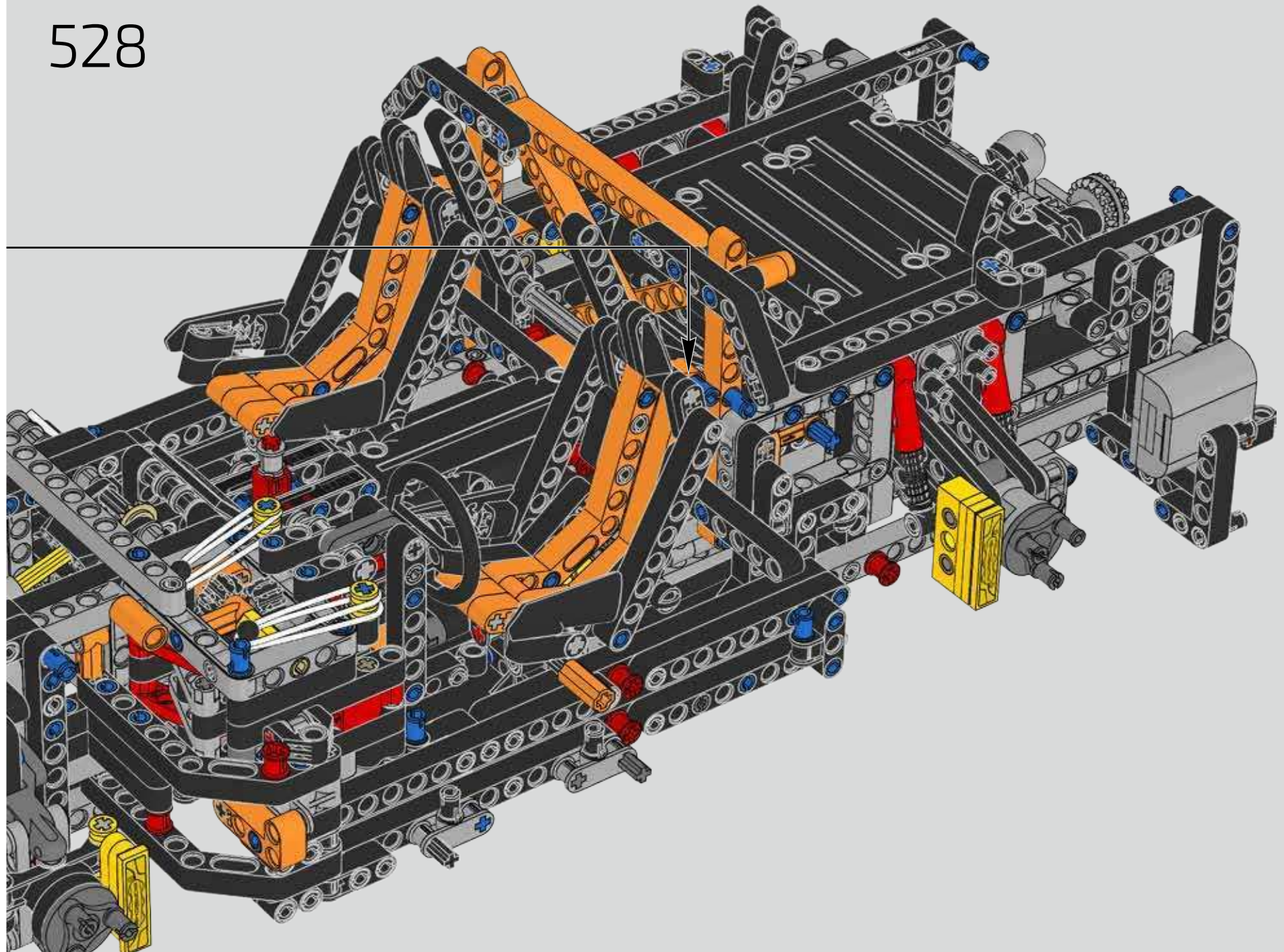

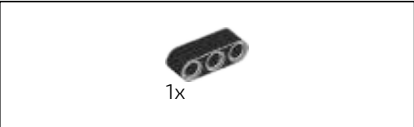

529

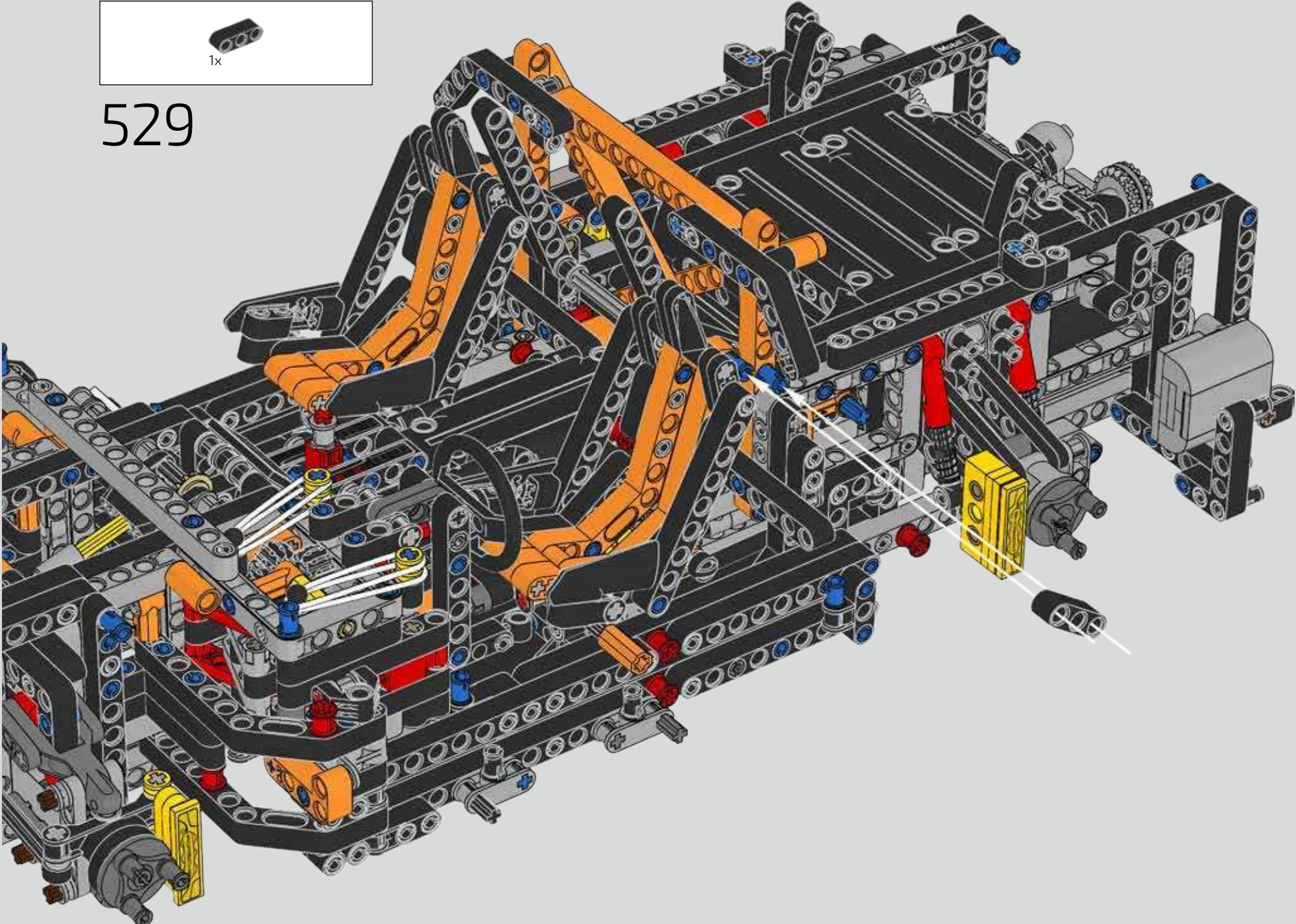

530

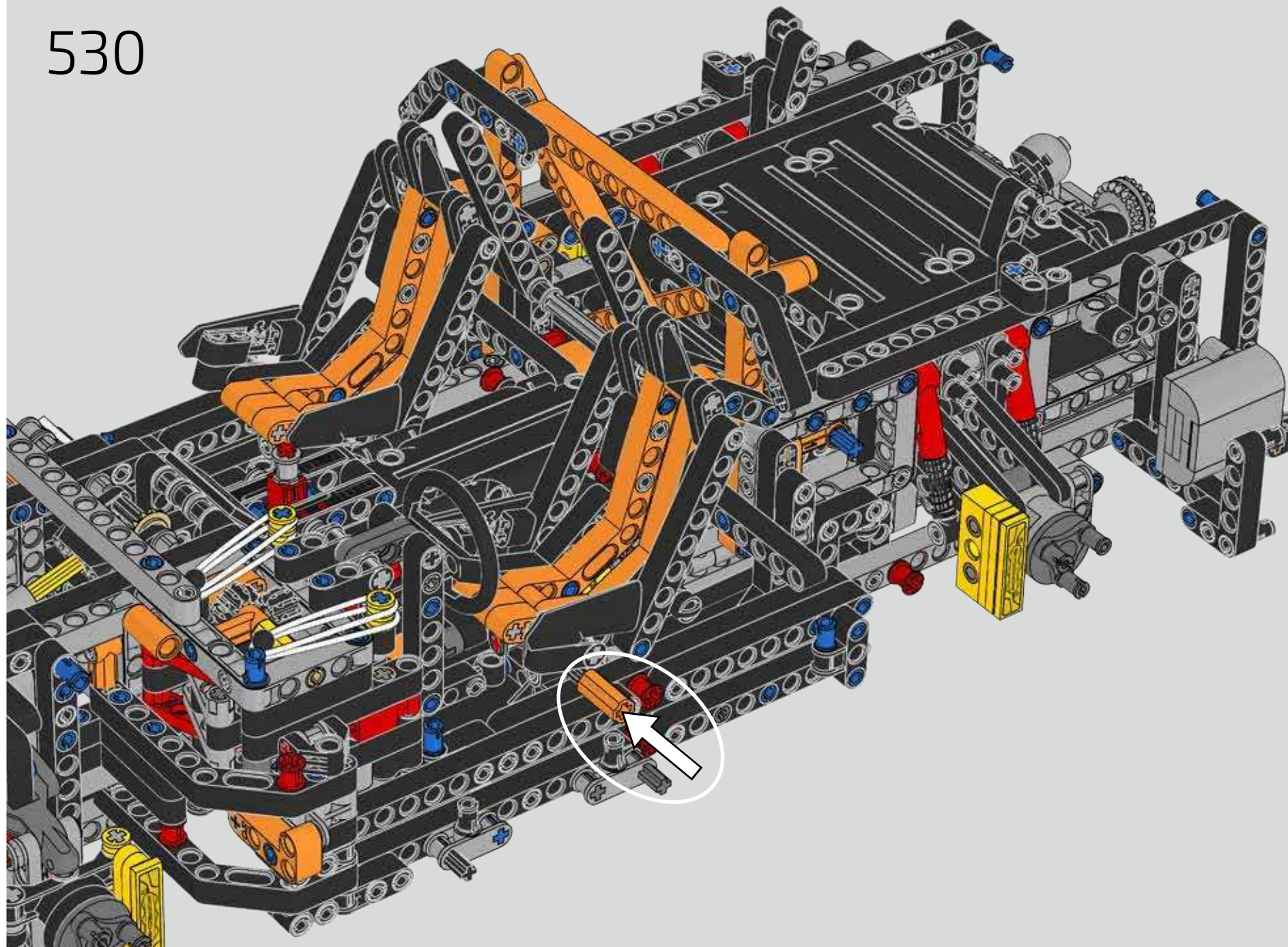

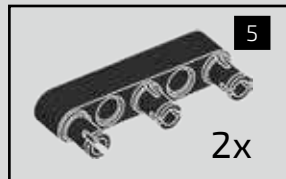
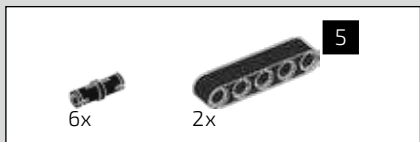

531

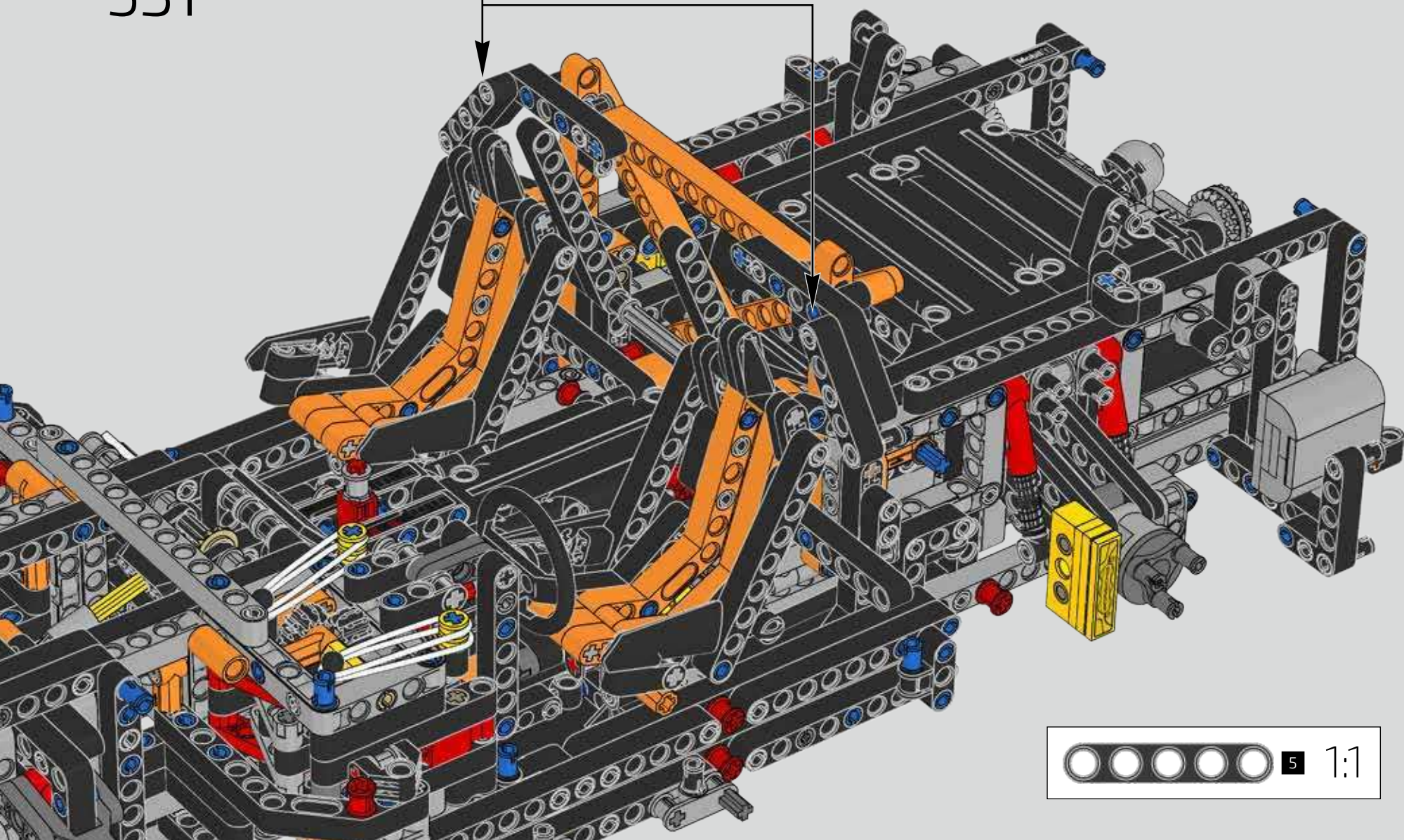



3

In box 3 you start to assemble the body of your 911 GT3 RS. Starting with the rear of the car and then onto the build of the iconic hood, now with distinctive shaping. Then it's the roof, again with distinctive shaping indicating the lightweight magnesium design only found on the newest 911 GT3 RS.

Mit Box 3 baust du die Karosserie deines 911 GT3 RS. Du beginnst mit dem Heck des Autos und arbeitest dich bis zum Frontdeckel mit seiner eigenständigen Formgebung vor. Danach ist das Dach an der Reihe, das ebenfalls über eine spezielle Kontur verfügt und aus einer leichten Magnesiumlegierung besteht, die nur im neuesten 911 GT3 RS zum Einsatz kommt.



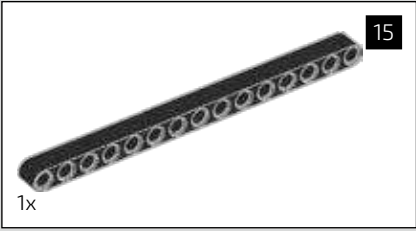

532

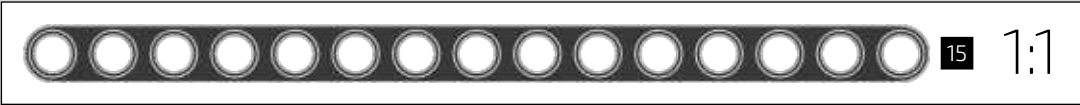
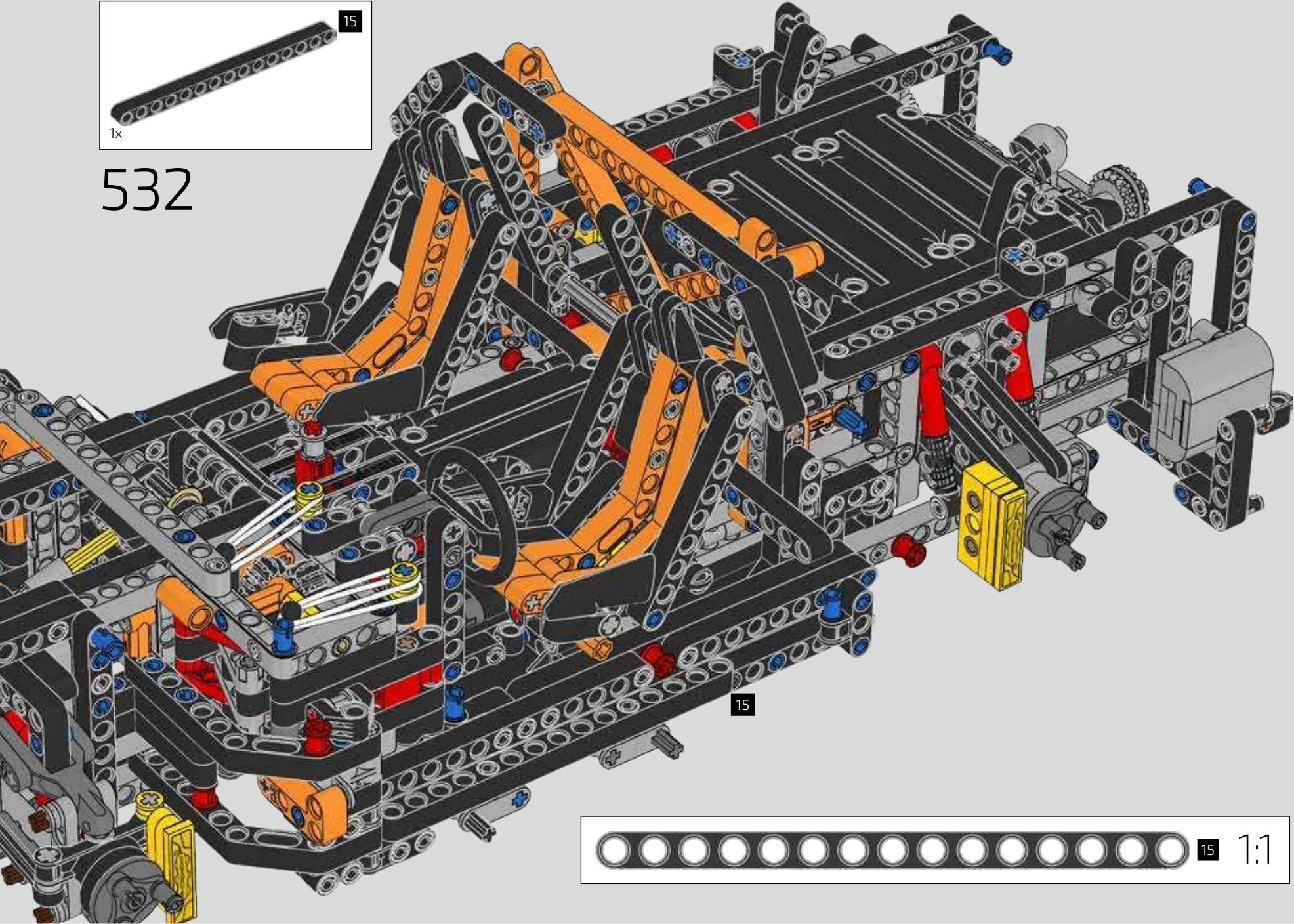

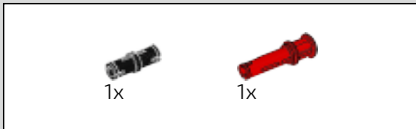

533

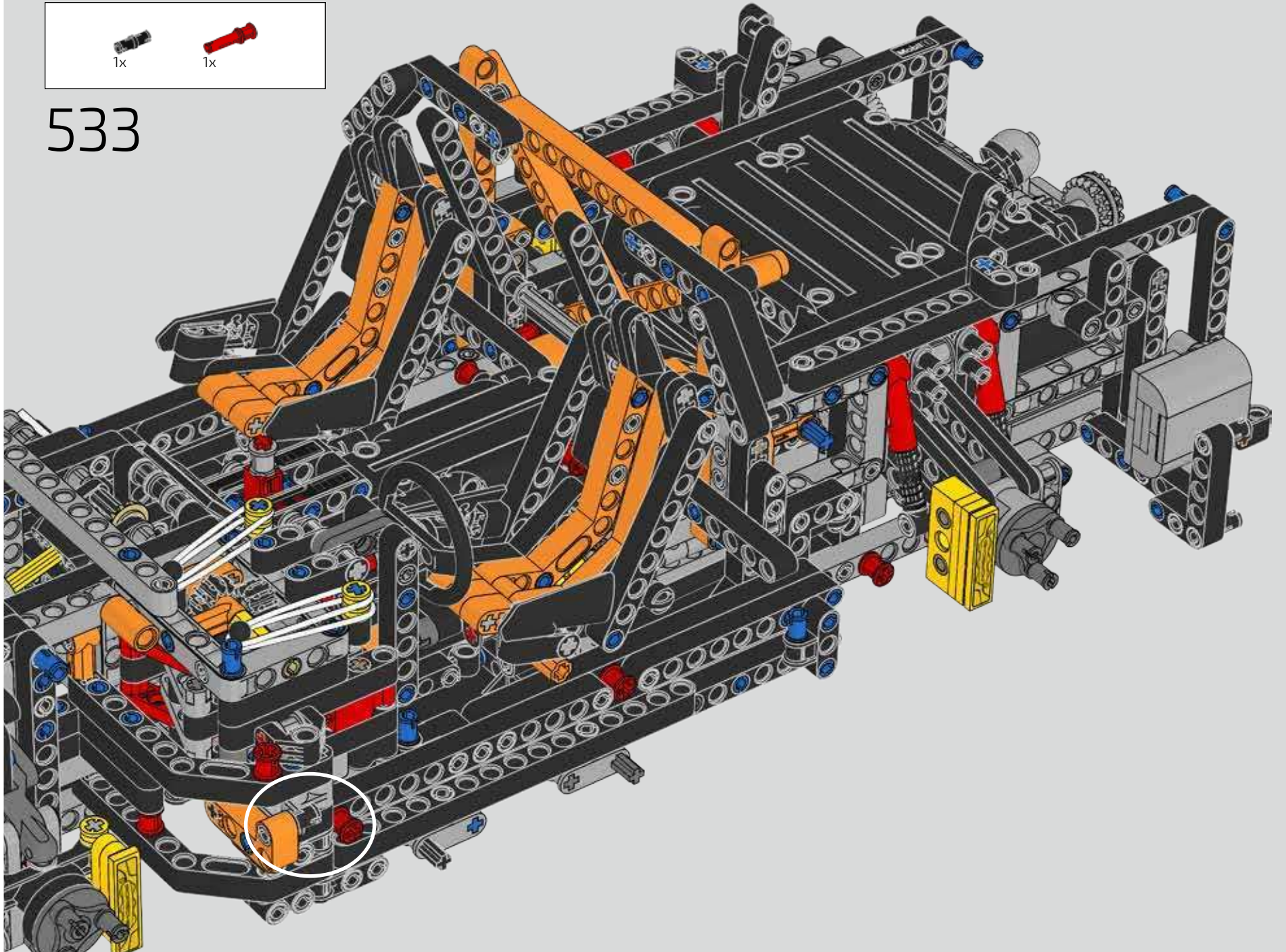

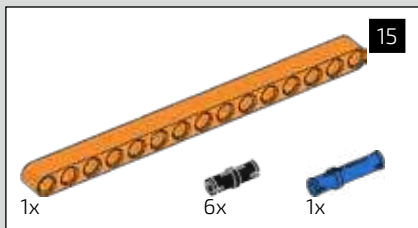
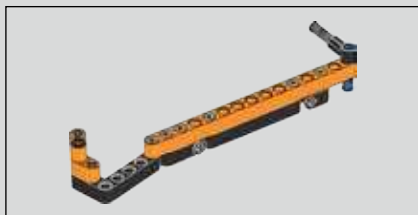

534

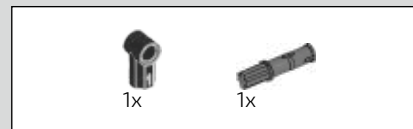
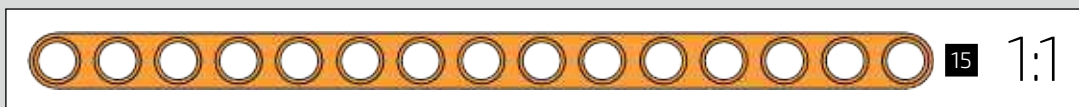
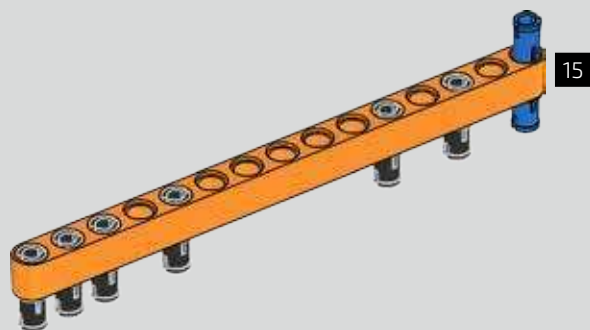

535

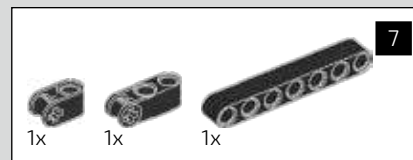
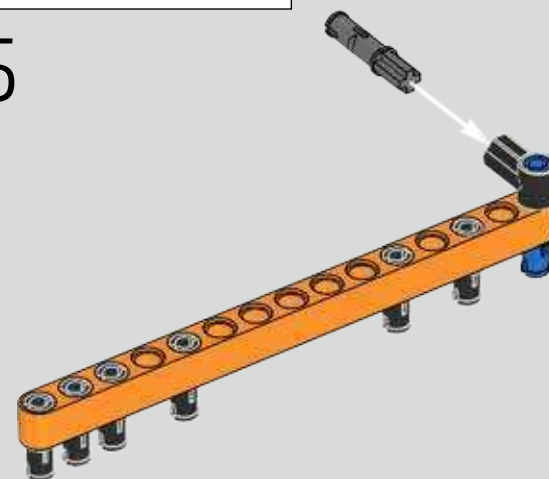

536

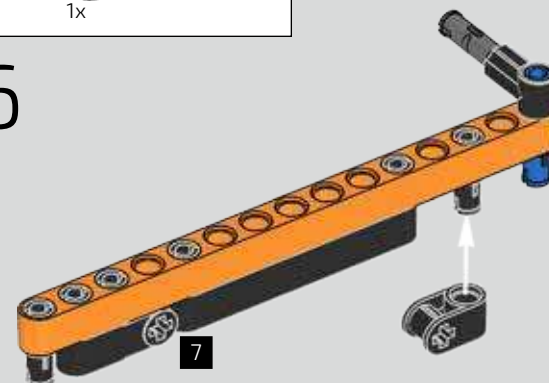

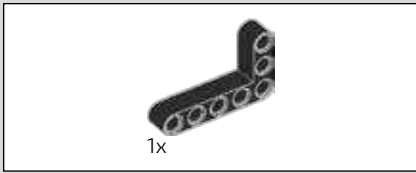

537

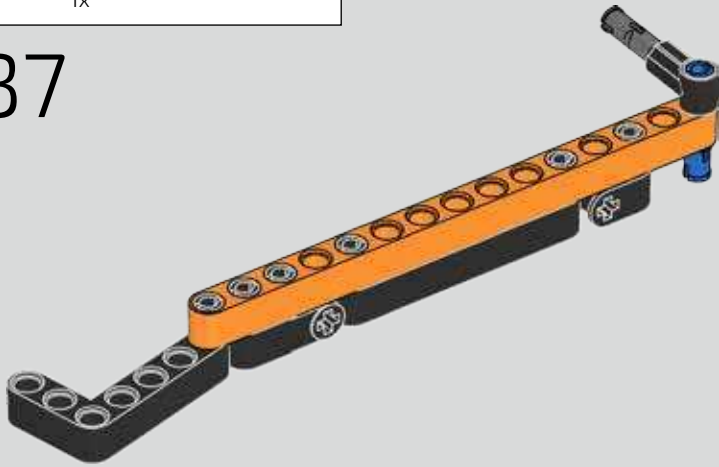

538

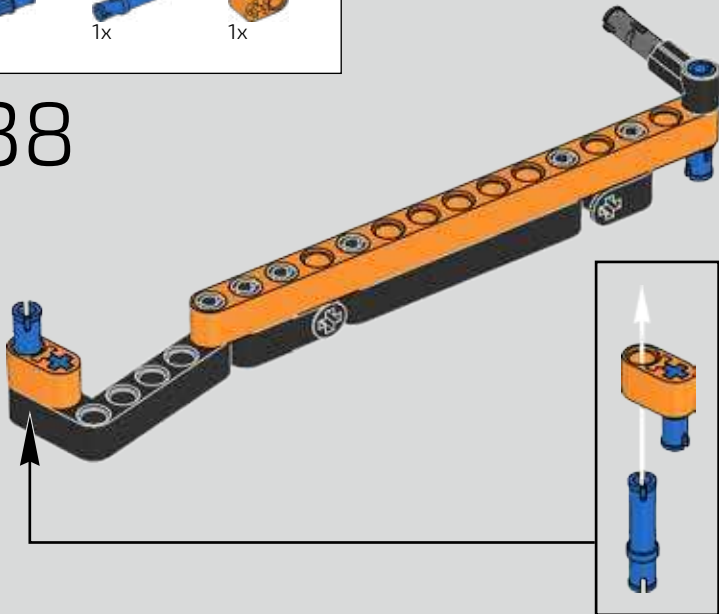

539

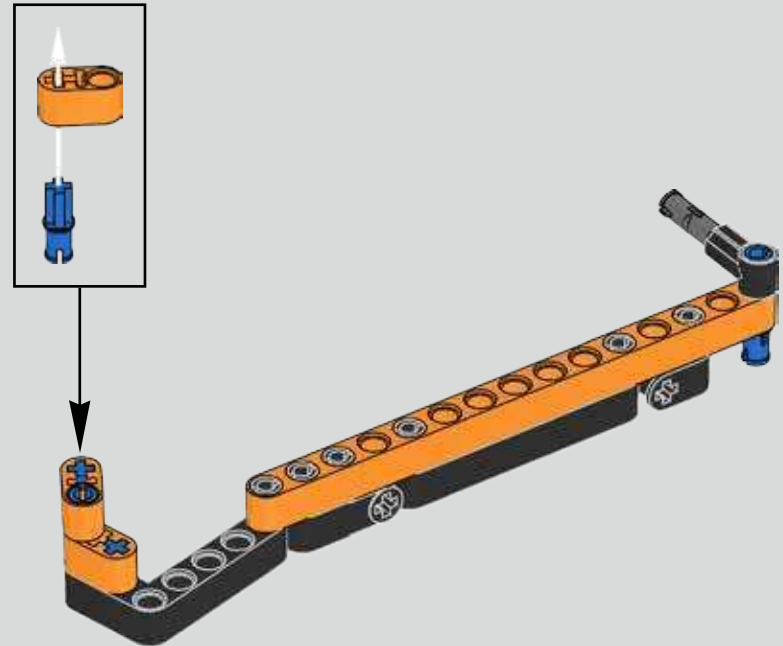

540

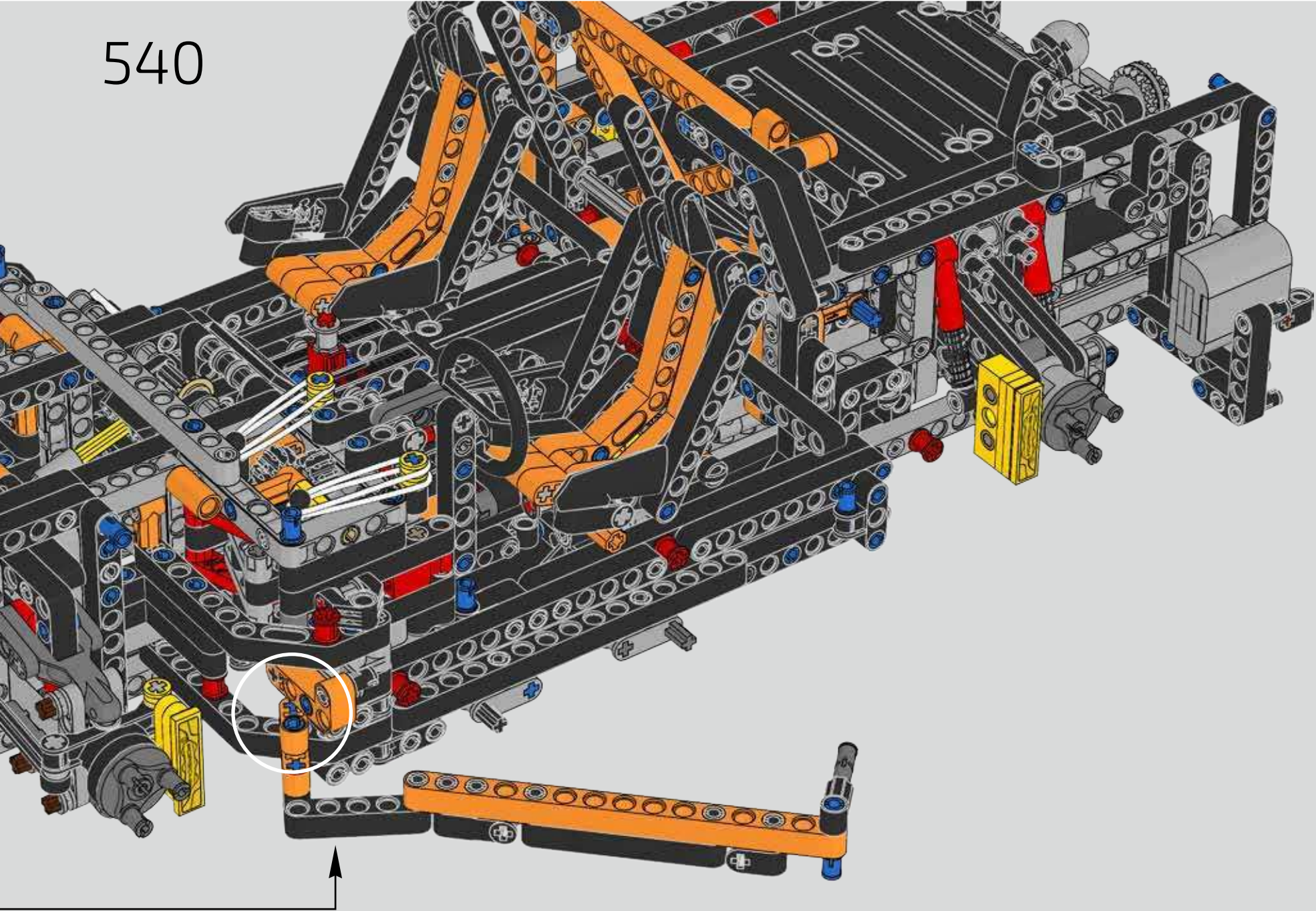

541

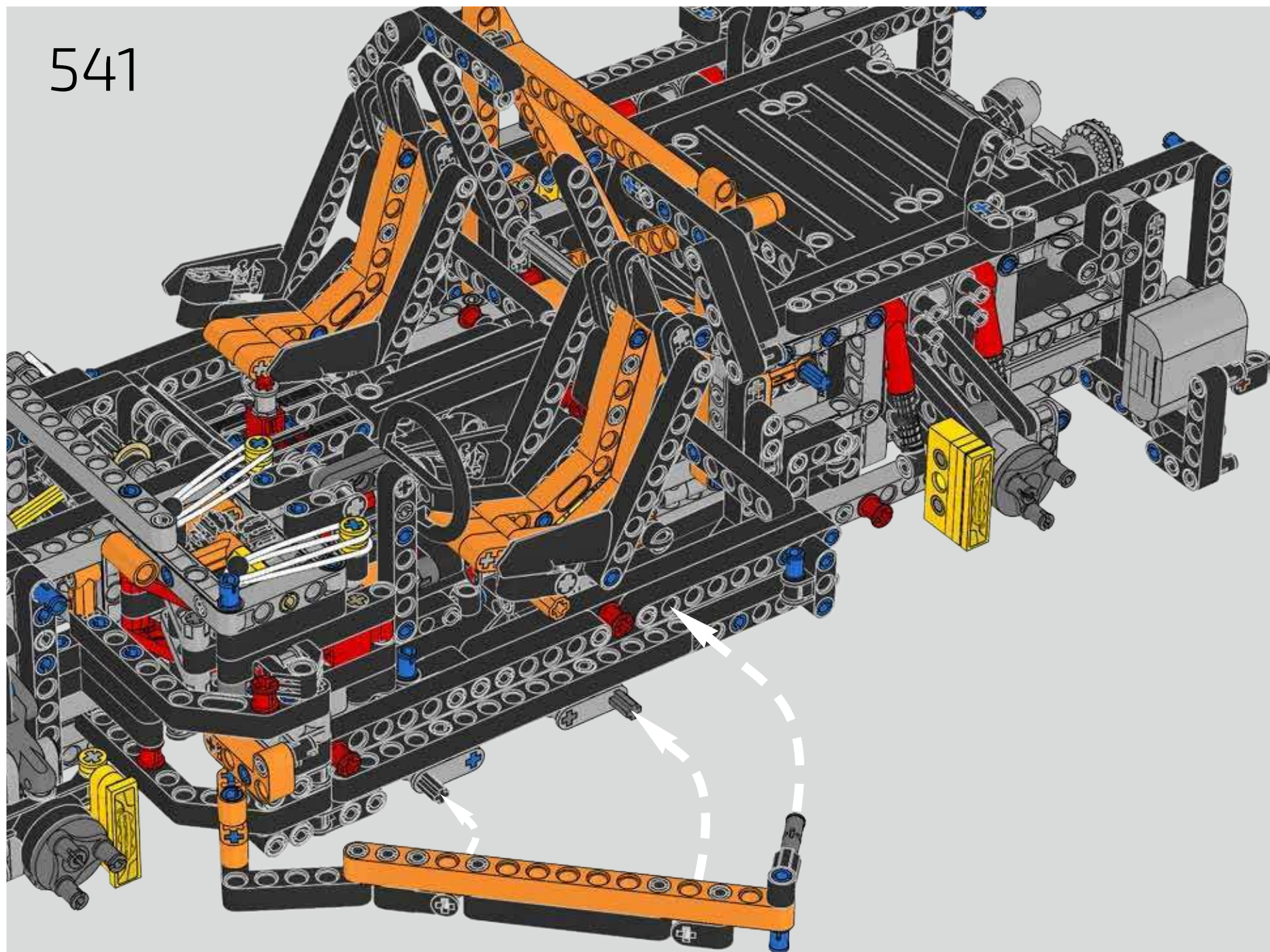

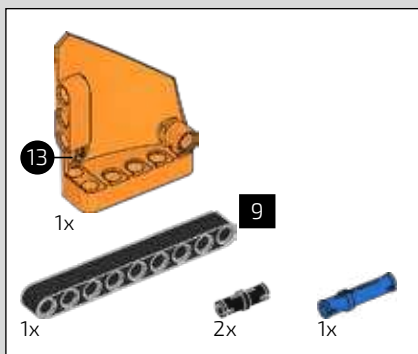

542

1

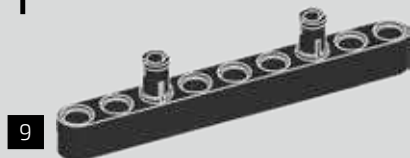

2

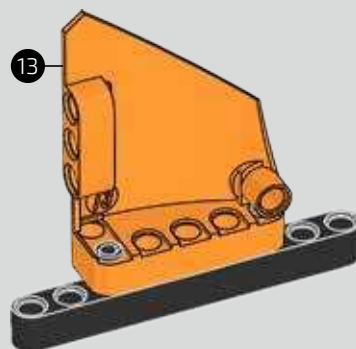

3

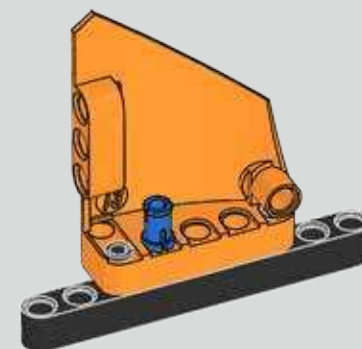

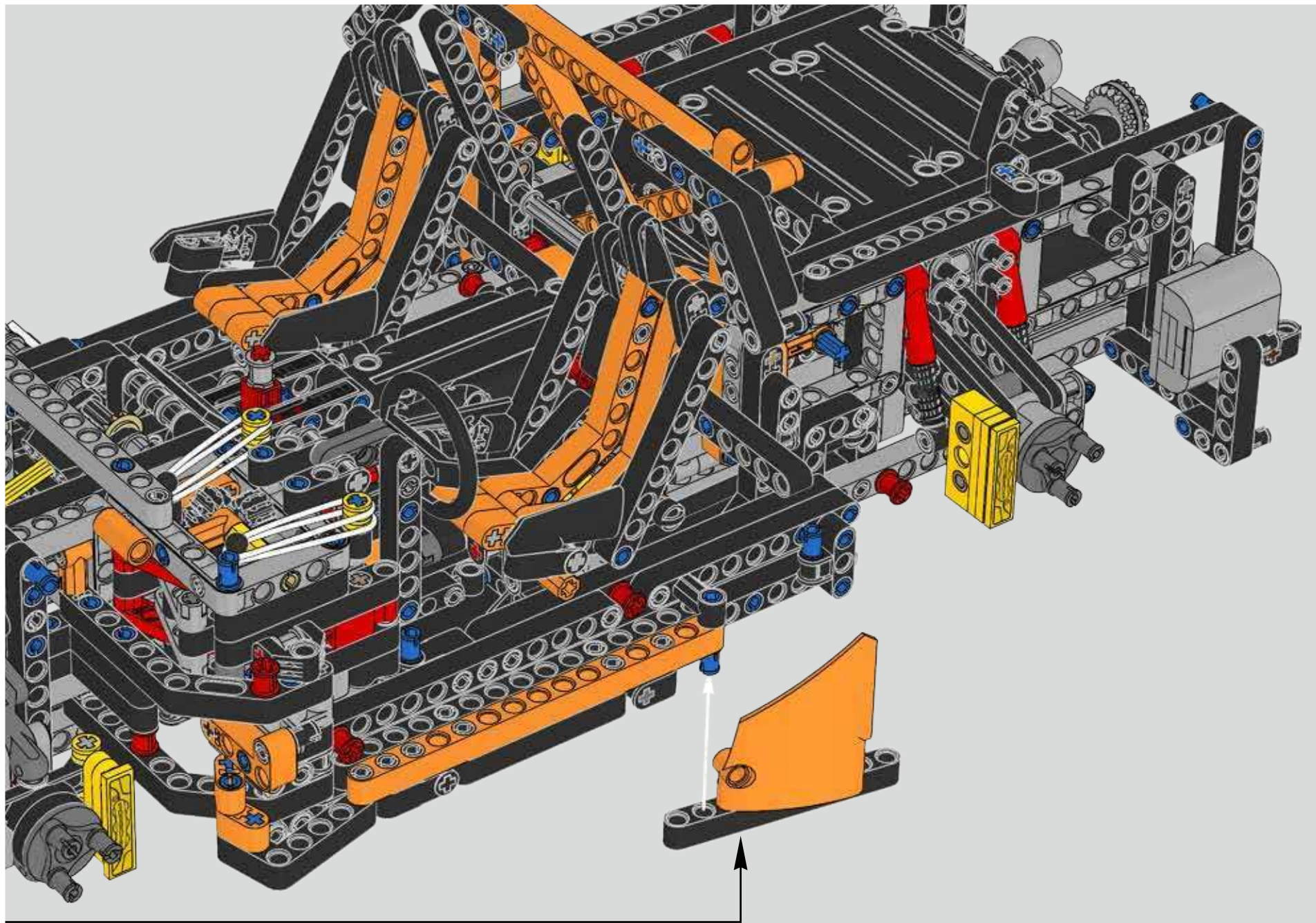

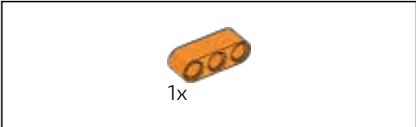

543

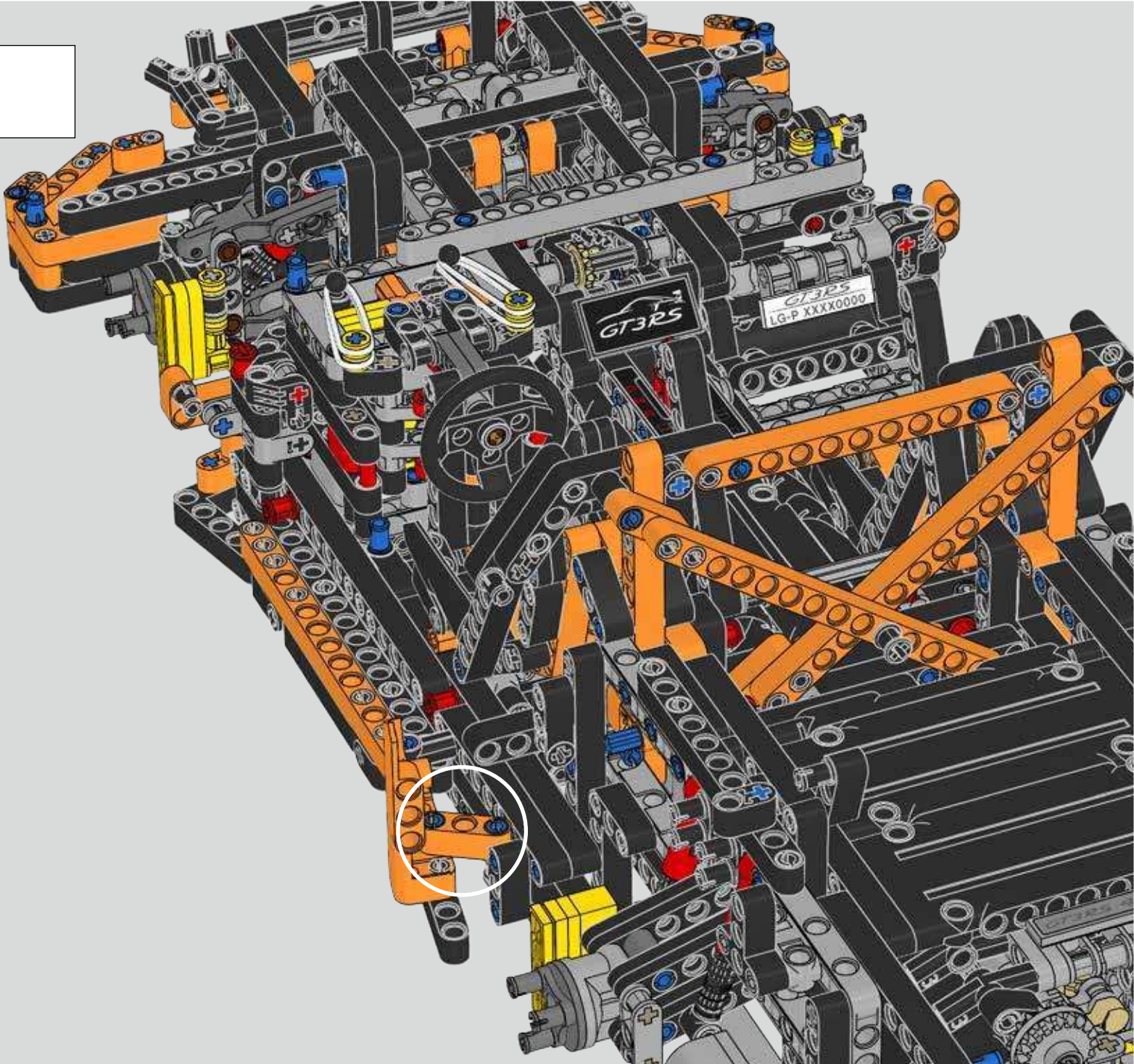
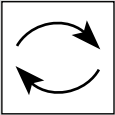



544

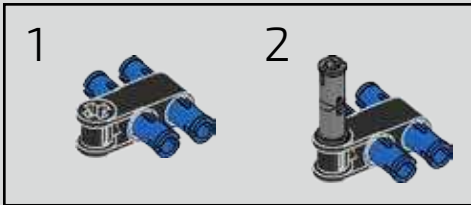
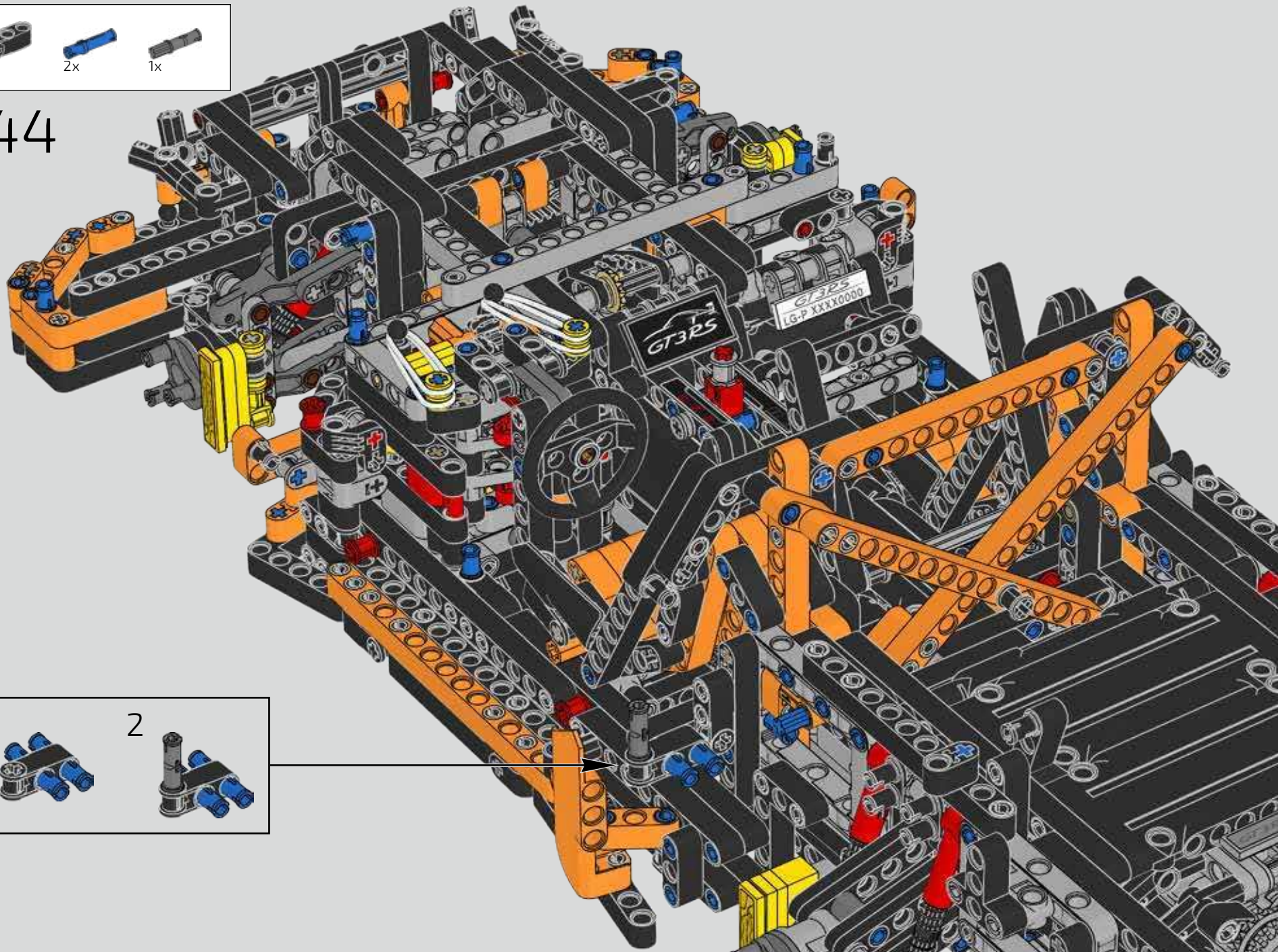

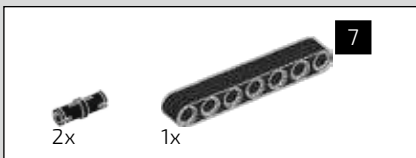

545

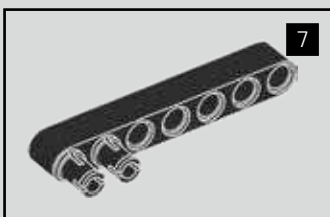
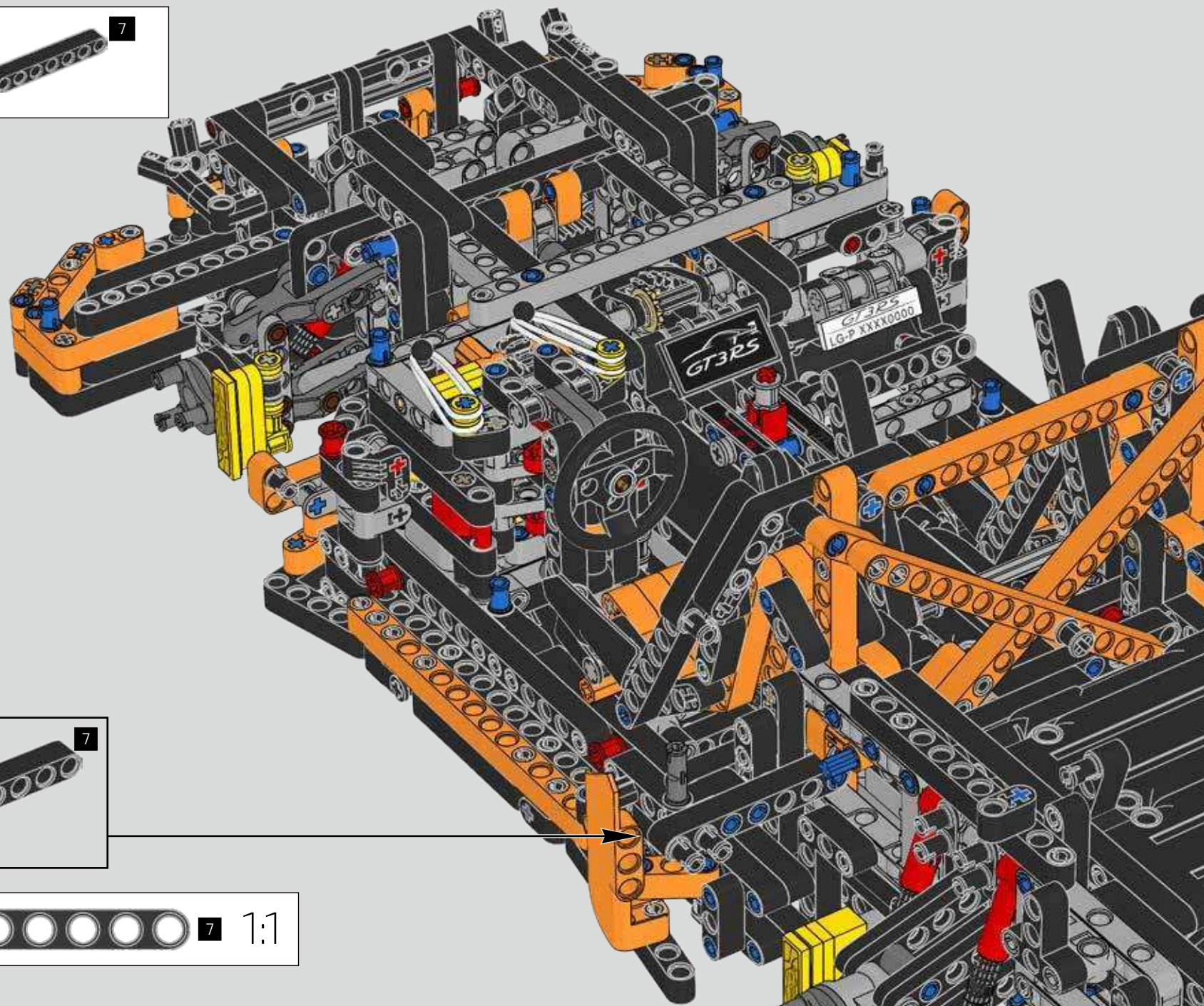

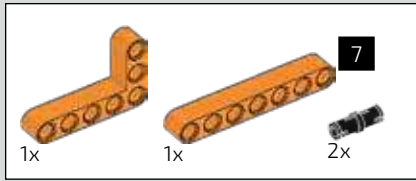

546

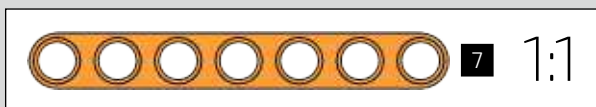
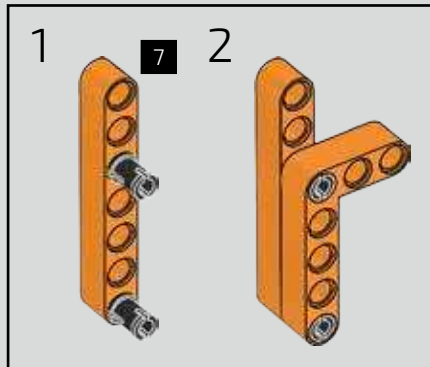
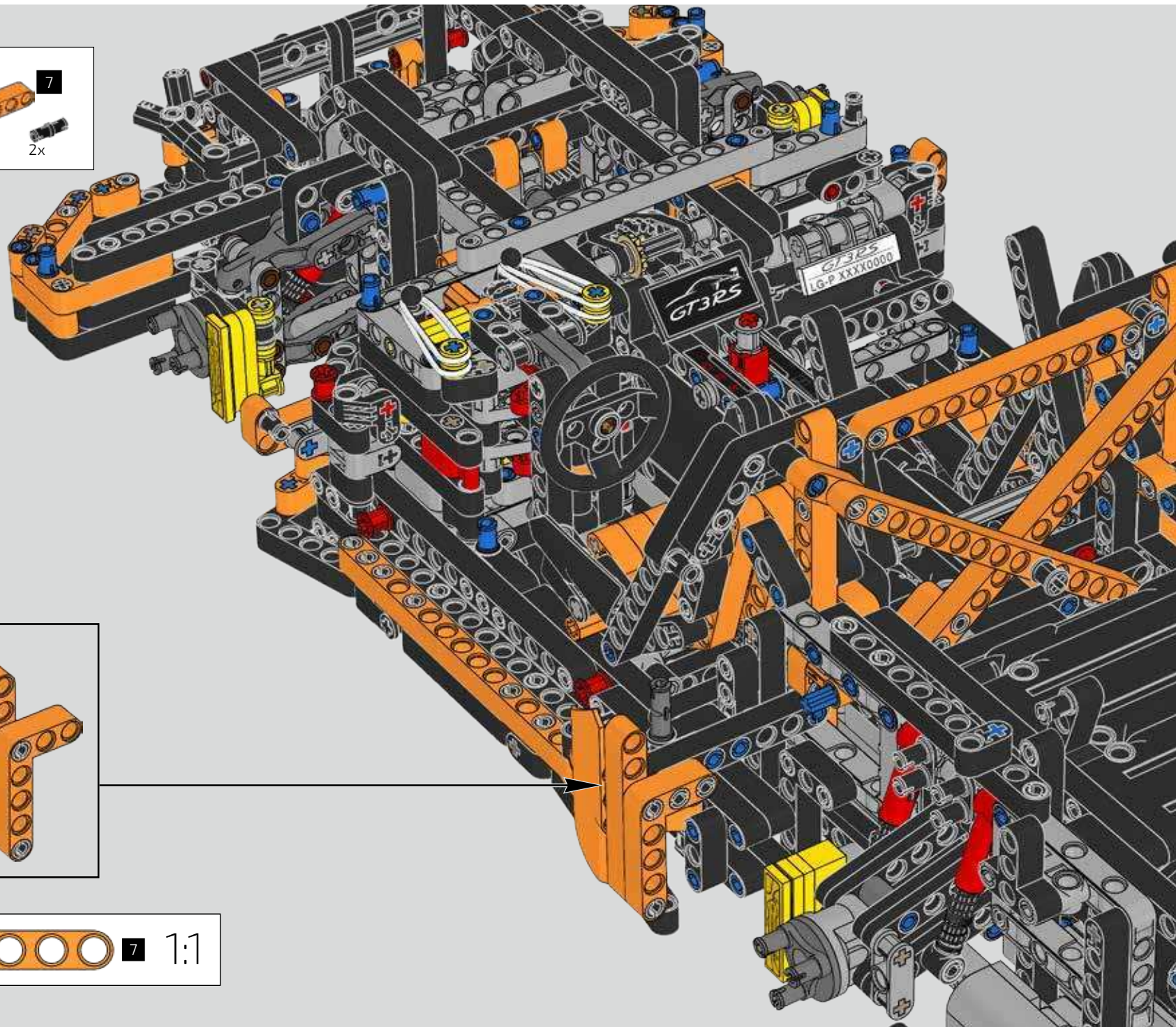

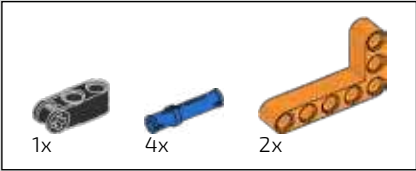

547

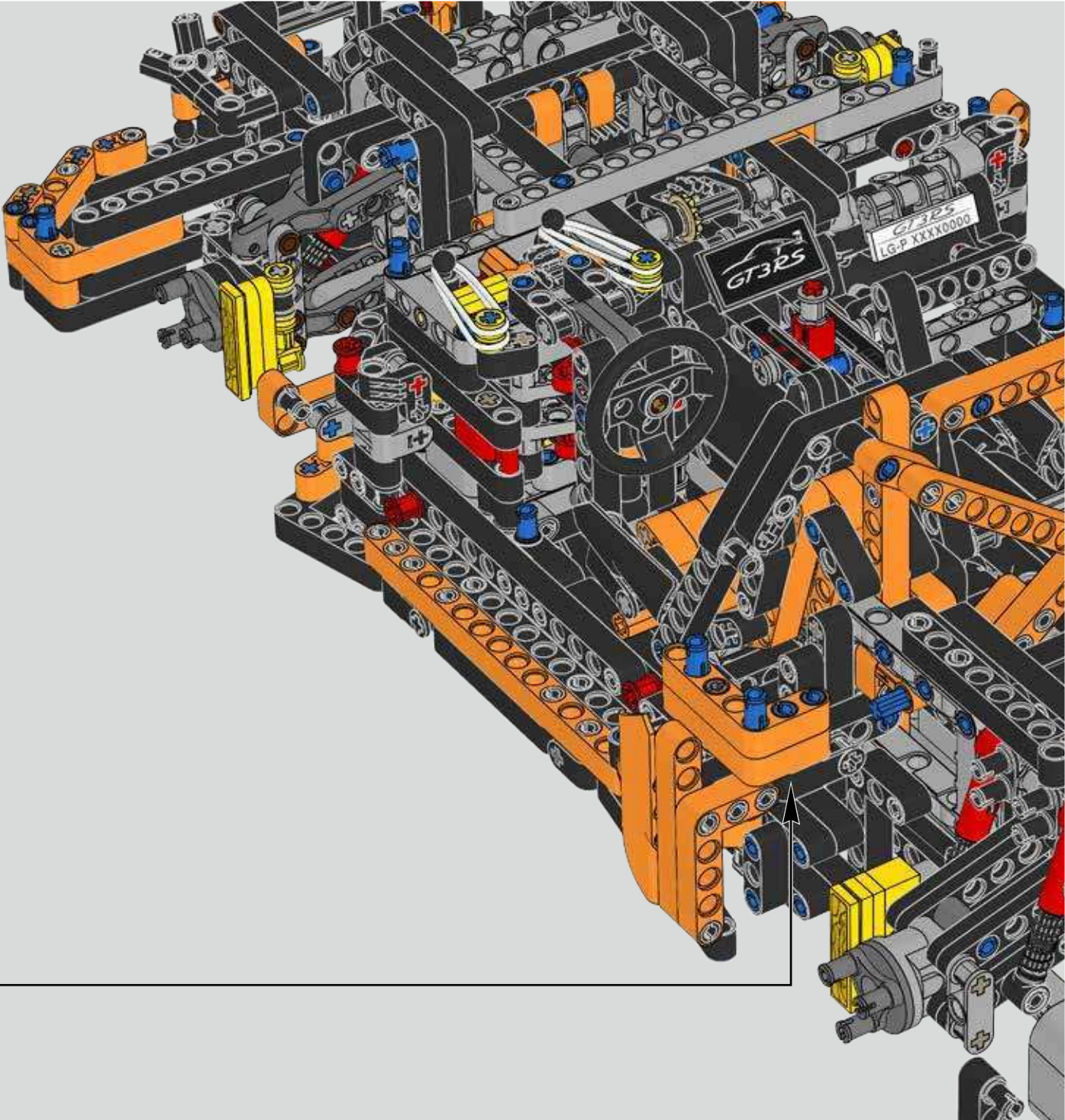
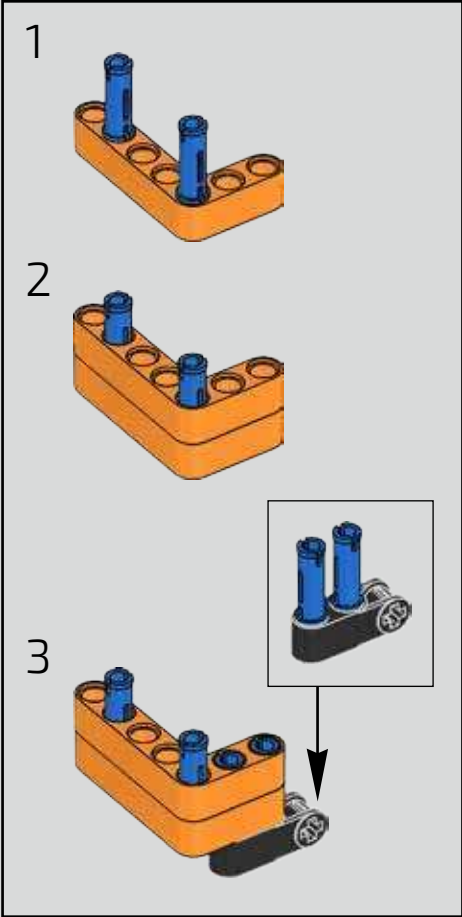

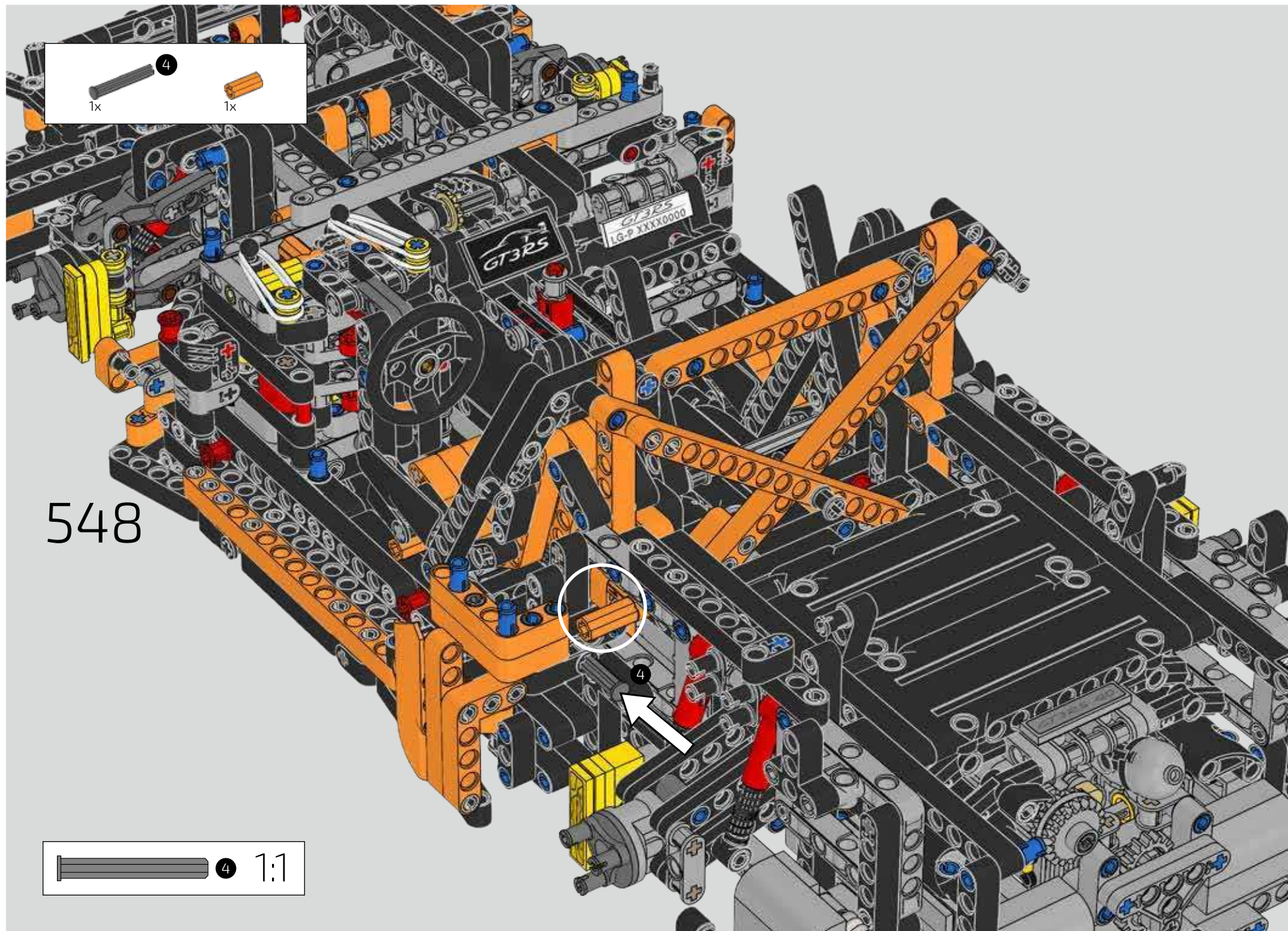

548

 **4** 1:1

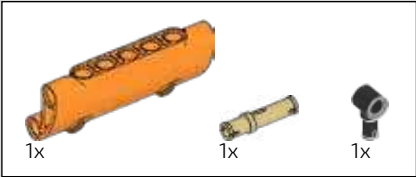

549

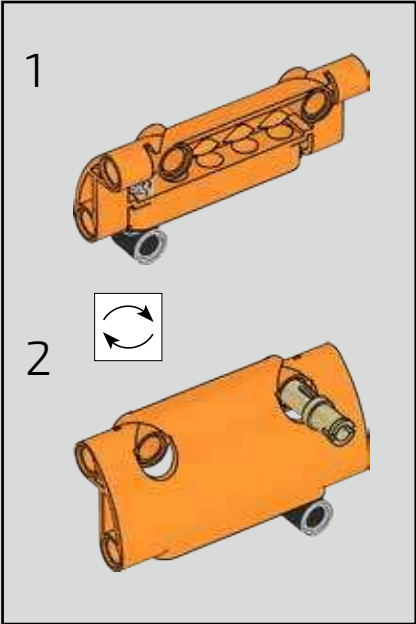
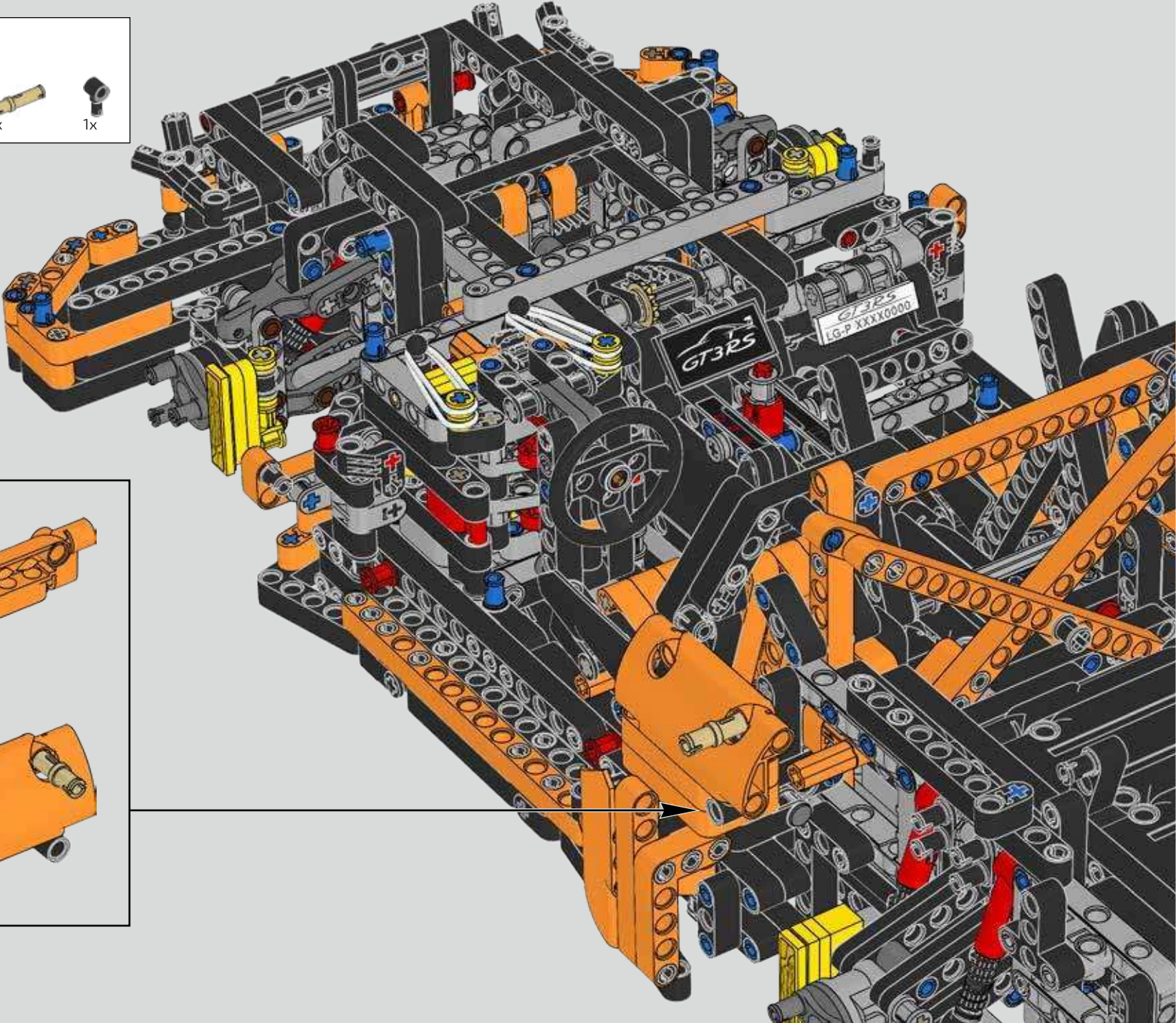

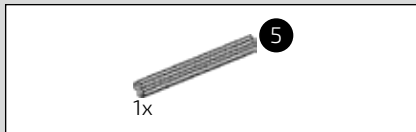

550

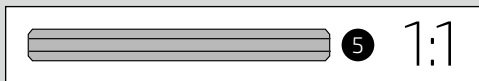
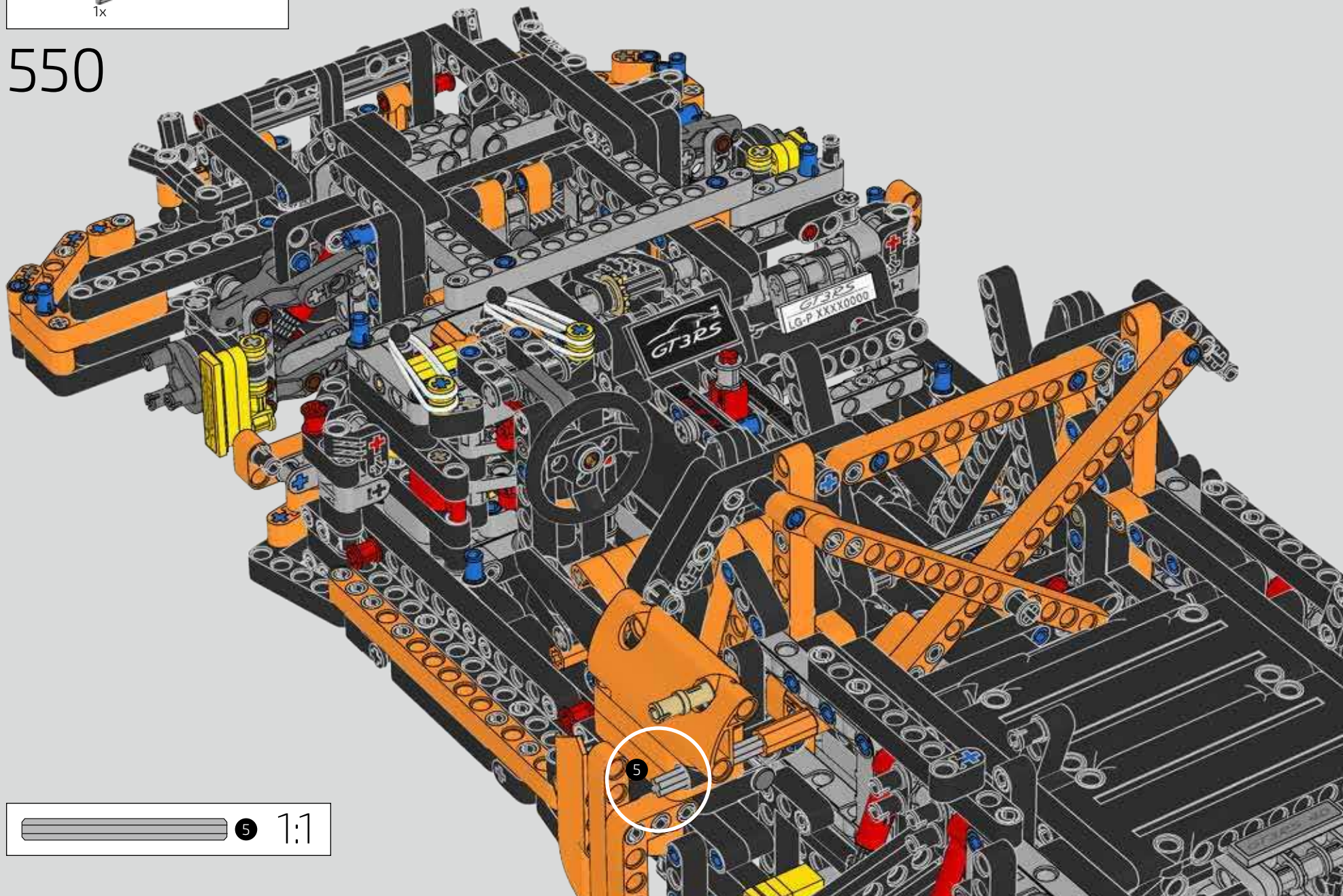



551

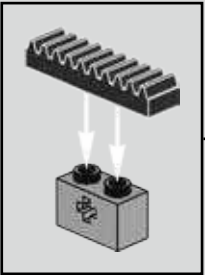
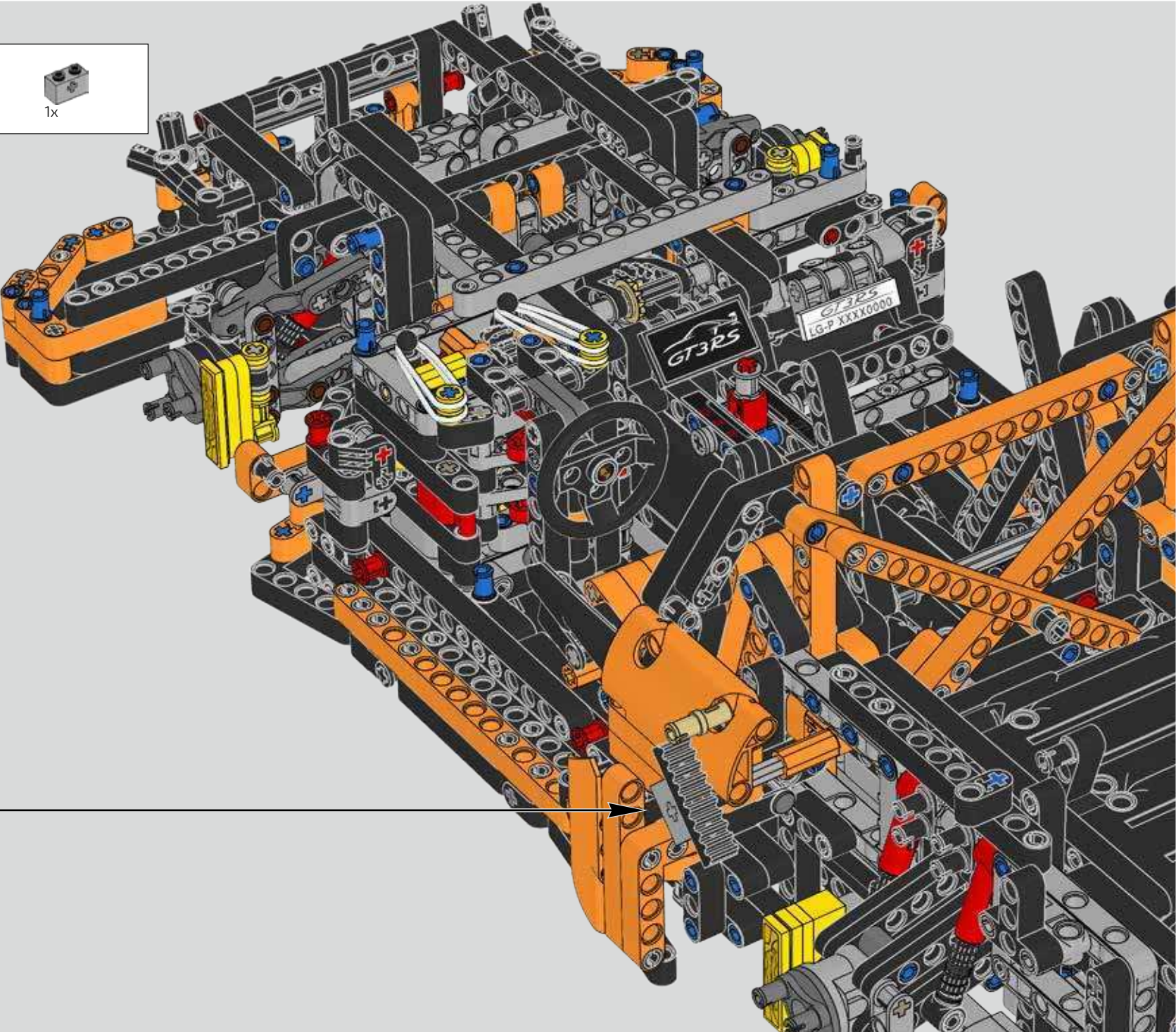

552

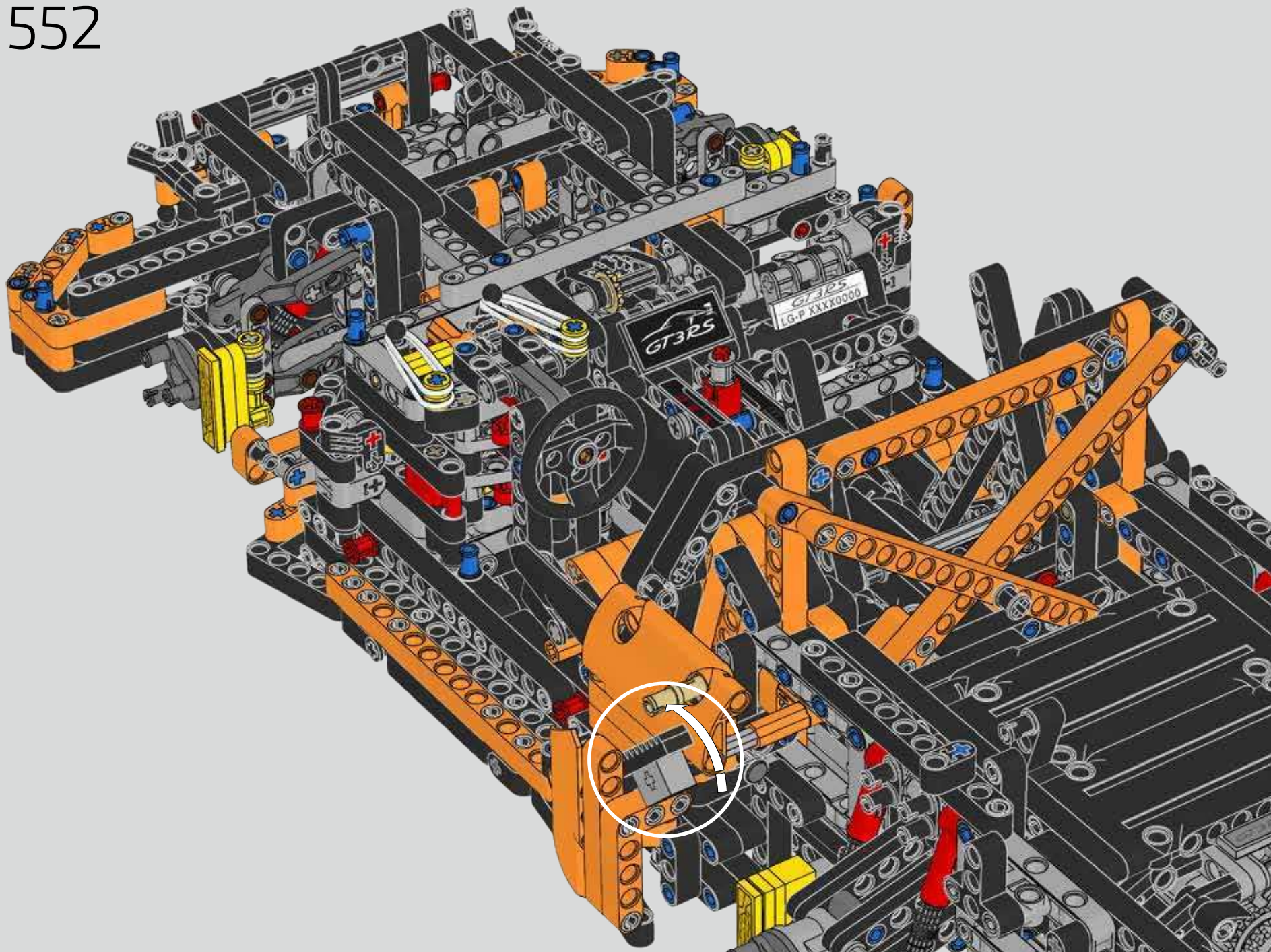

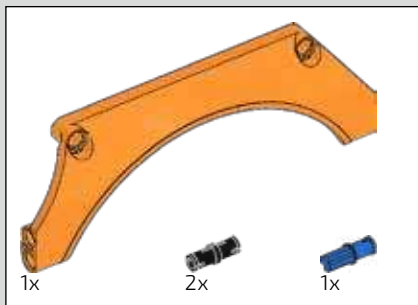

553

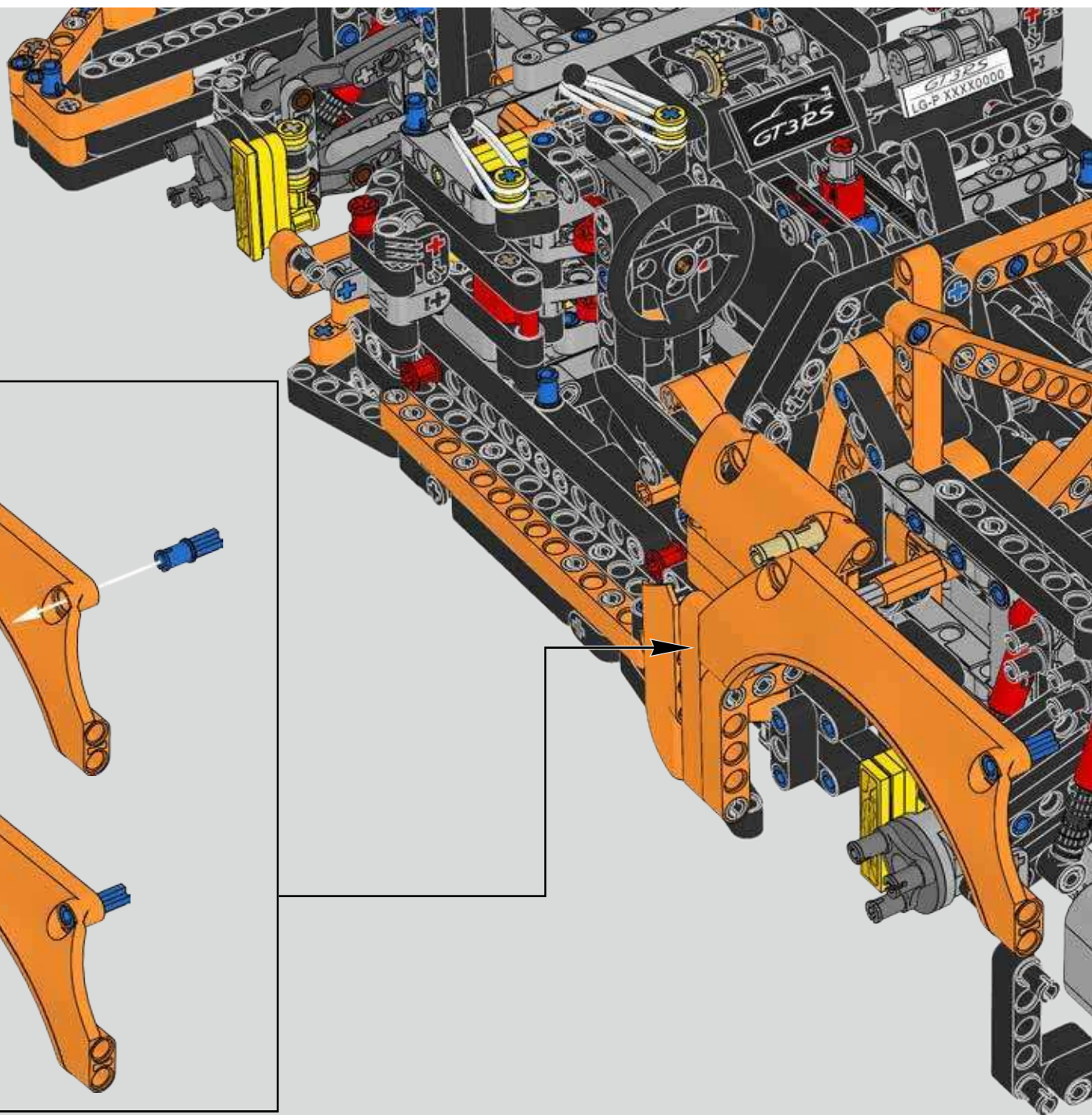
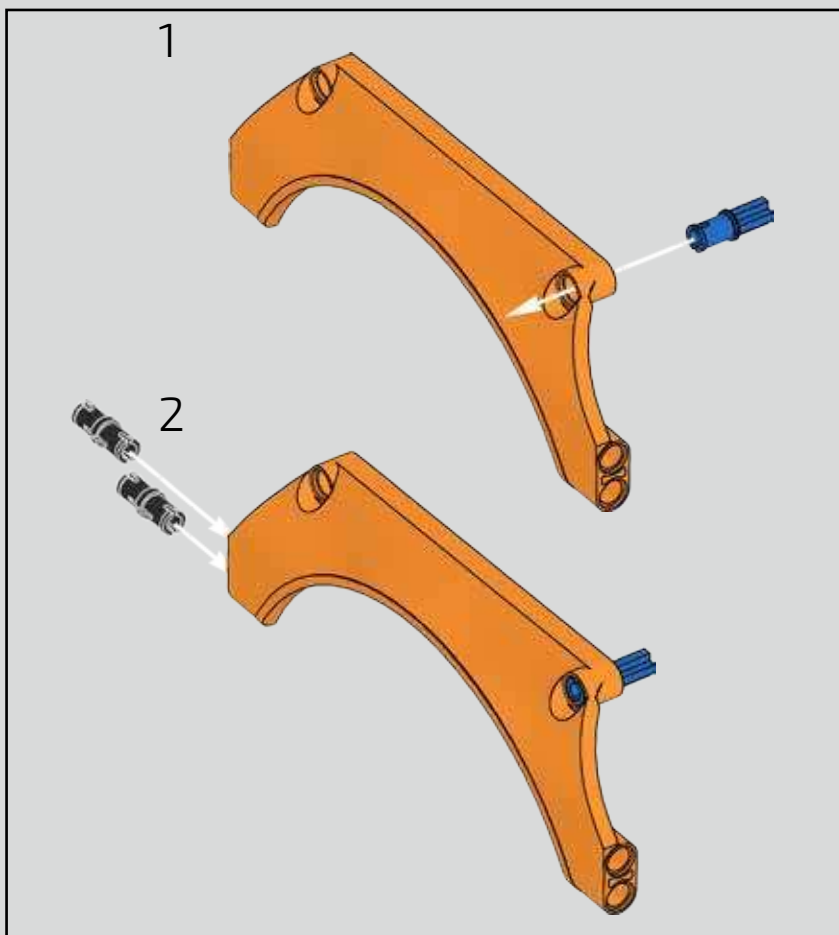

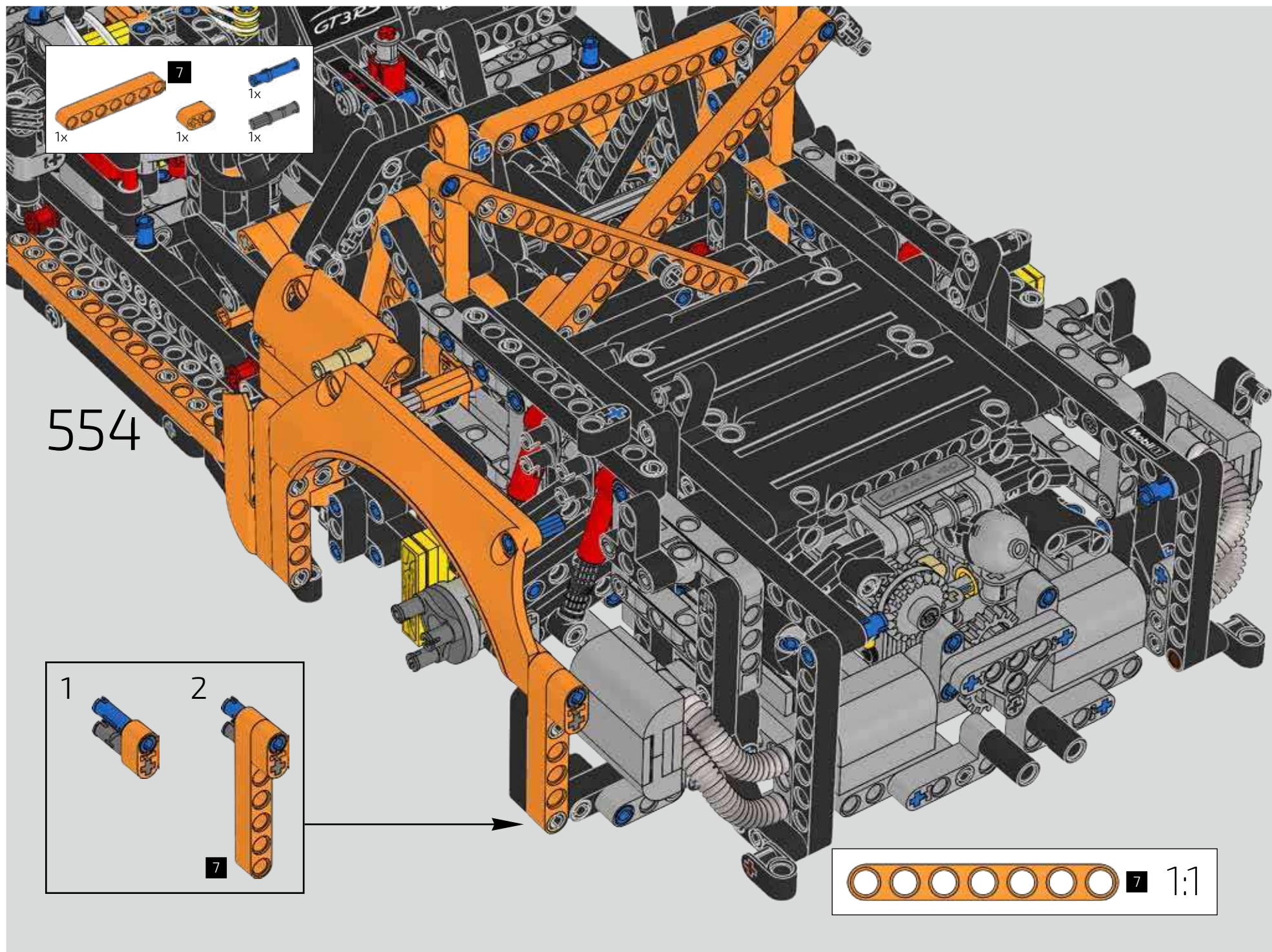

554

1

2

7

7 1:1

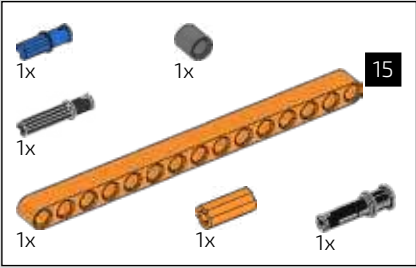

555

1

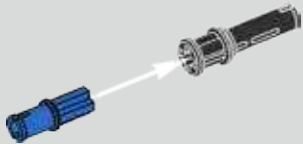

2

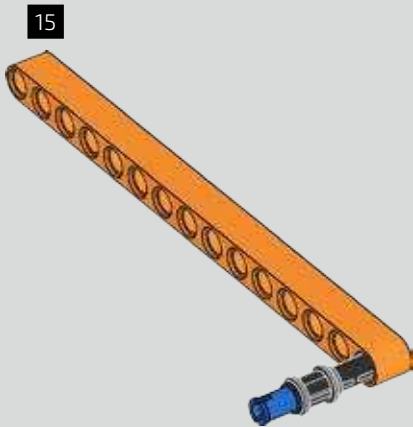

3

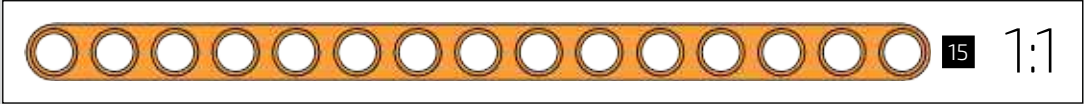
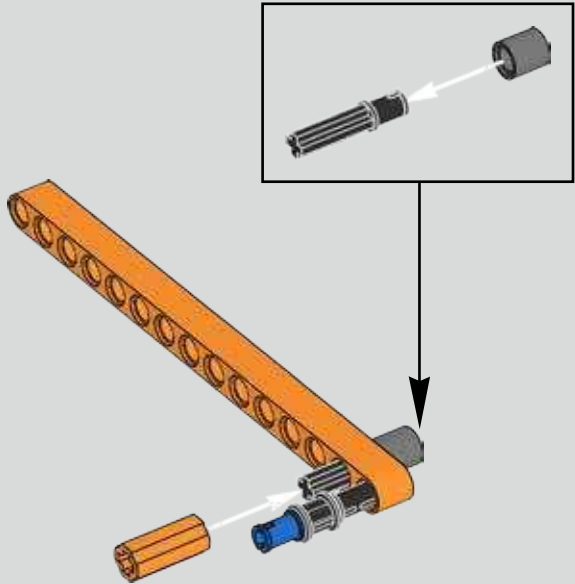

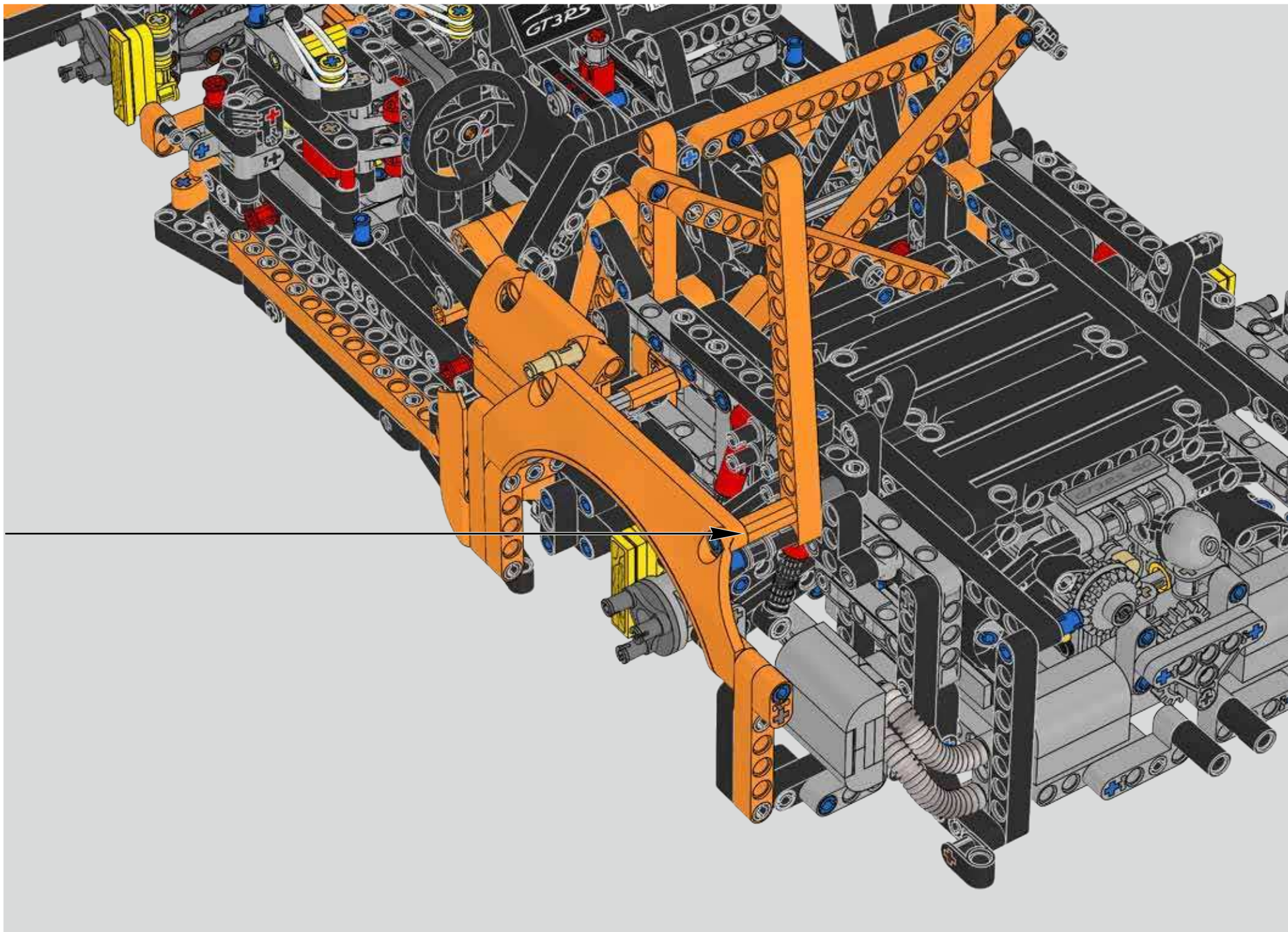

556

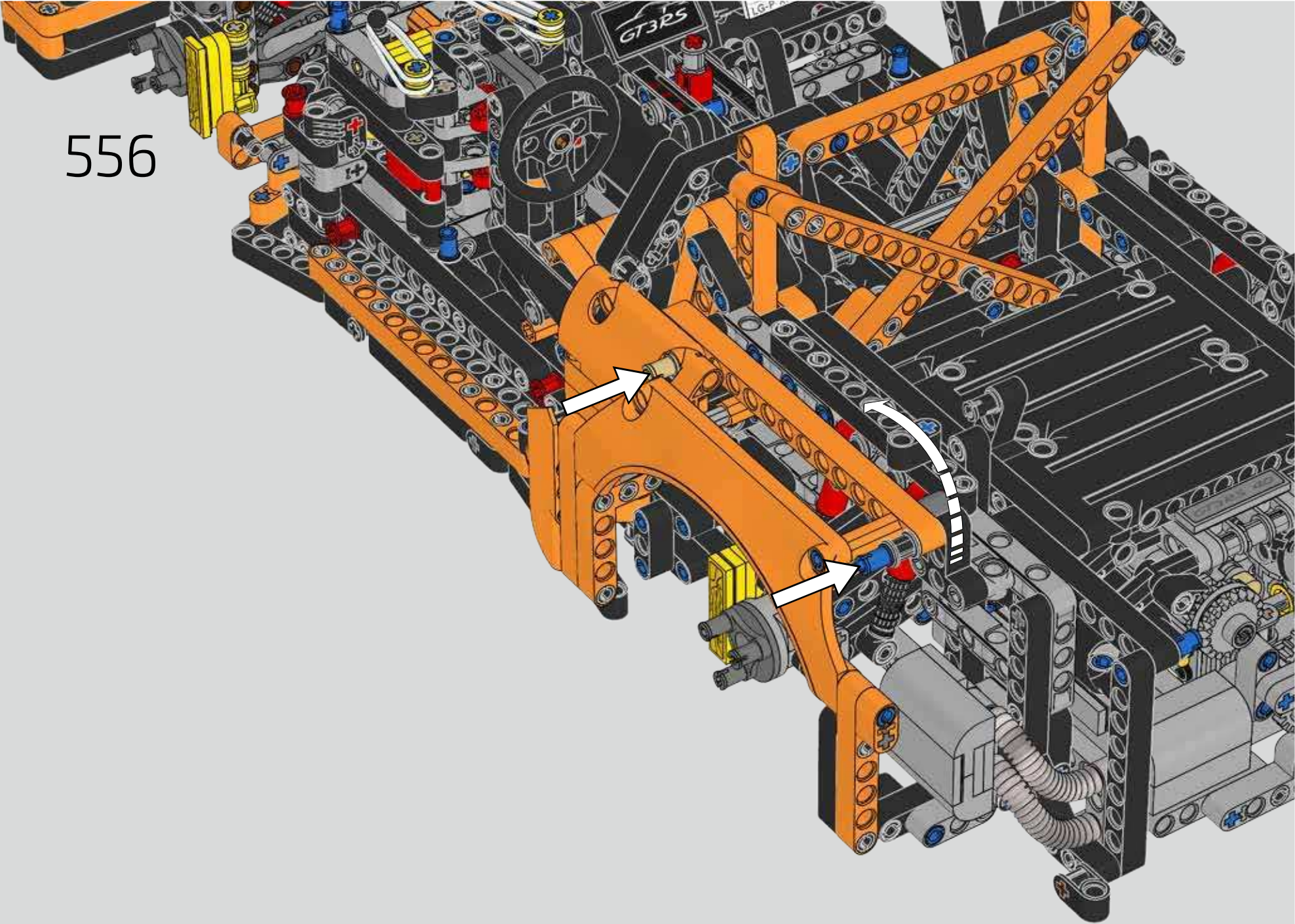

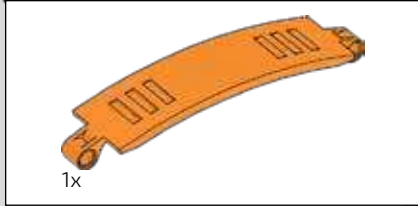

557

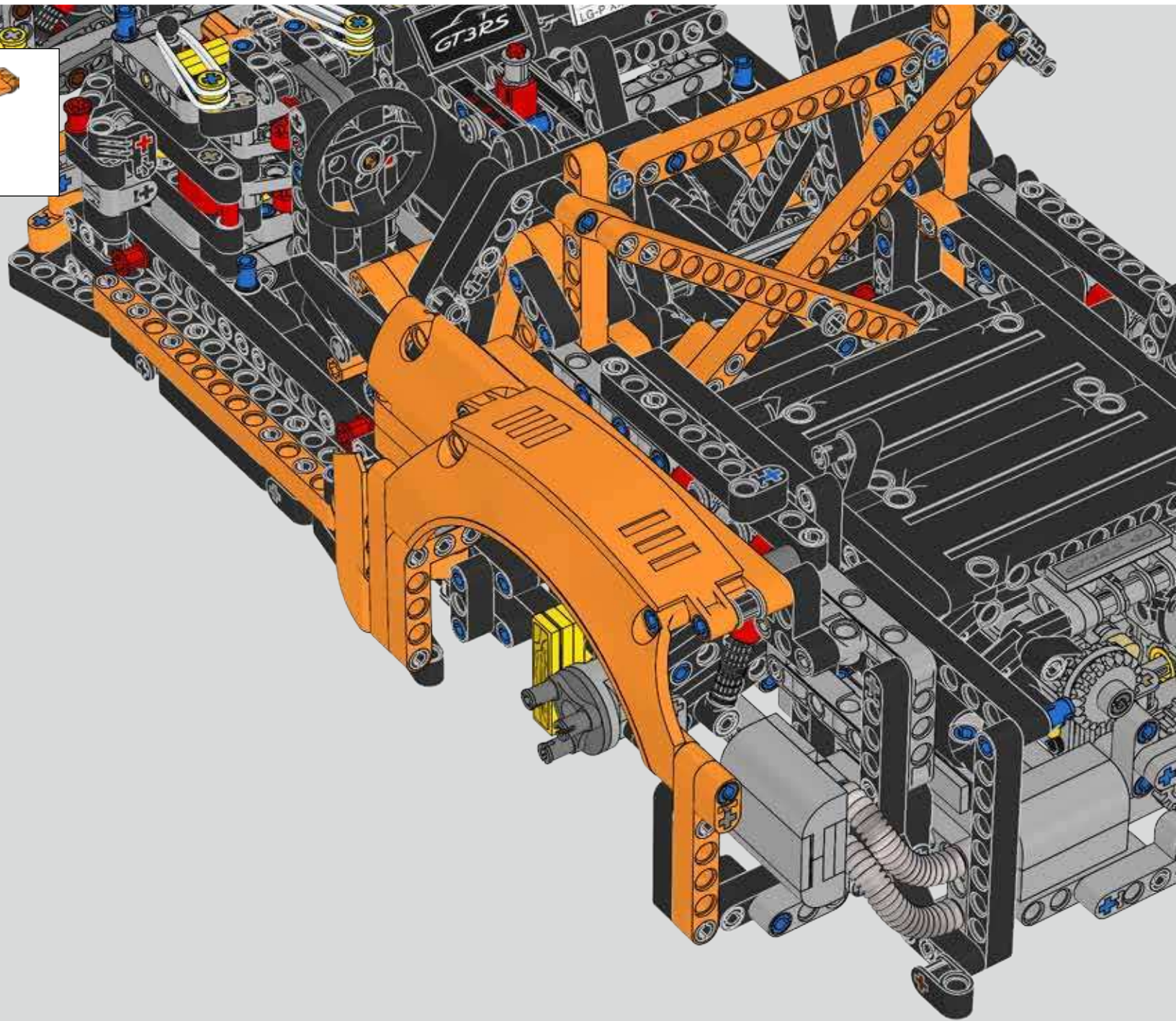

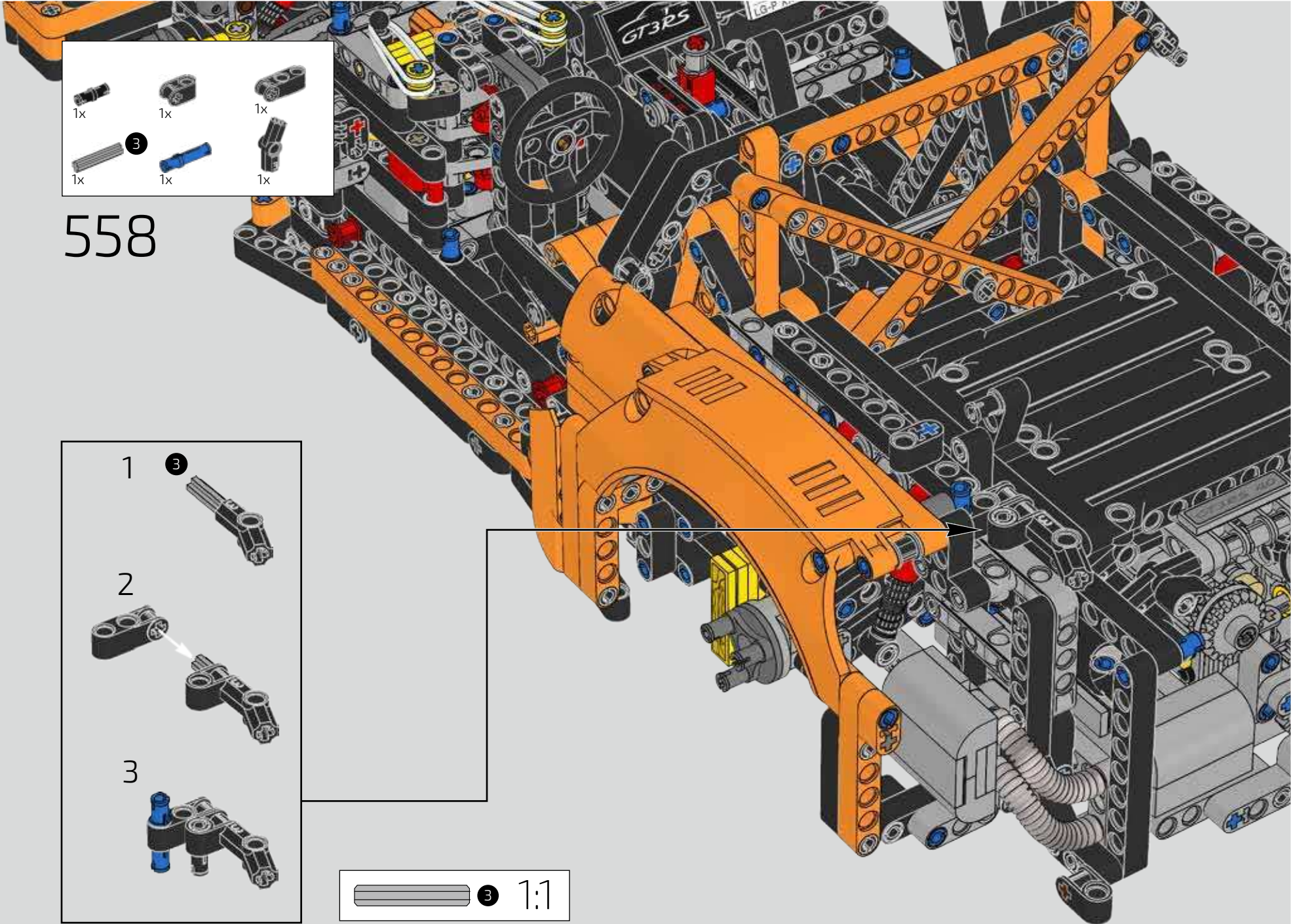

- 1x
- 1x
- 1x
- 1x
- 1x
- 1x

558

1

2

3

3 1:1

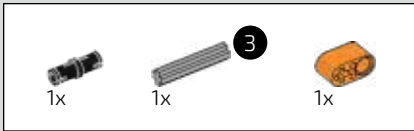

559

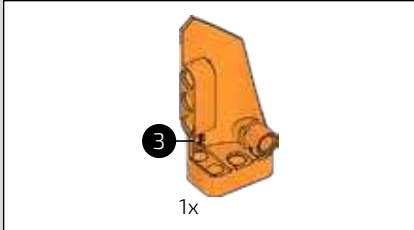
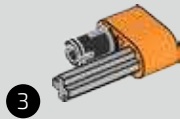

560

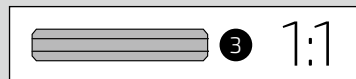
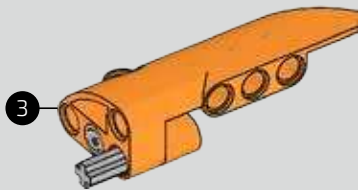

561

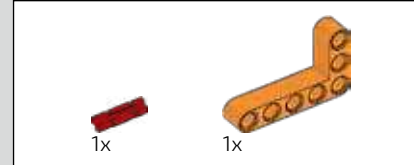
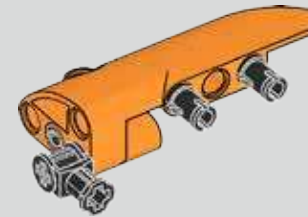

562

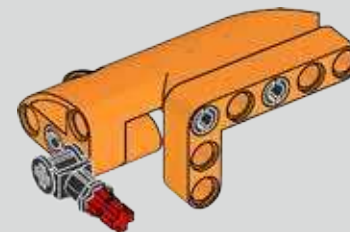

563

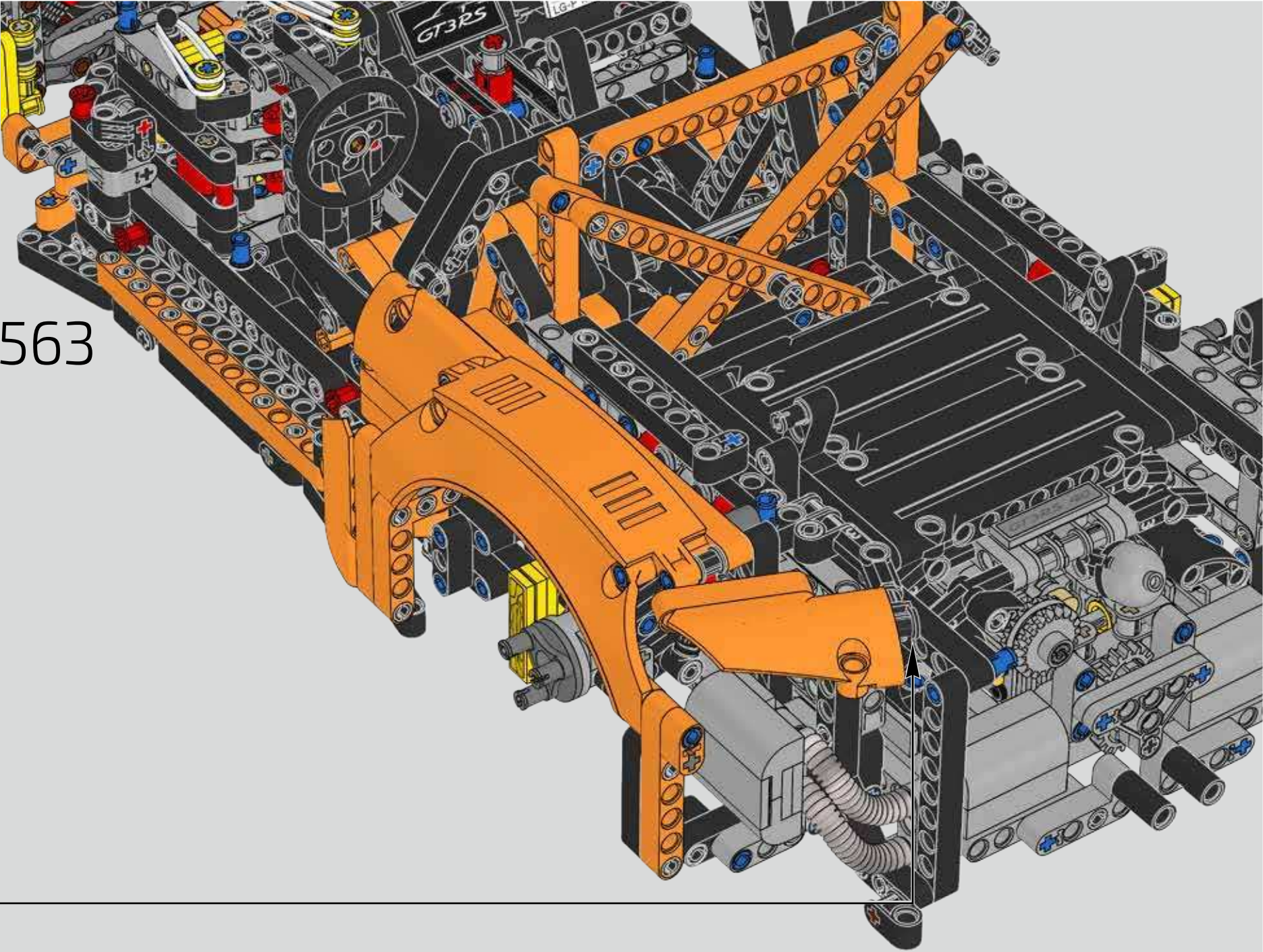

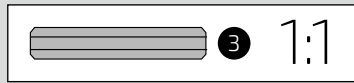
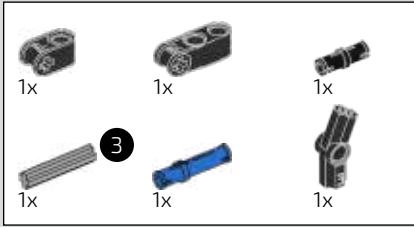



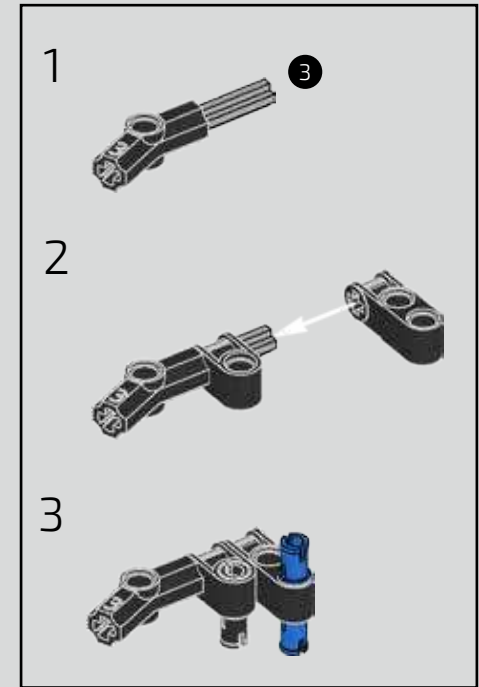
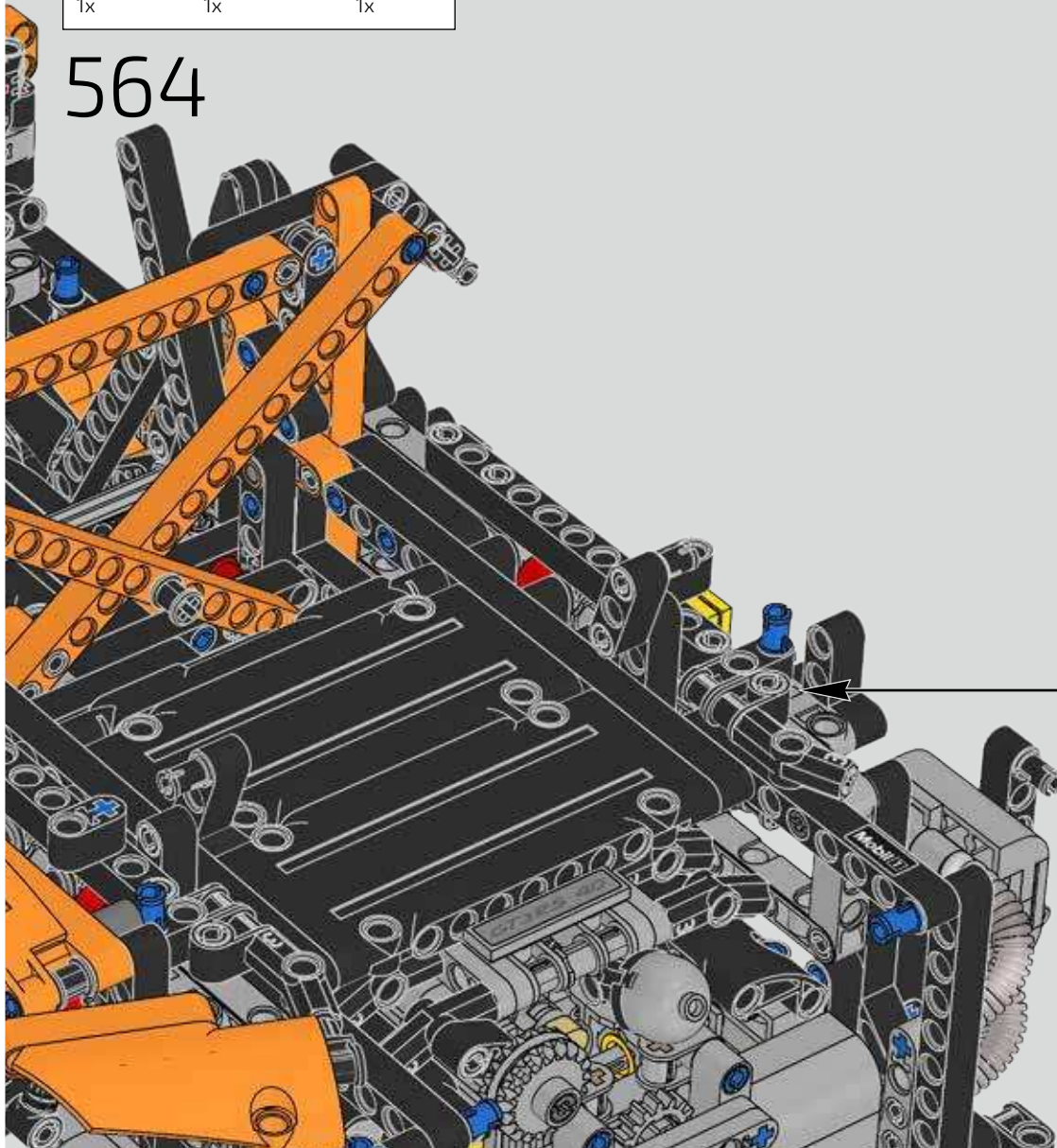

564



565

	
2x	2x

	
	2x

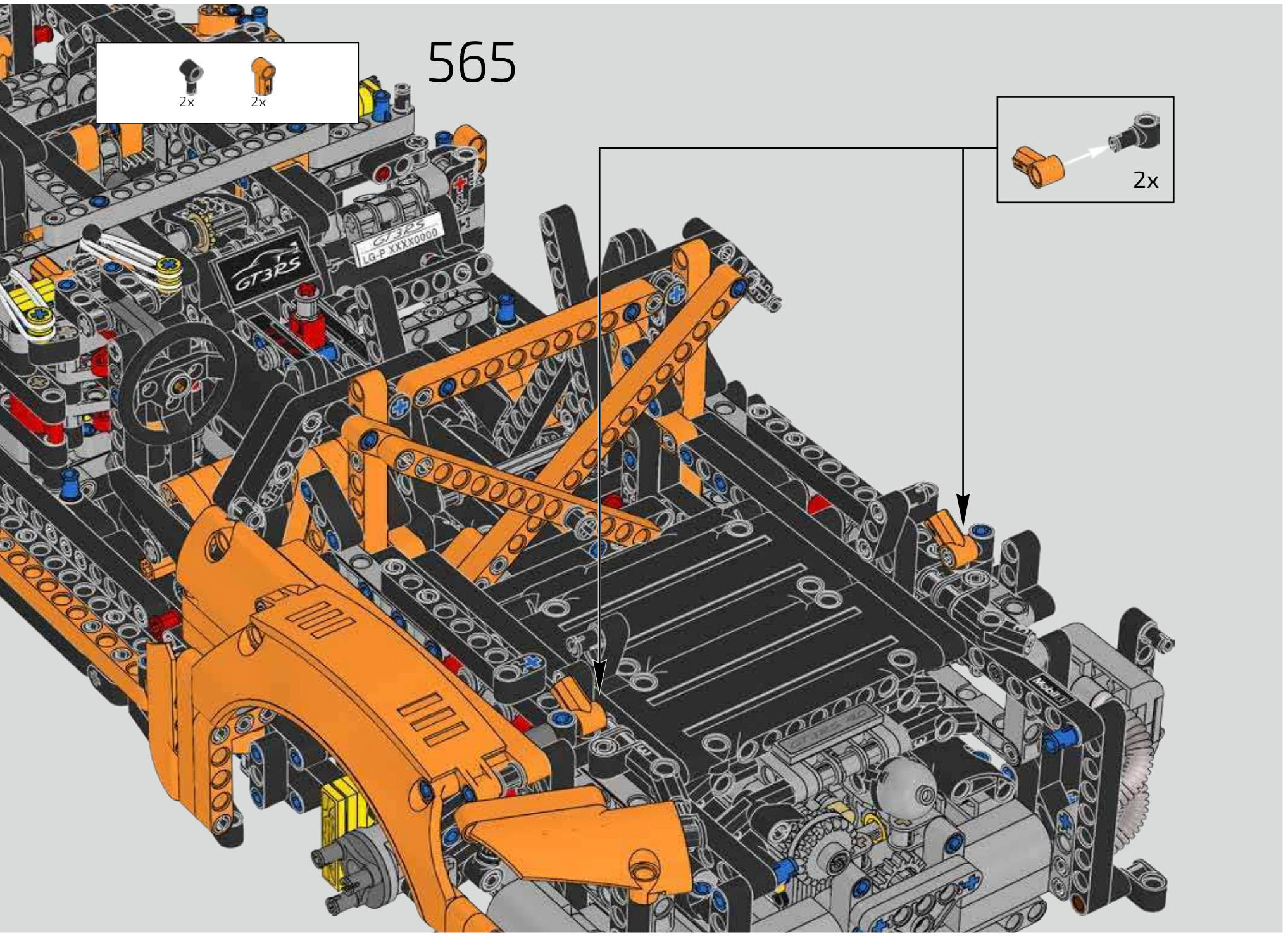

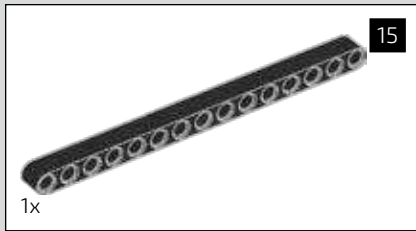

566

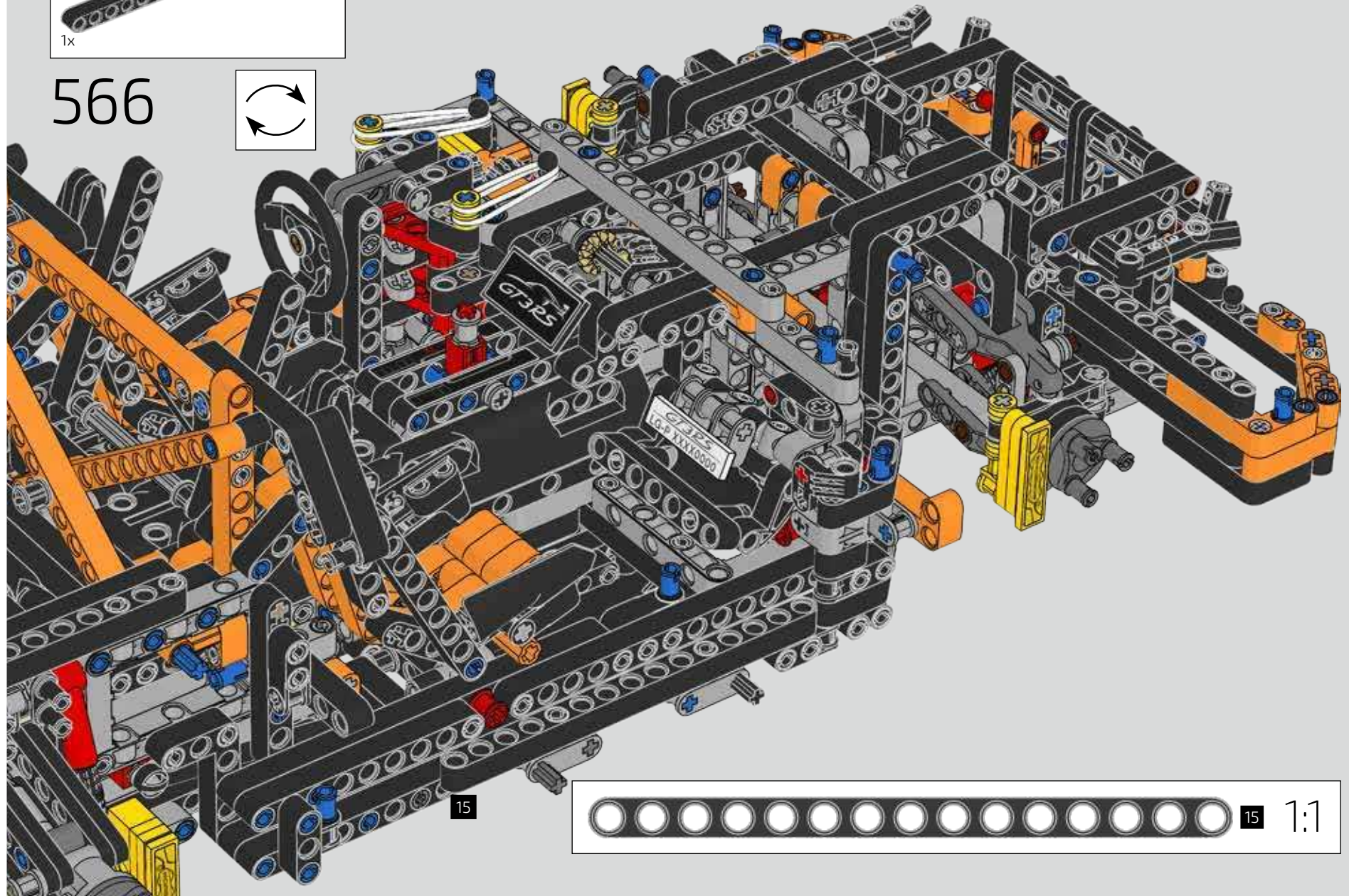
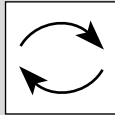

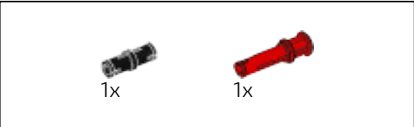

567

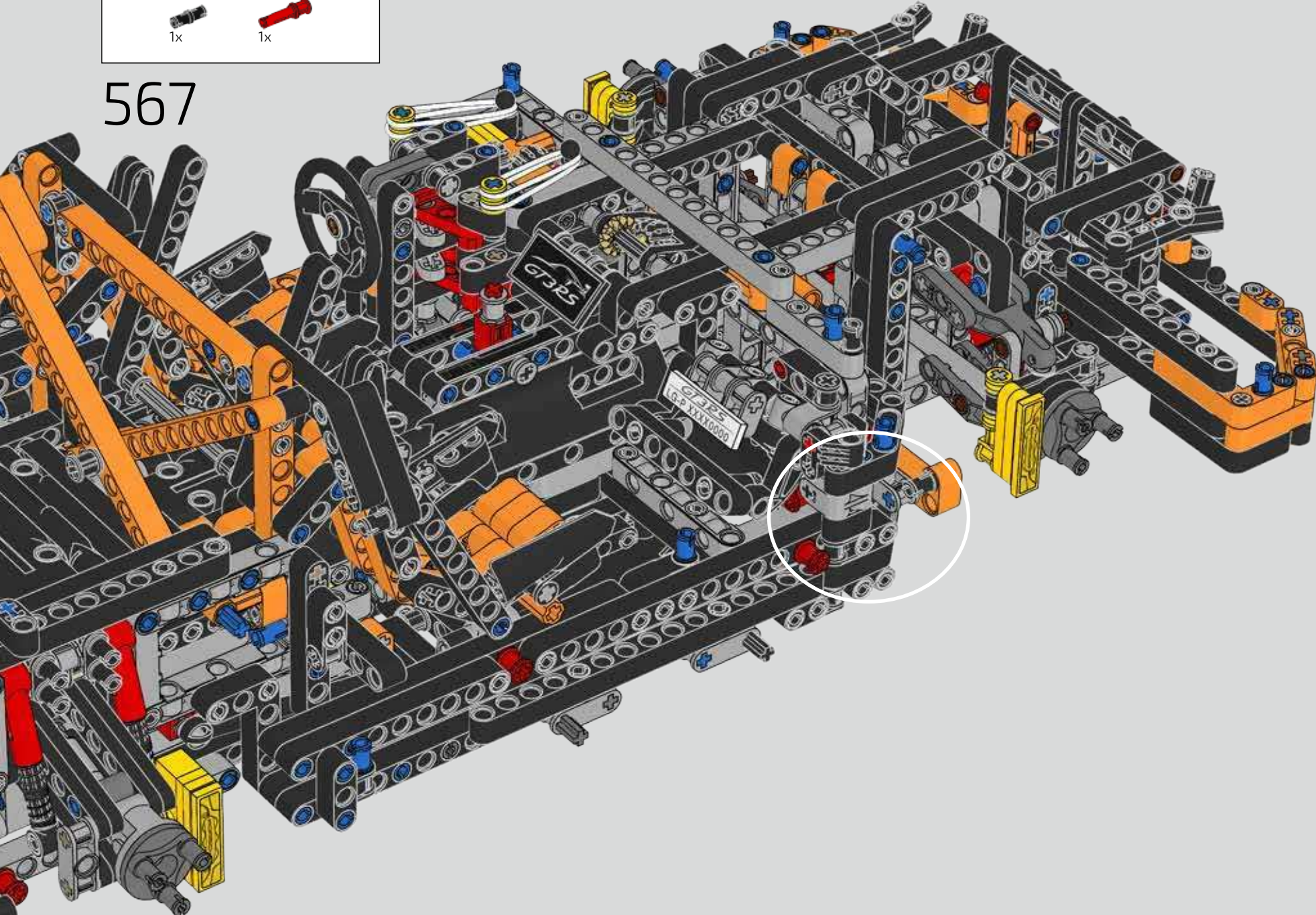

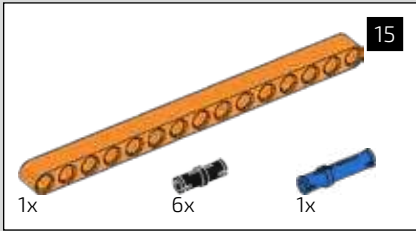
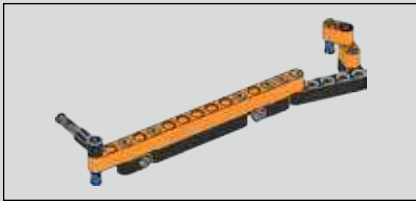

568

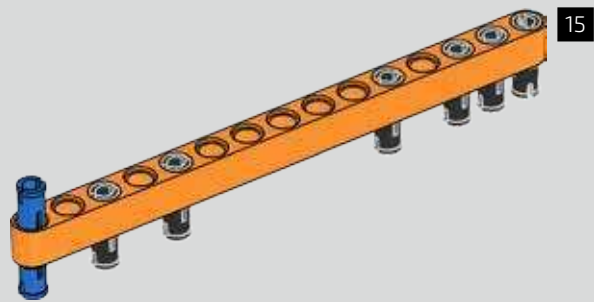

569

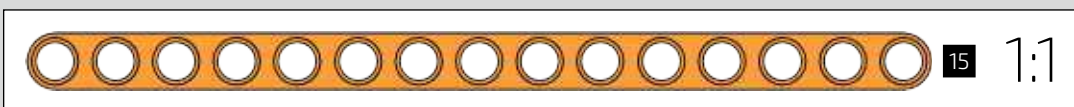
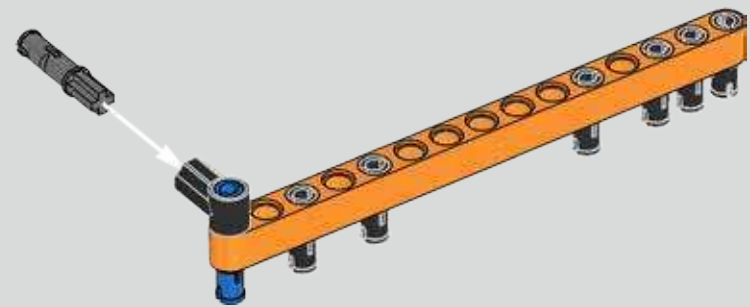

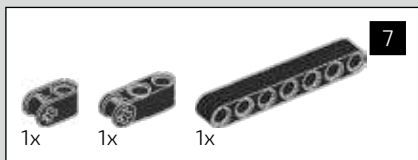

570

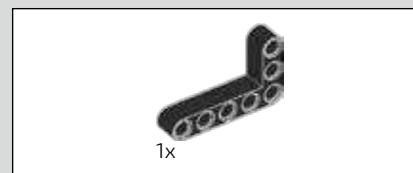
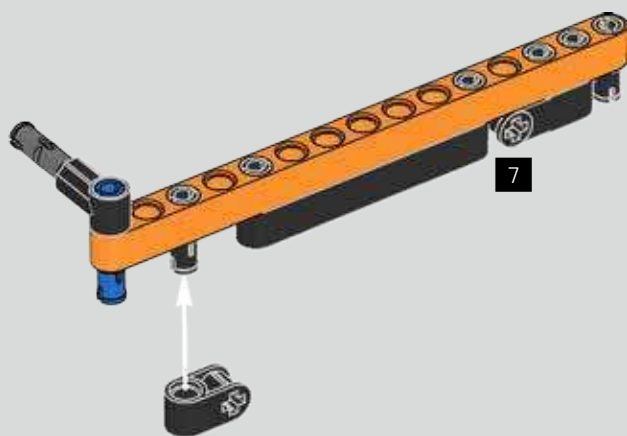

571

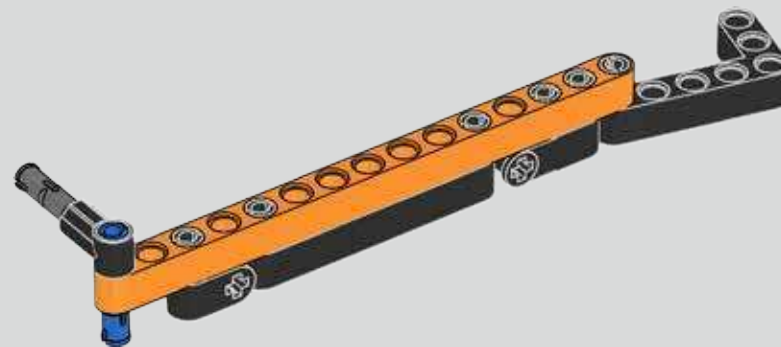



572

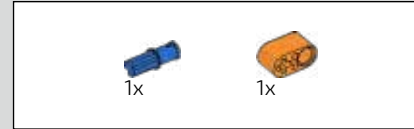
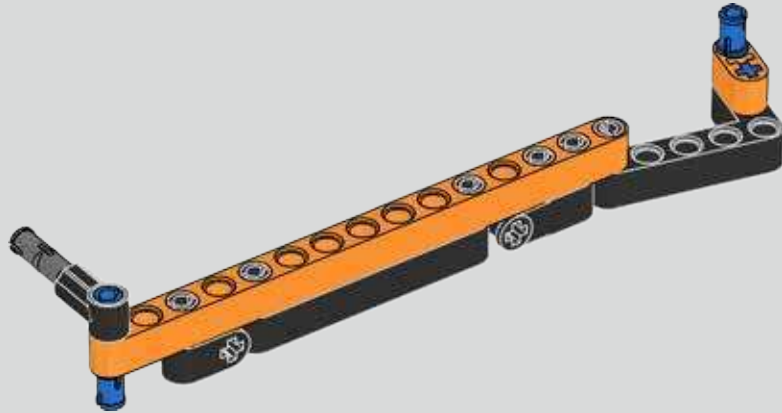
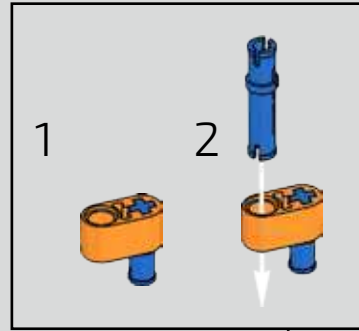

573

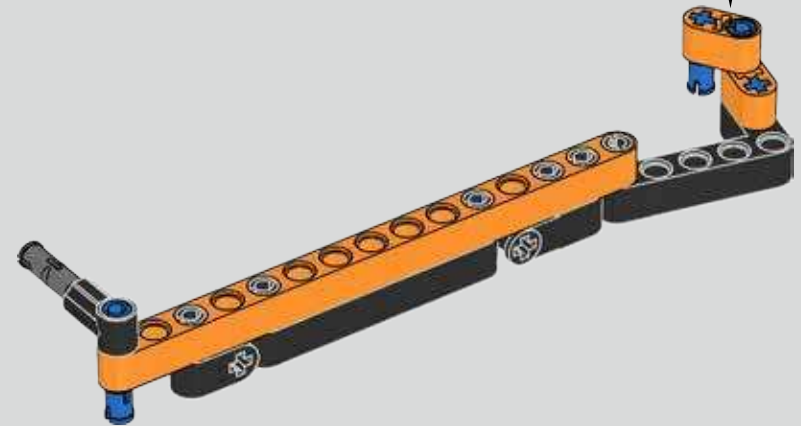
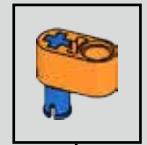

574

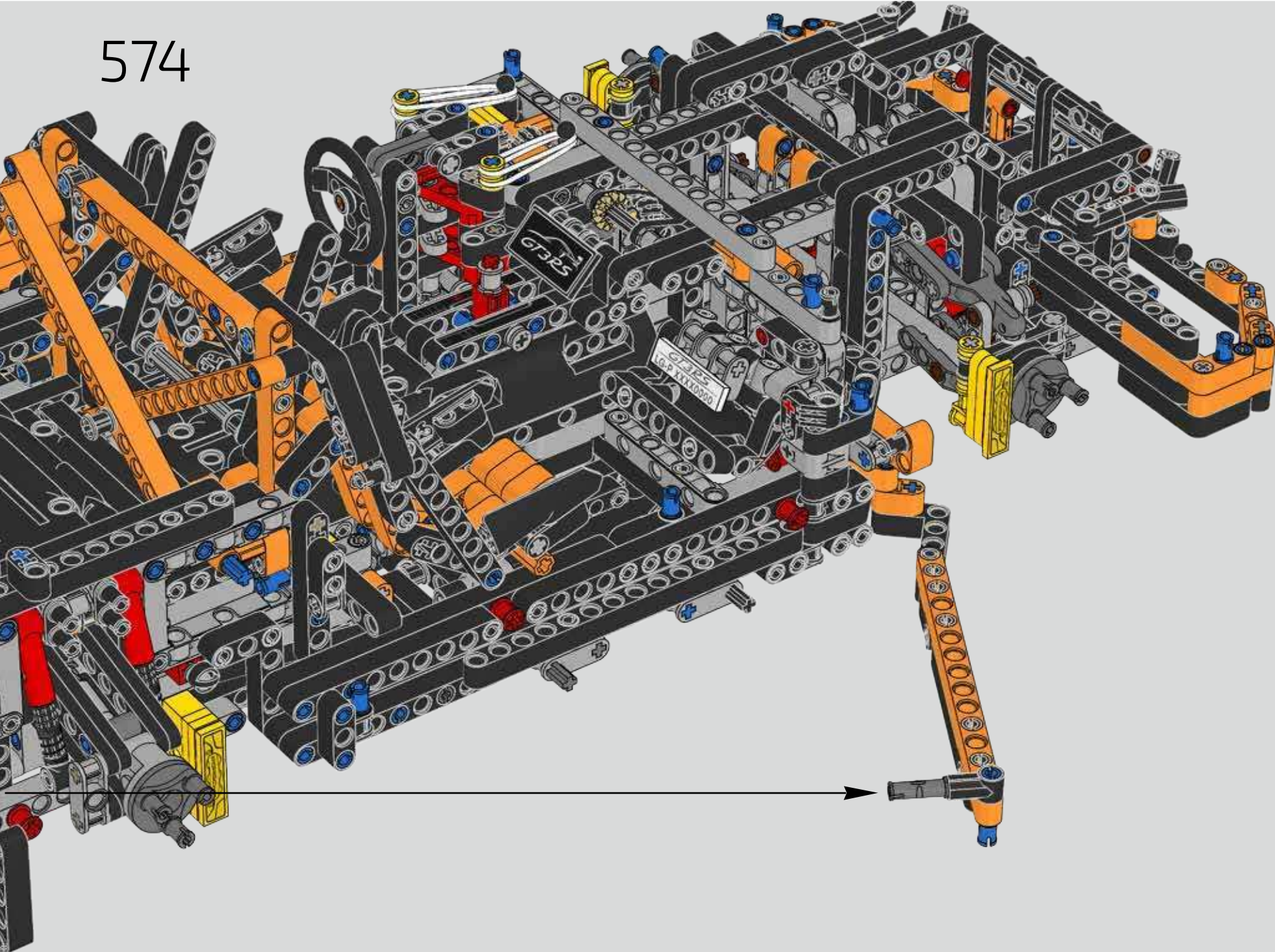

575

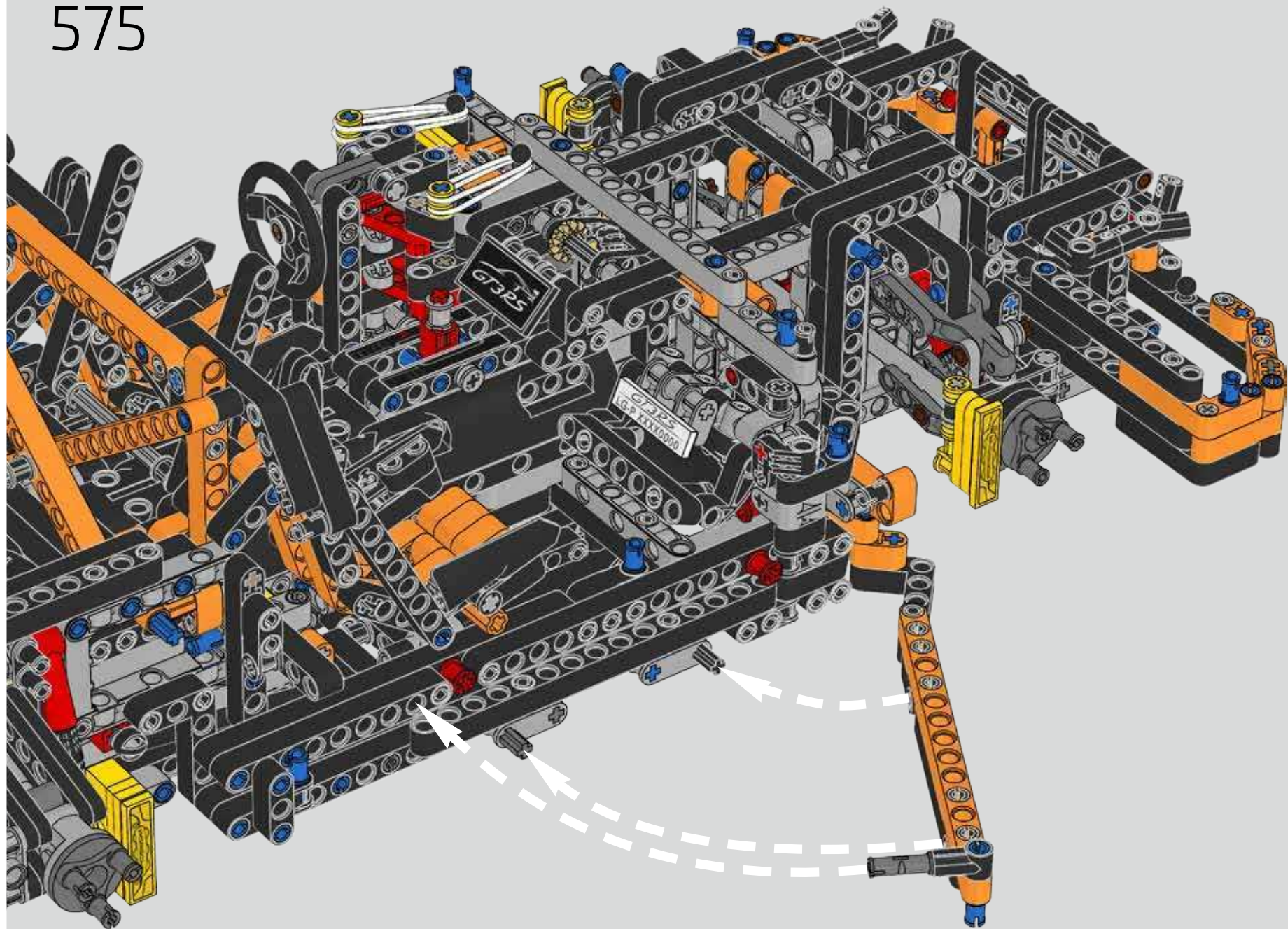

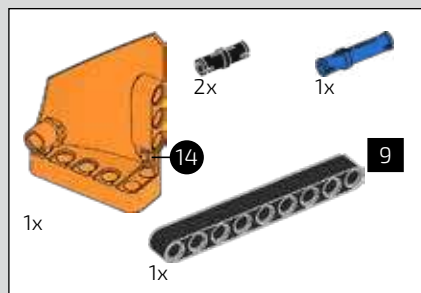

576

1

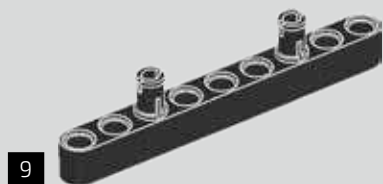

2

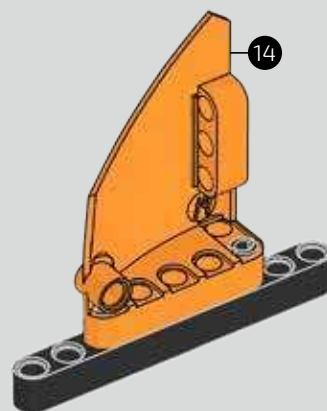

3

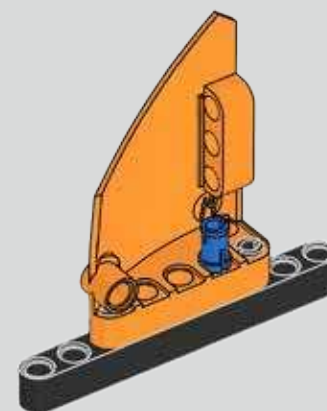

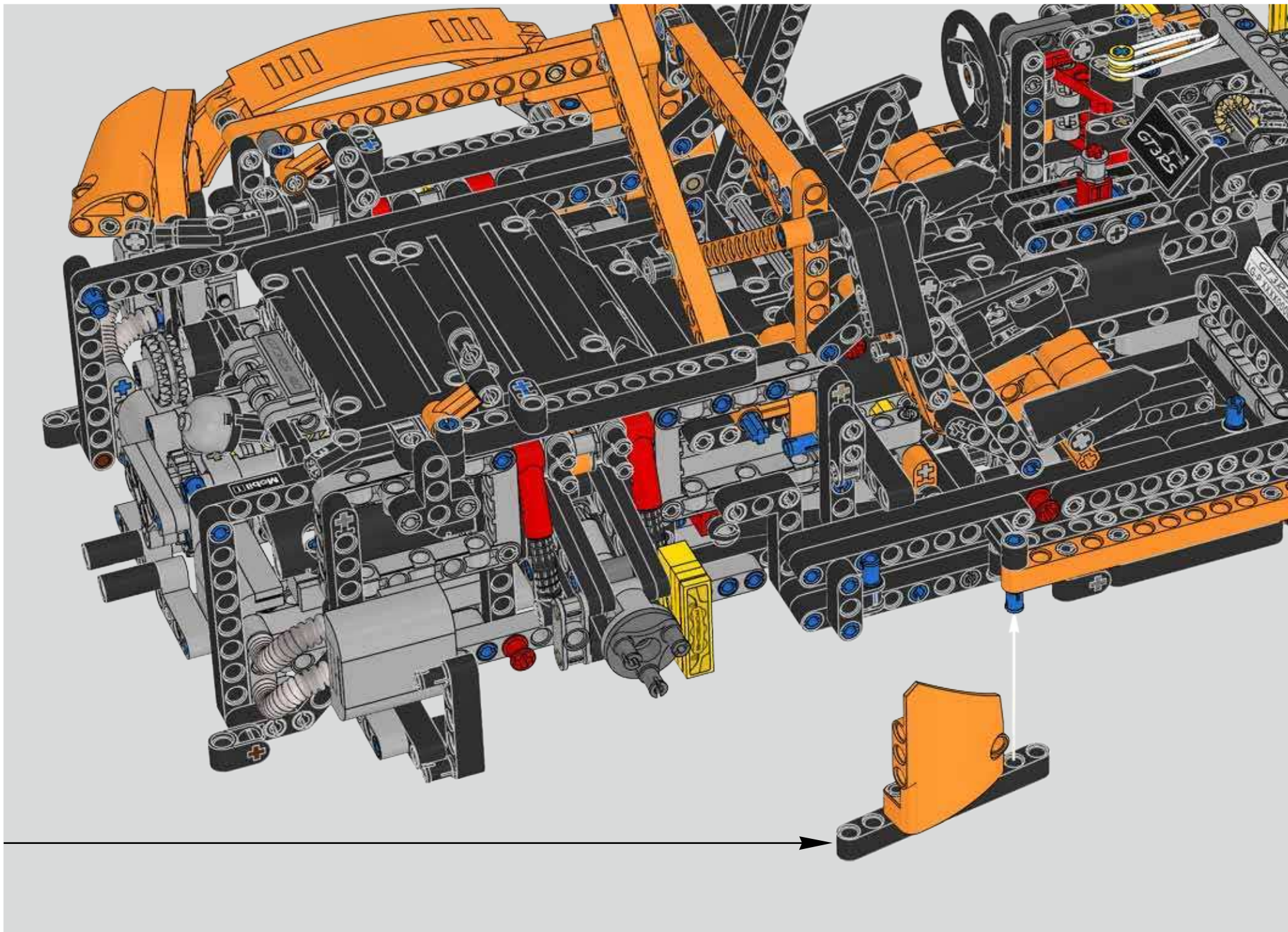

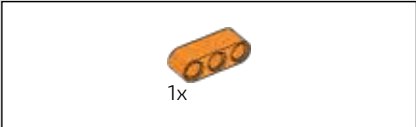

577

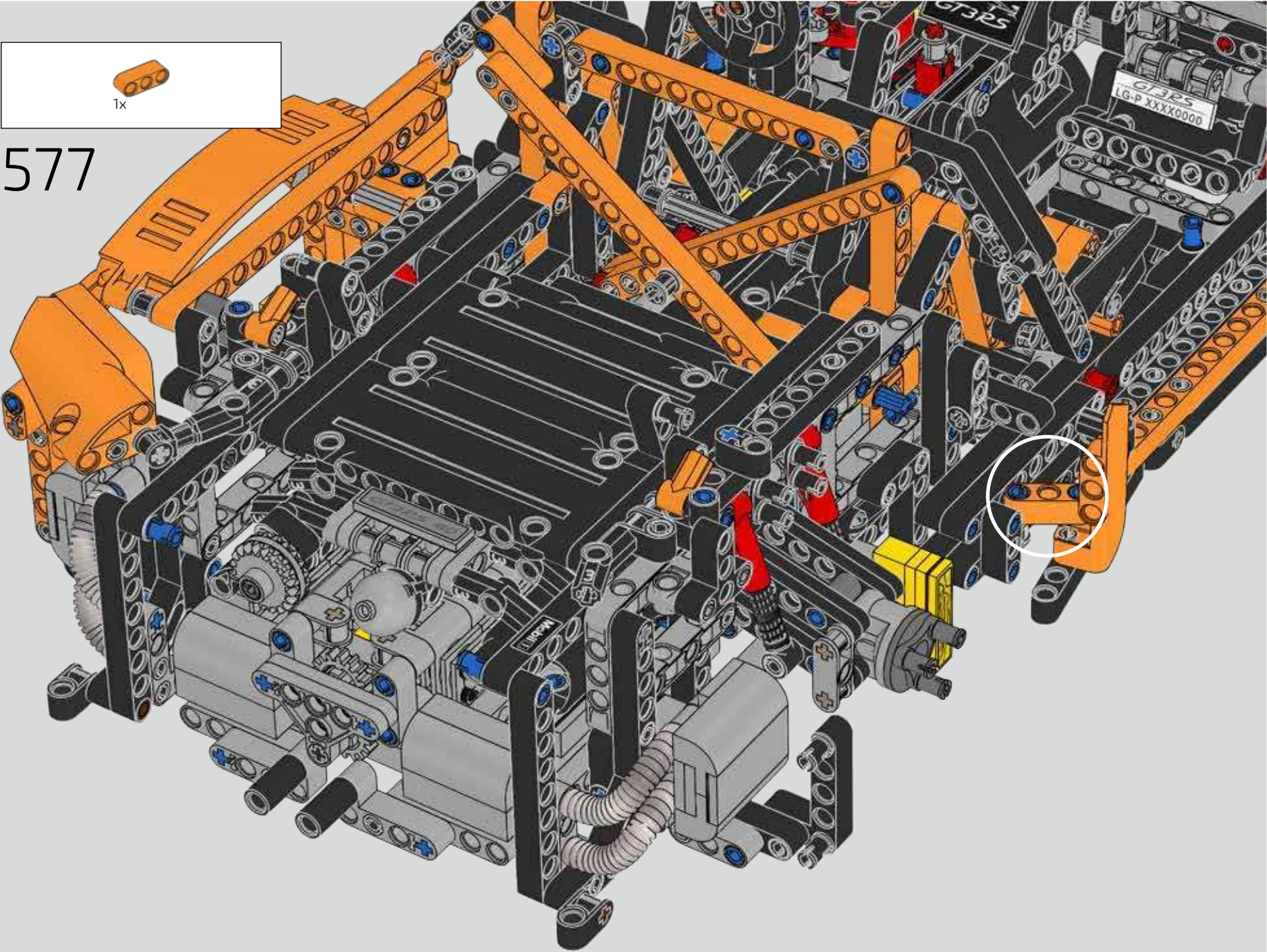



578

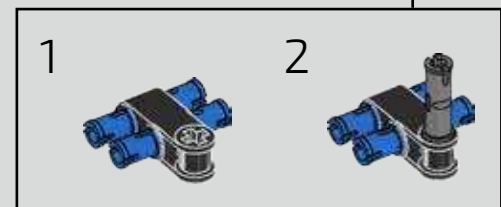
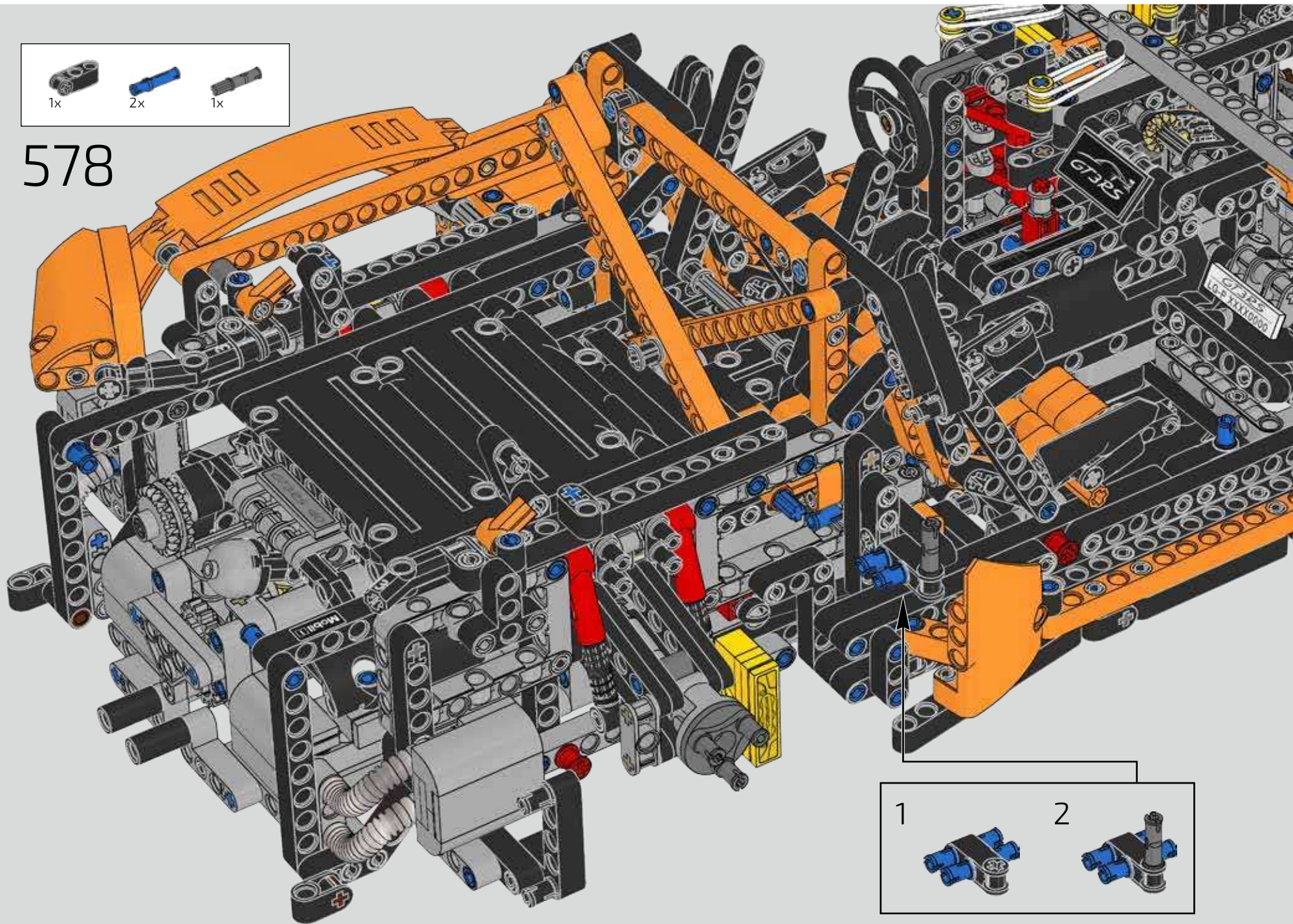

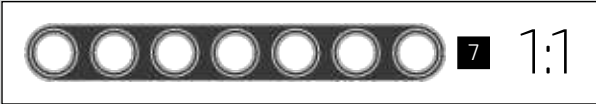
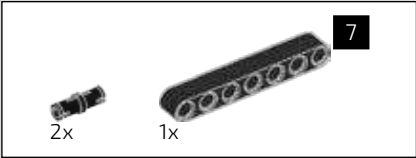

579

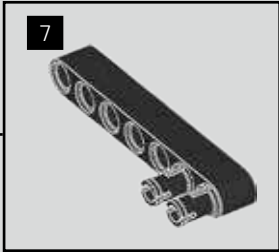
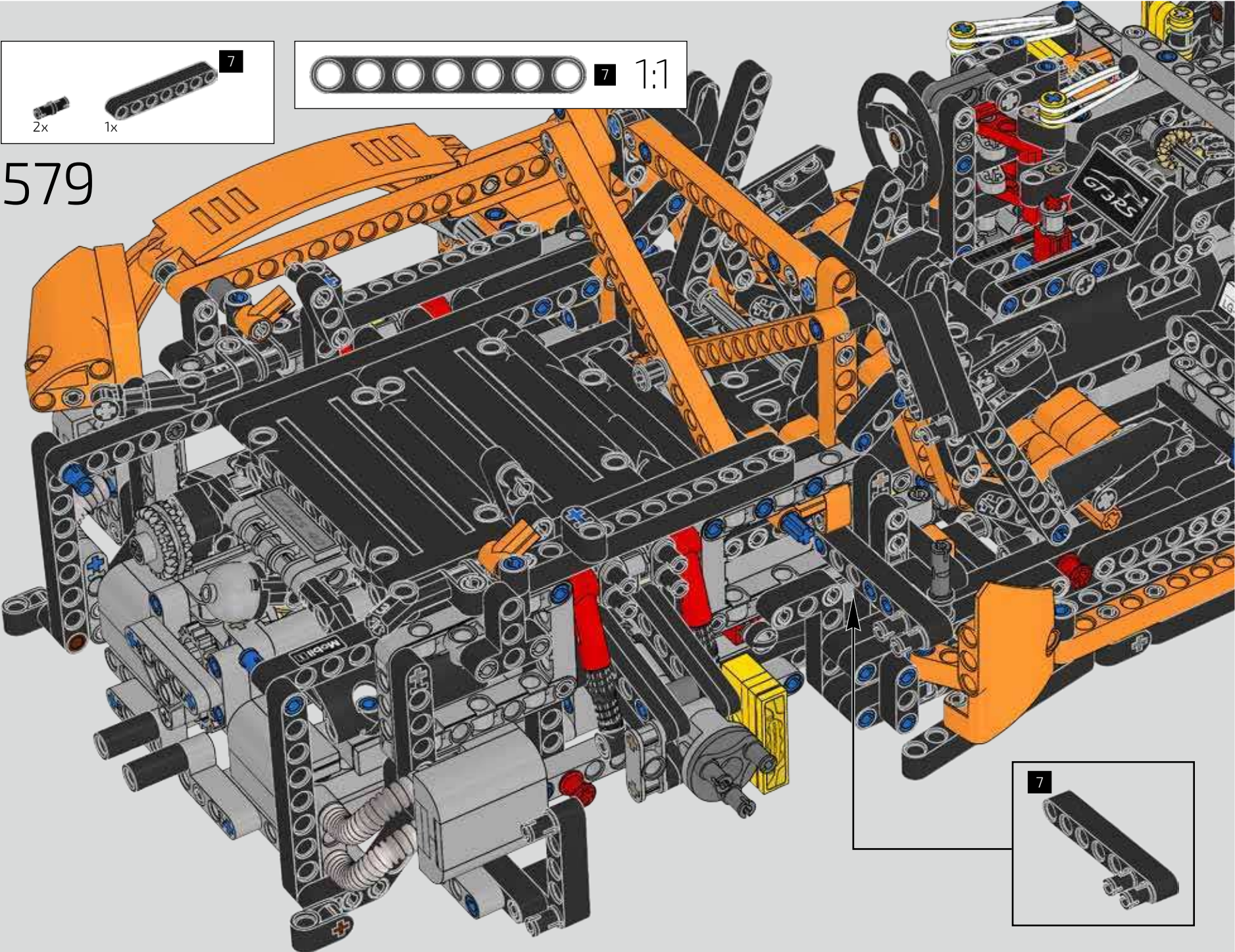

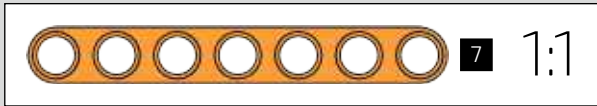
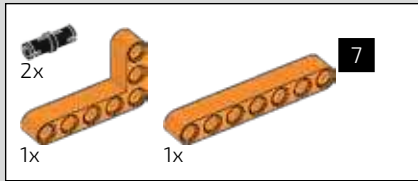

580

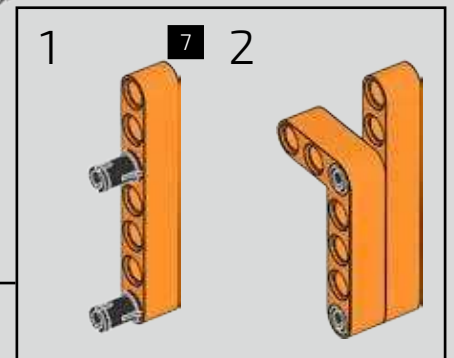
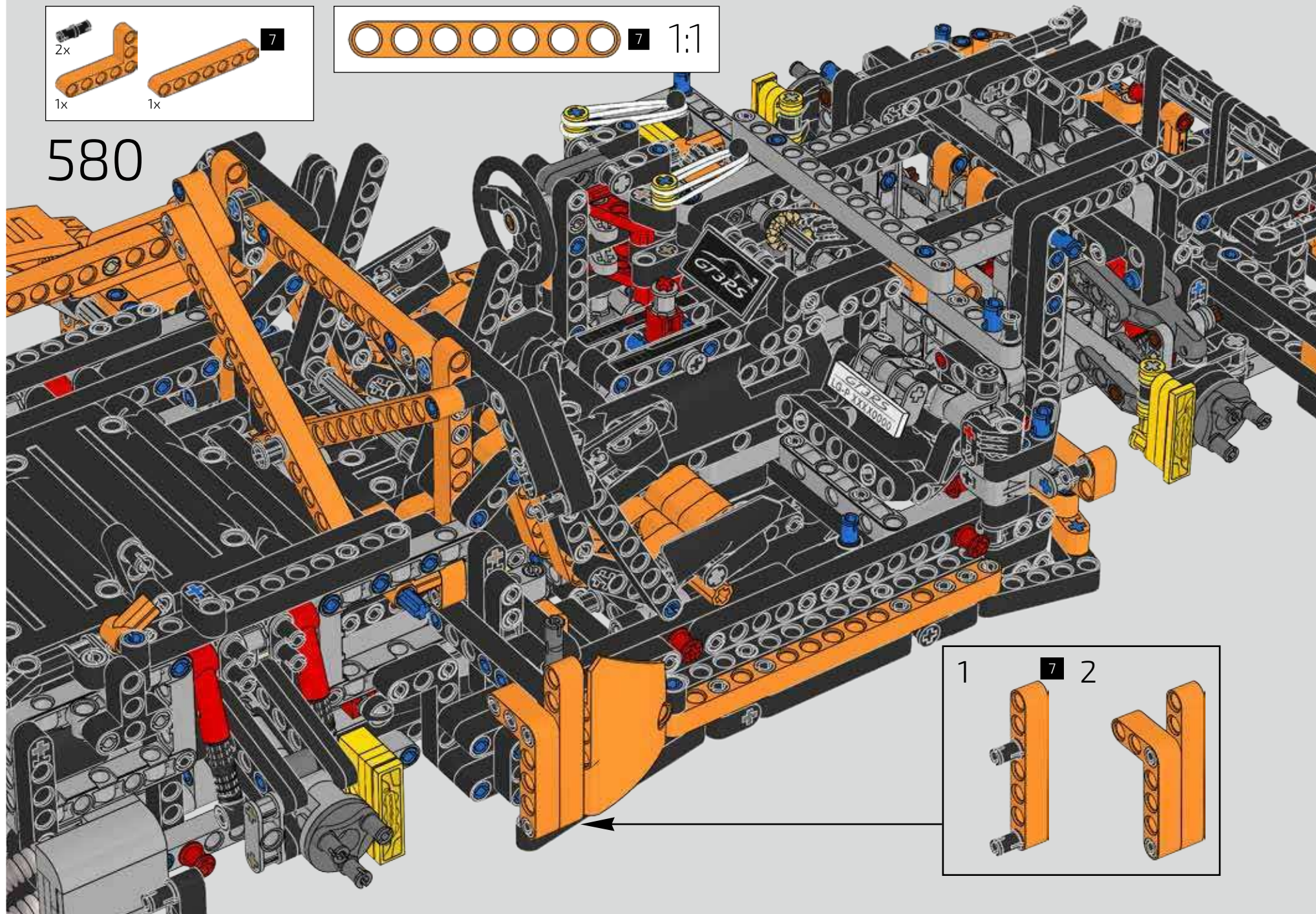

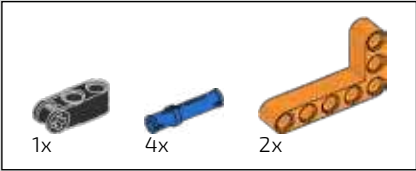

581

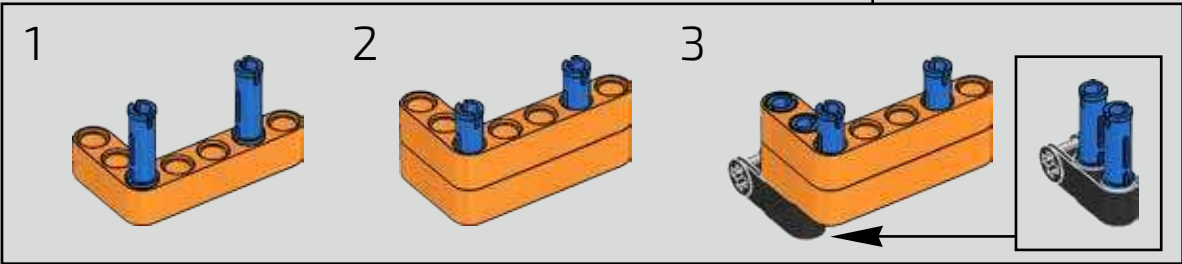
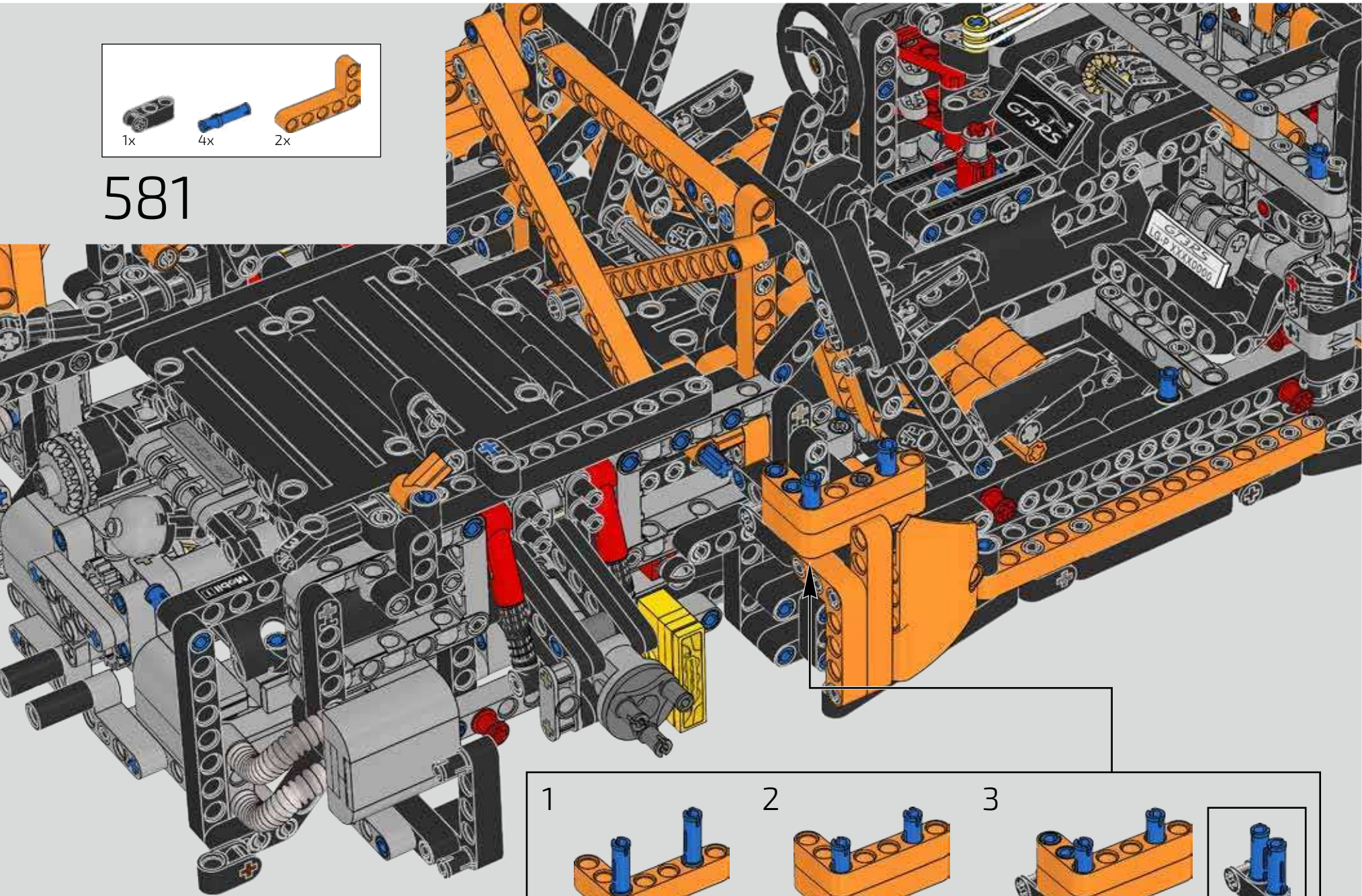

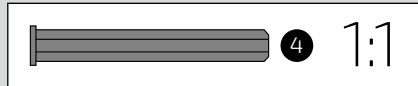
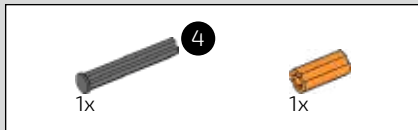

582

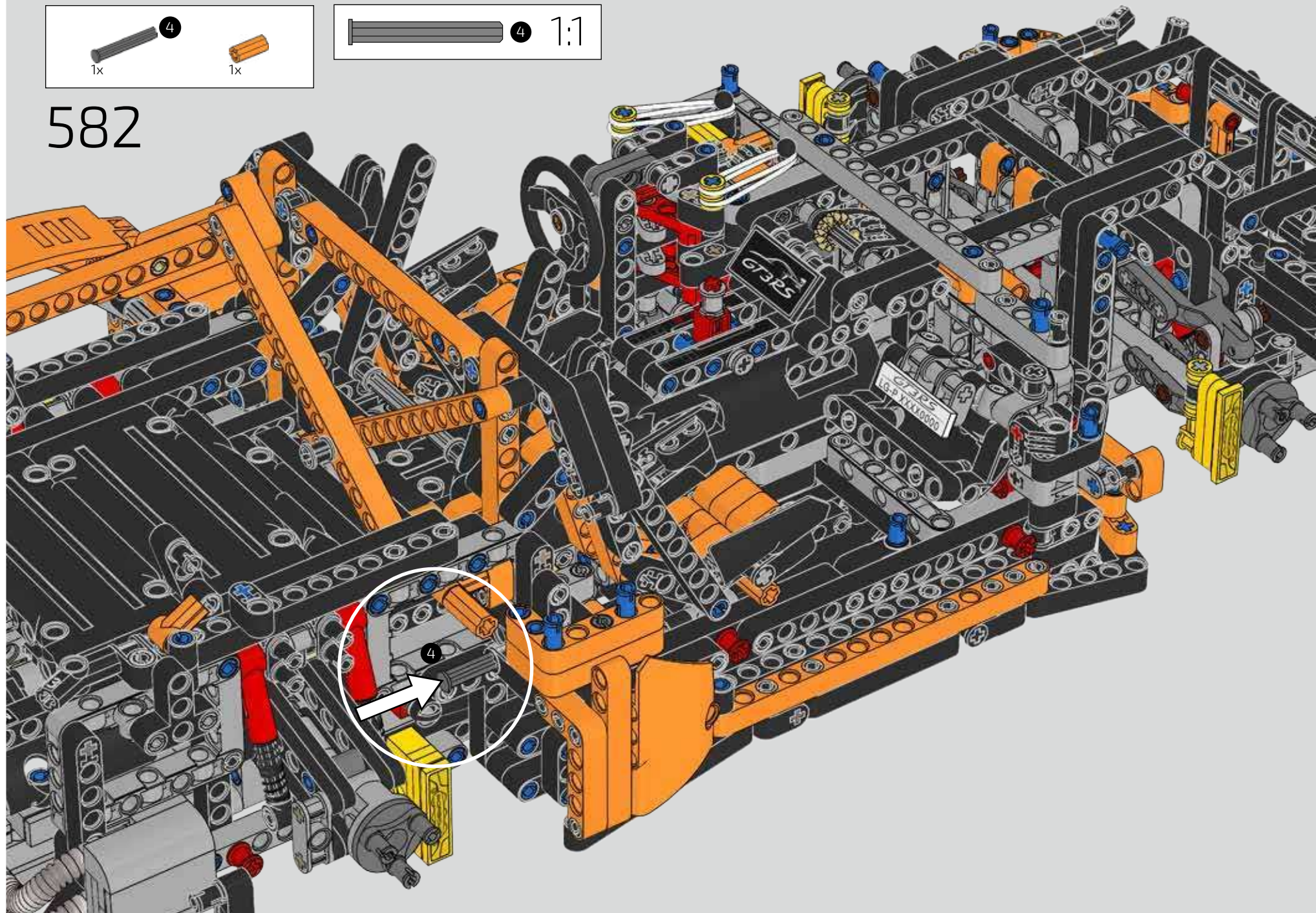

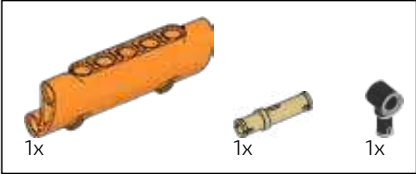

583

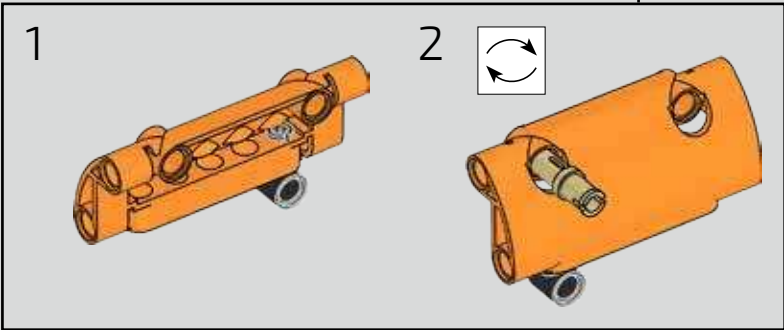
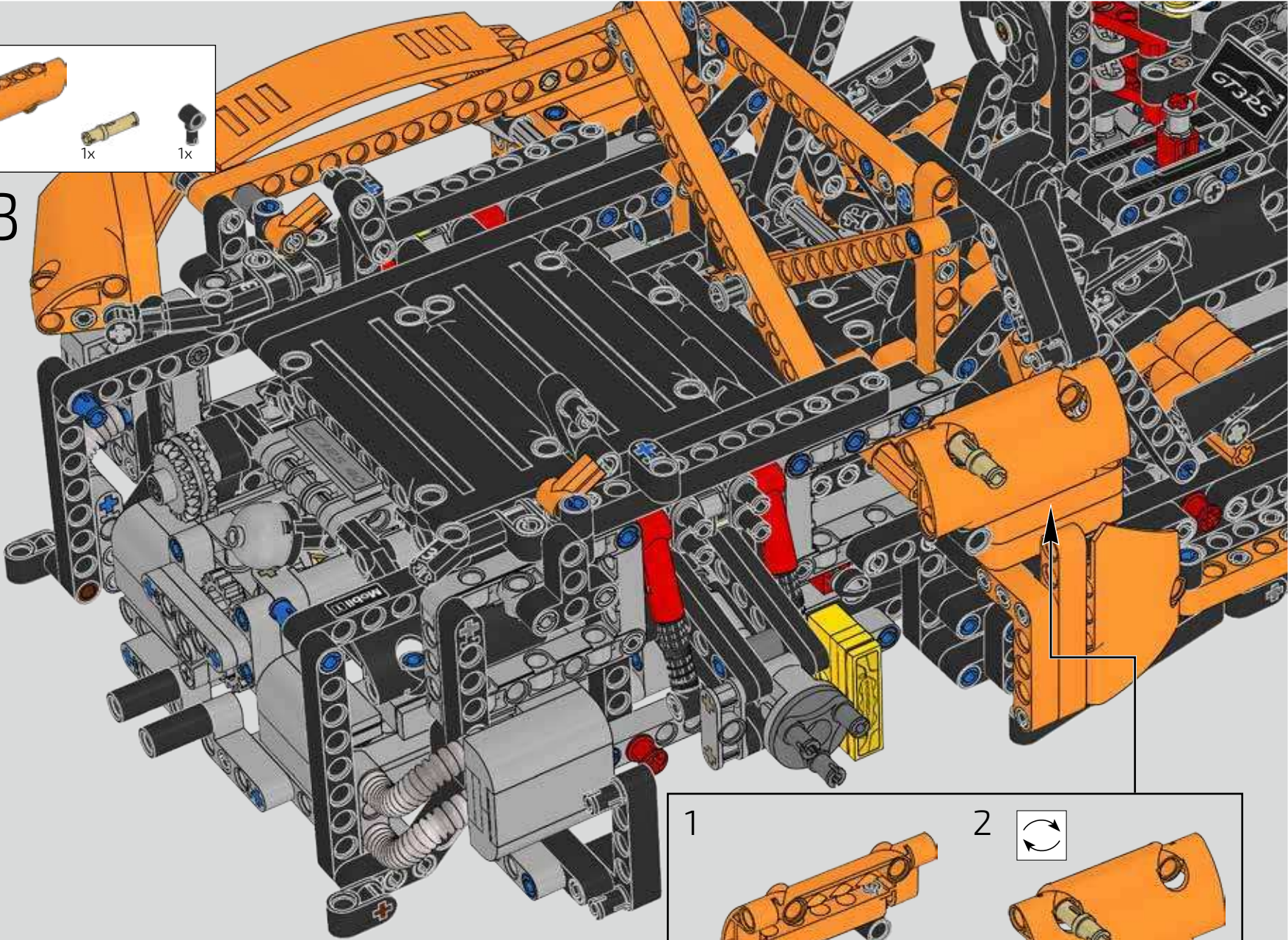

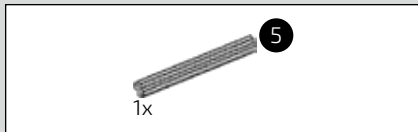

584

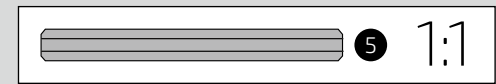
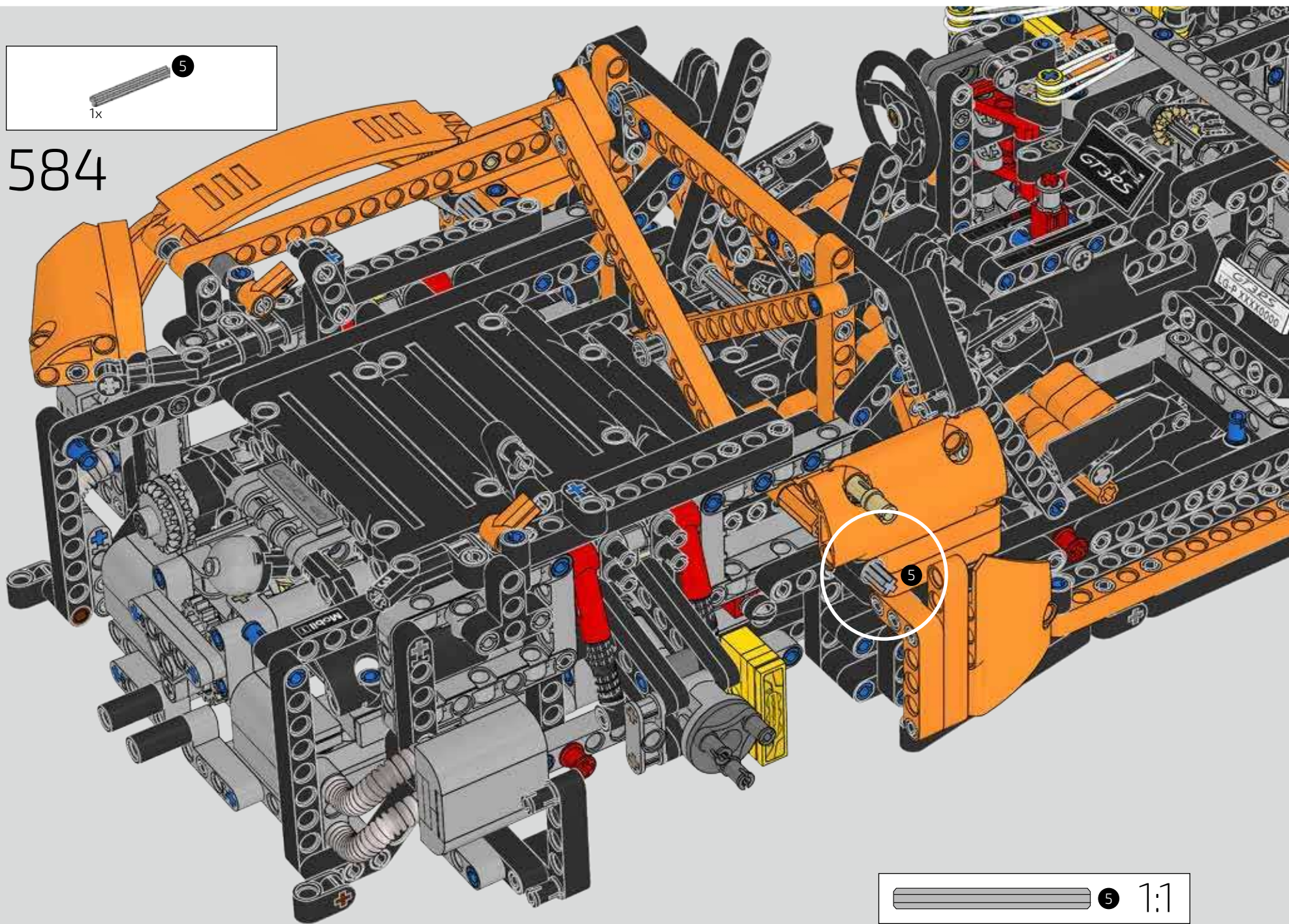

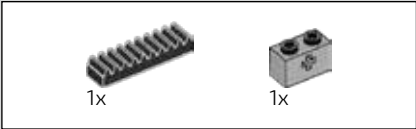

585

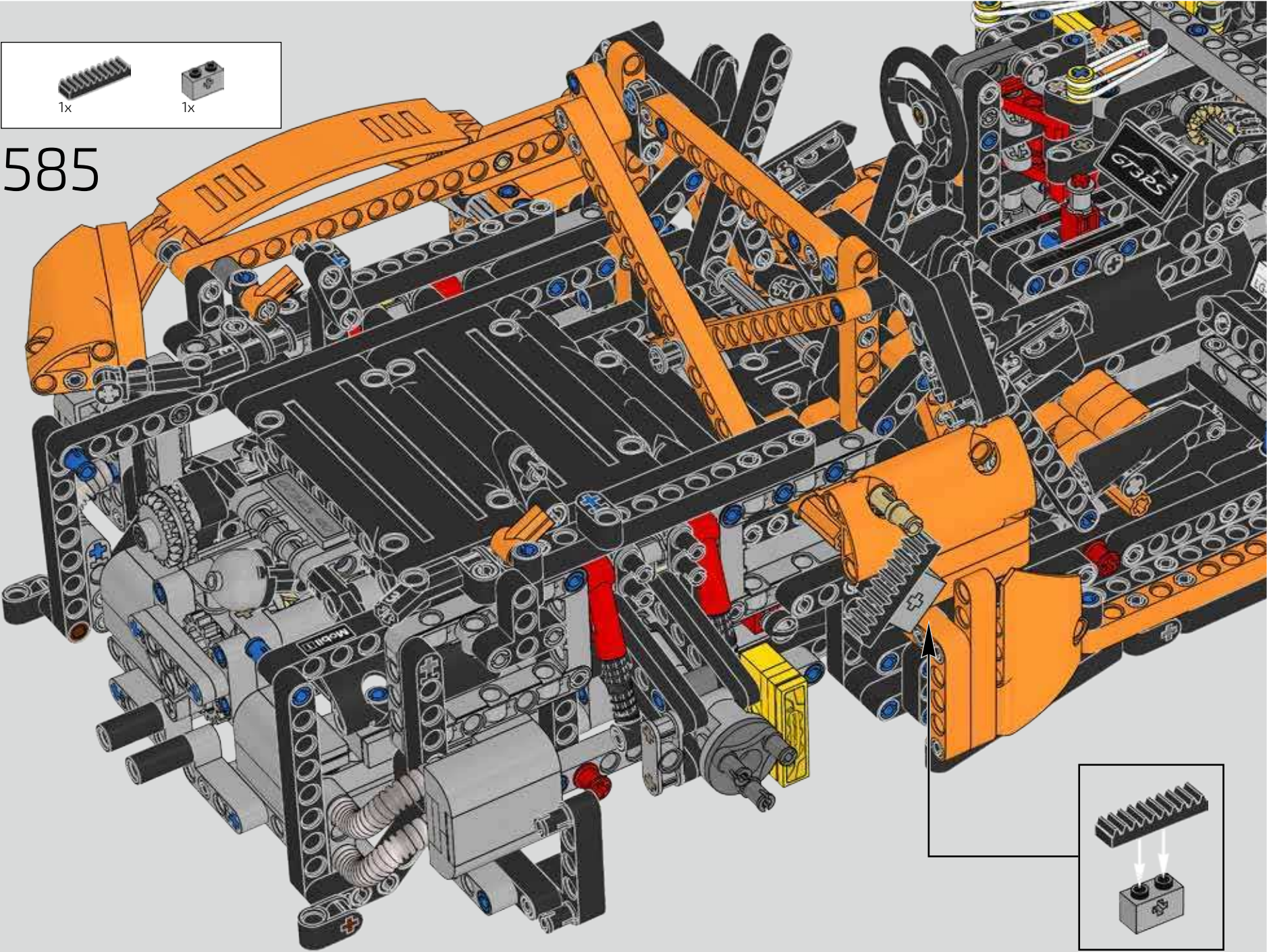

586

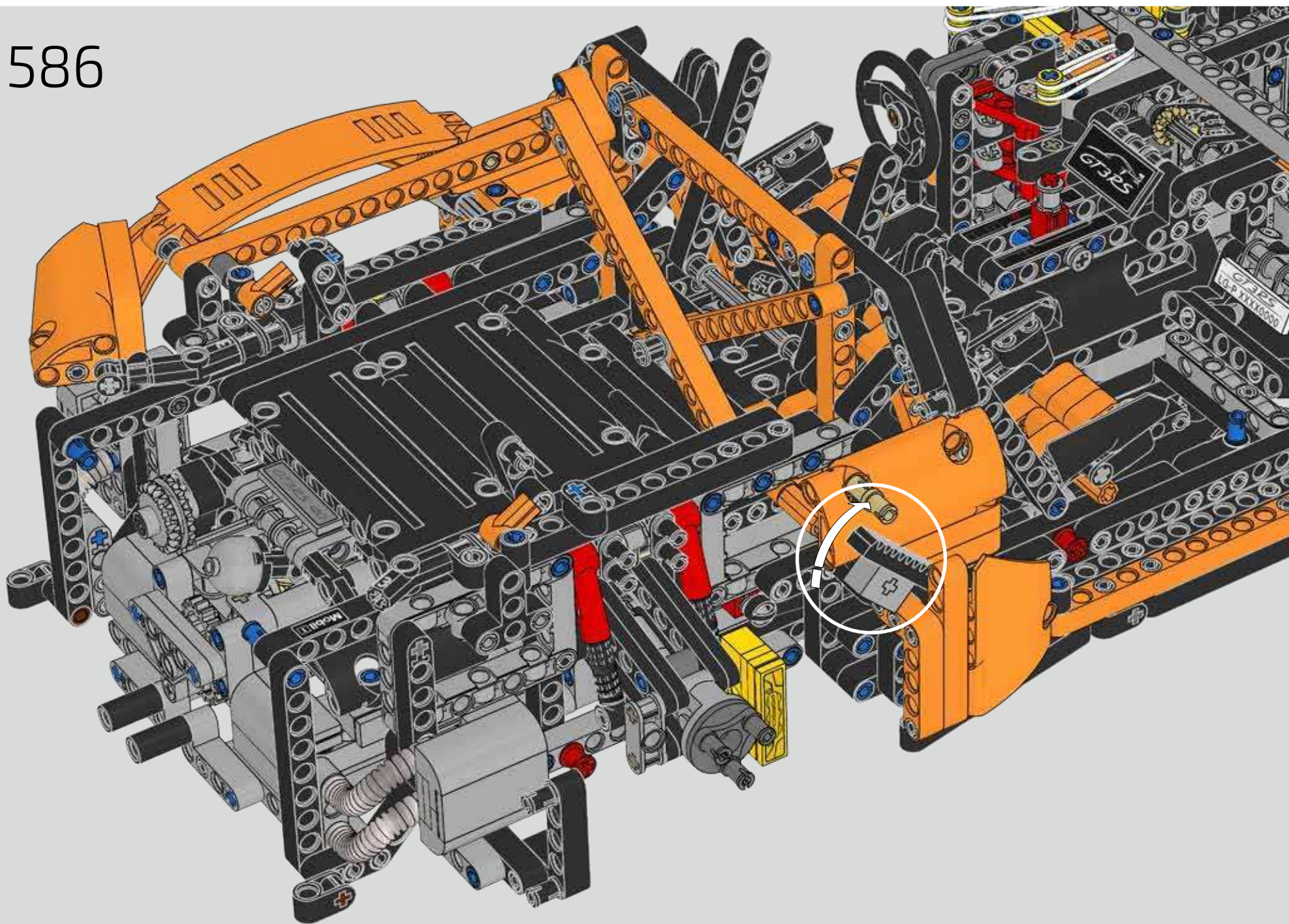

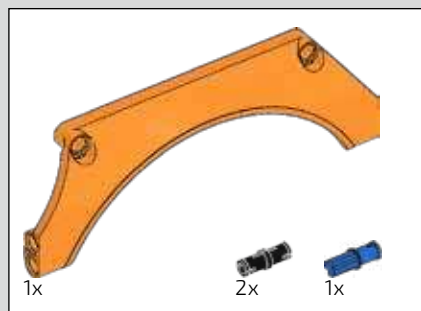

587

1

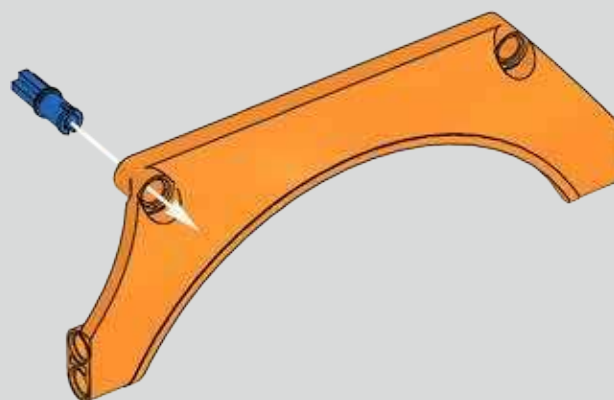

2

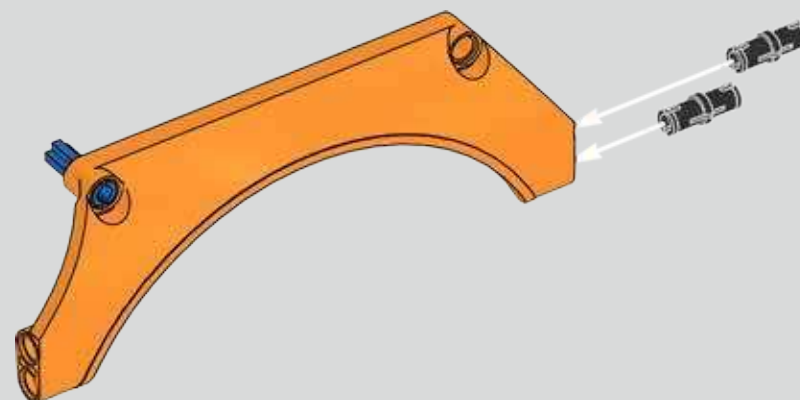

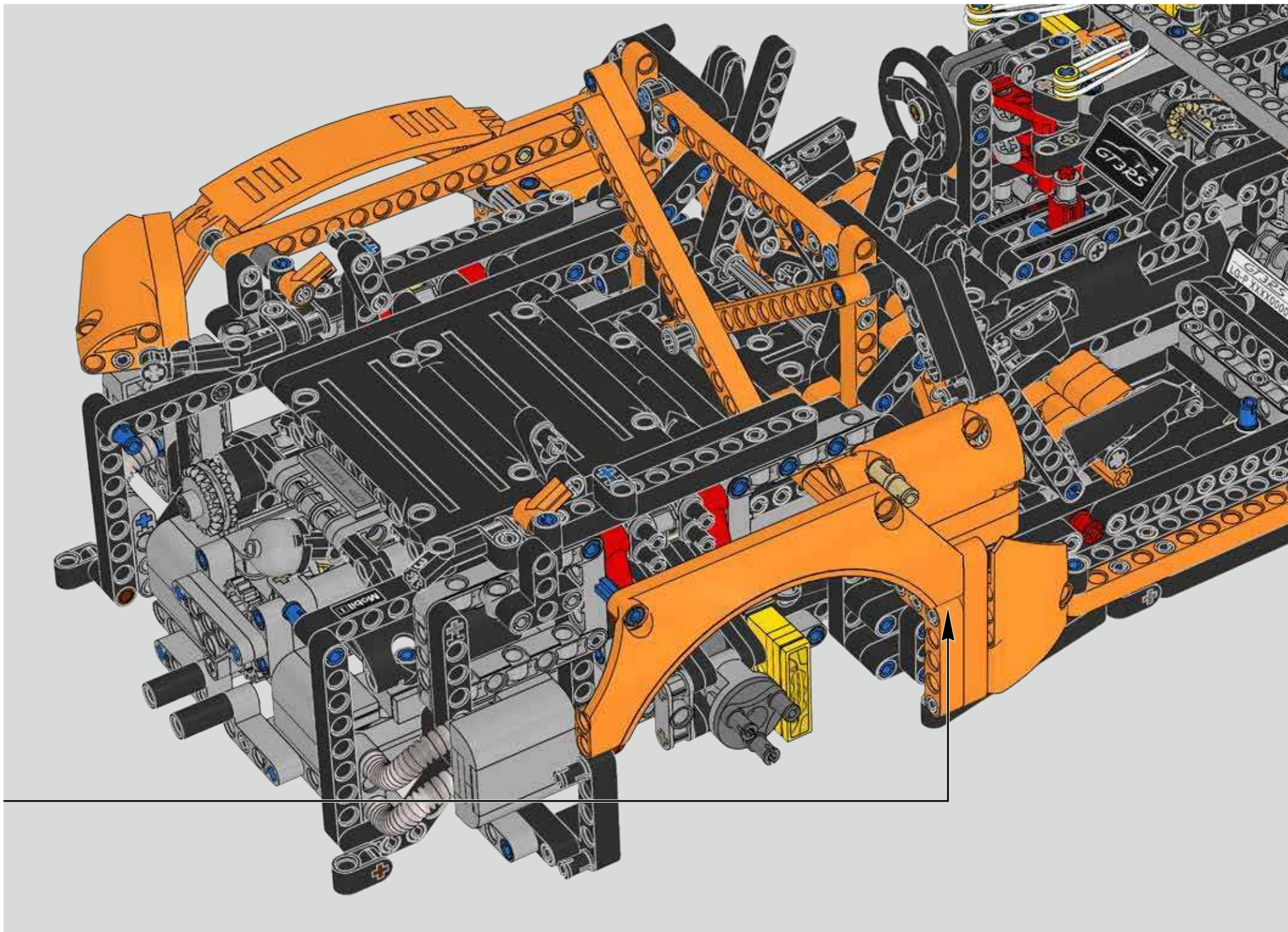

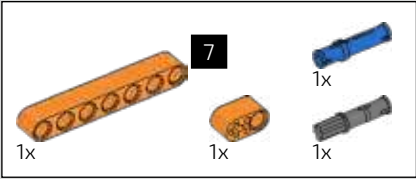

588

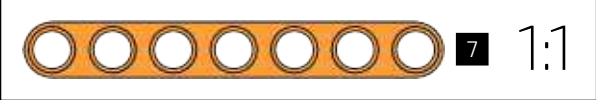
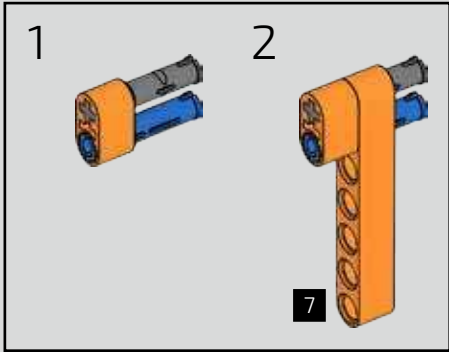
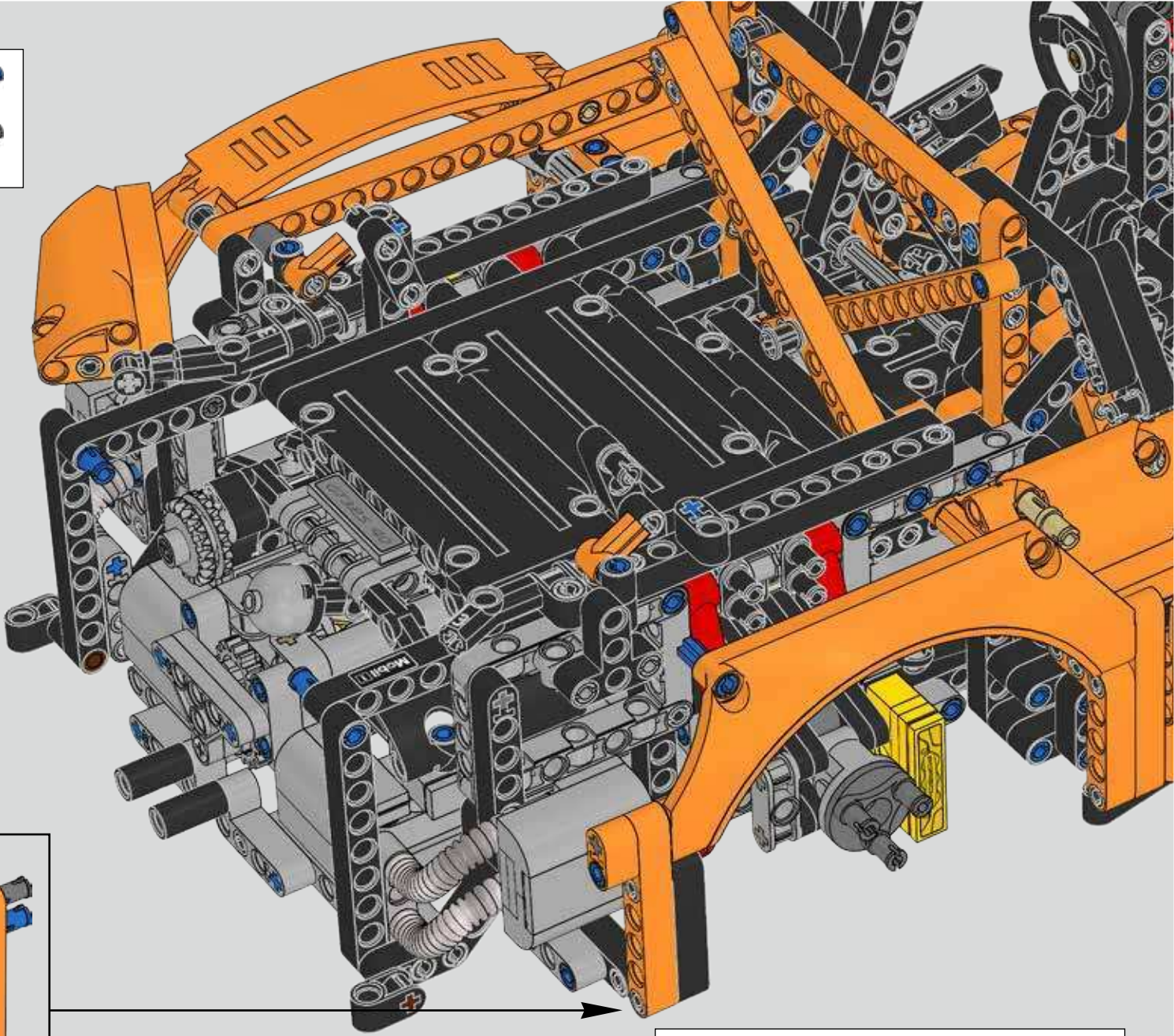

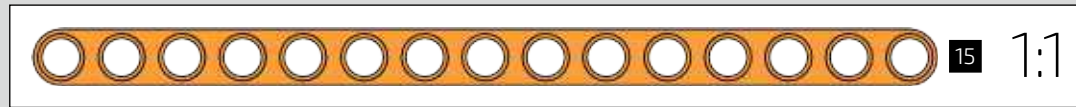
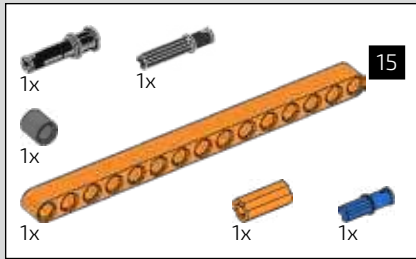

589

1

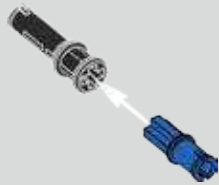

2

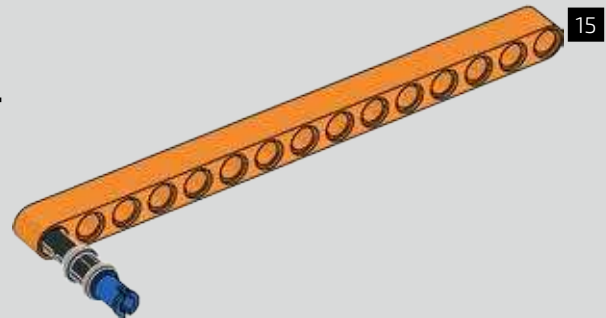

3

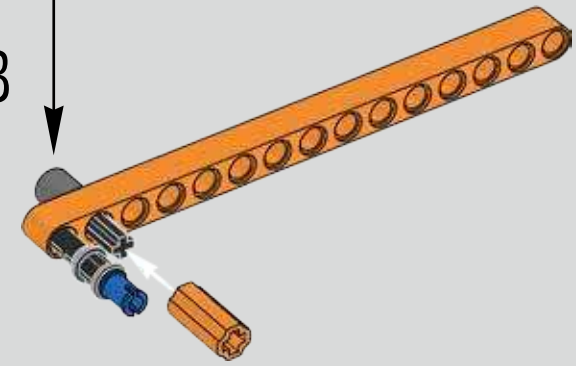
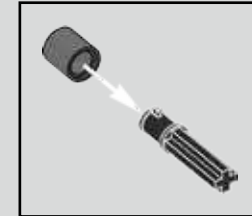

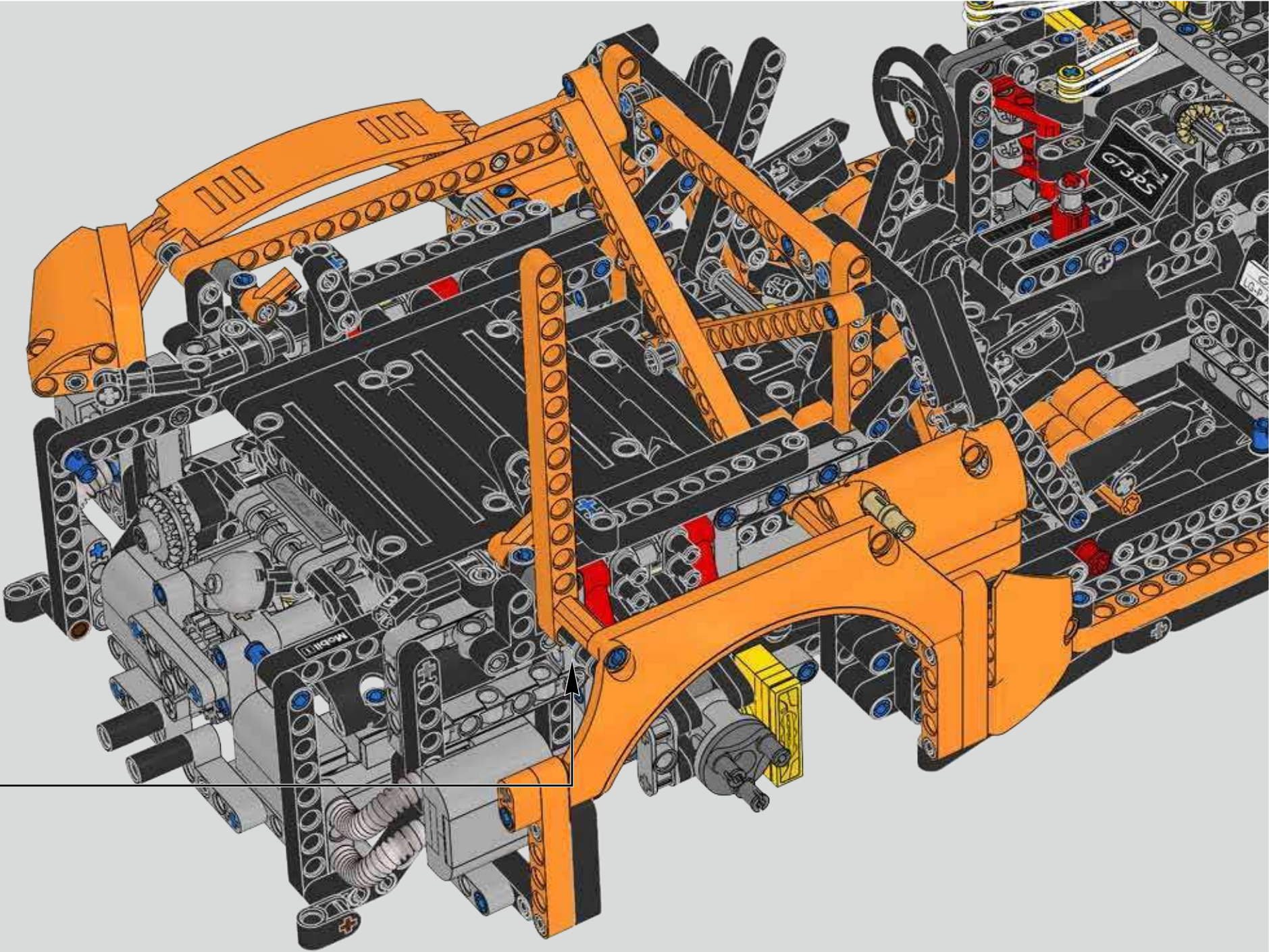

590

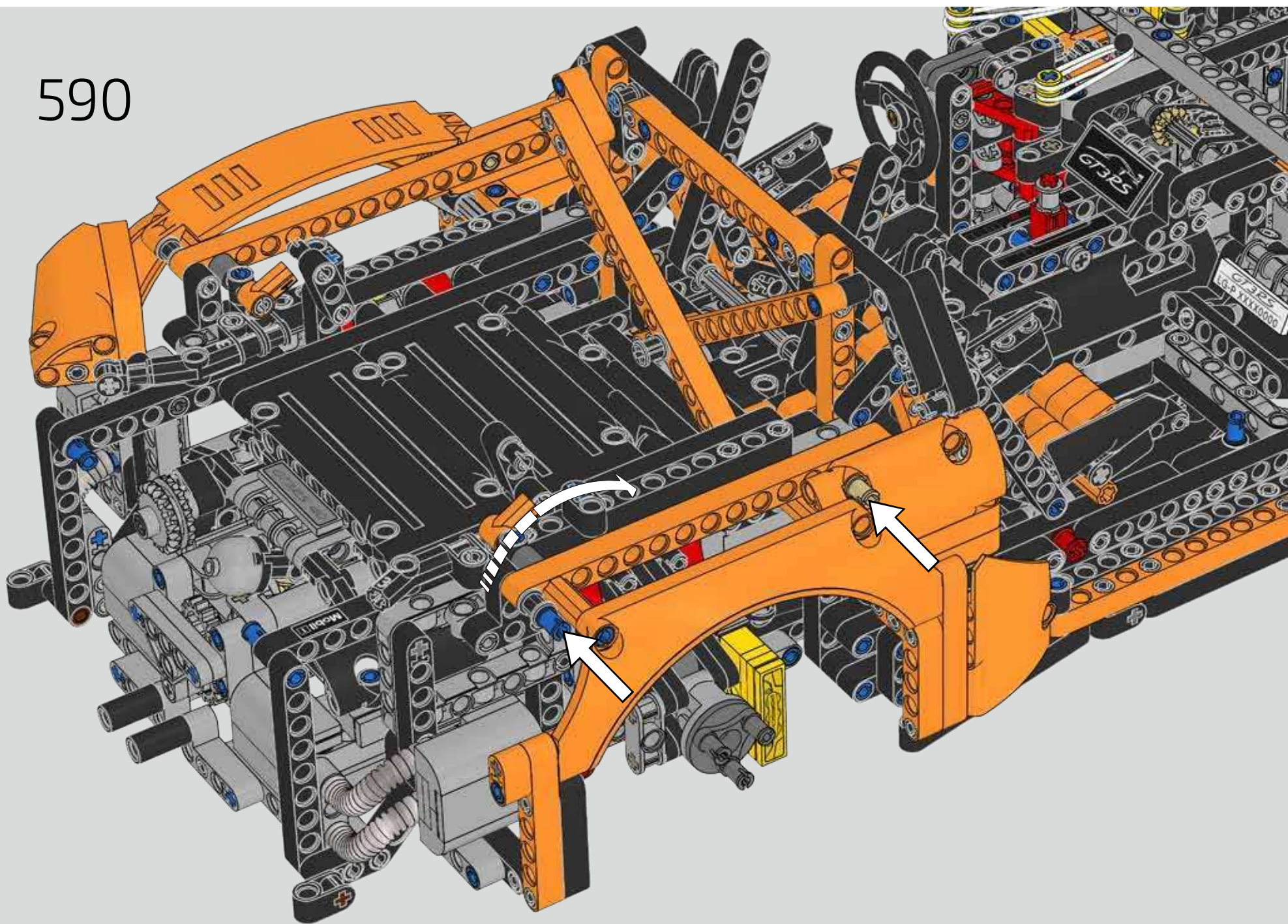

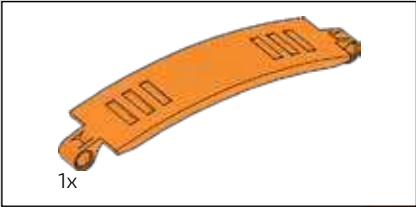

591

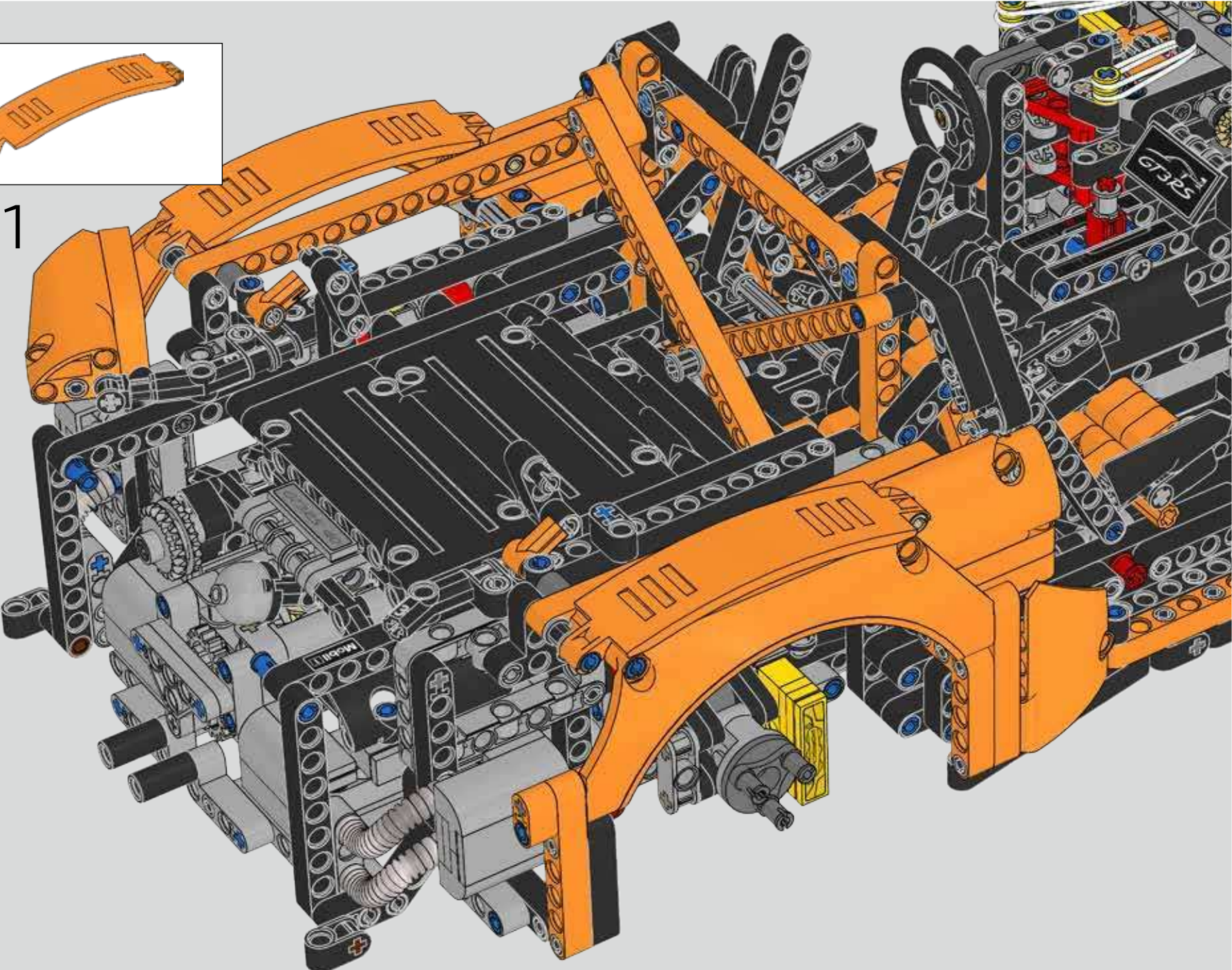

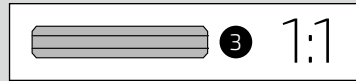
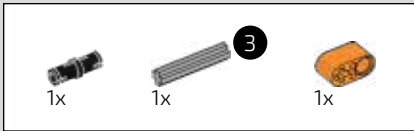

592

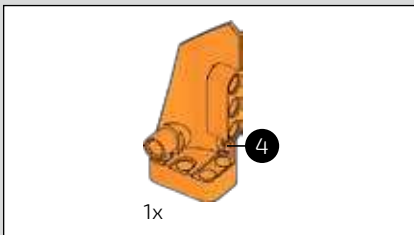
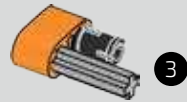

593

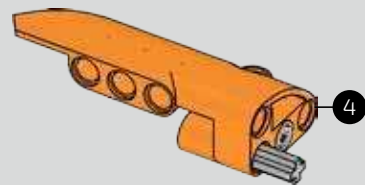

594

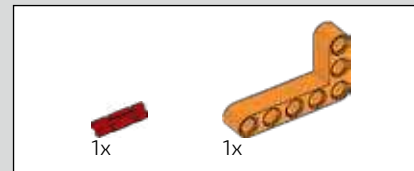
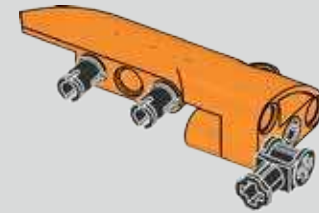

595

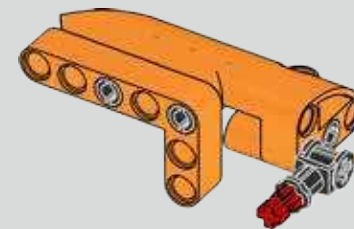

596

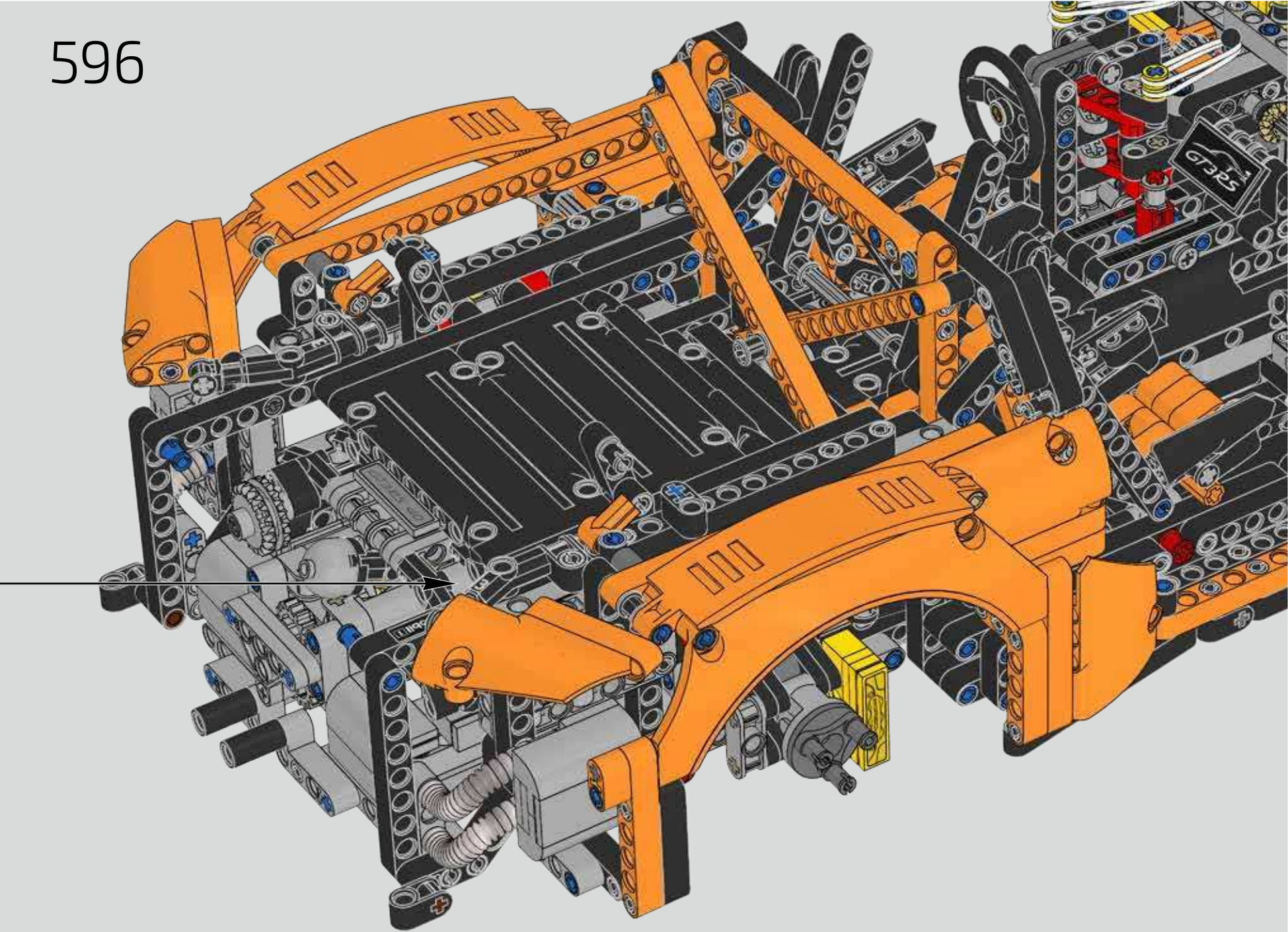

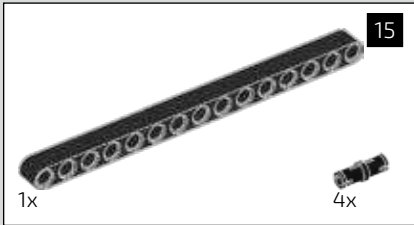
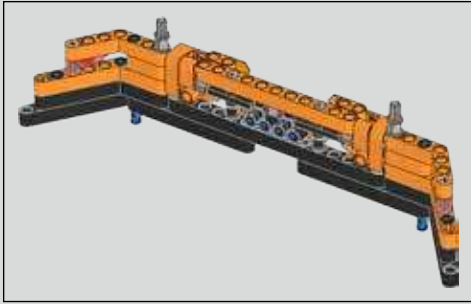

597

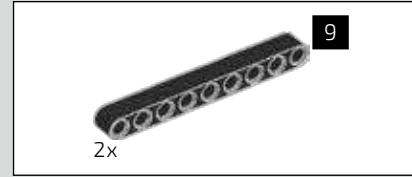

598

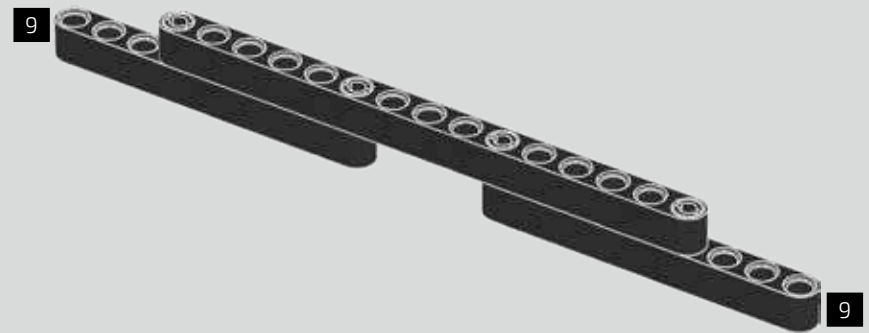

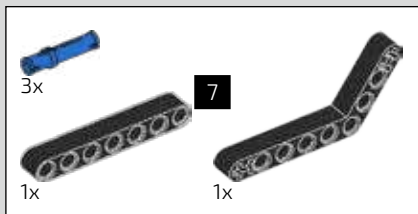

599

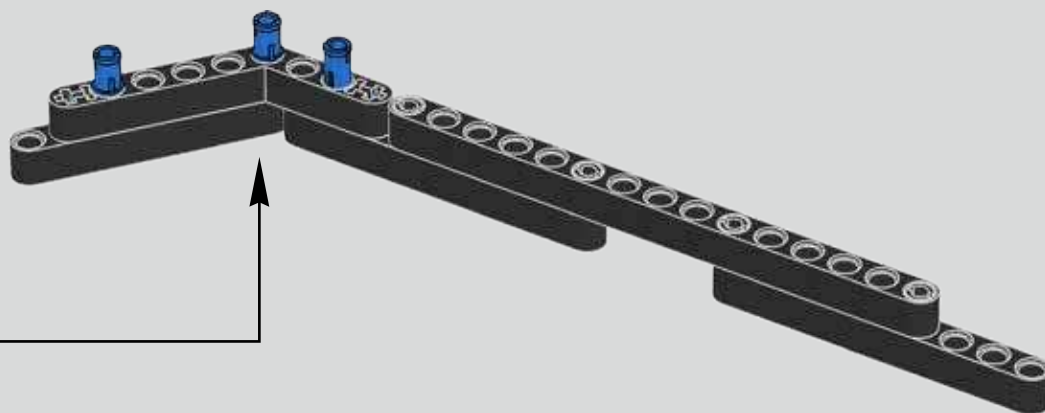
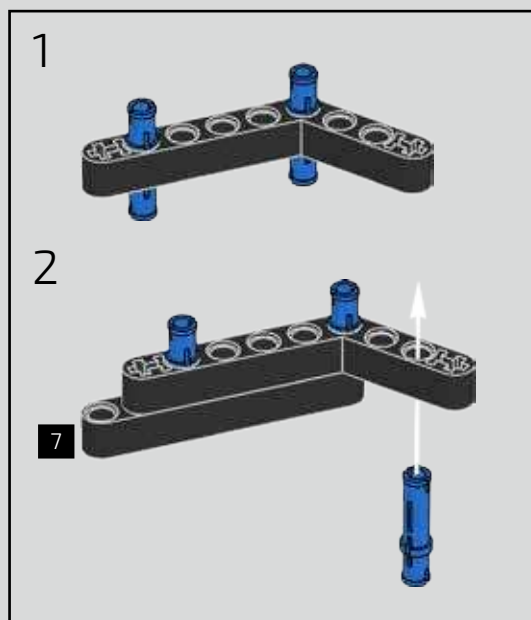

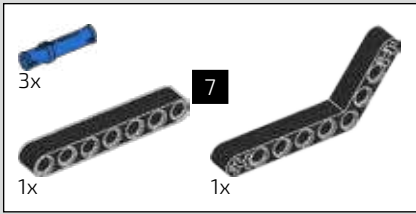

600

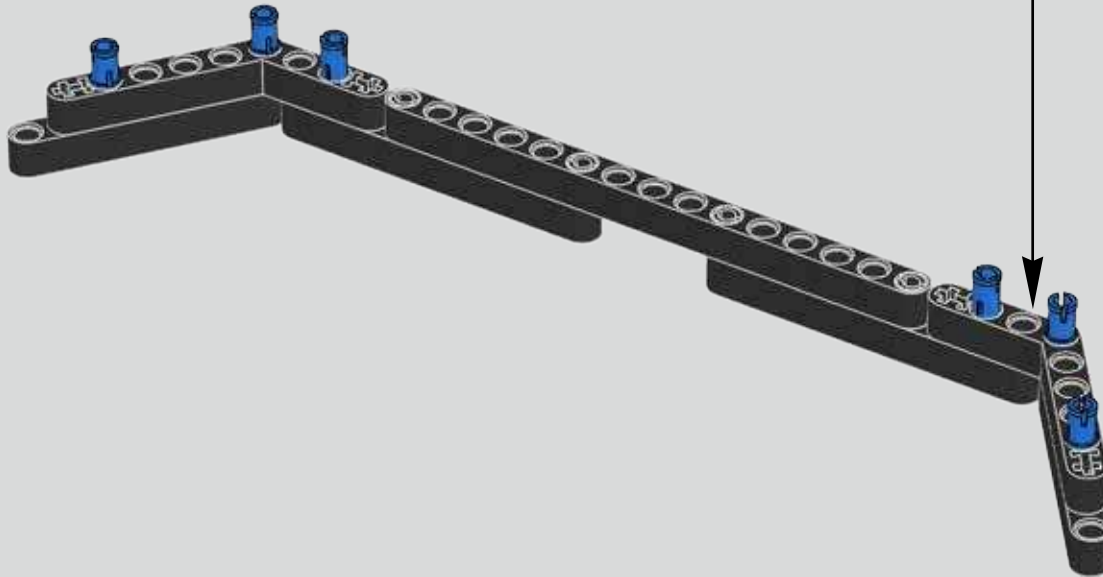
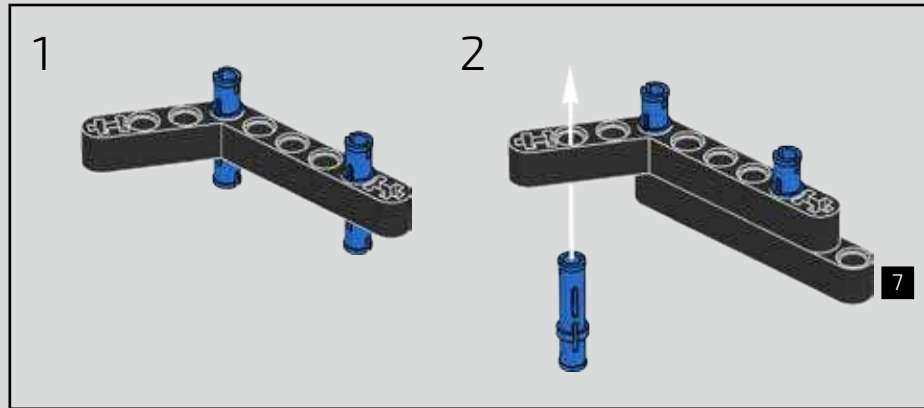

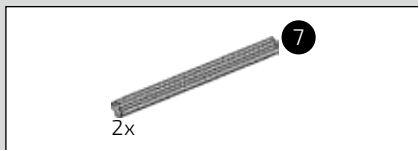

601

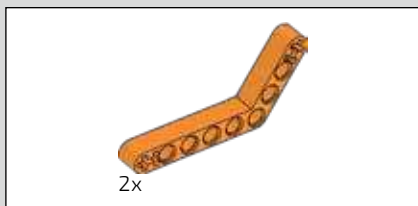
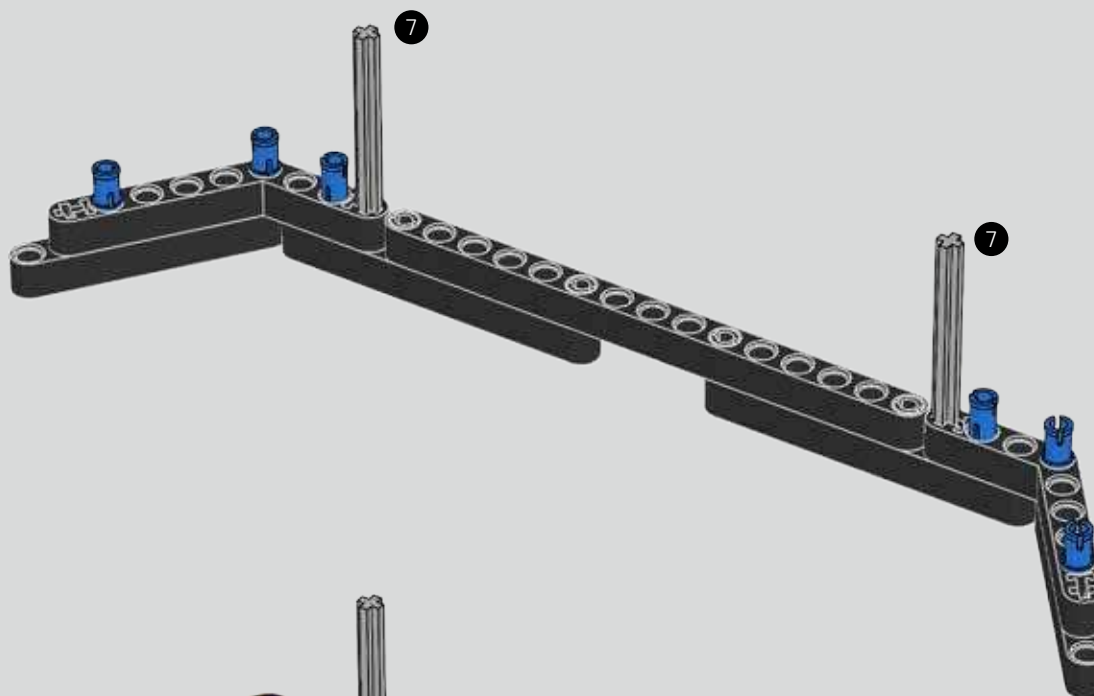

602

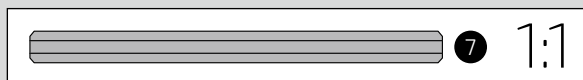
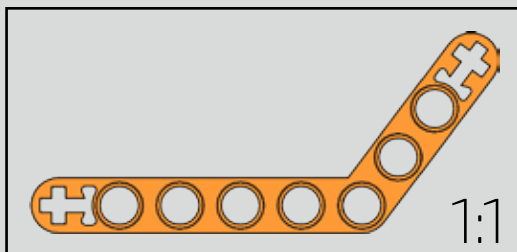
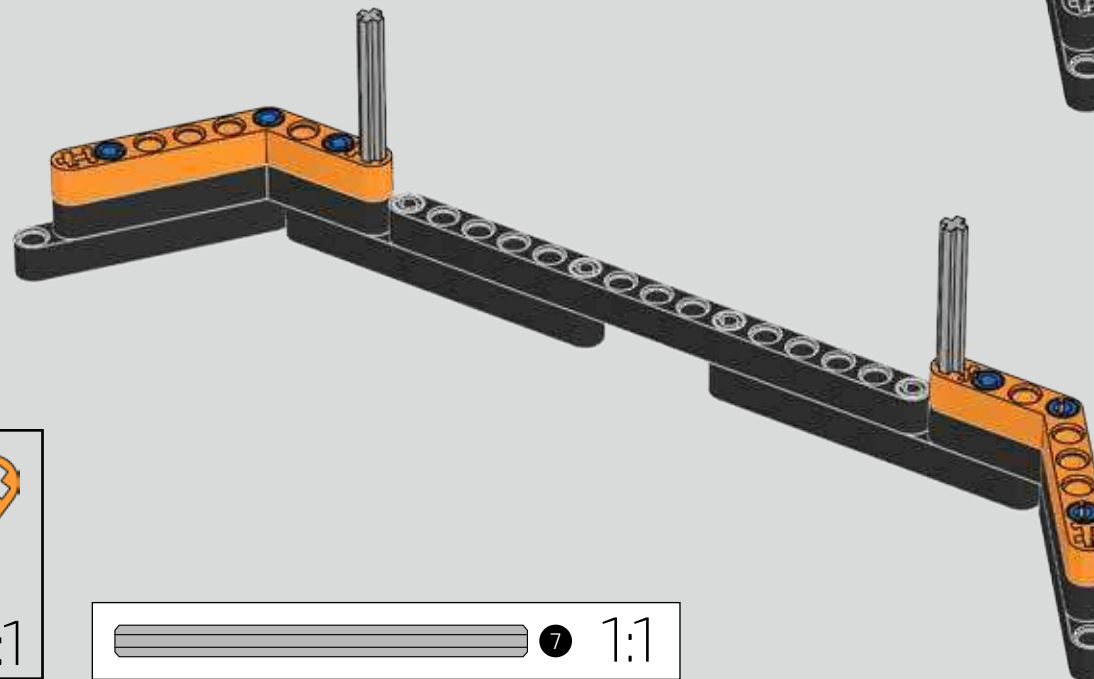



603

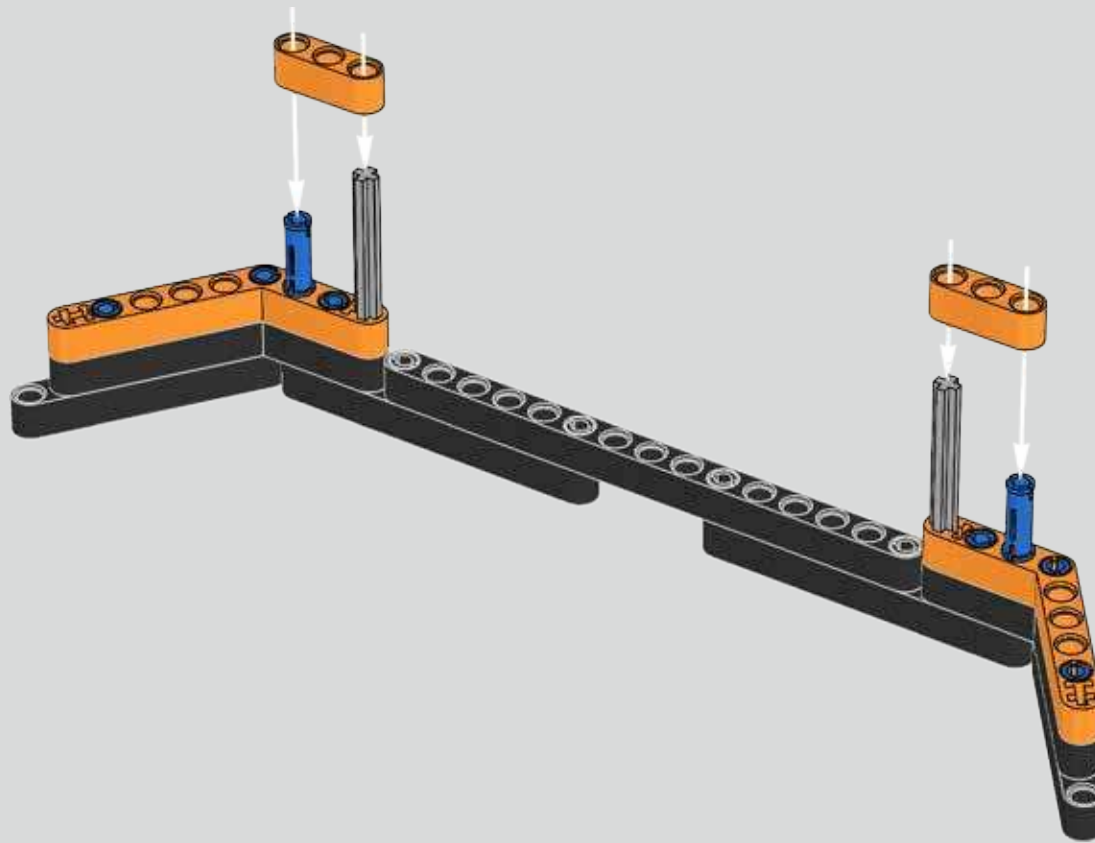

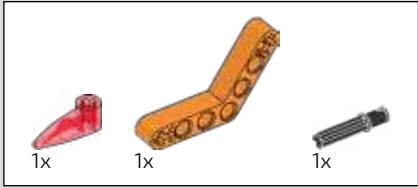

604

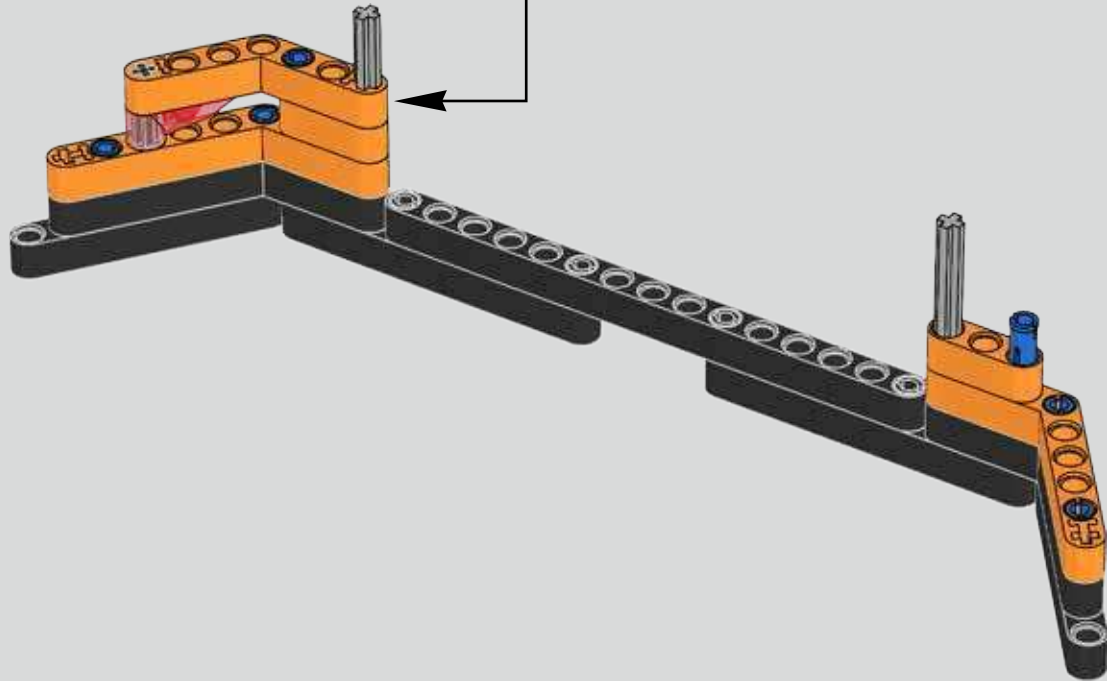
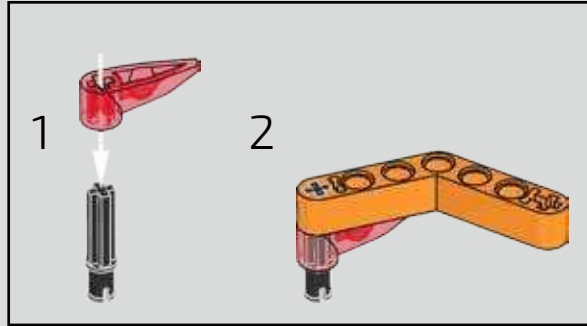

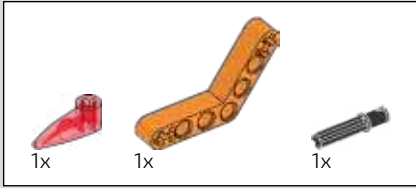

605

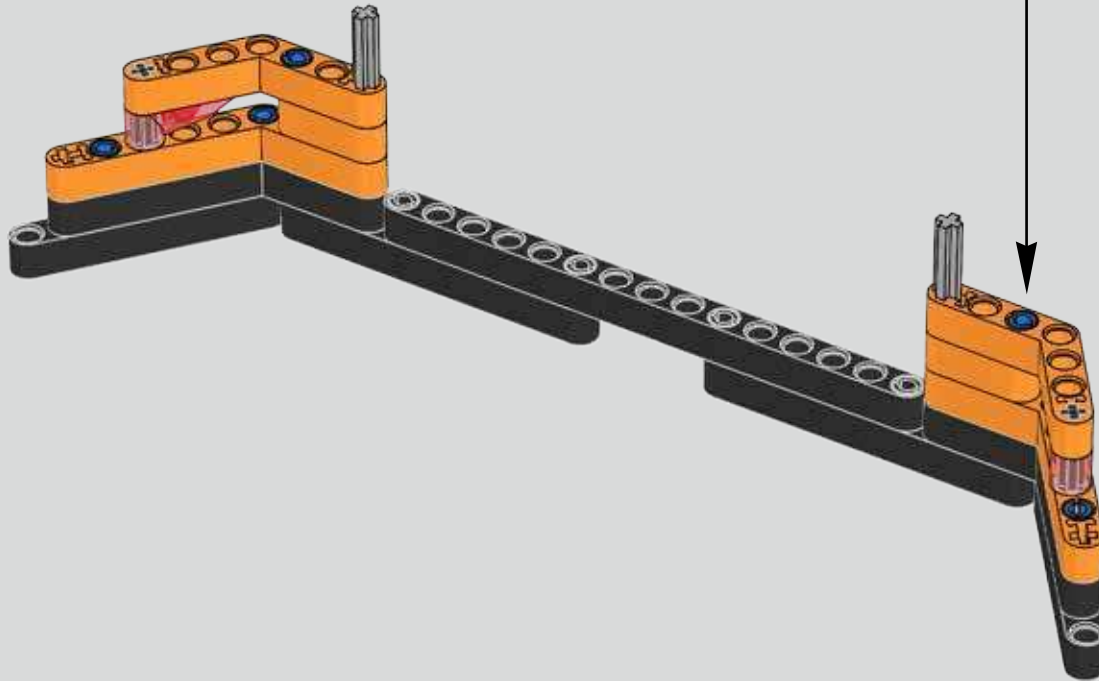
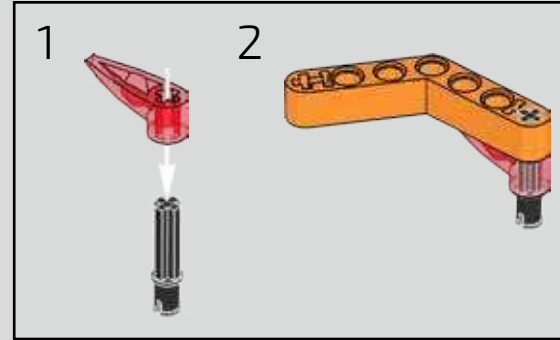

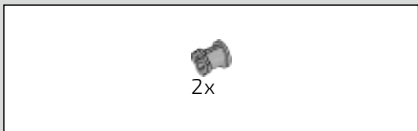

606

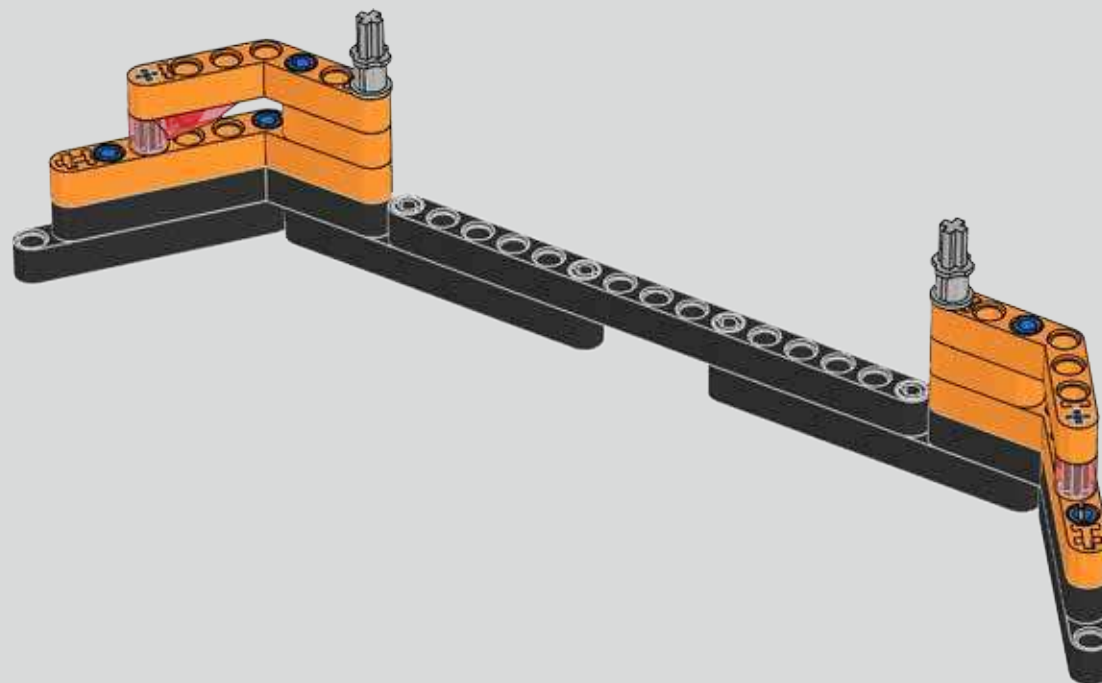

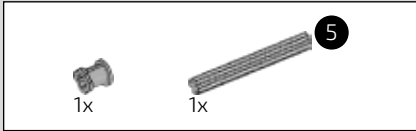
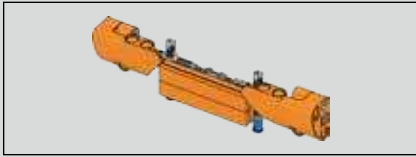

607

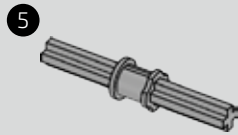

608

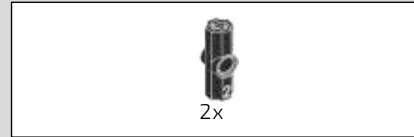
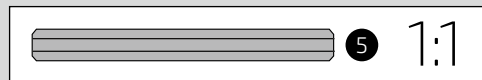

609

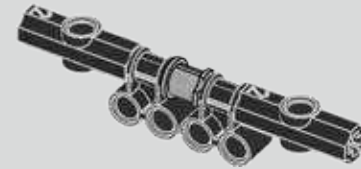

610

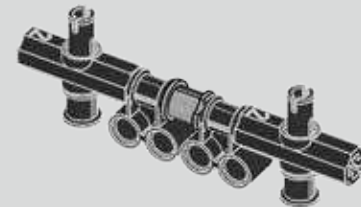

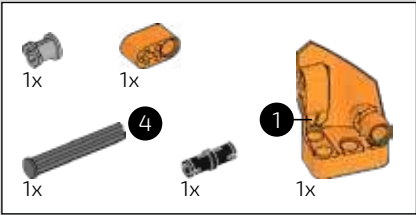

611

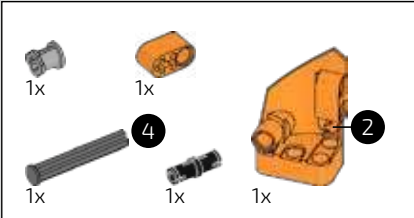
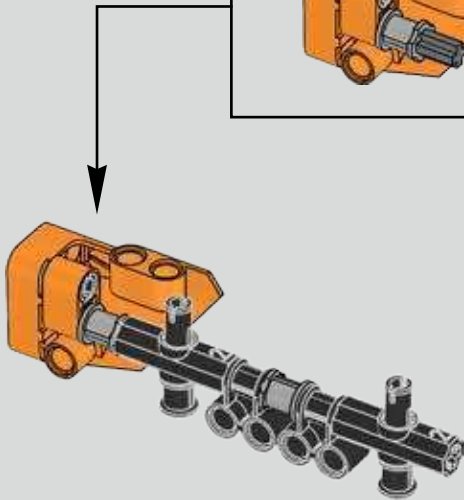
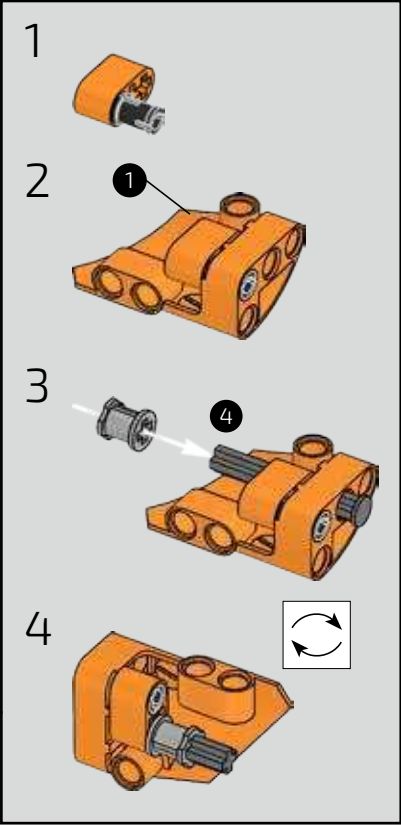

612

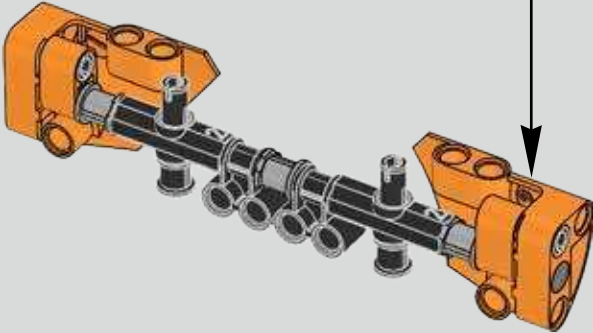
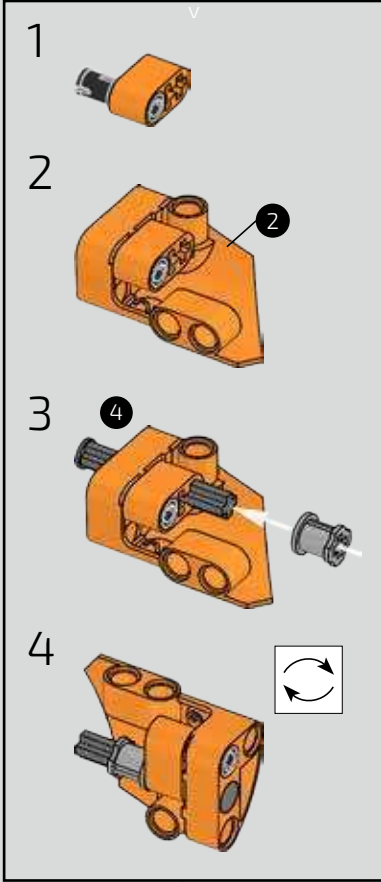



613

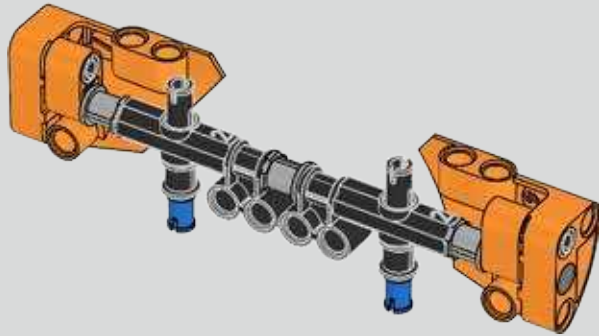

614

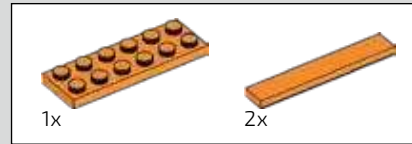
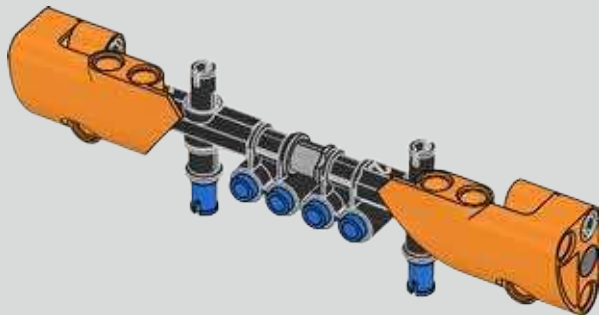
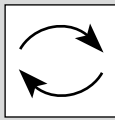

615

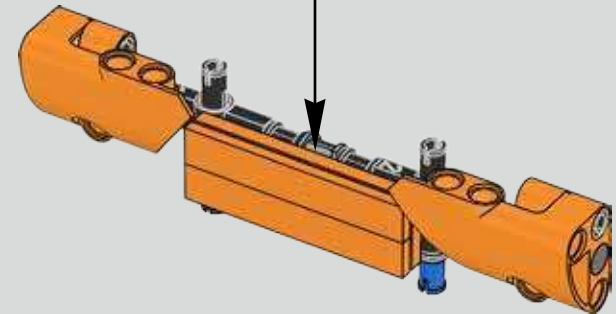
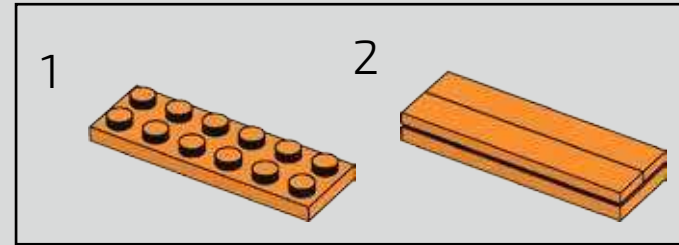

616

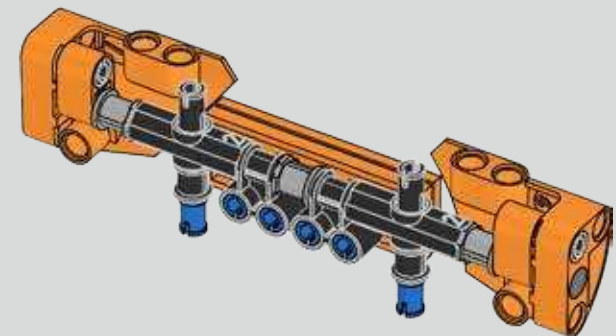
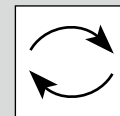

617

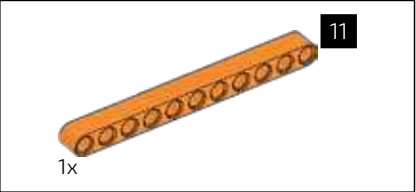
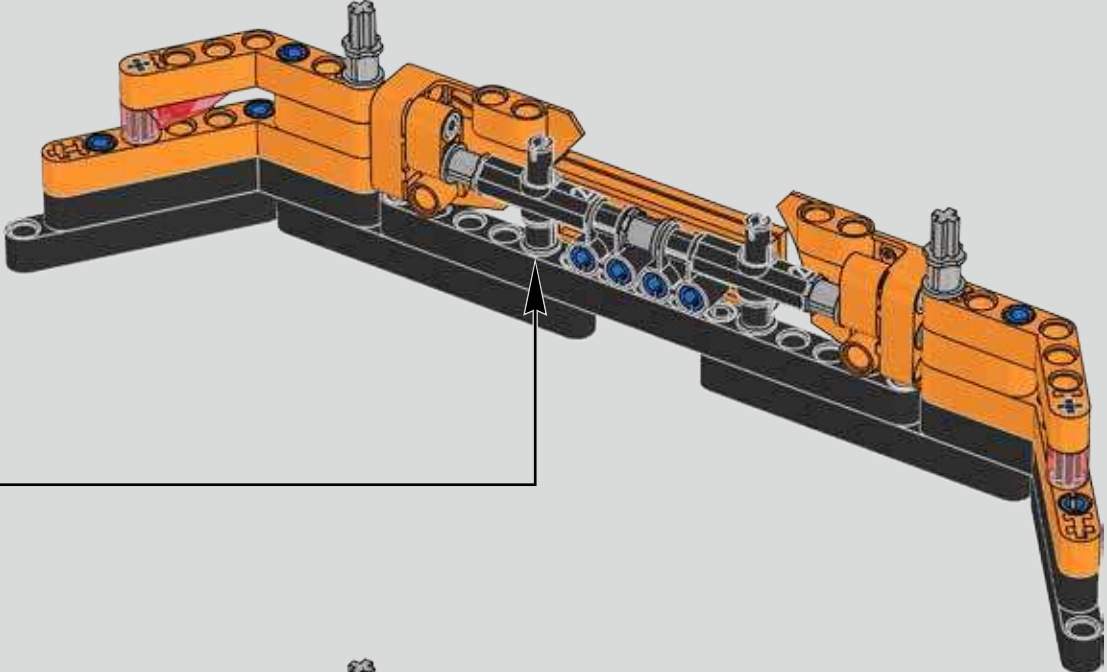

618

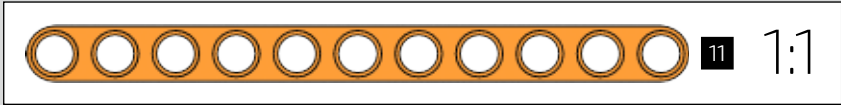
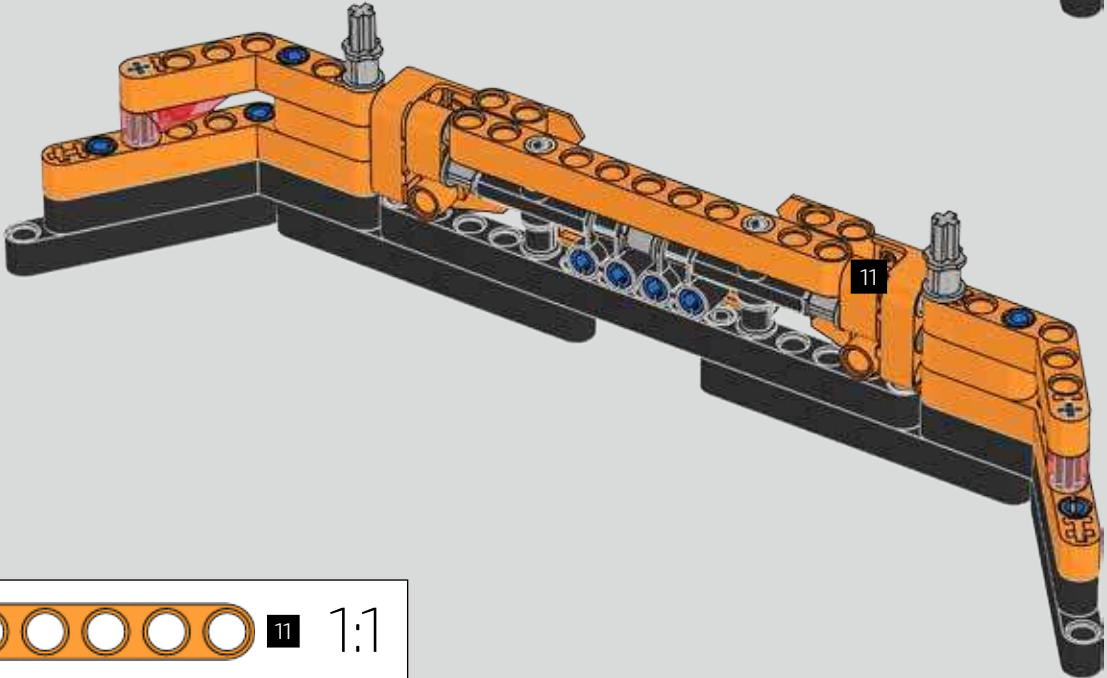



619

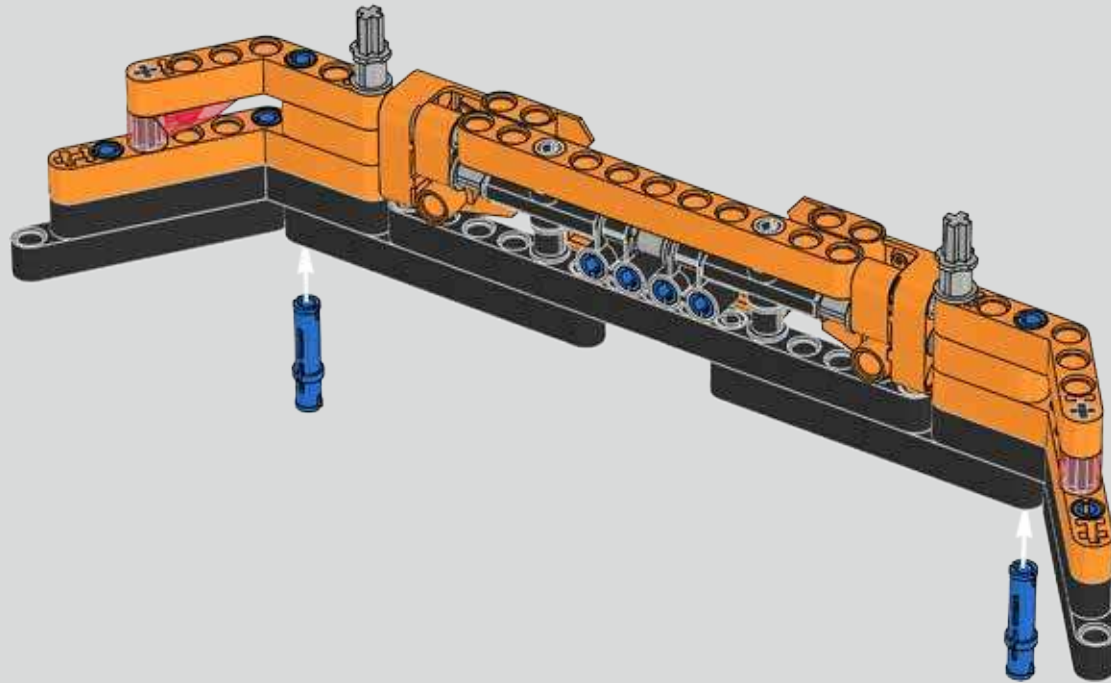

620

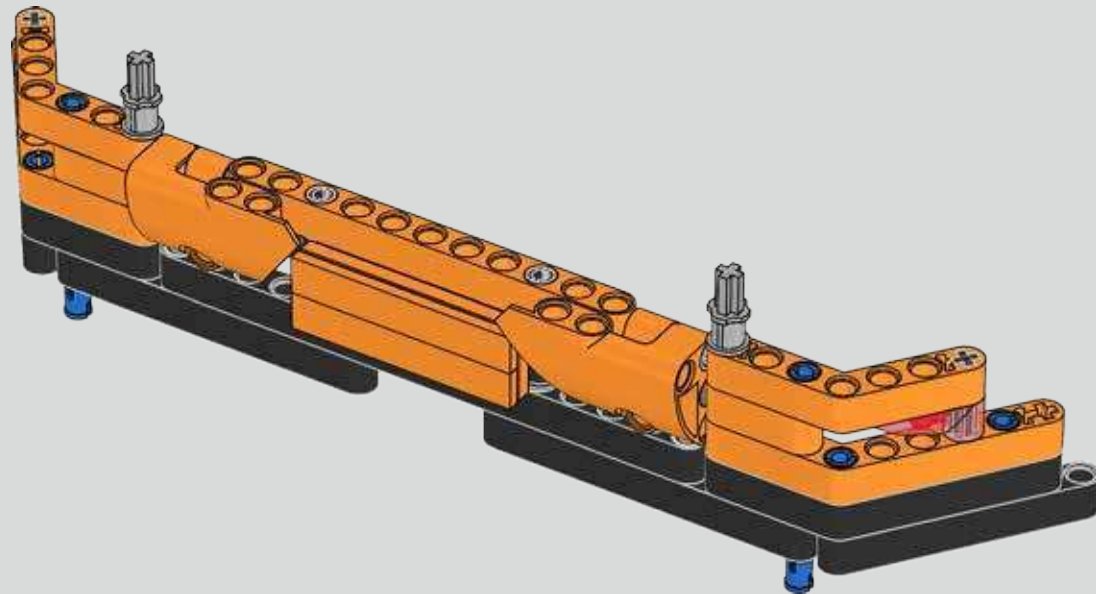
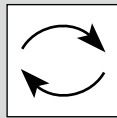

621

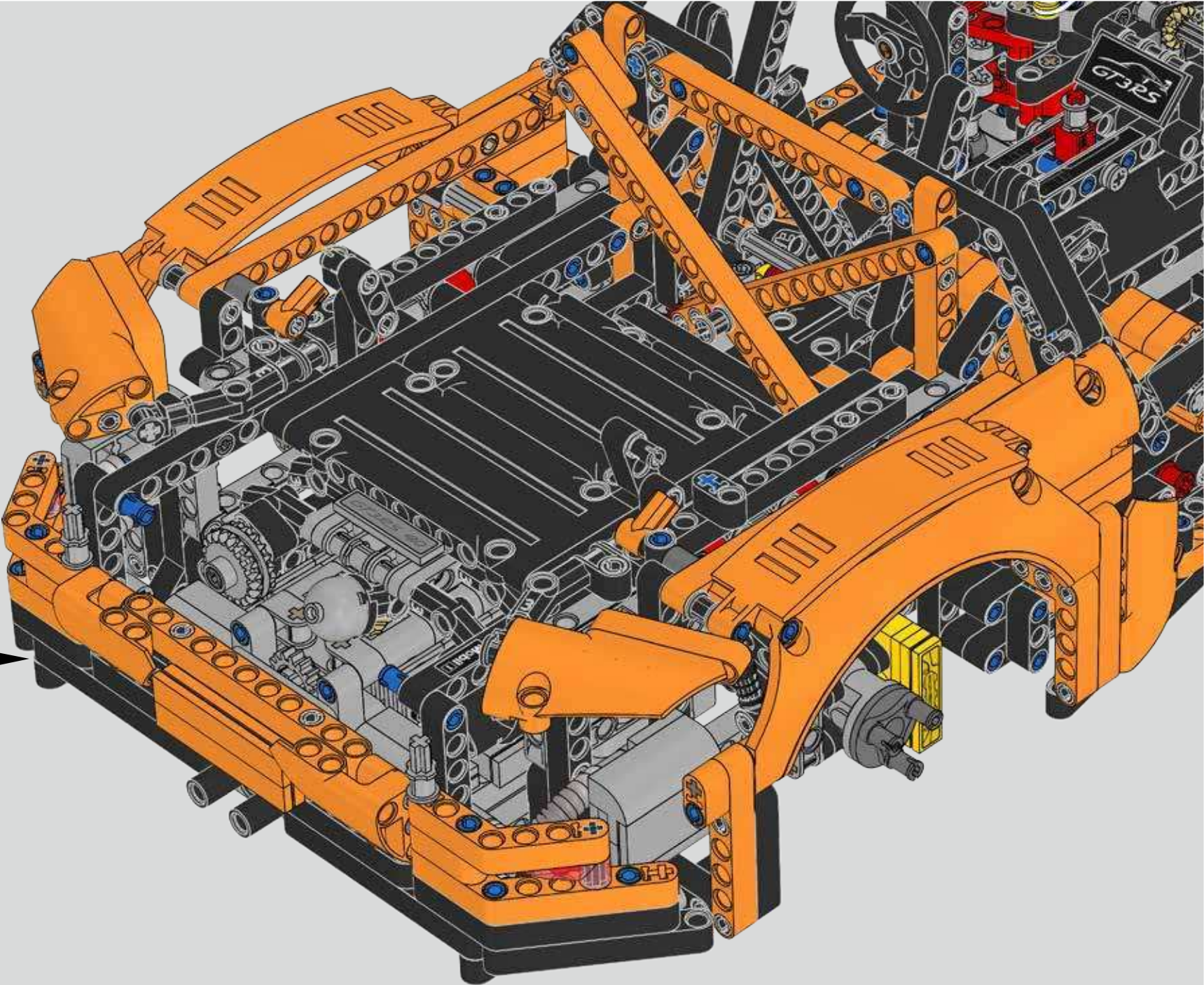

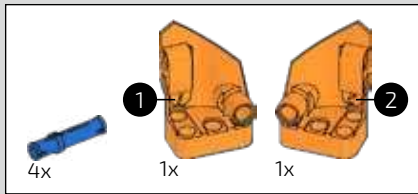

622

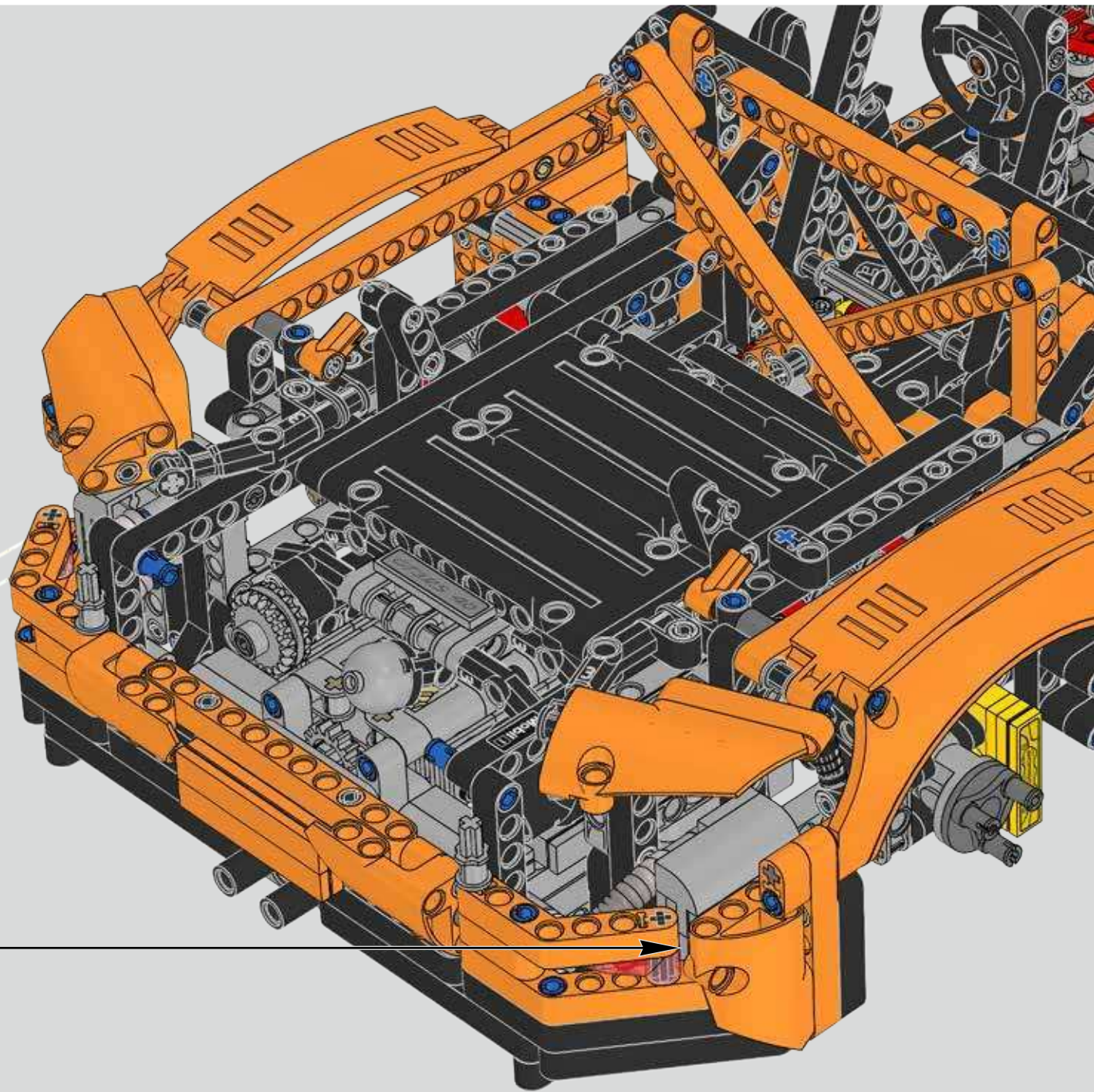
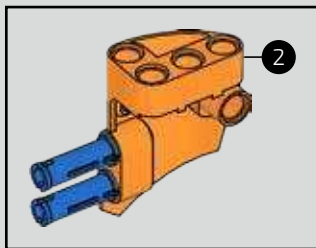
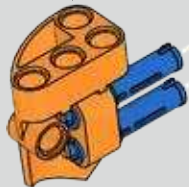
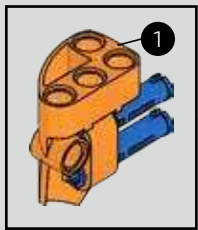

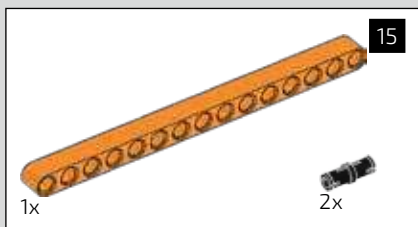
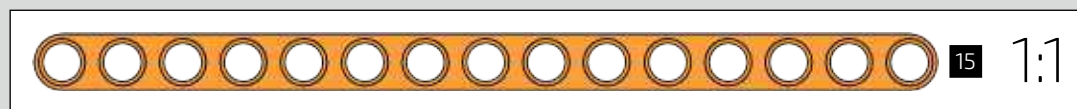
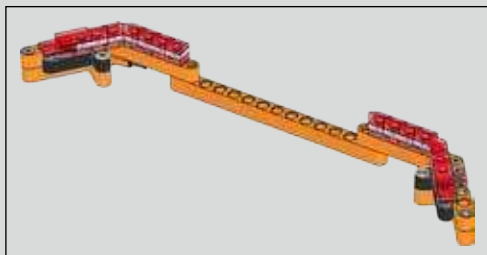

623

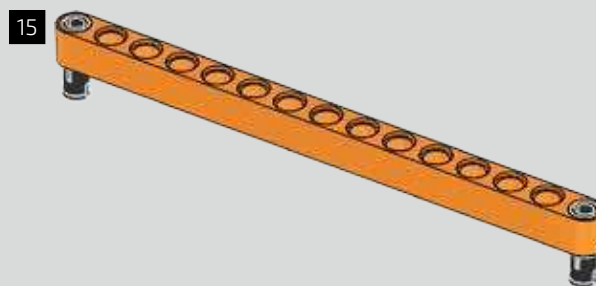

624

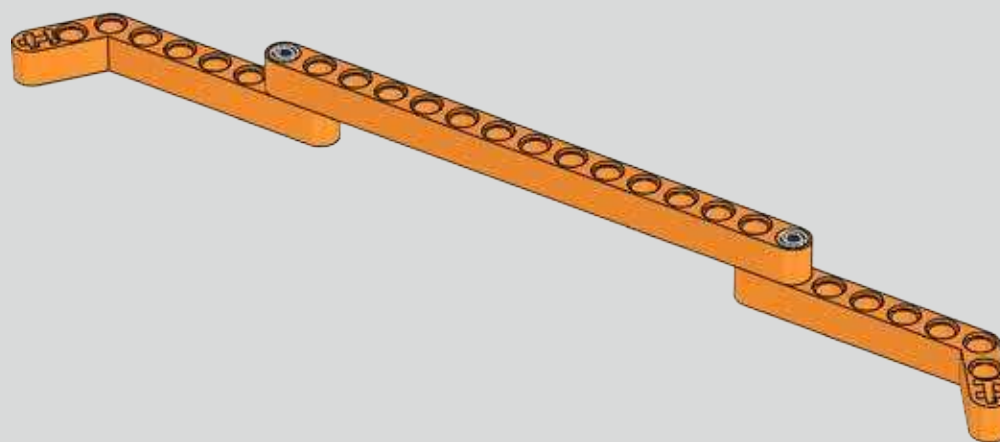



625

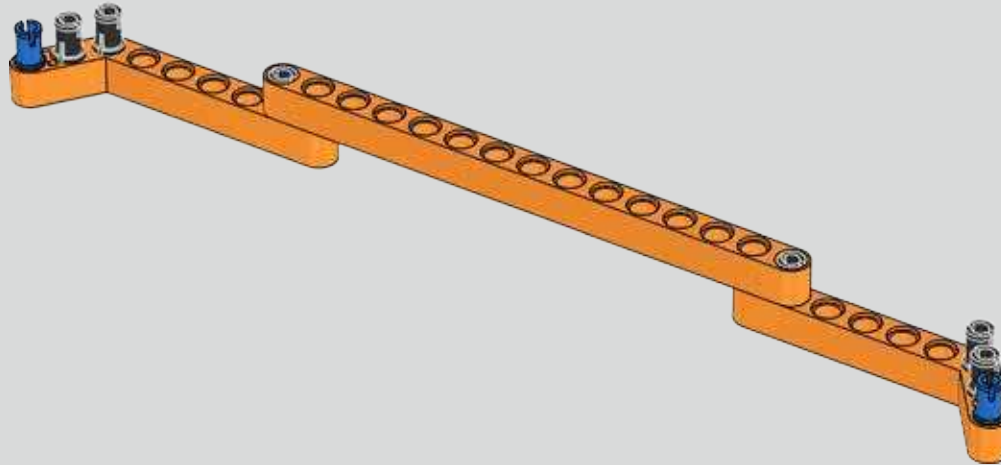

626

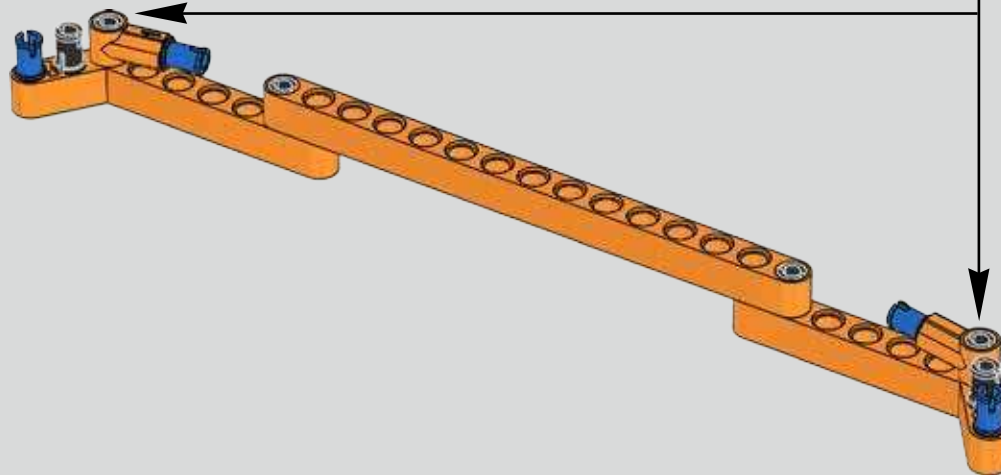
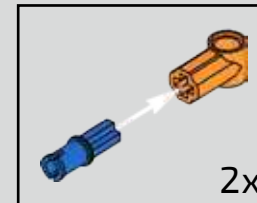

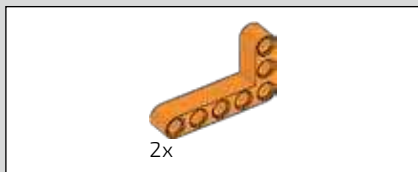

627

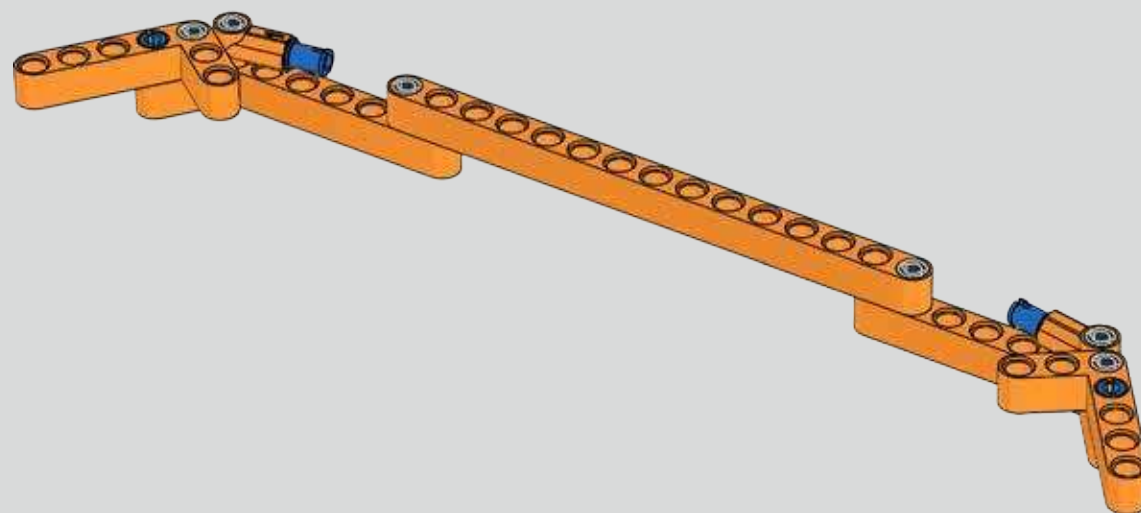

628

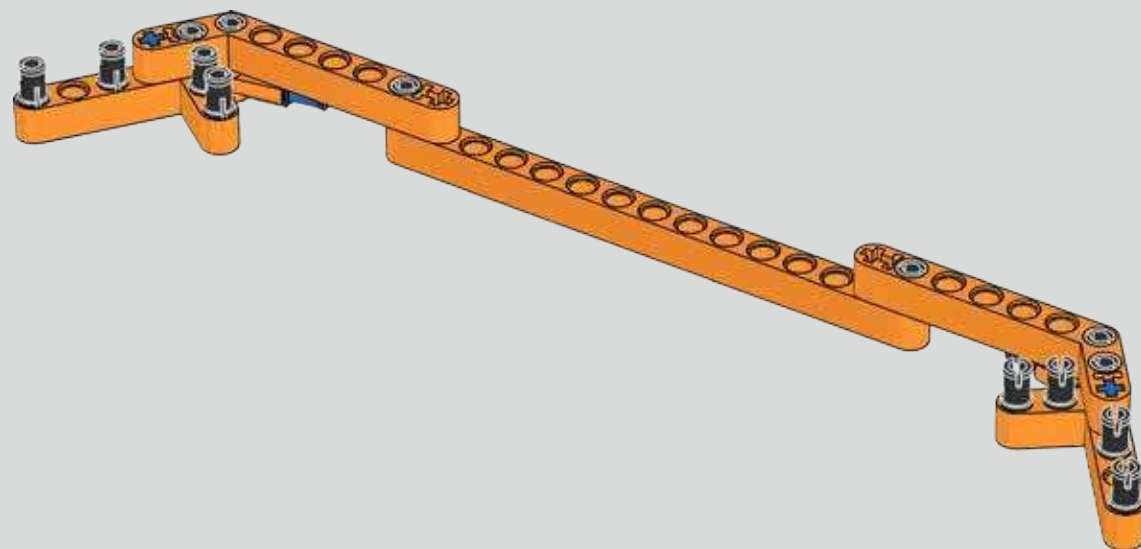
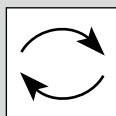

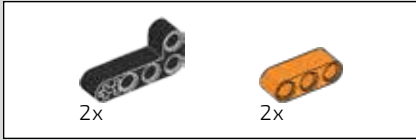

629

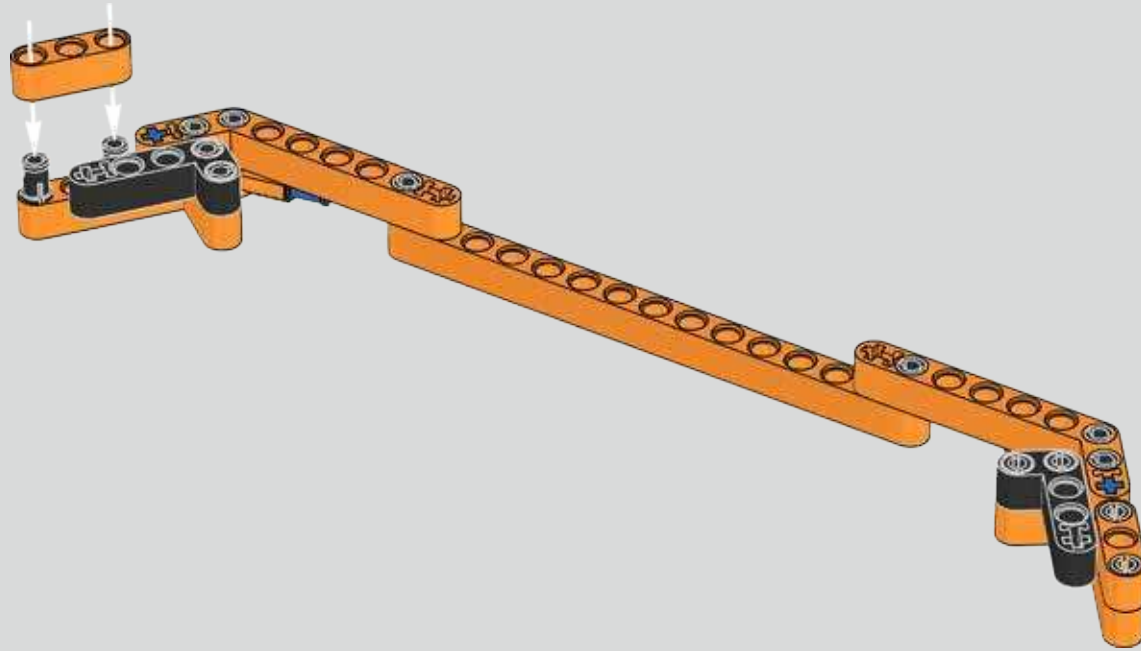

630

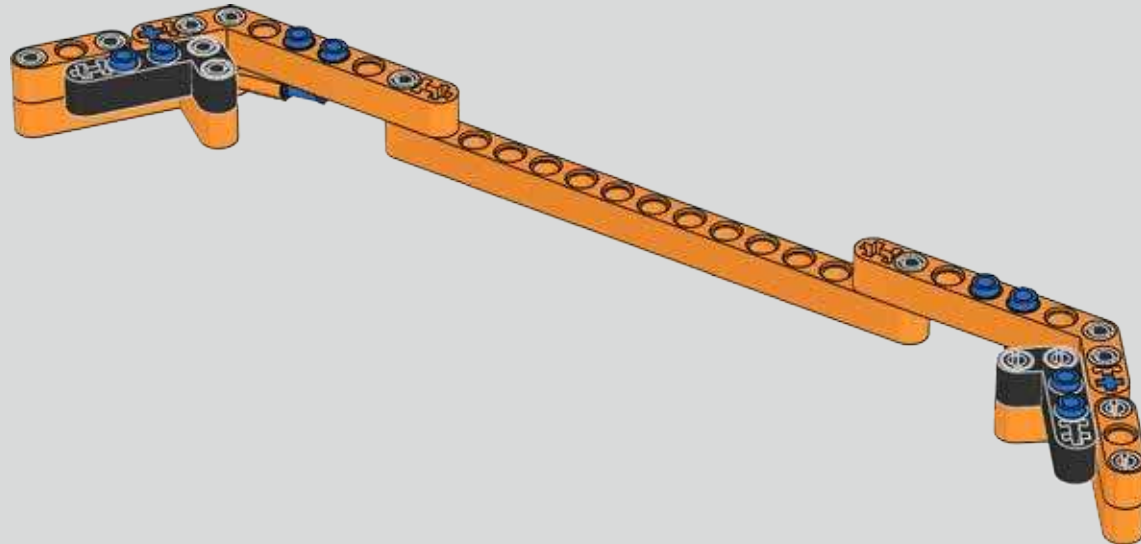

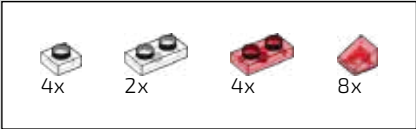

631

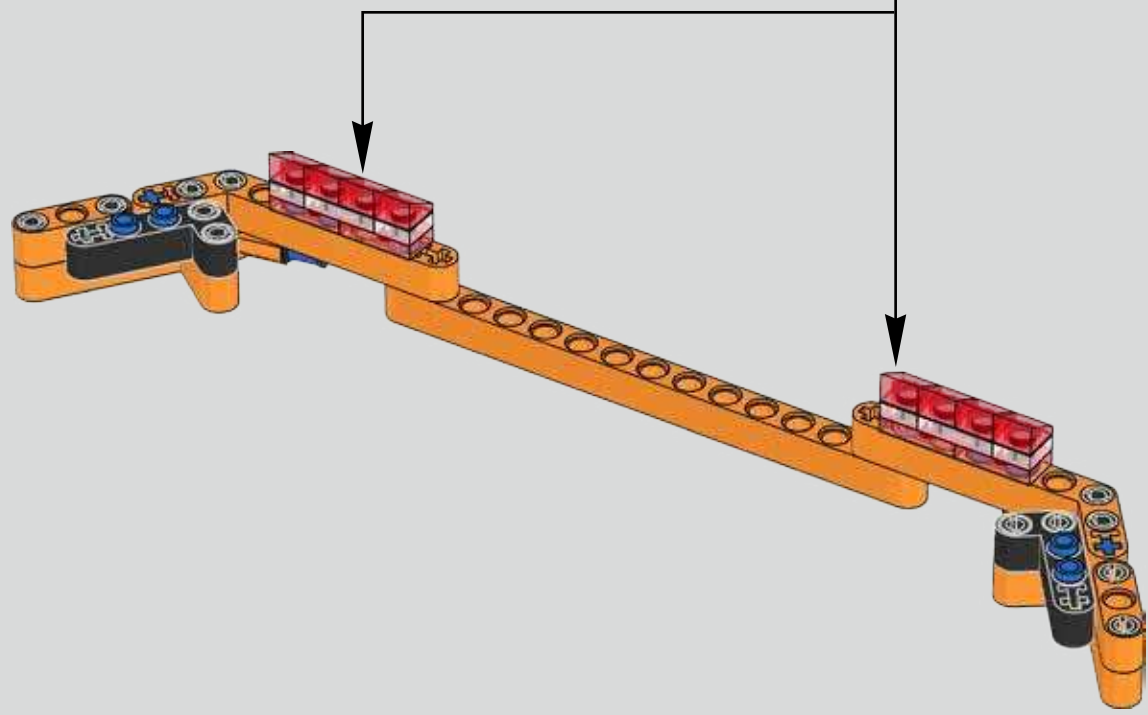
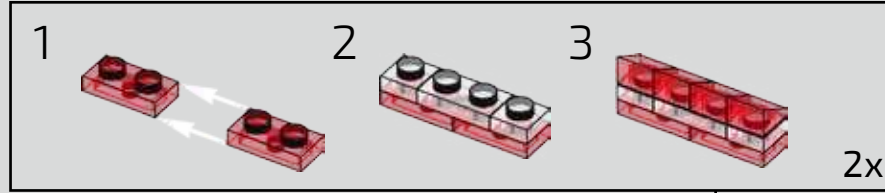



632

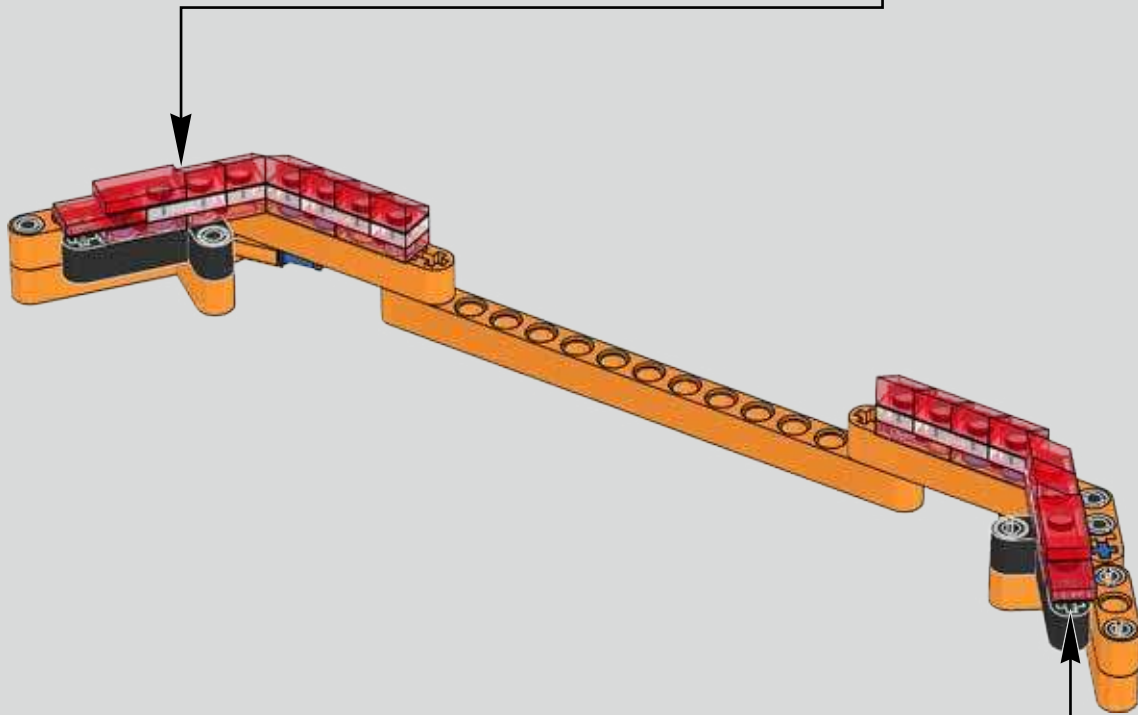
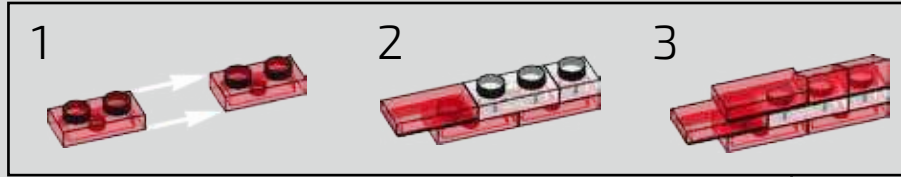

633

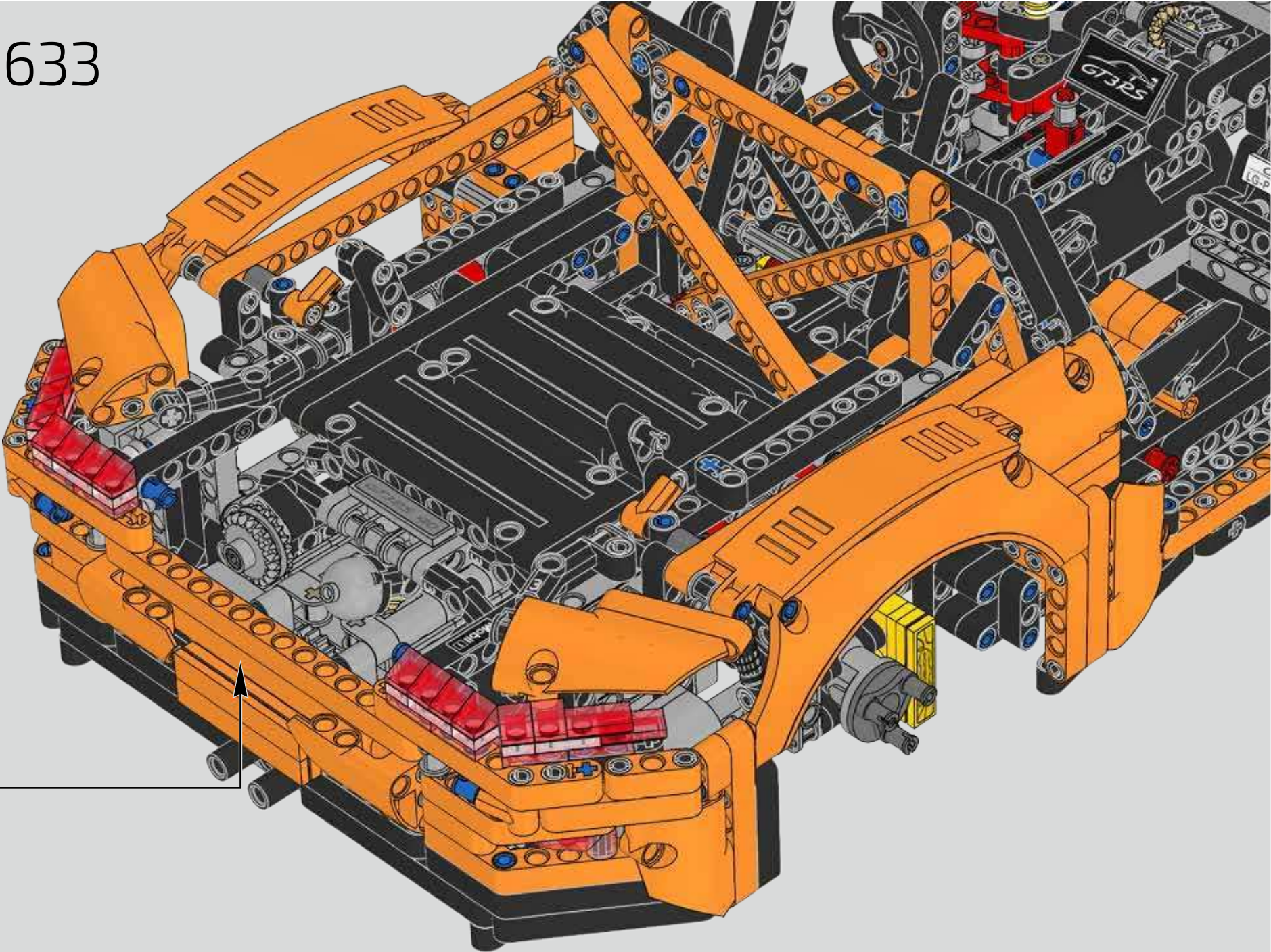



634

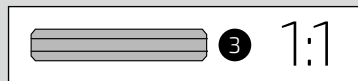
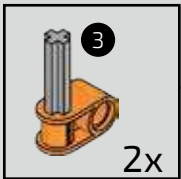
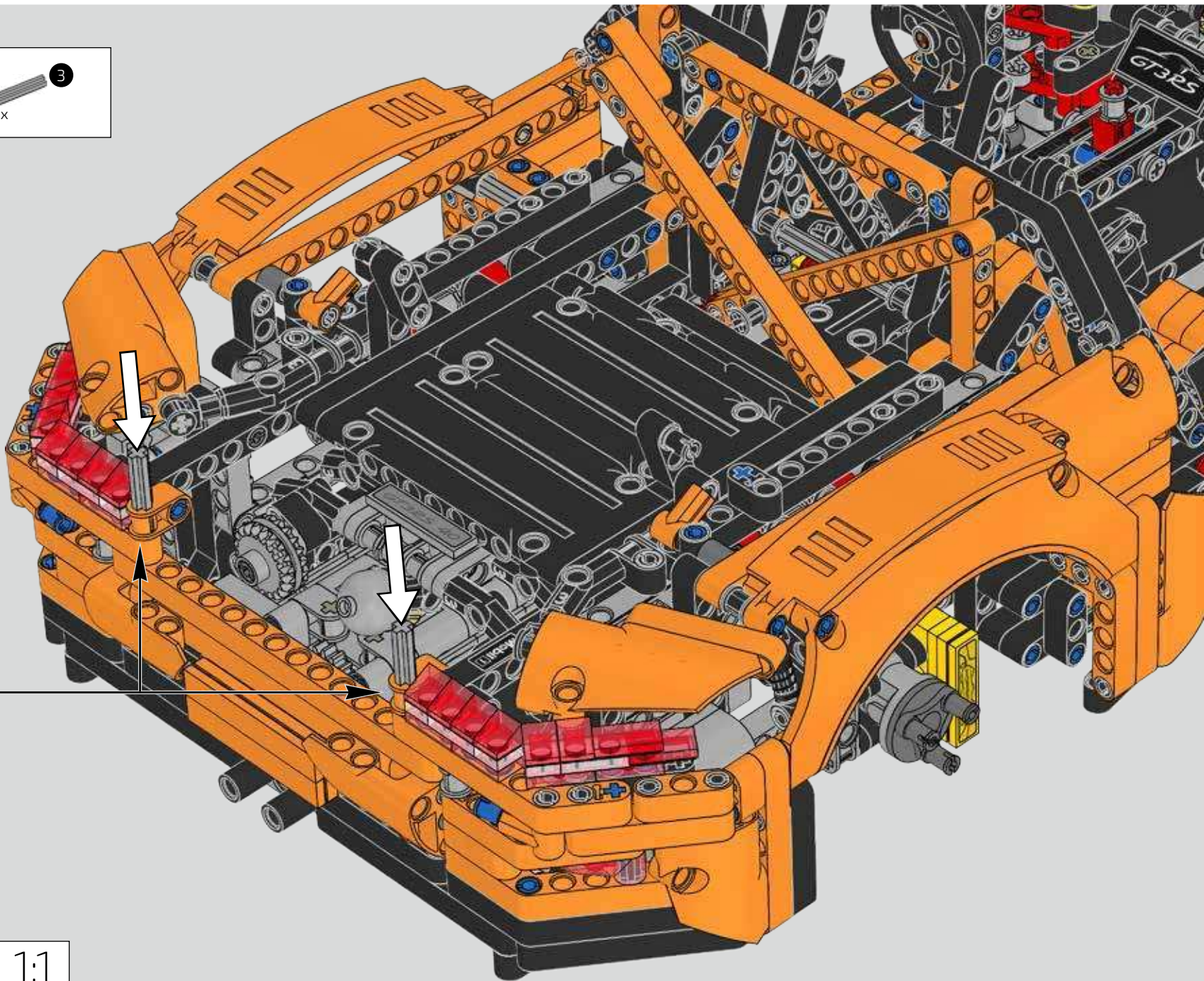

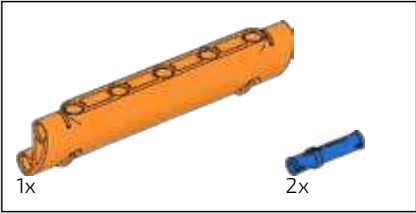

635

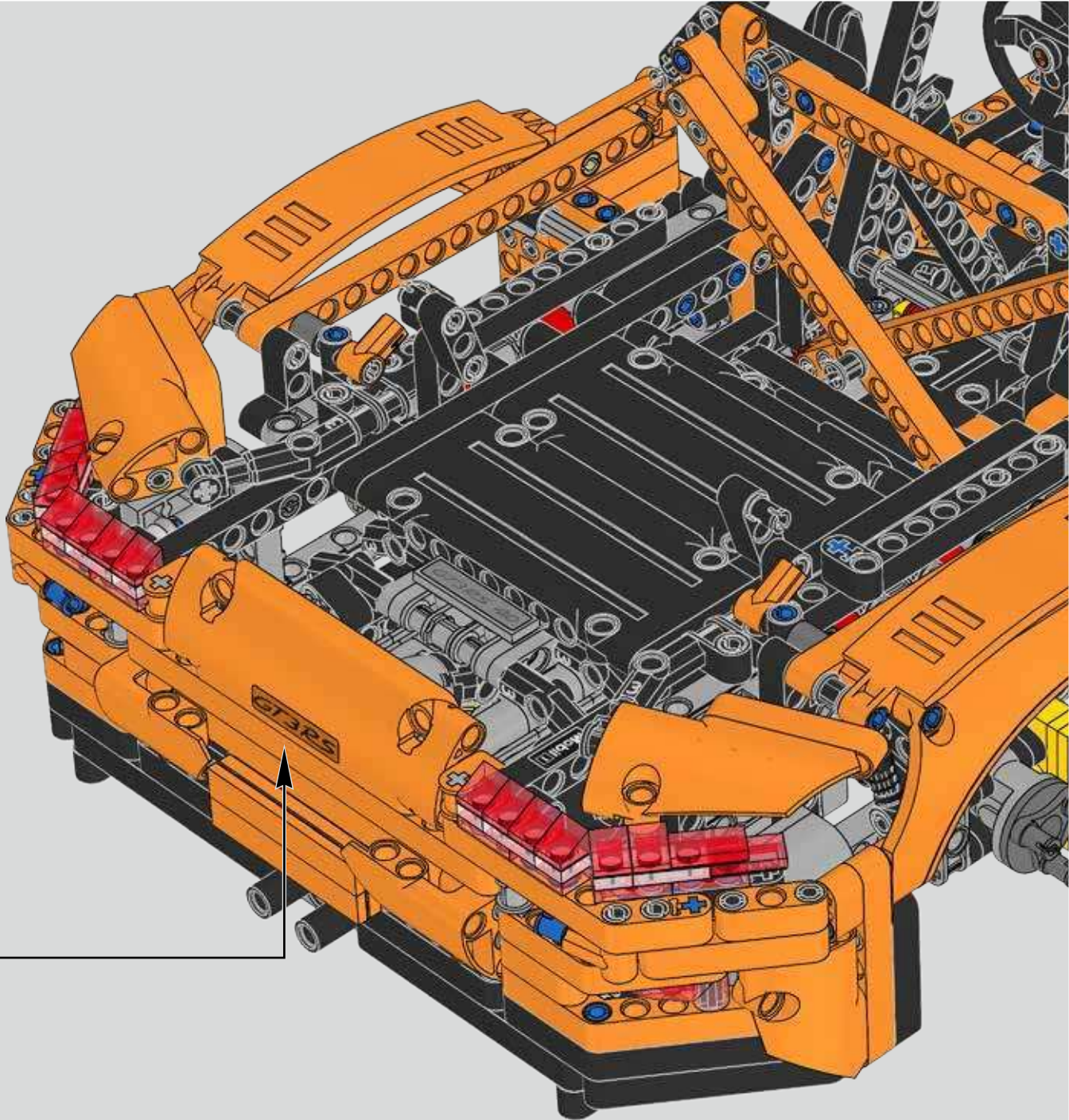
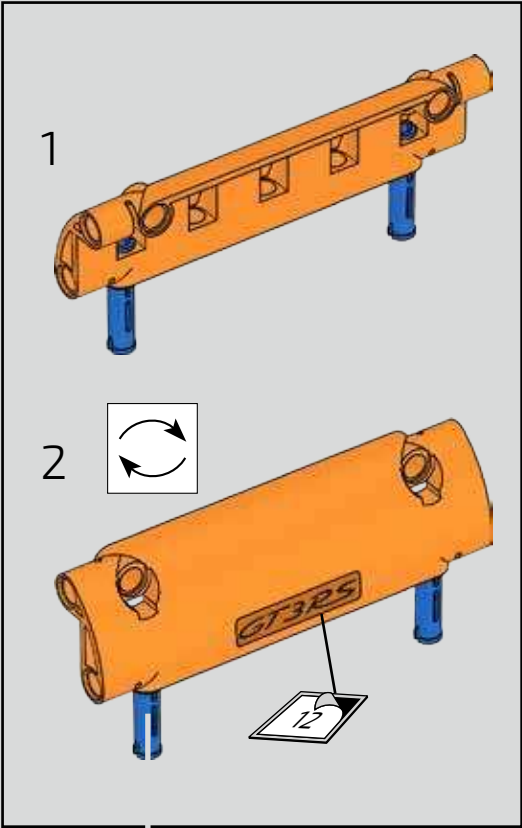

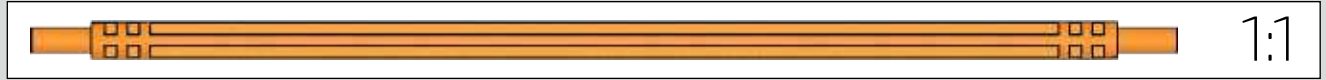
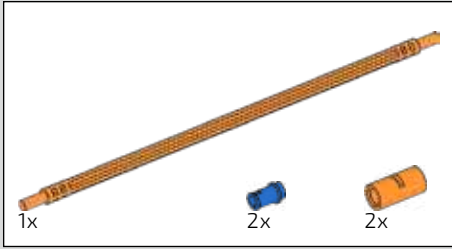

636

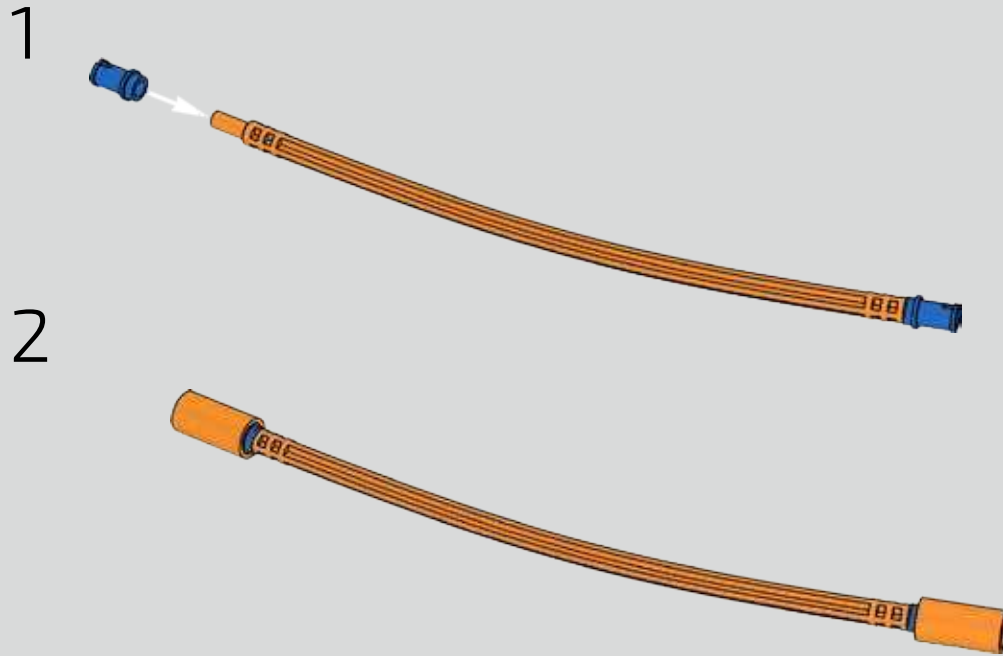

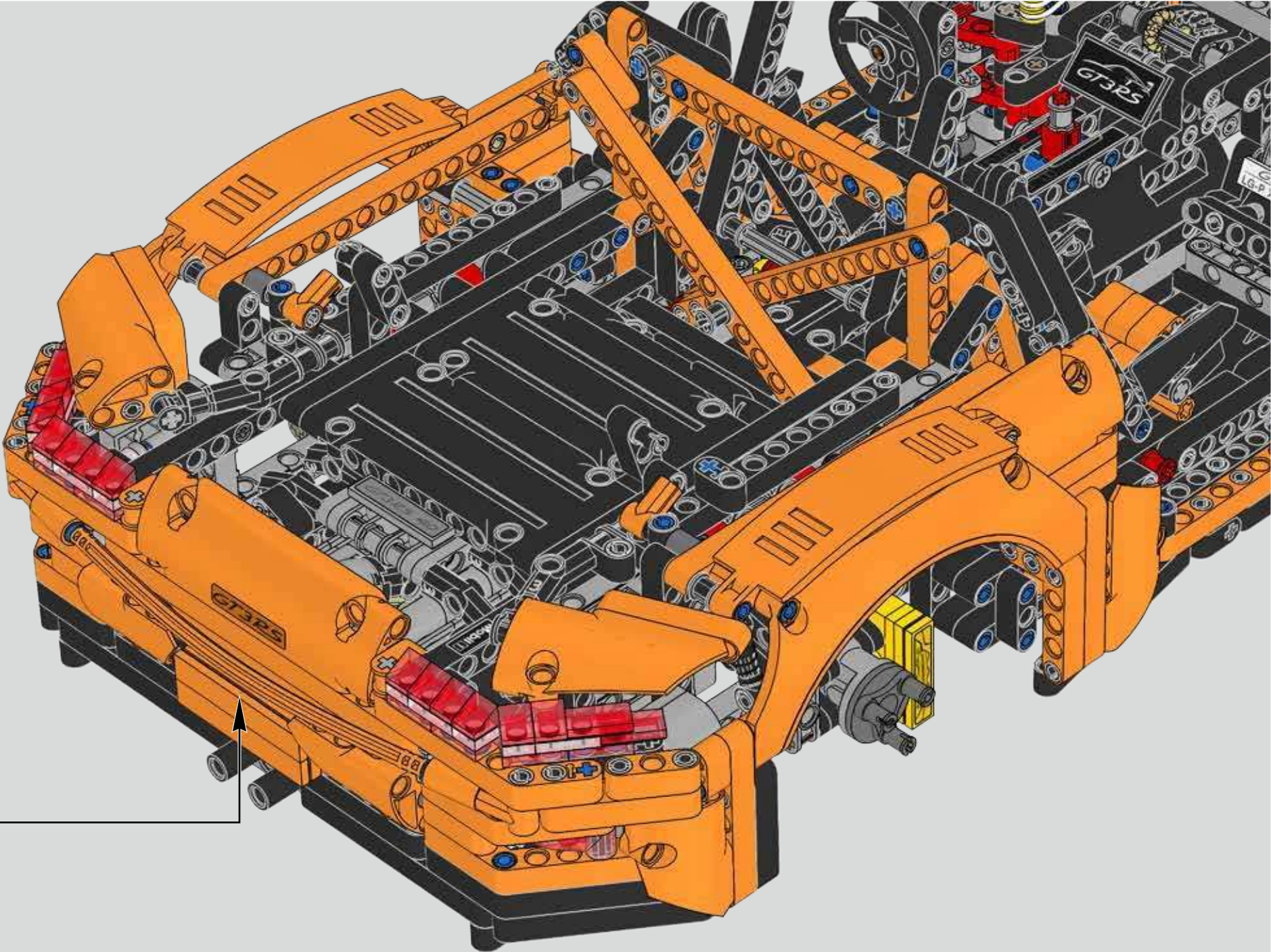

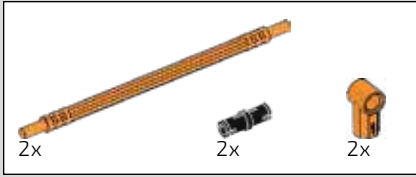

637

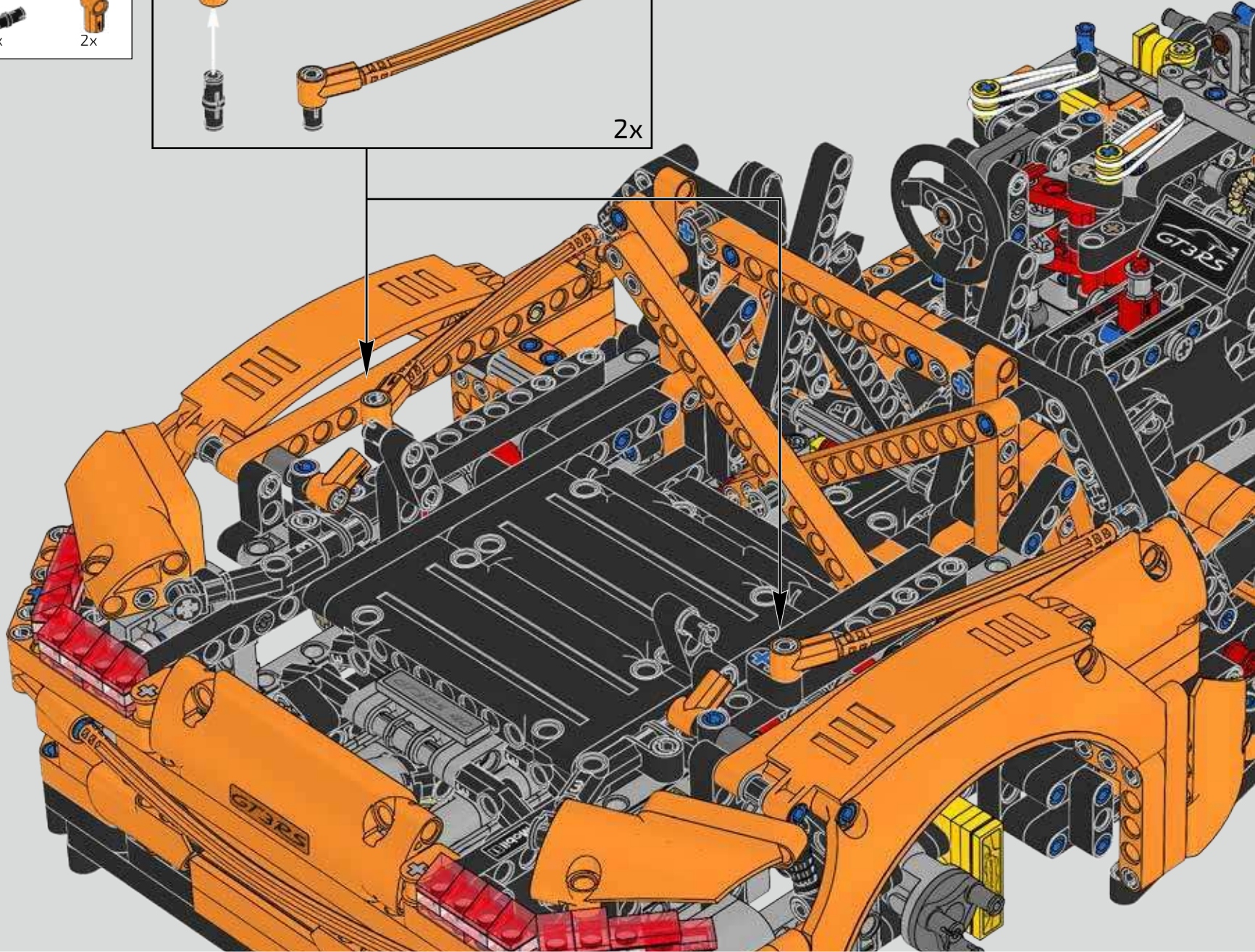
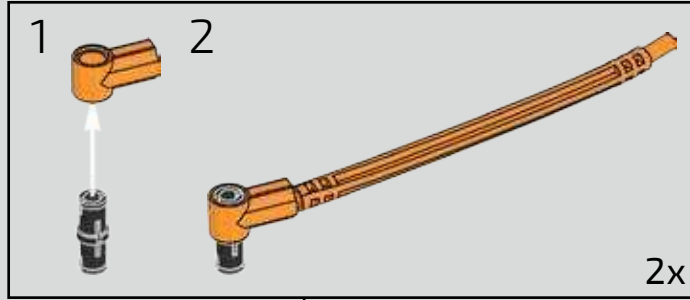

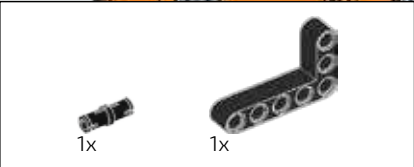

638

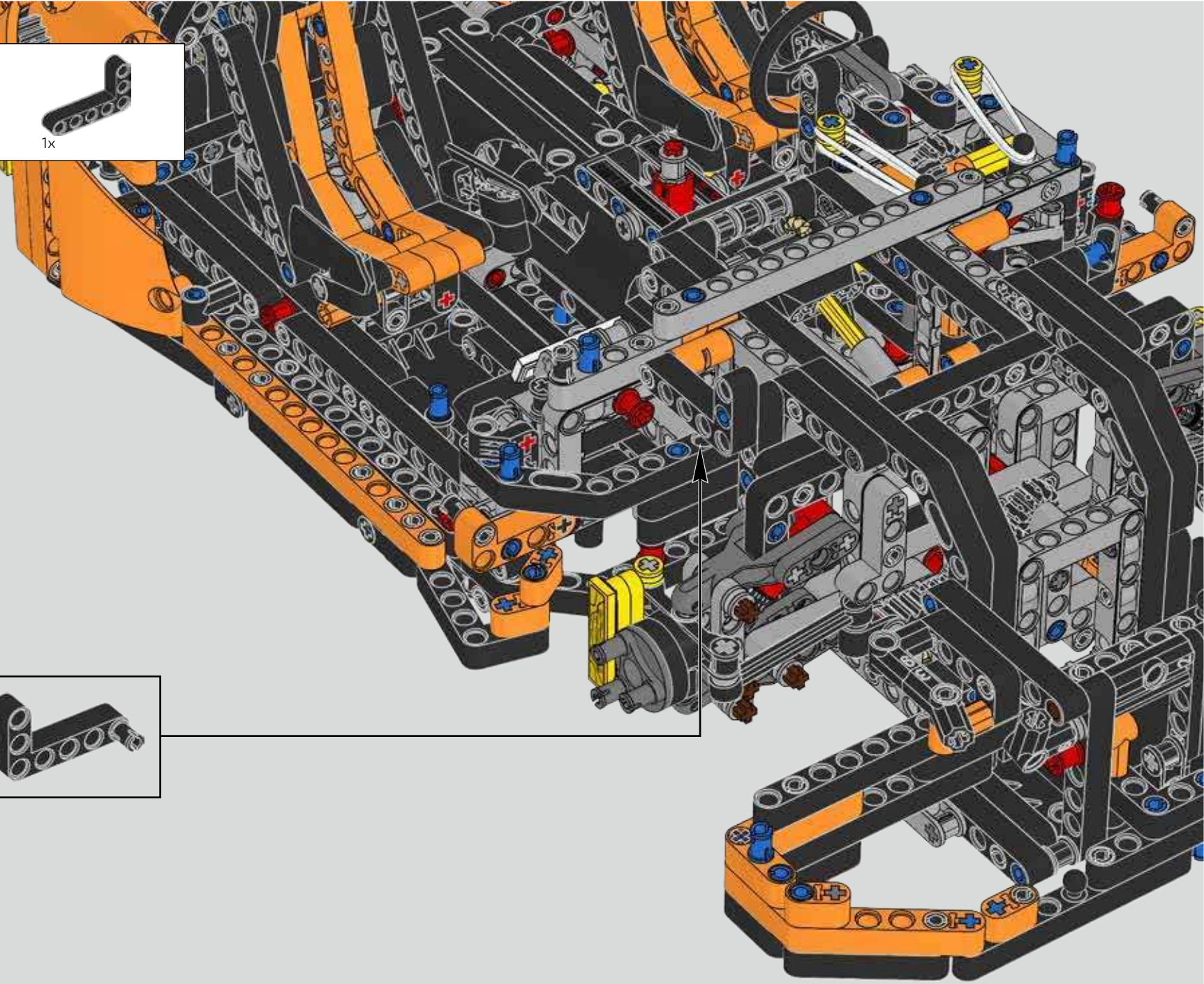
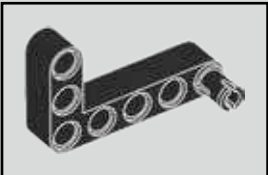
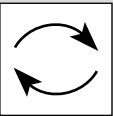

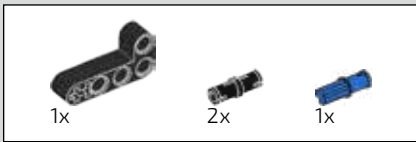

639



640

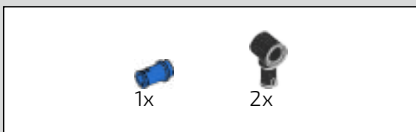

641

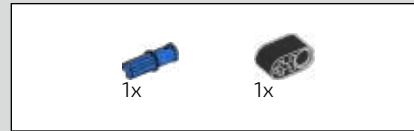

642

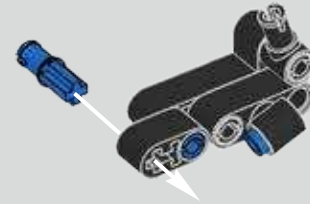

643

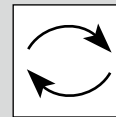

644

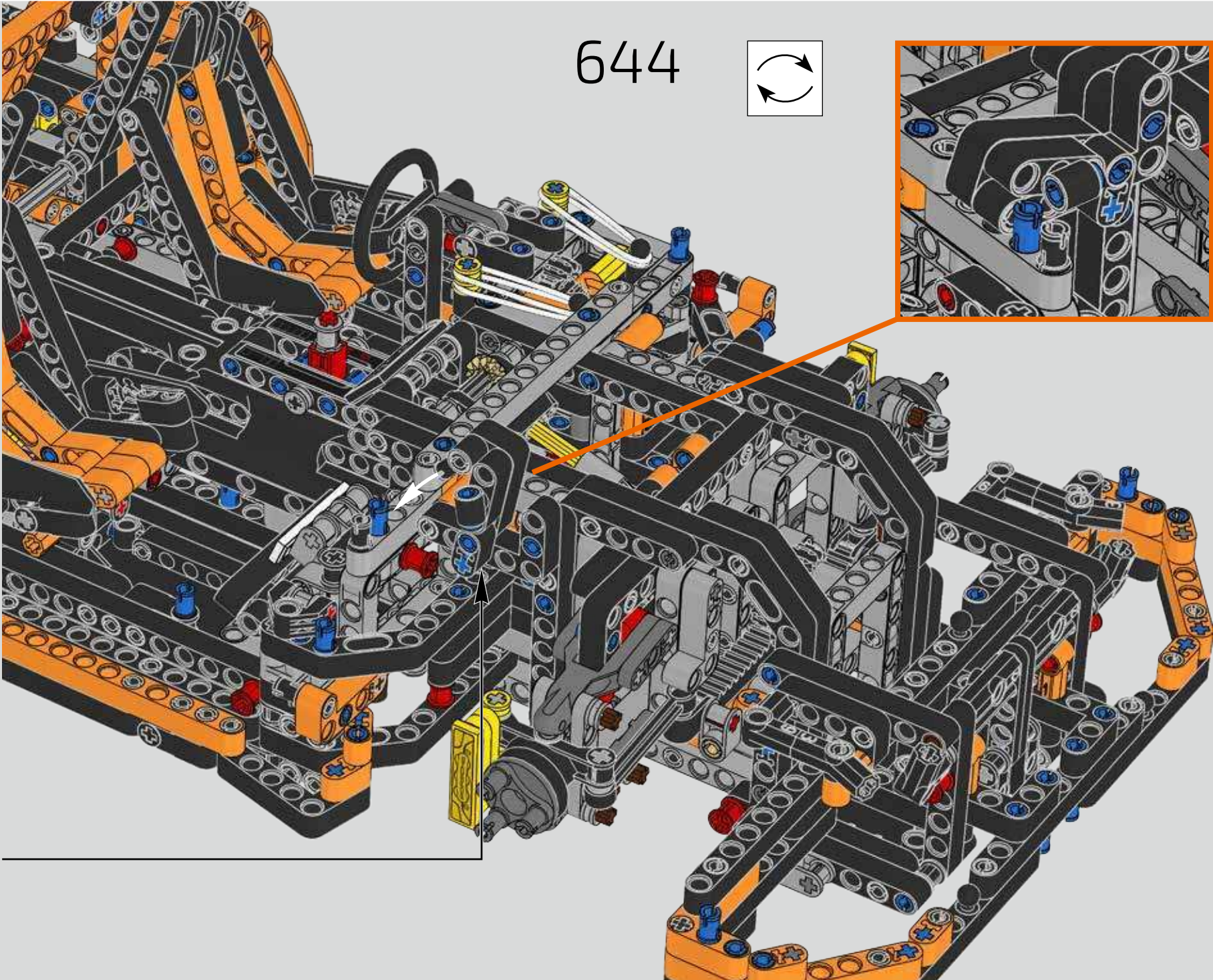
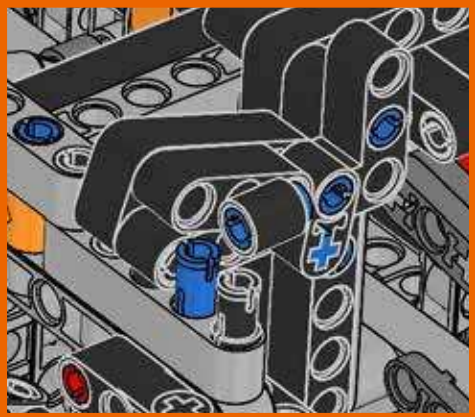
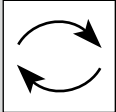

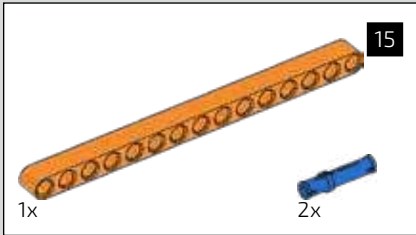
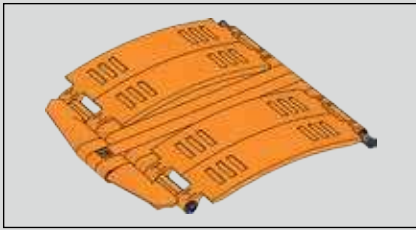

645

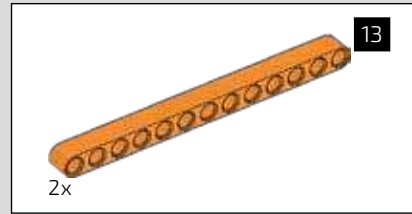
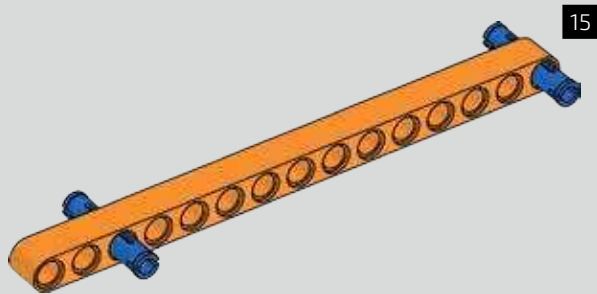

646

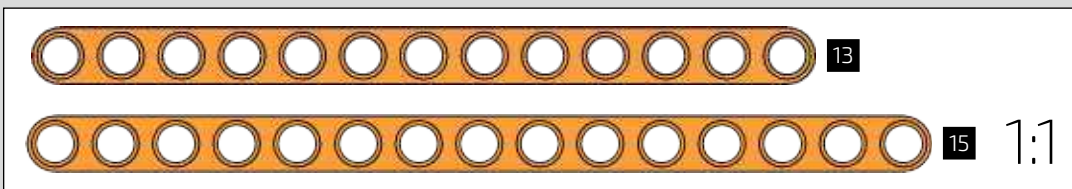
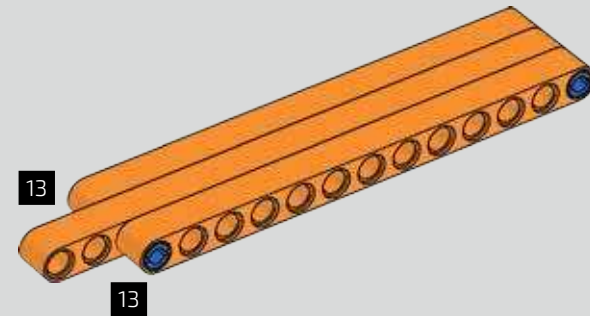



647

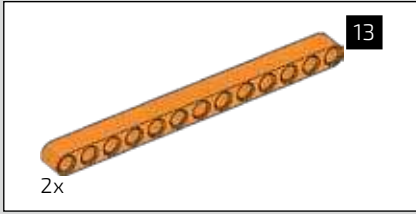
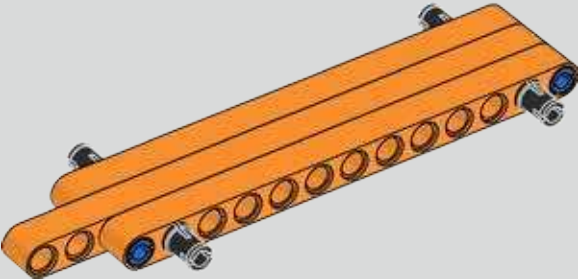

648

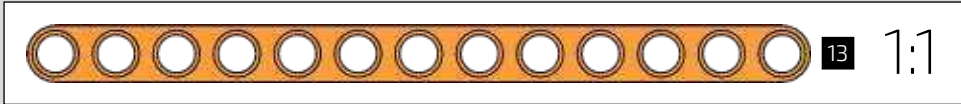
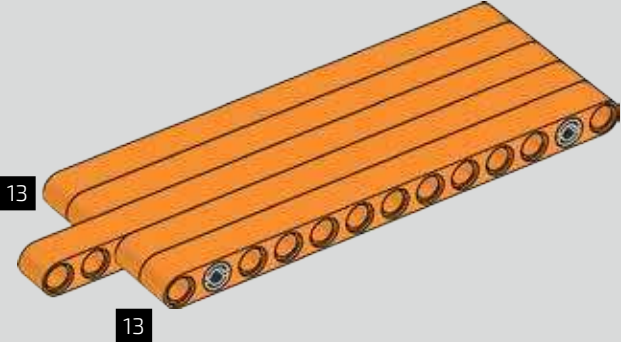

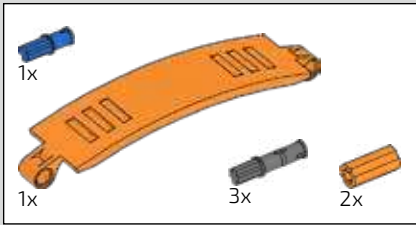

649

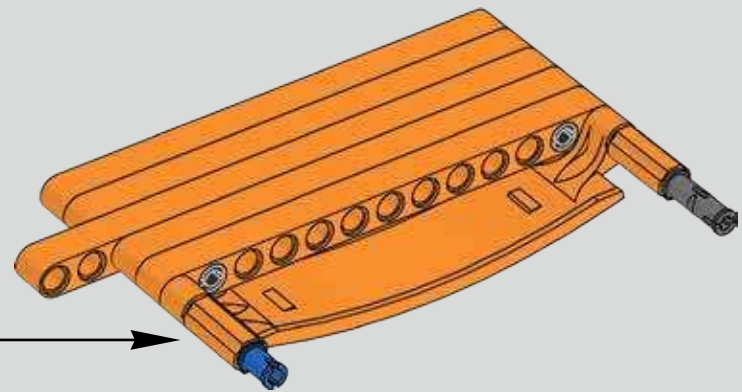
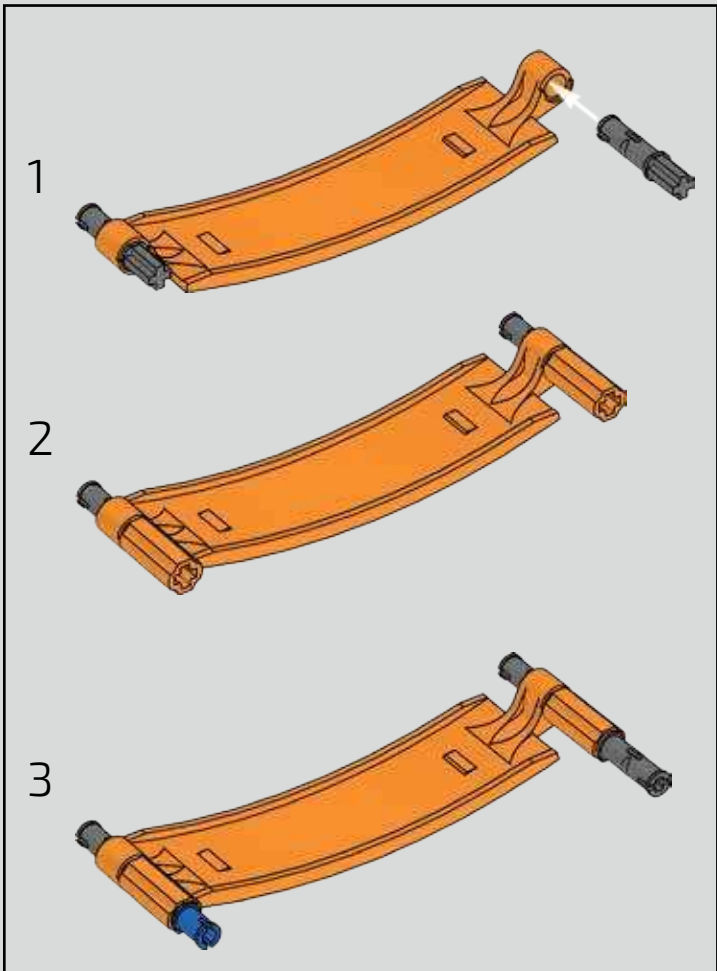

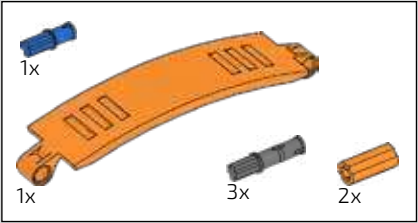

650

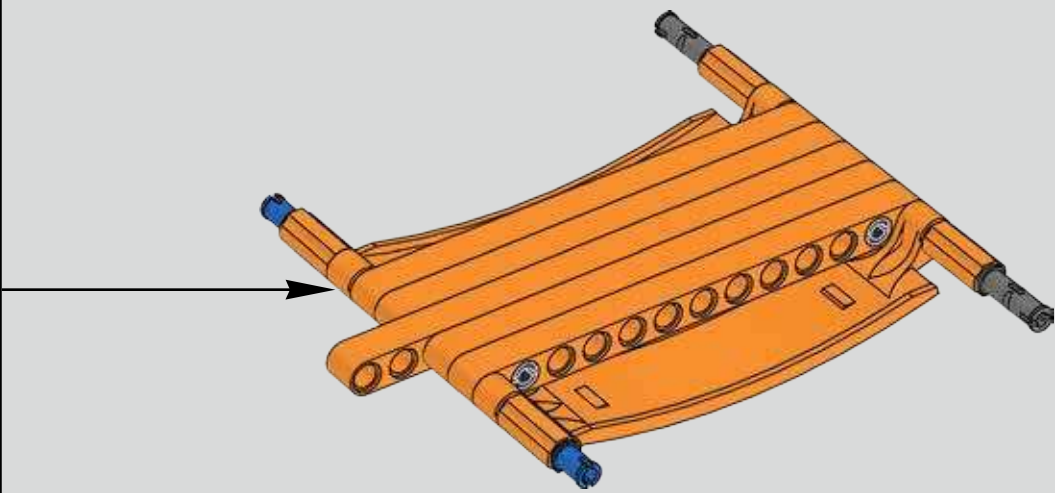
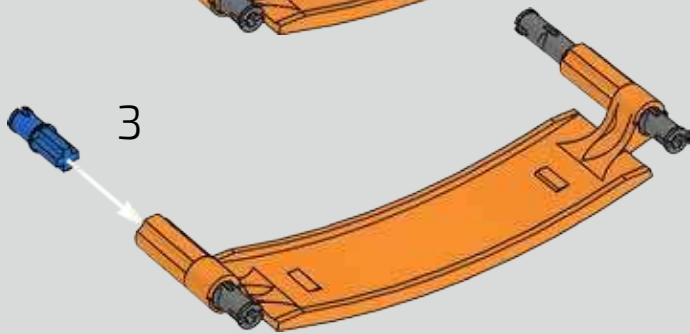
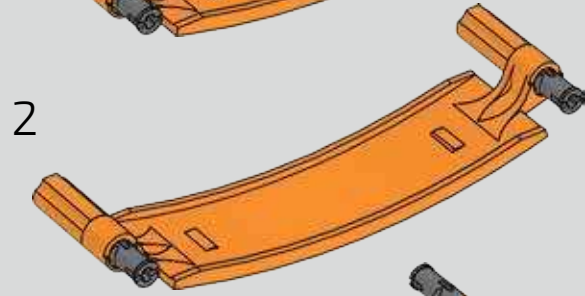
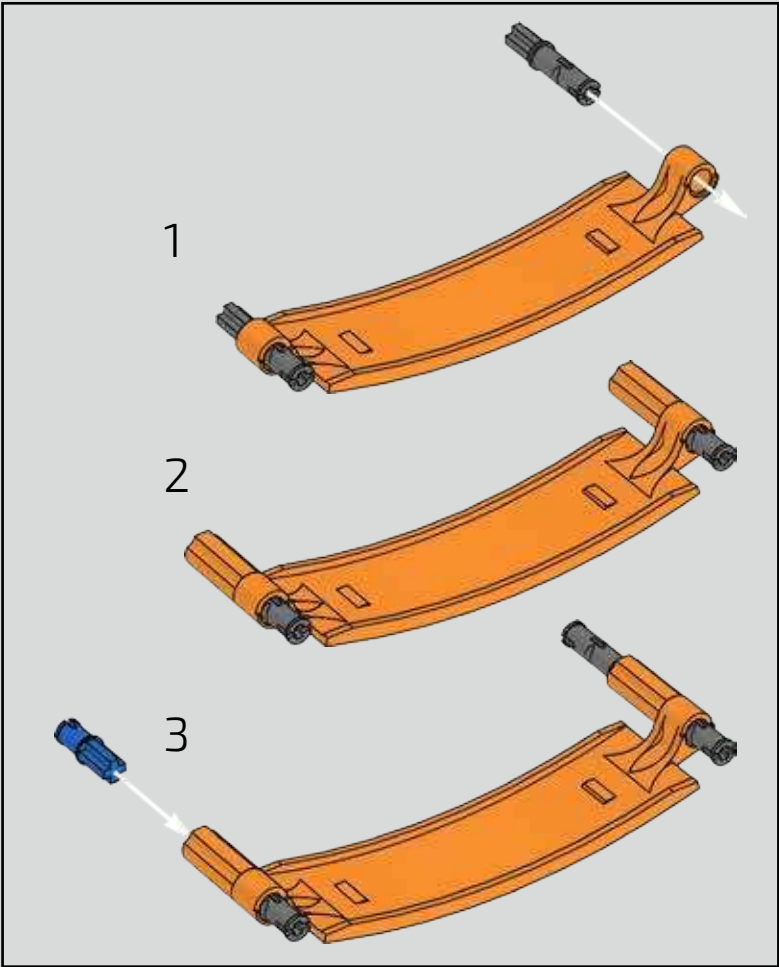

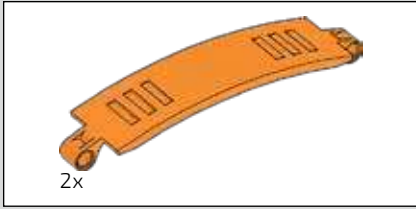

651

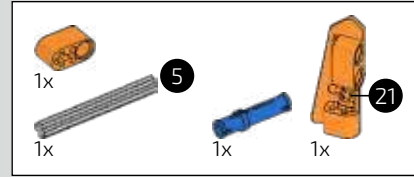
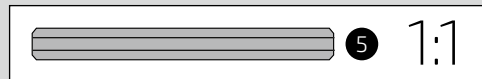
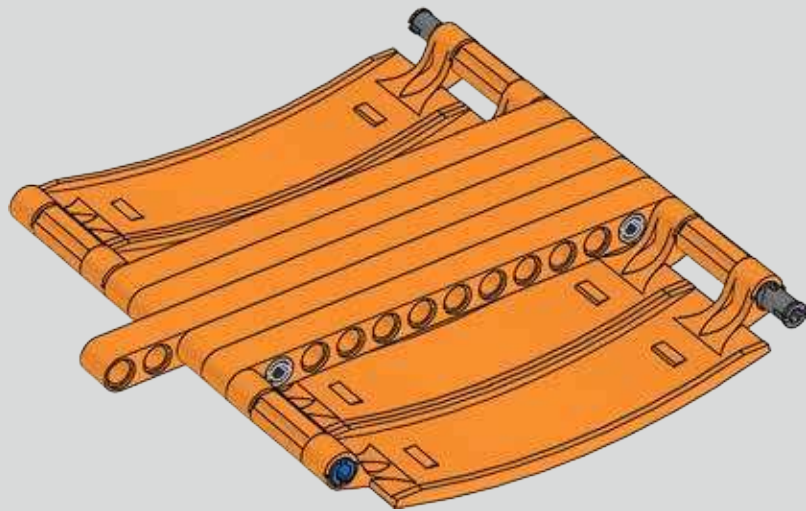

652

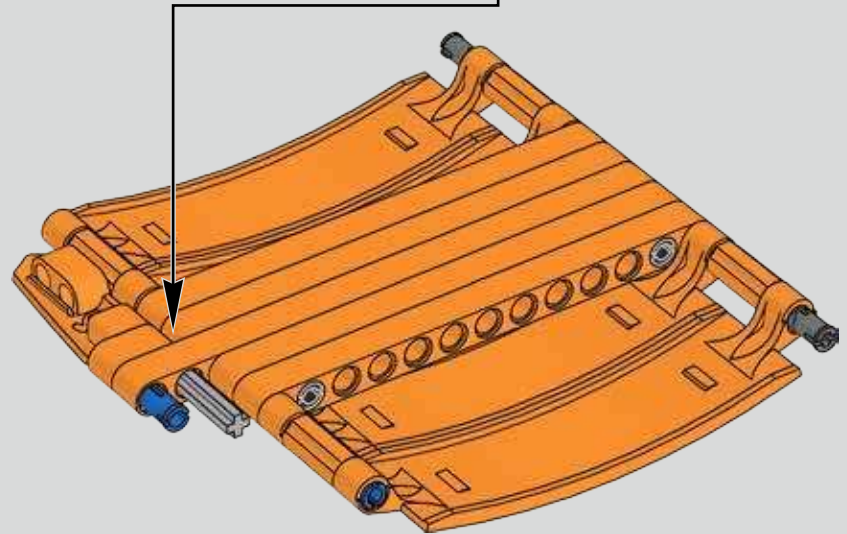
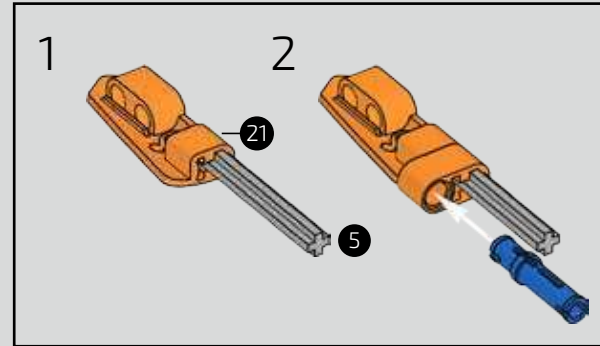

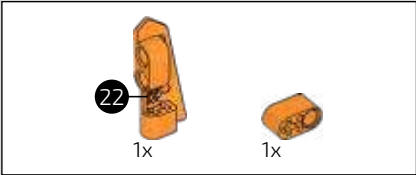

653

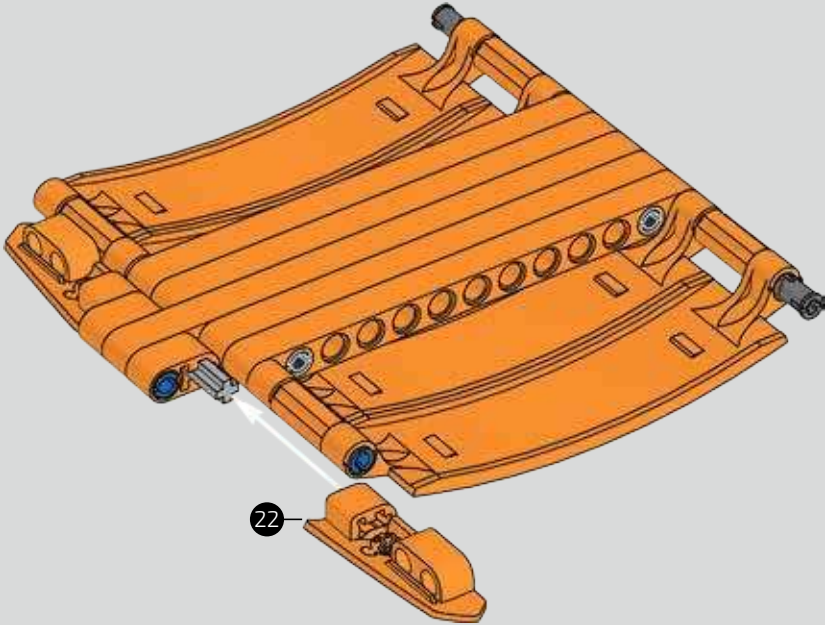

654

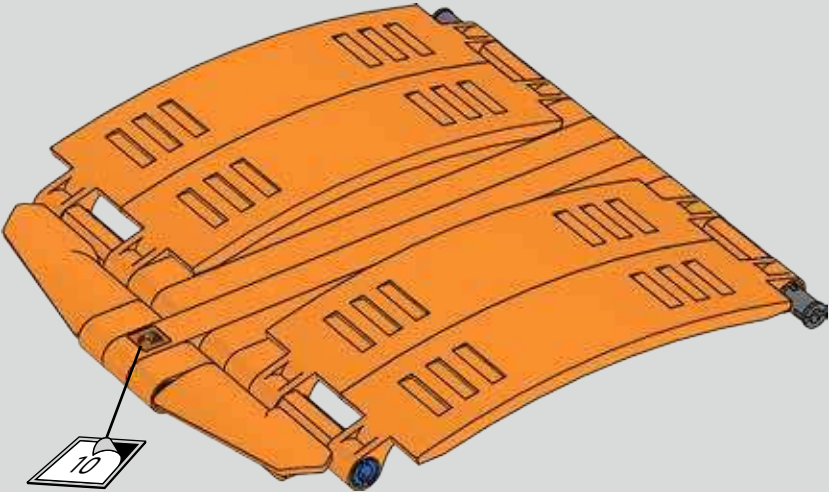
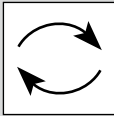

655

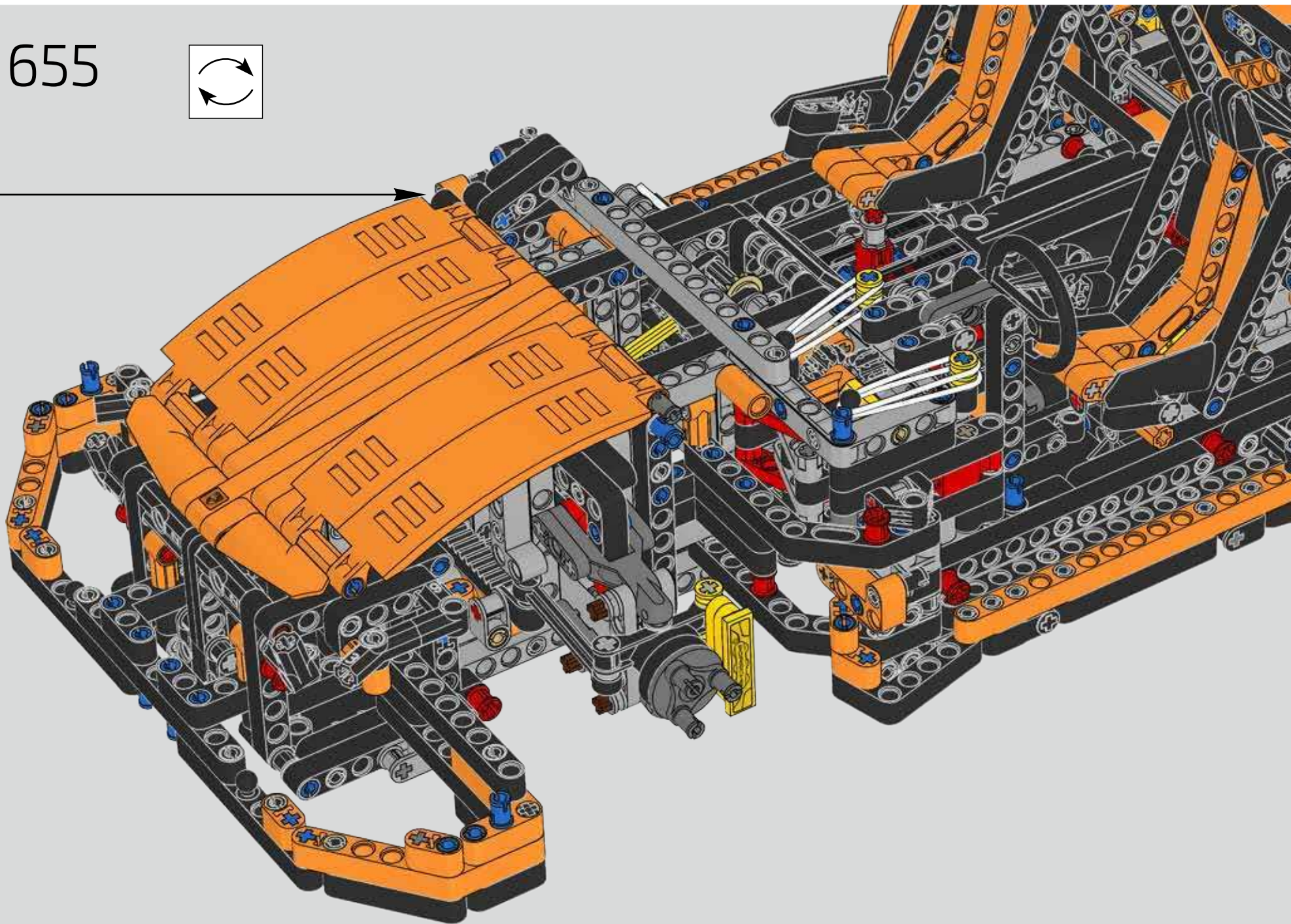
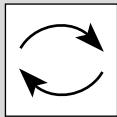

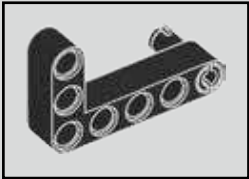
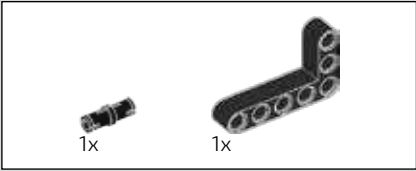

656

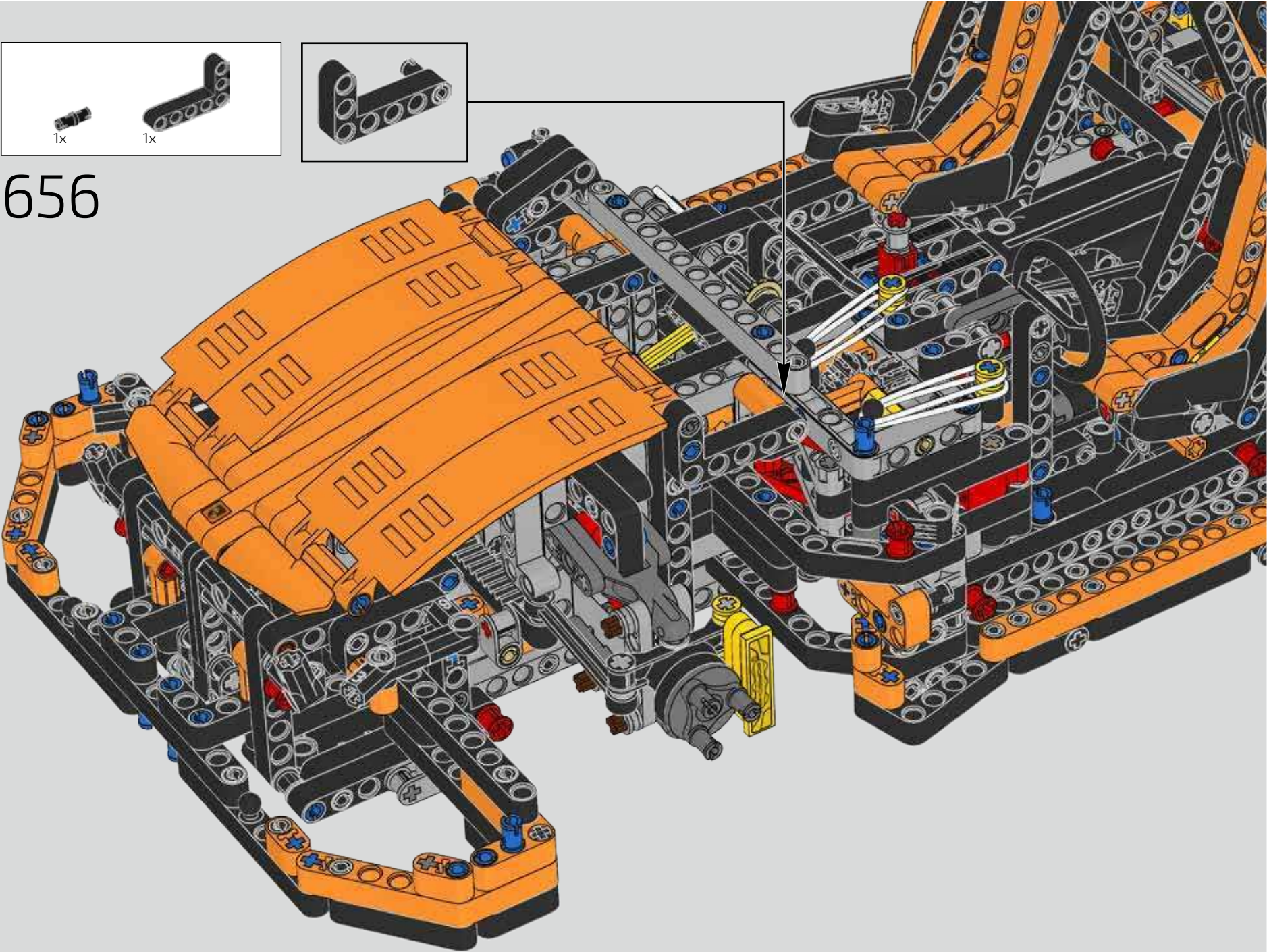

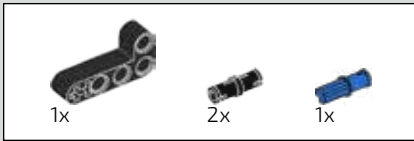

657



658

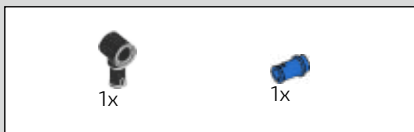

659



660



661

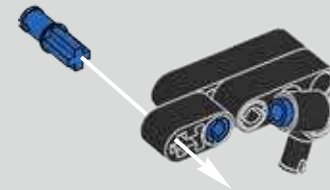

662

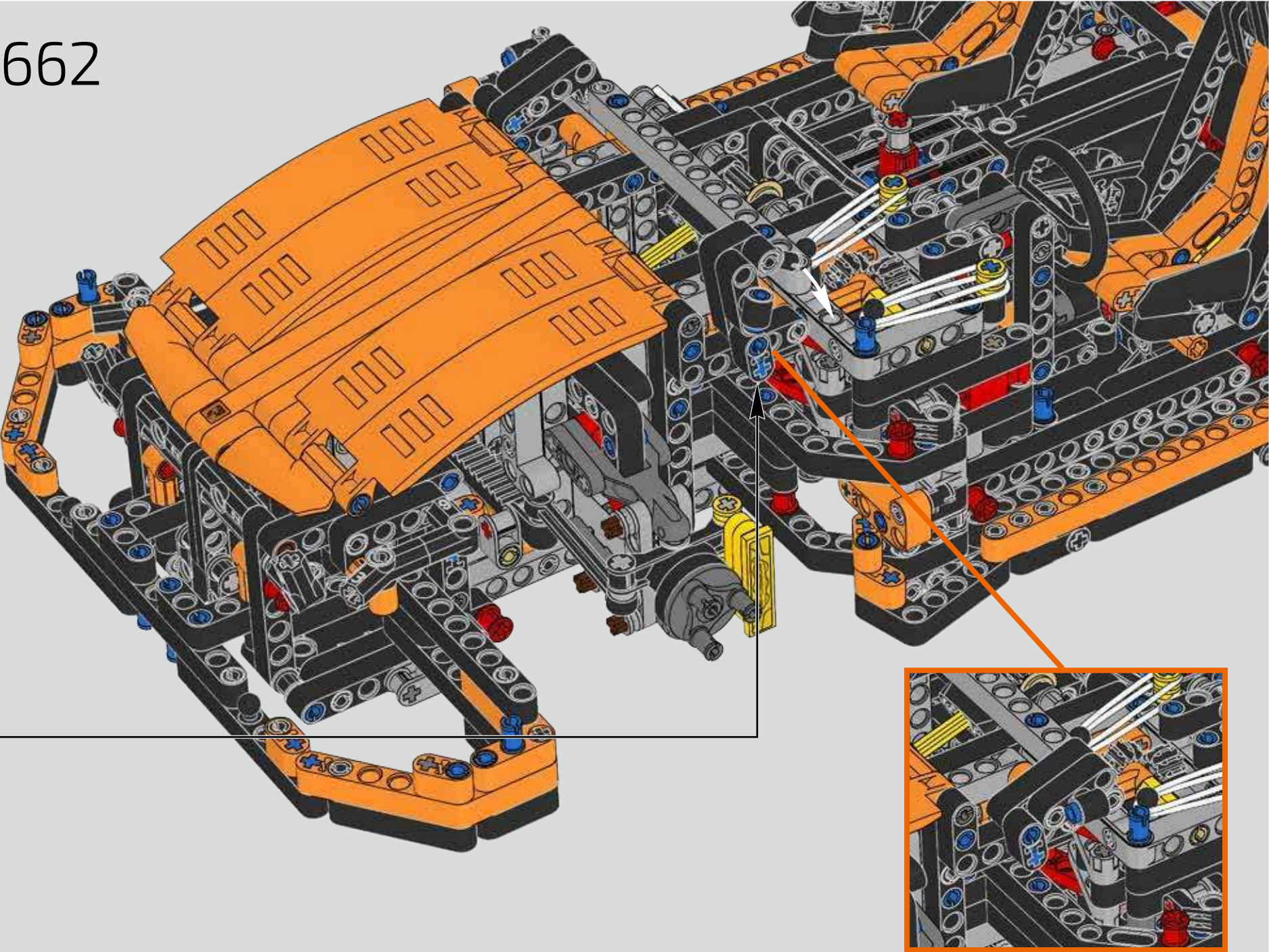



663

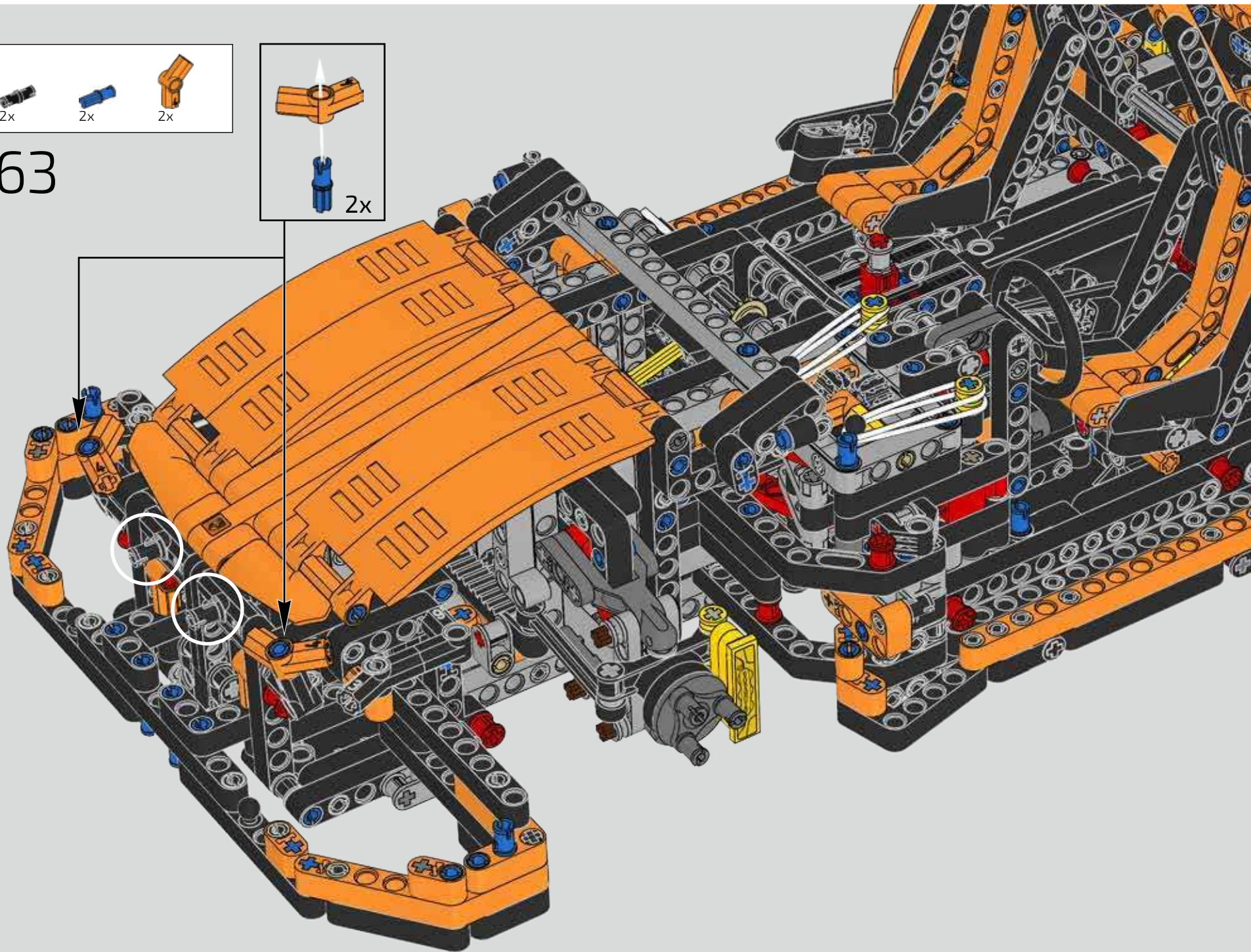

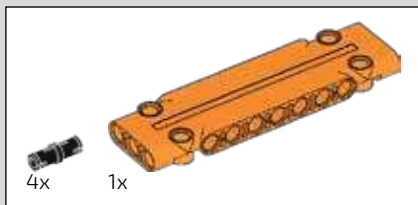
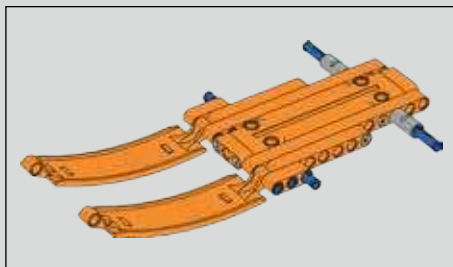

664

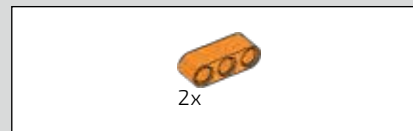
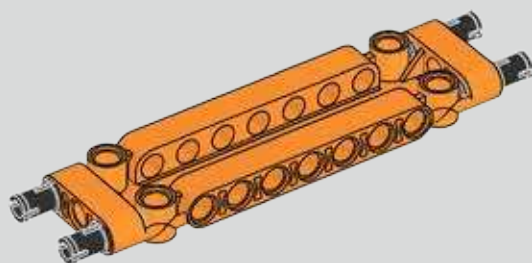

665

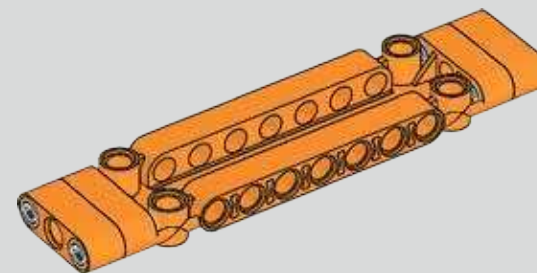

666

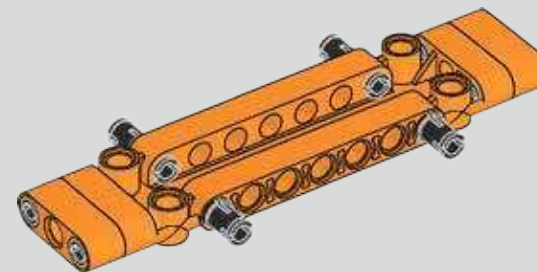

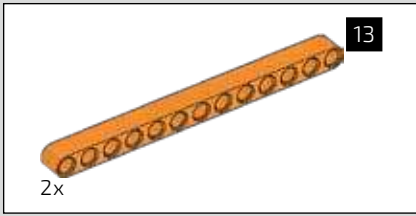

667

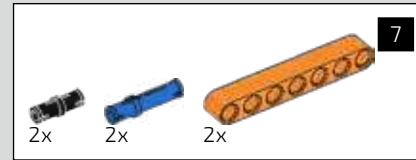
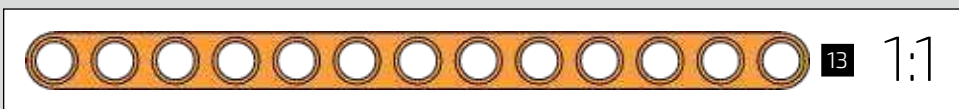
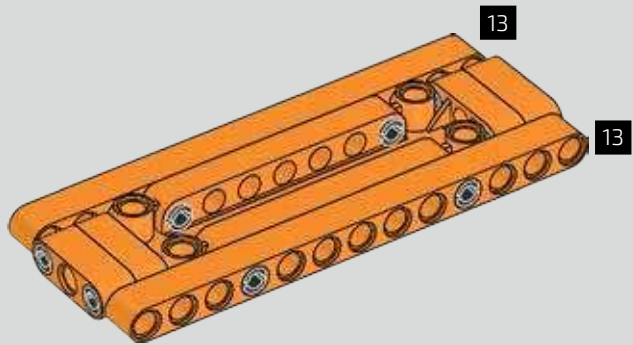

668

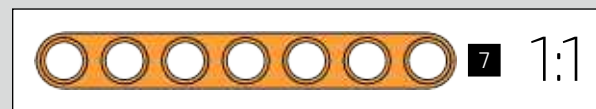
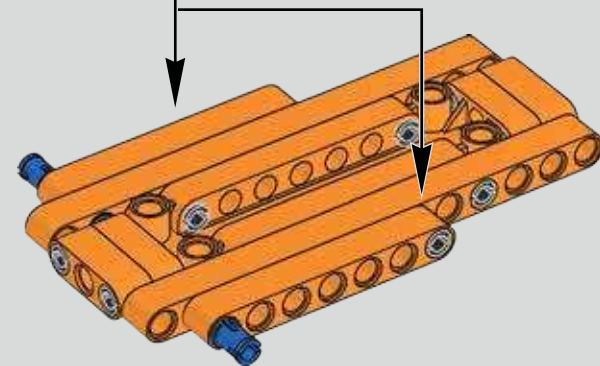
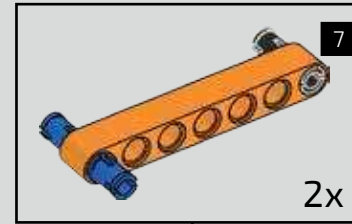



669

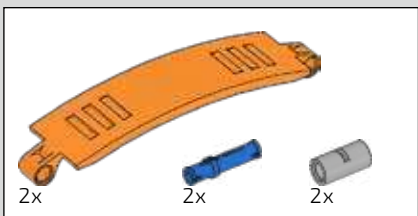
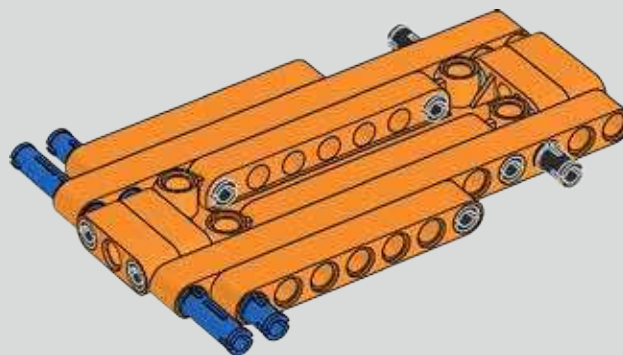

670

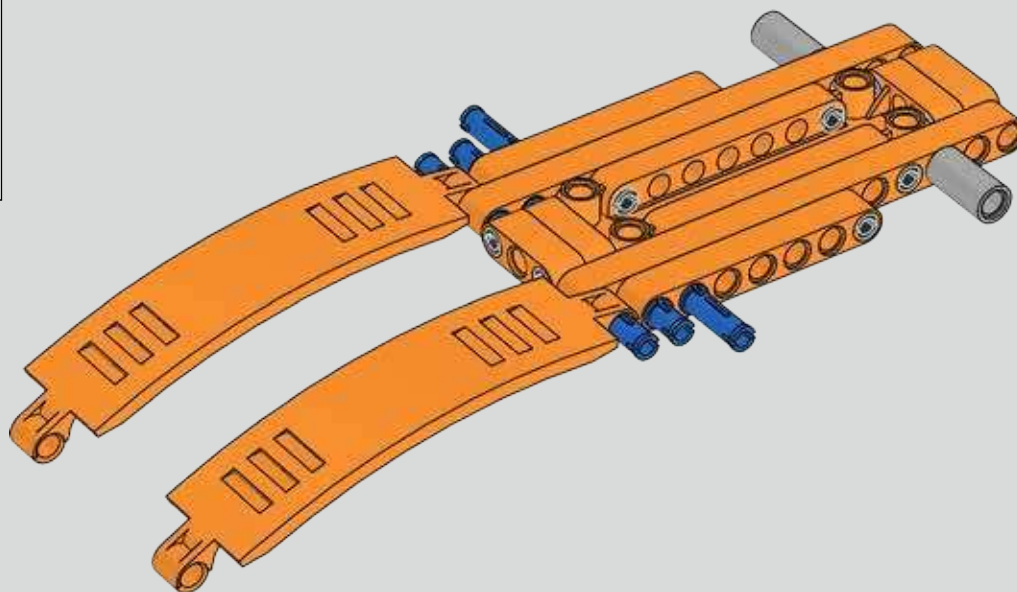

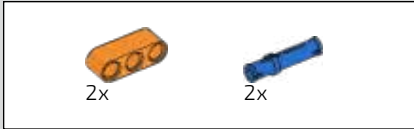

671

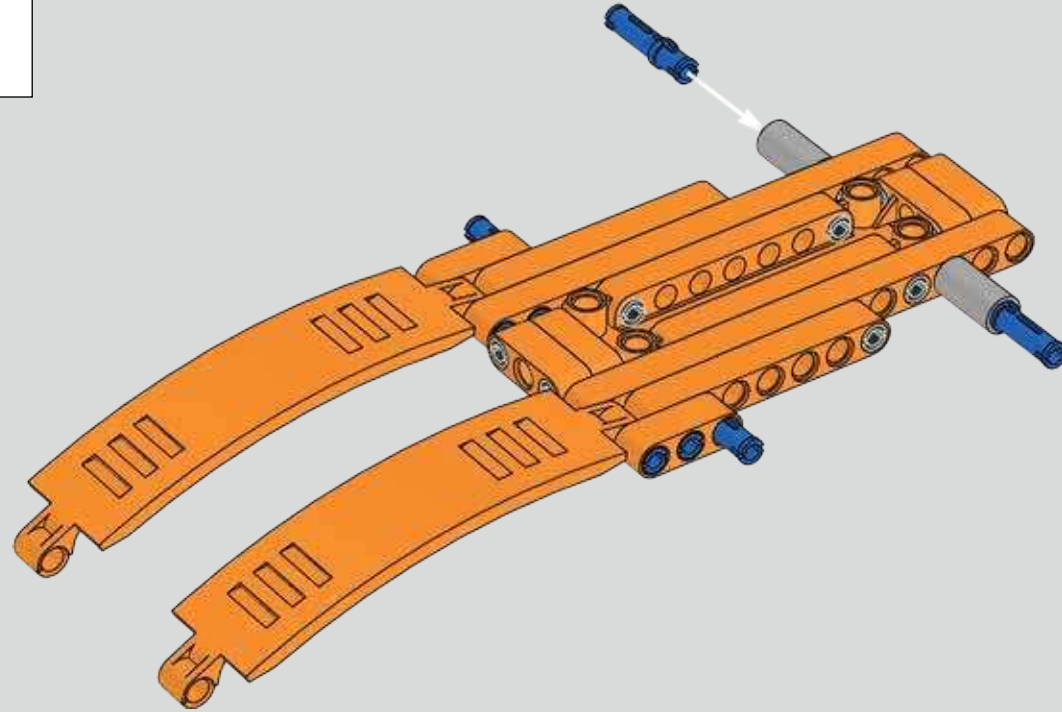

672

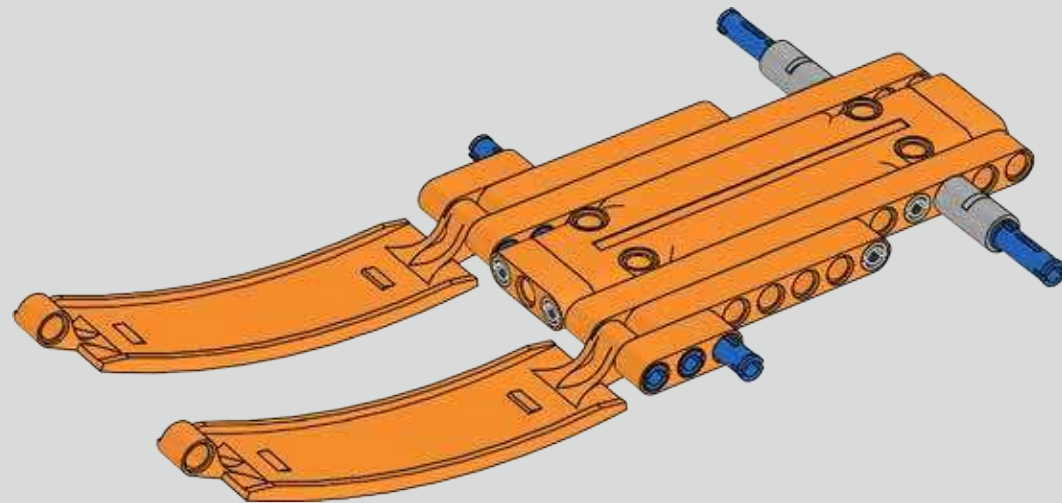
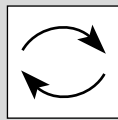



673

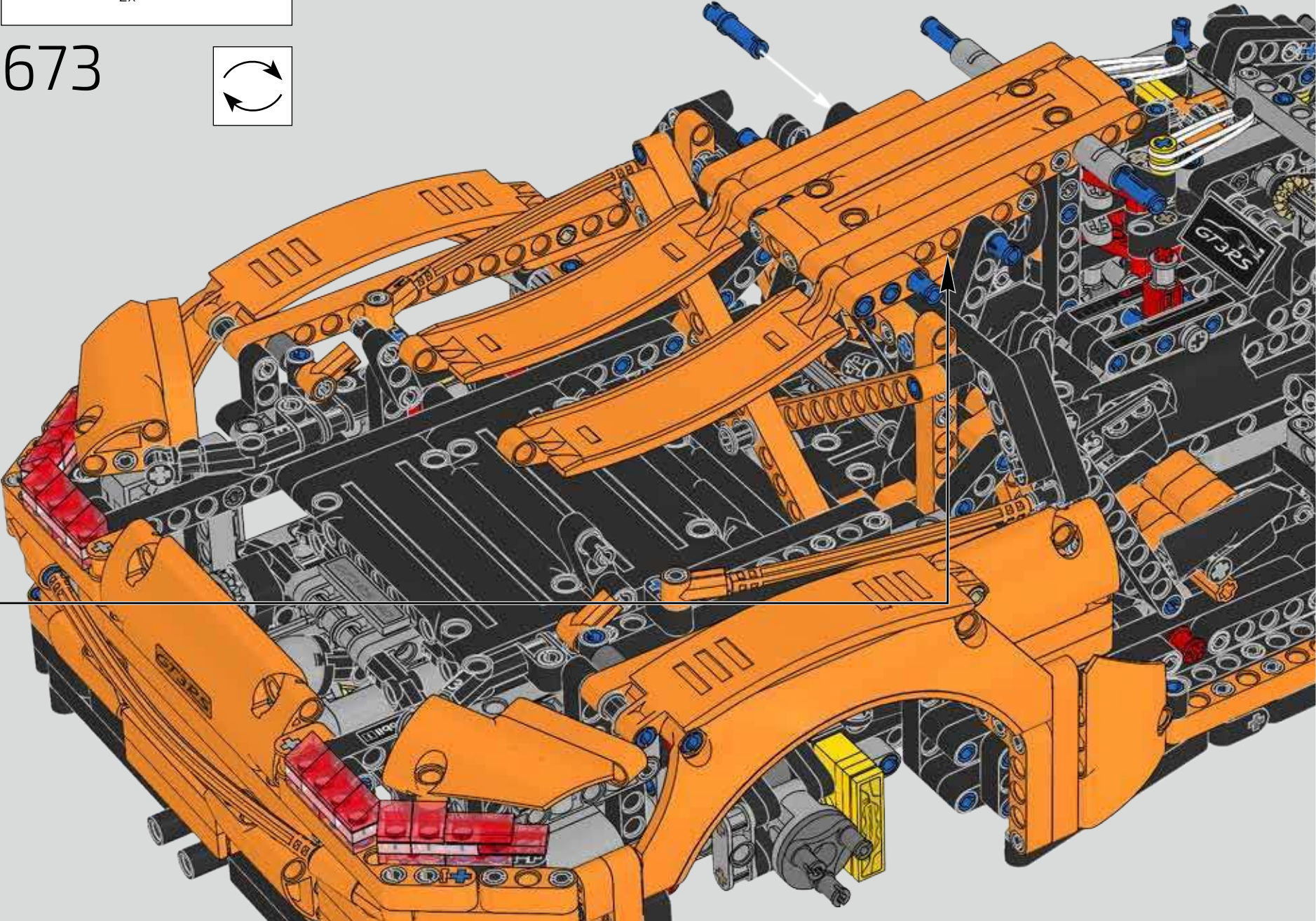
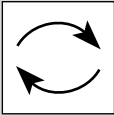



674

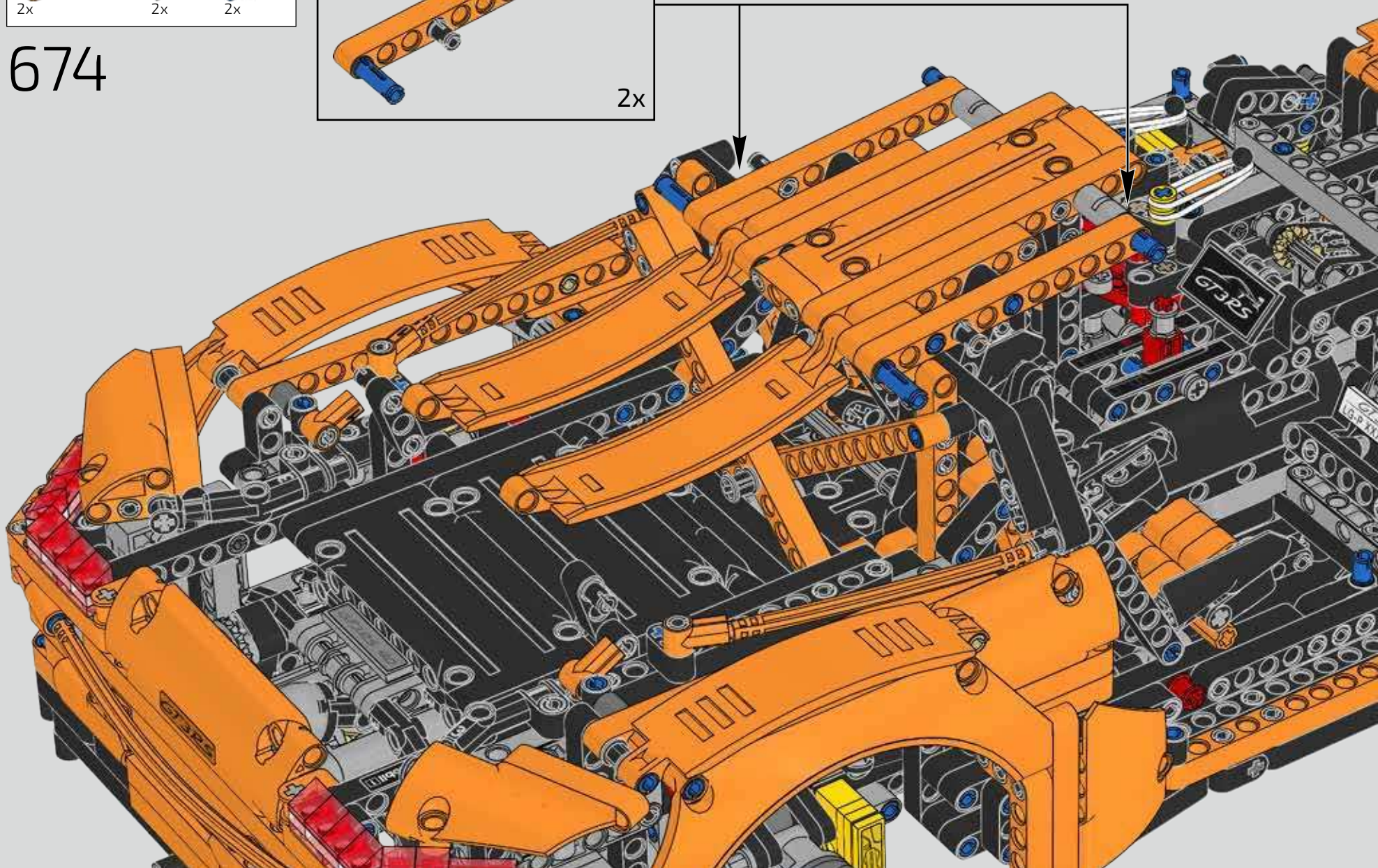
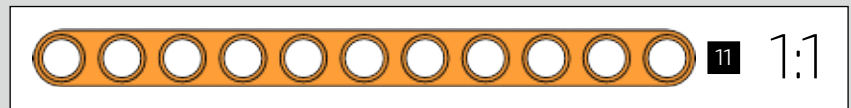
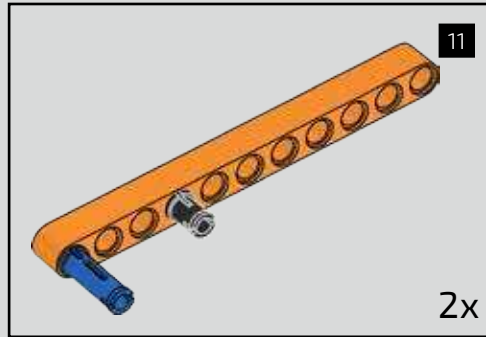

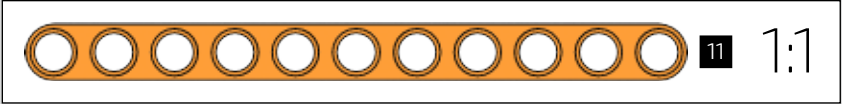
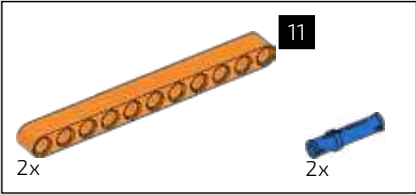

675

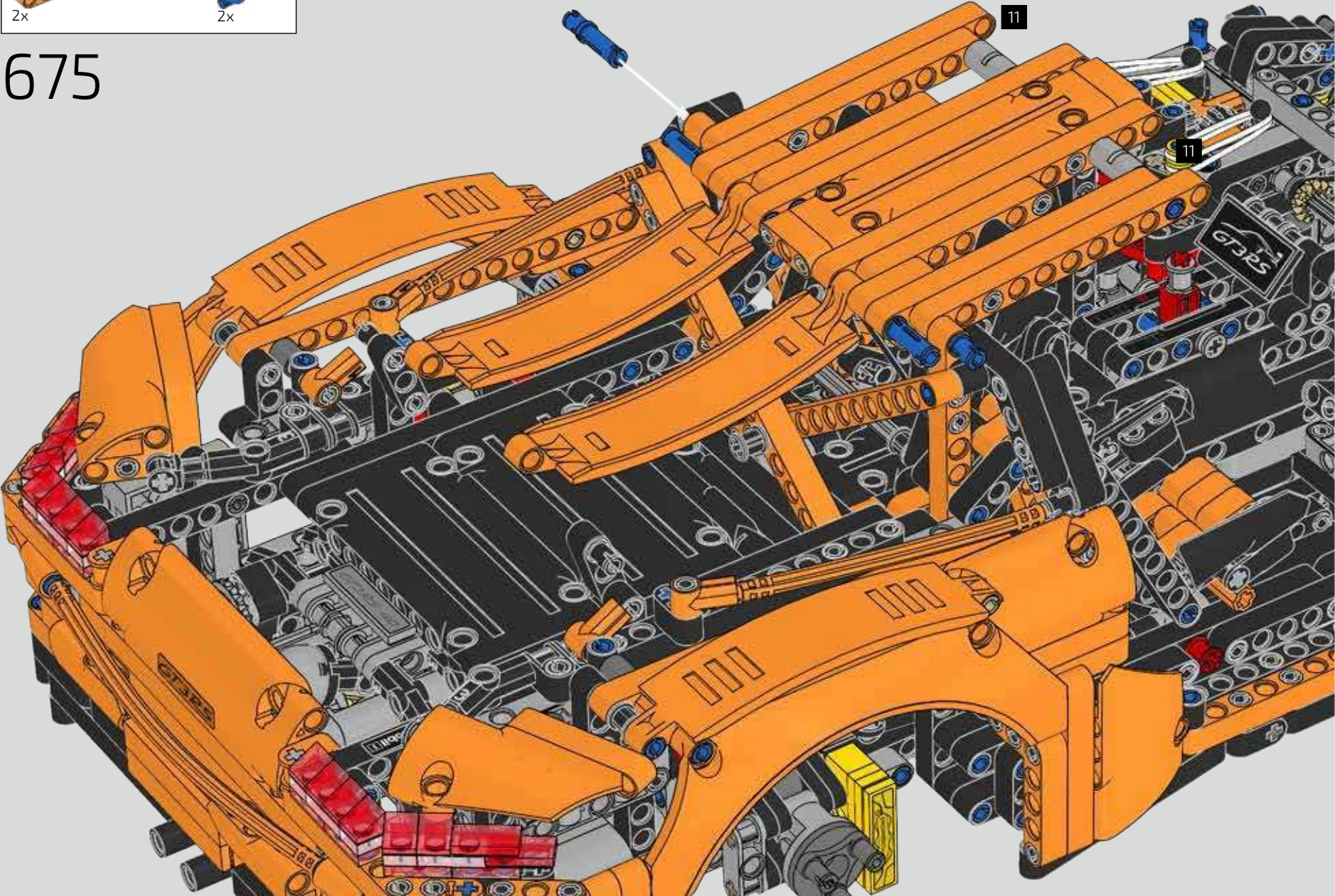



676

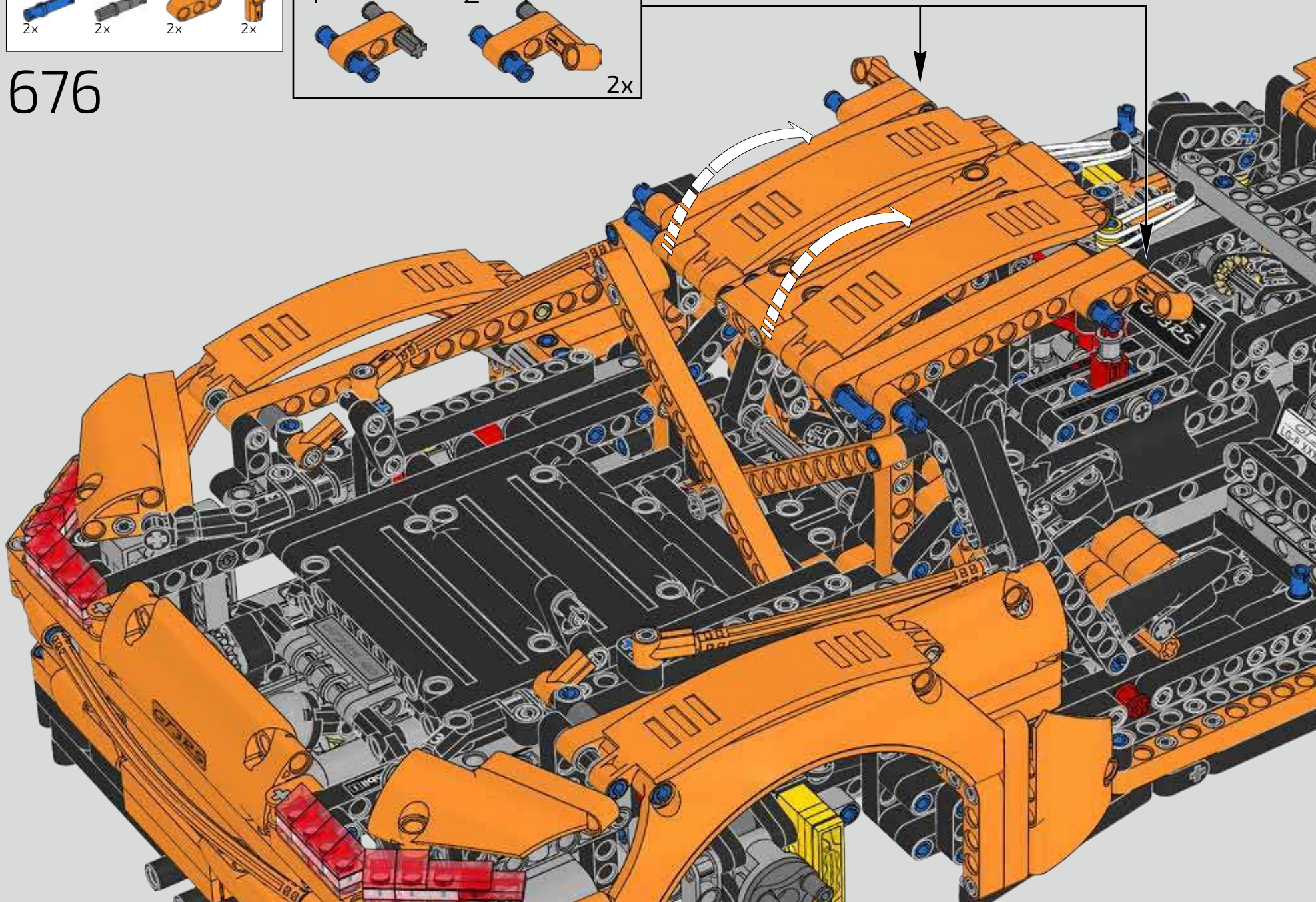
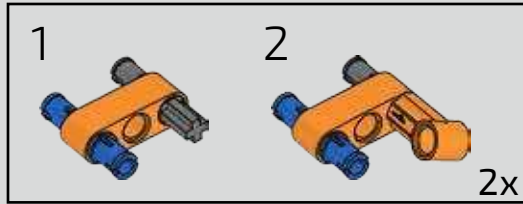

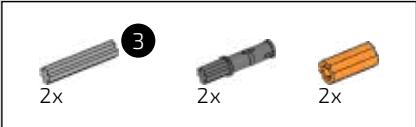

677

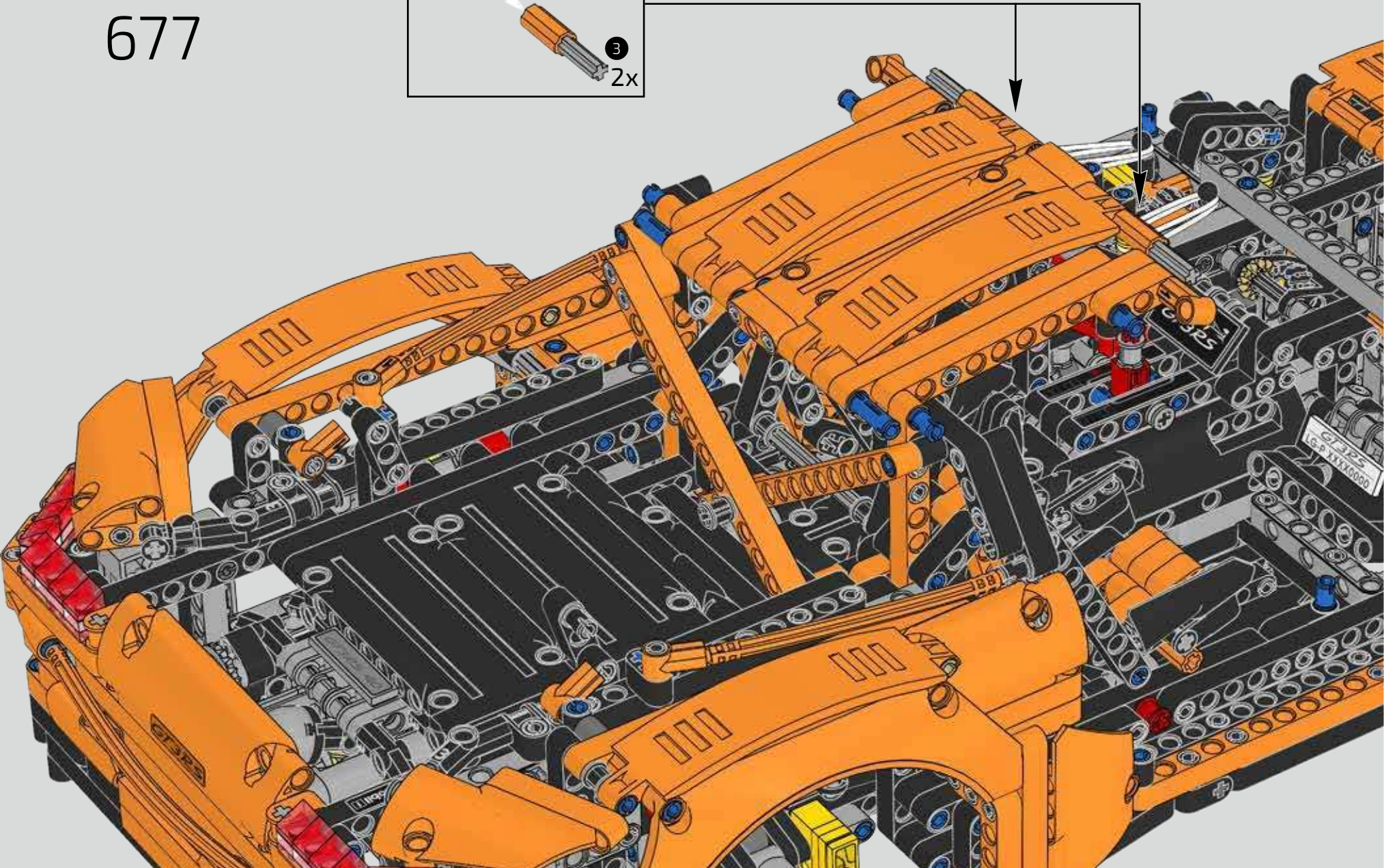
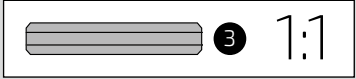
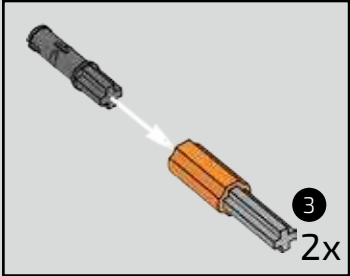

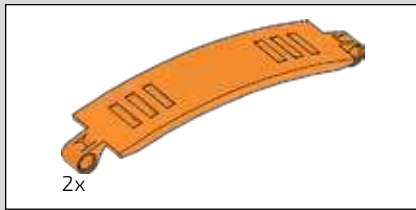

678

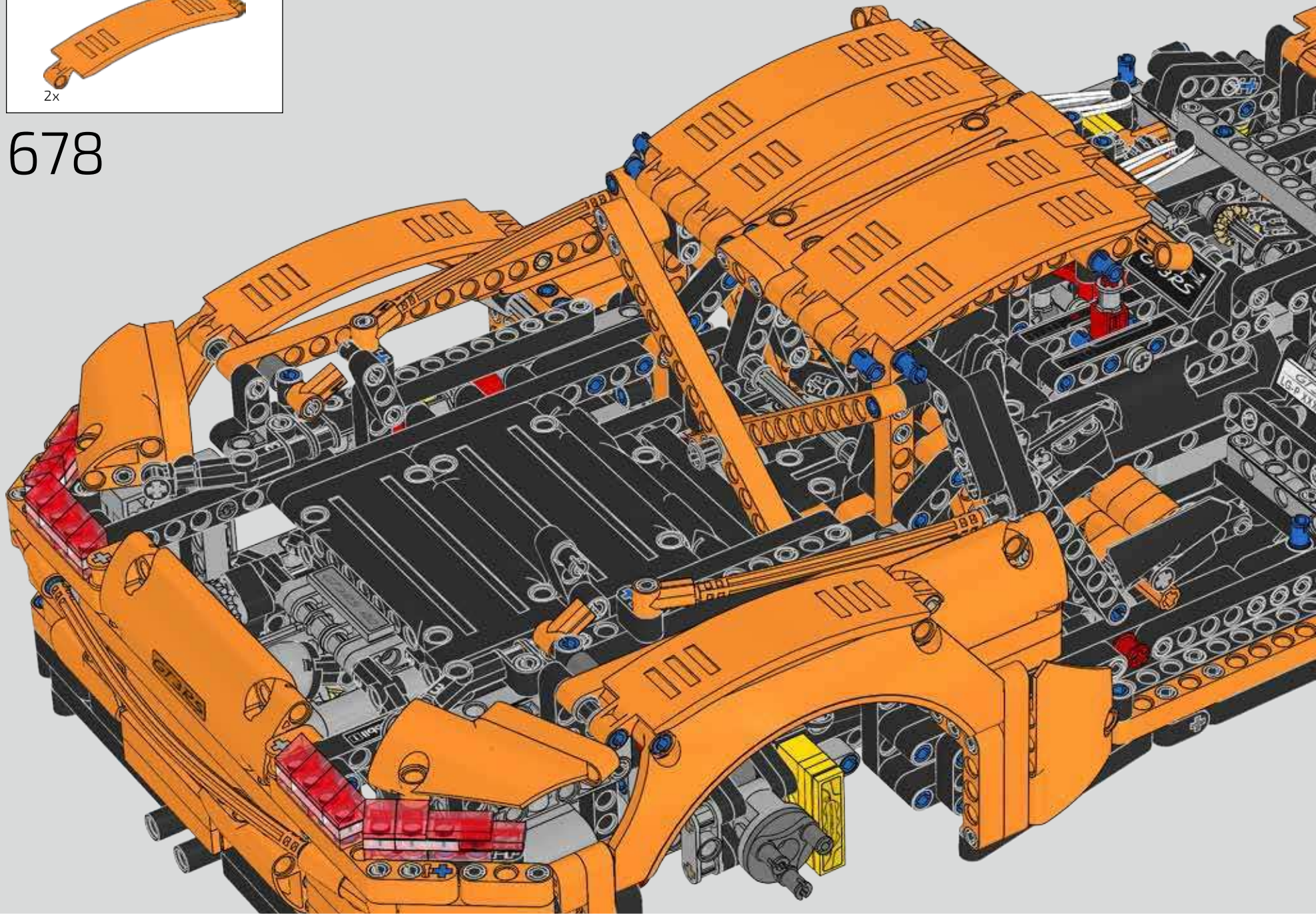

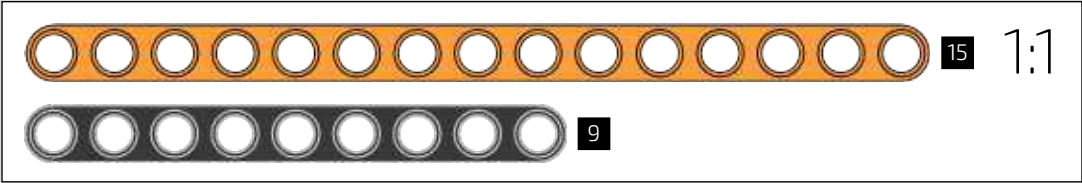
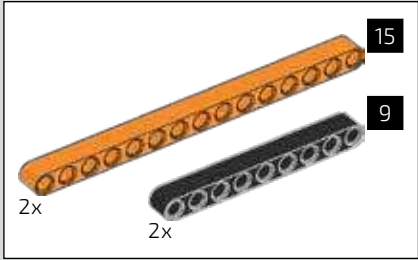

679

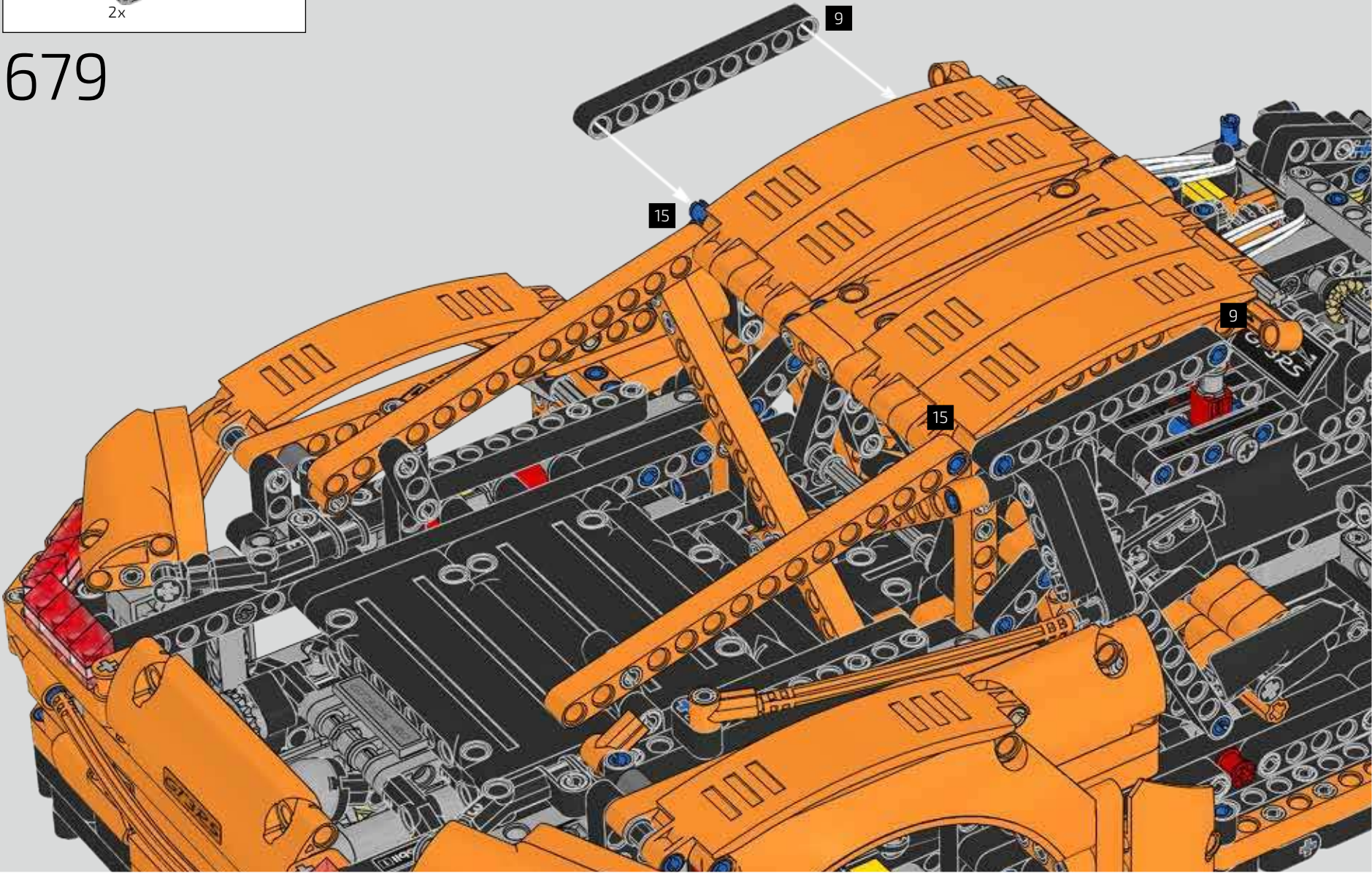



4

Now you build the front before adding the distinctive wheel arches with air outlets only found on the 911 GT3 RS. Next you add the massive, motorsport inspired, adjustable rear wing before finishing off your 911 GT3 RS by adding the doors and the exclusive wheels.

Nun werden die letzten Karosserieteile montiert. Zunächst werden die speziellen Leichtbaukotflügel mit ihren charakteristischen Lufteinlässen hinzugefügt, die nur der 911 GT3 RS besitzt. Danach wird der große einstellbare Heckflügel verbaut, der dem Fahrzeug den notwendigen Anpressdruck auf der Hinterachse verleiht und damit die Rennstreckenambitionen des 911 GT3 RS unterstreicht. Zum Schluss wird das Fahrzeug noch mit den Türen und den GT-spezifischen Rädern ausgestattet.



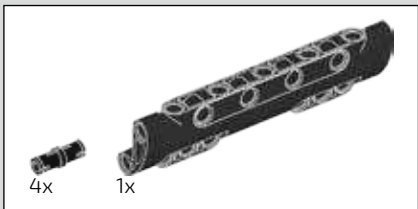
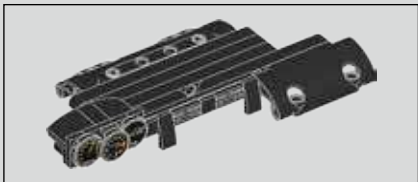

680

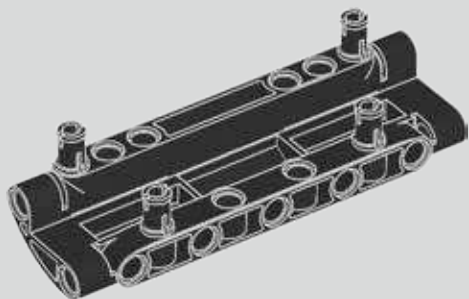

681

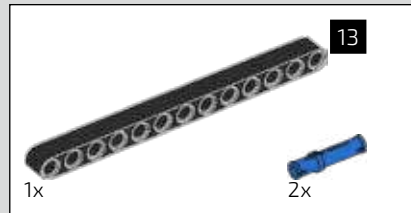
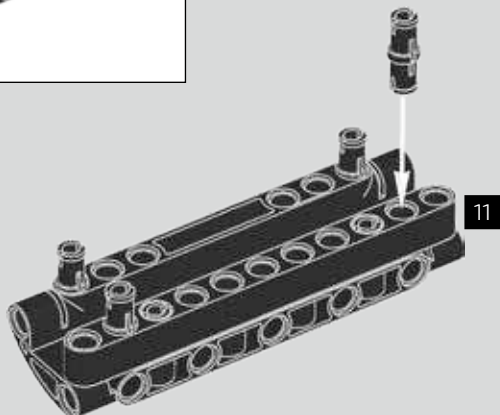

682

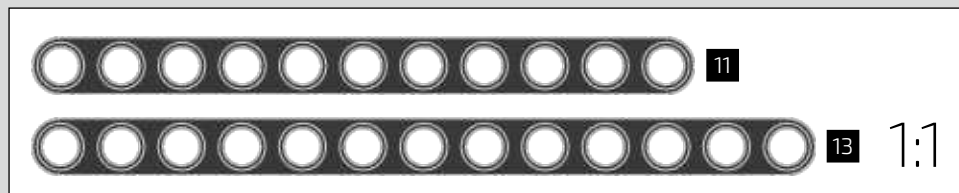
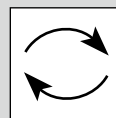

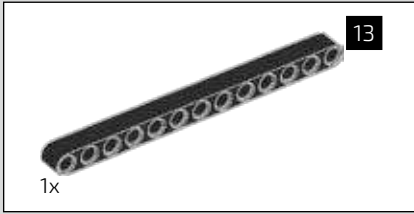

683



684

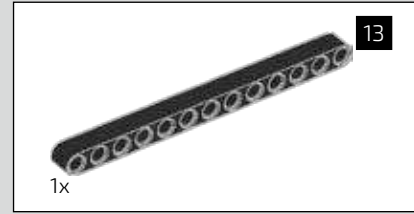
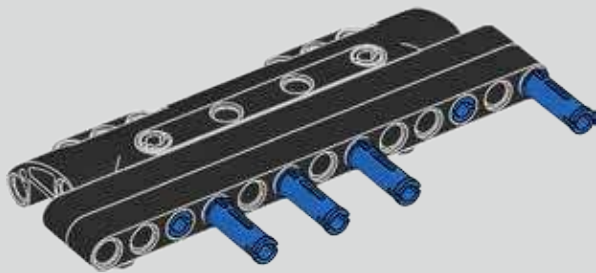

685

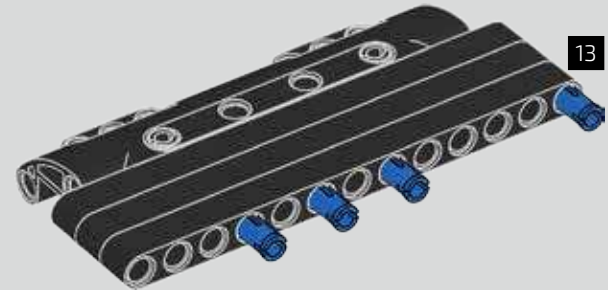



2x

9

686



9

9

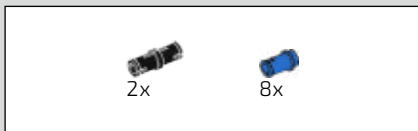

2x

8x

687

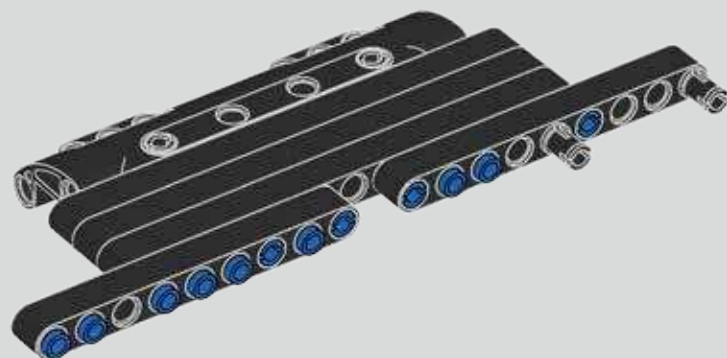

1x

688

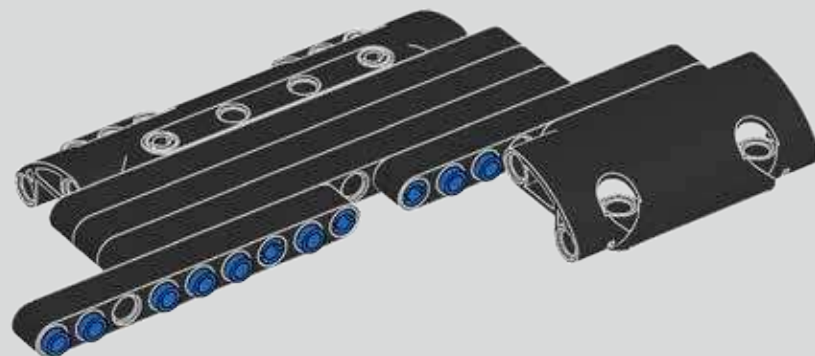

9

1:1

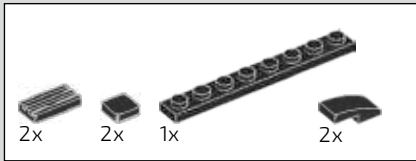

689

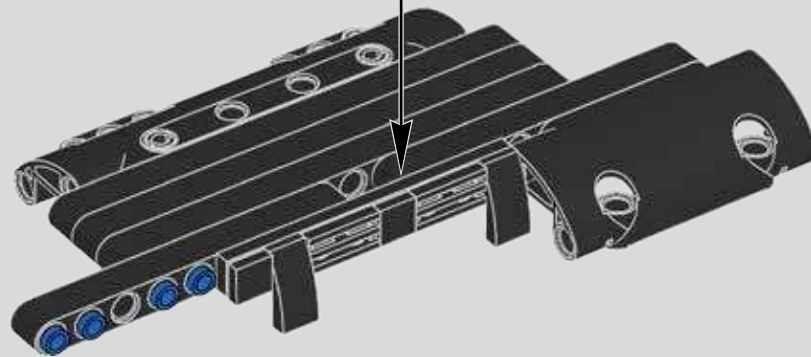
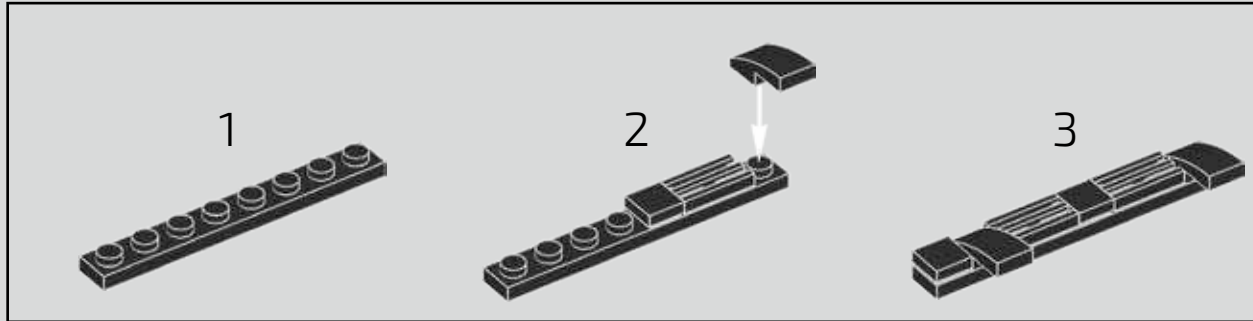

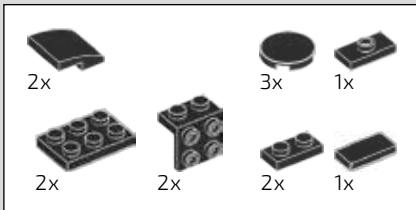

690

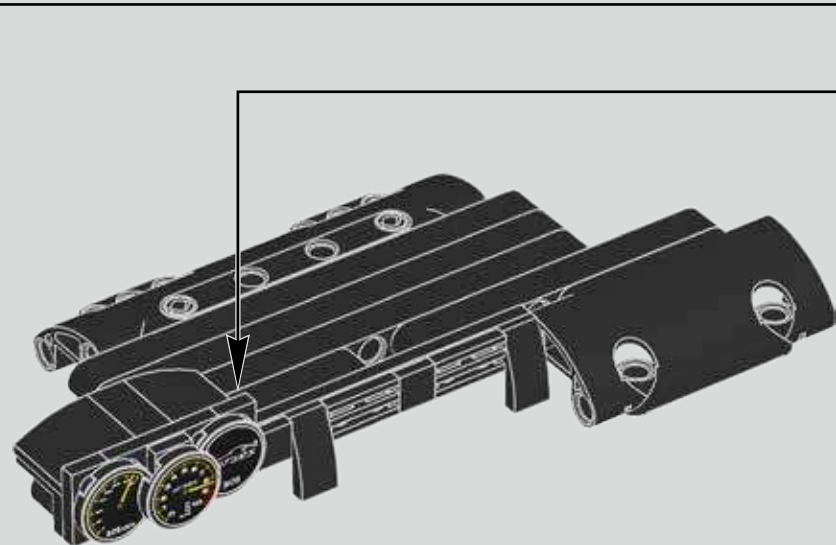
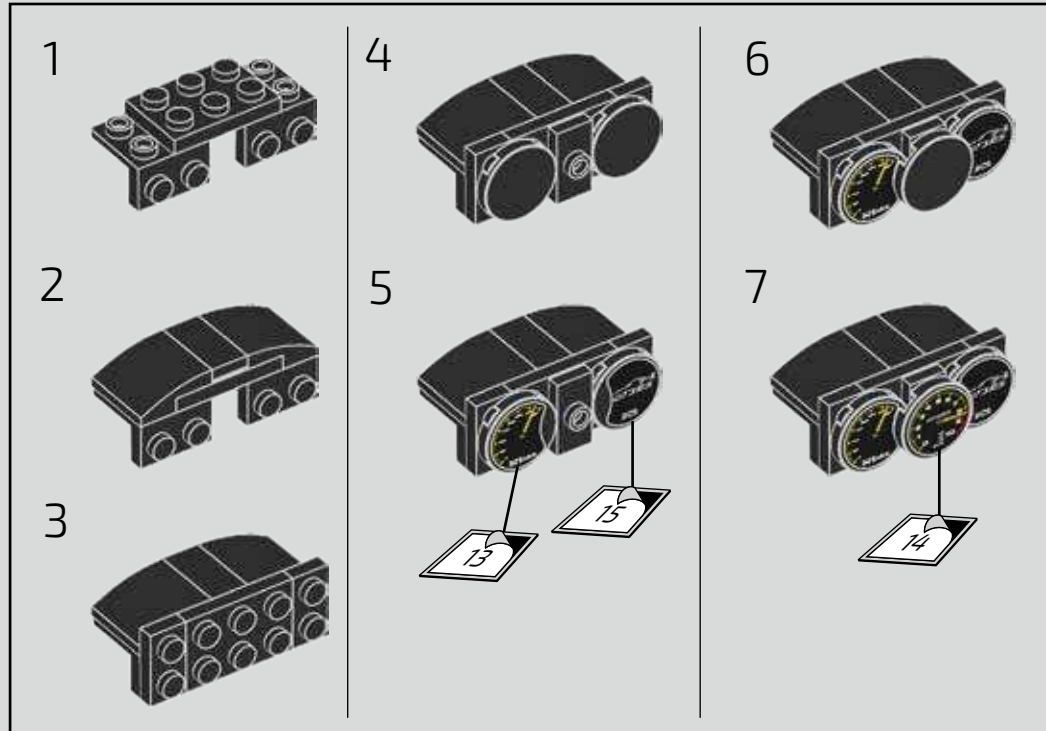

691

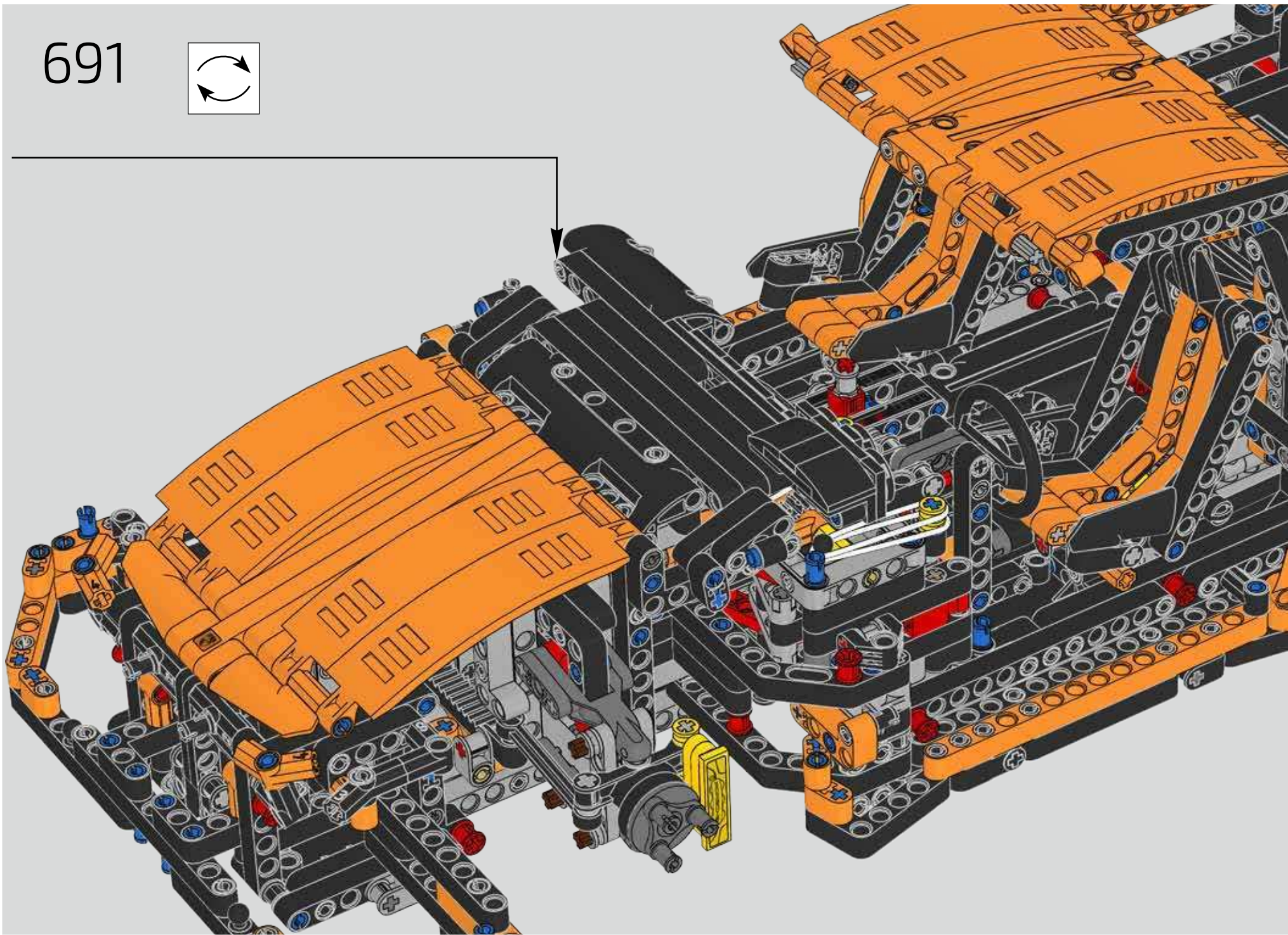
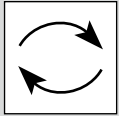

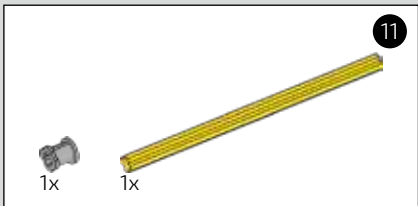
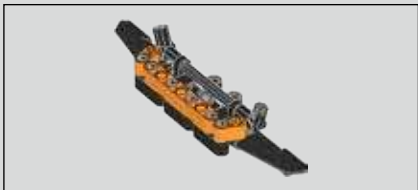

692



693

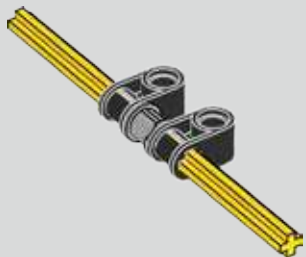

694

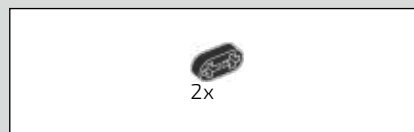

695

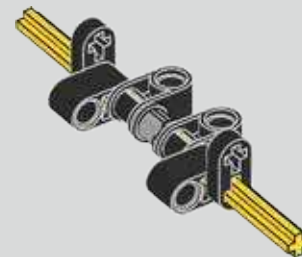



696

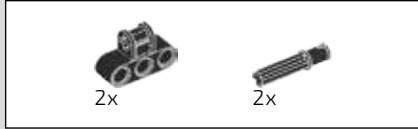
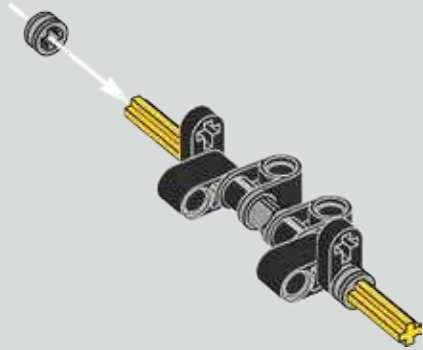

697

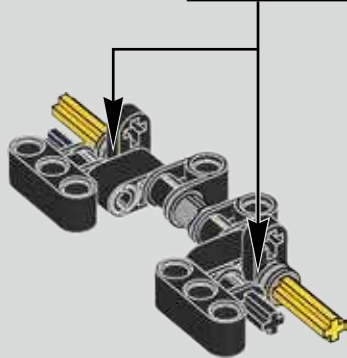
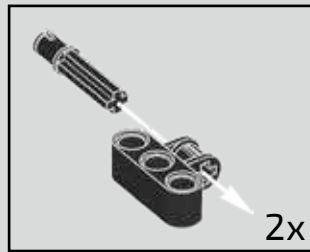

698

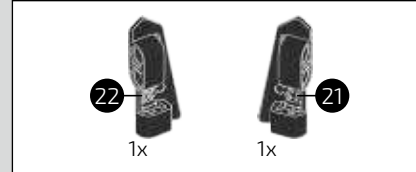
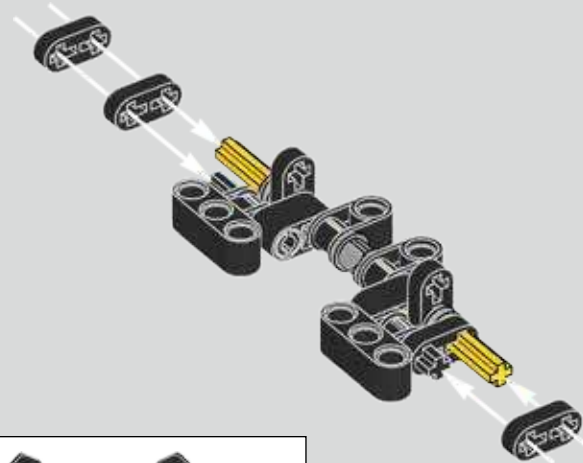

699

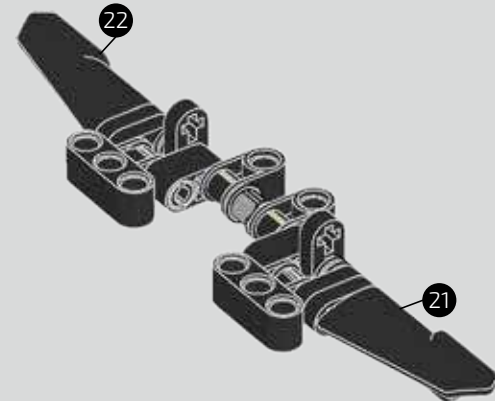

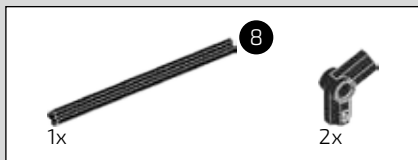

700

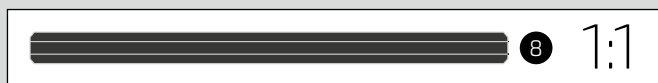
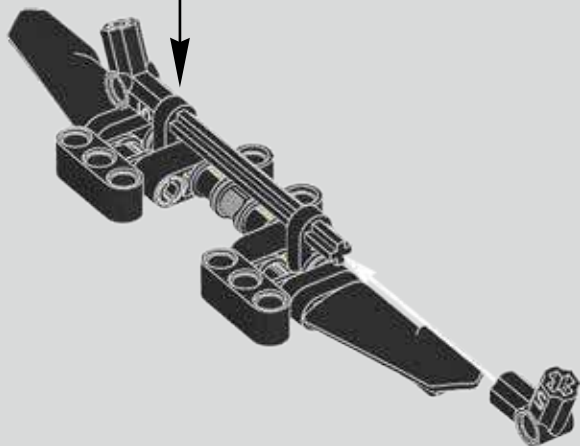
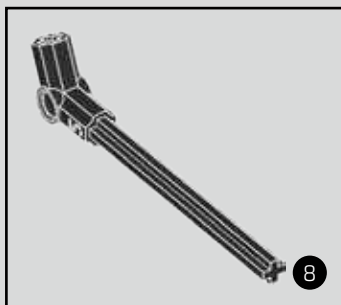

701

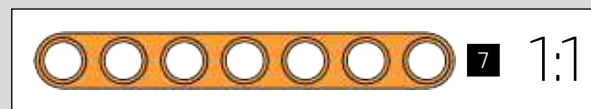
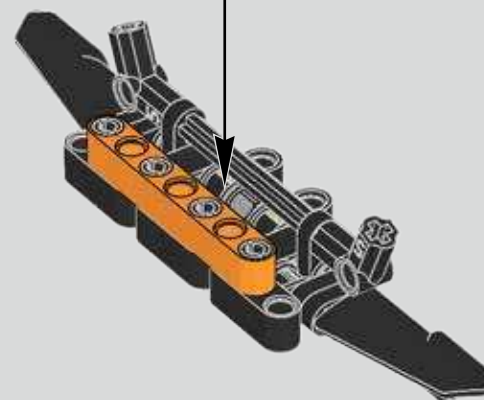
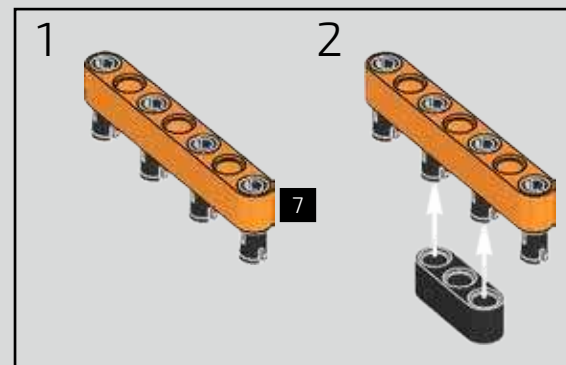



702

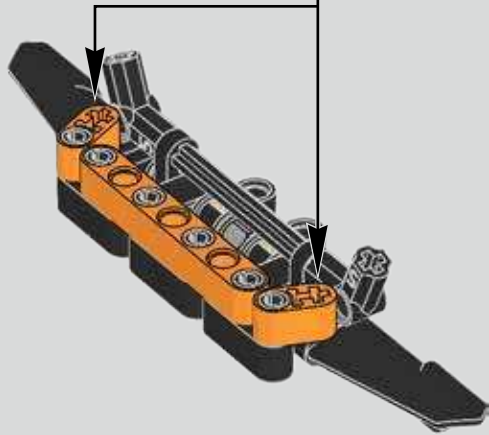

703

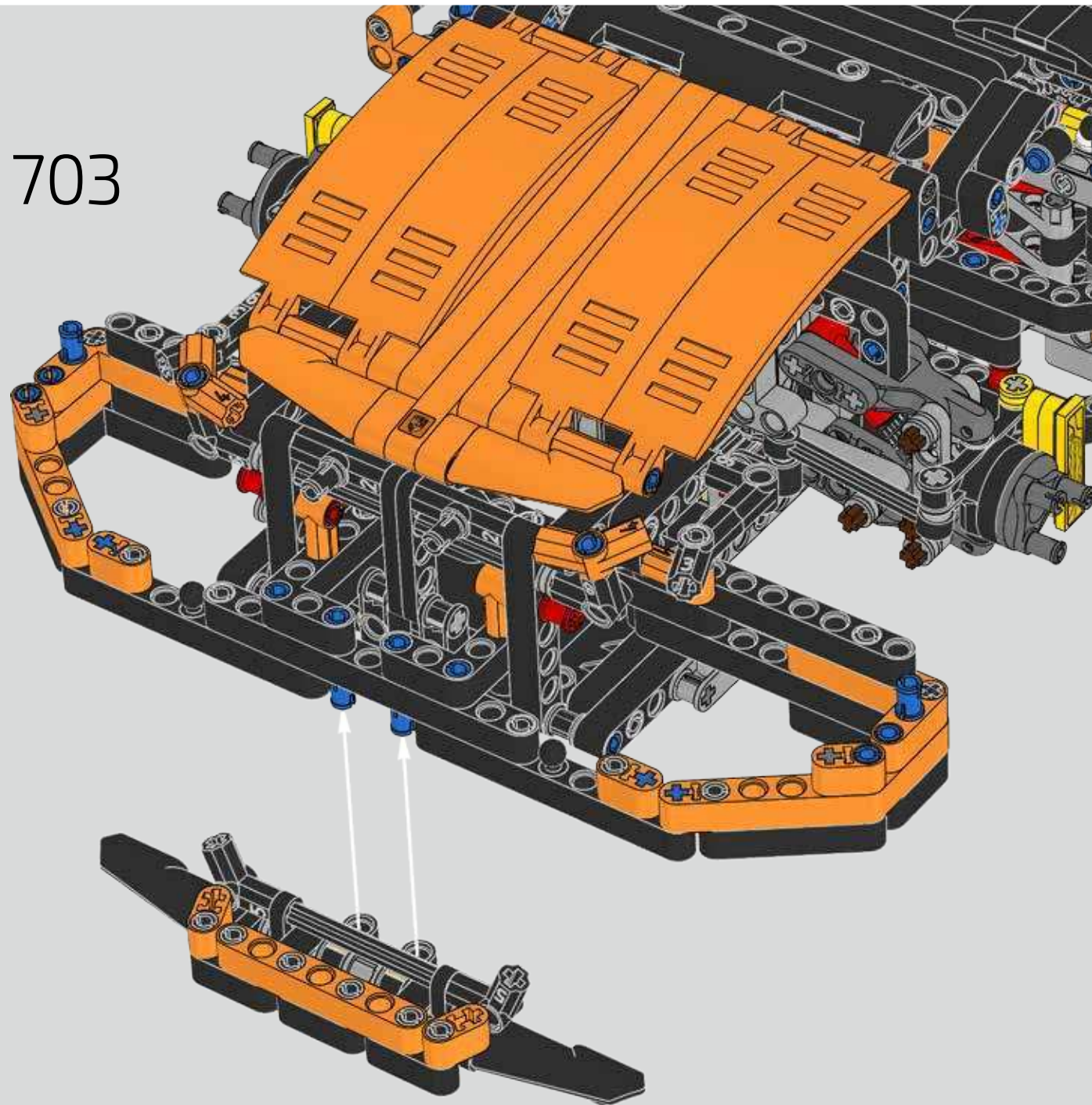

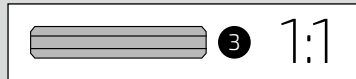
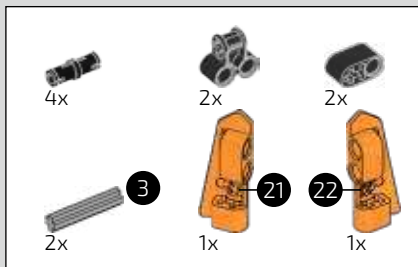

704

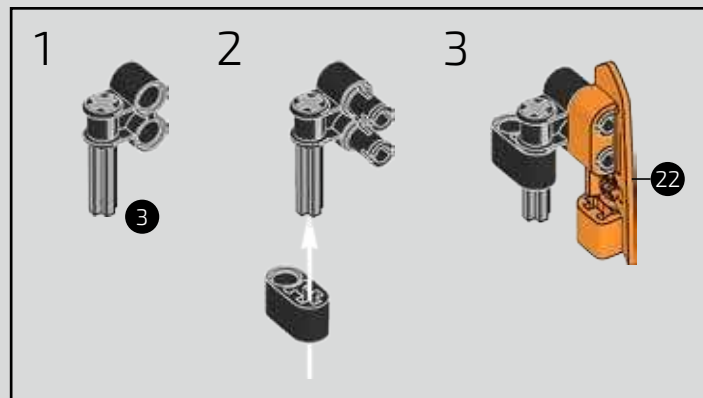
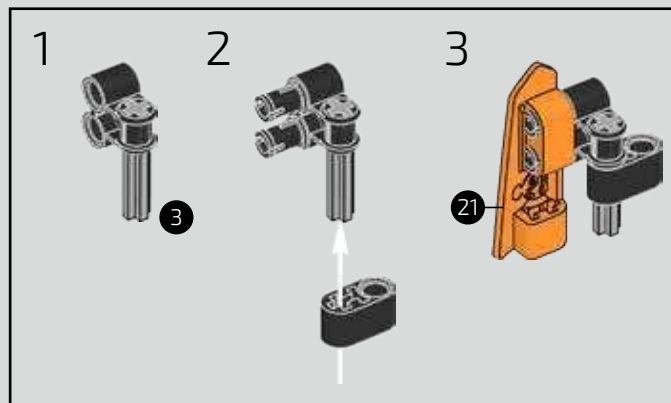

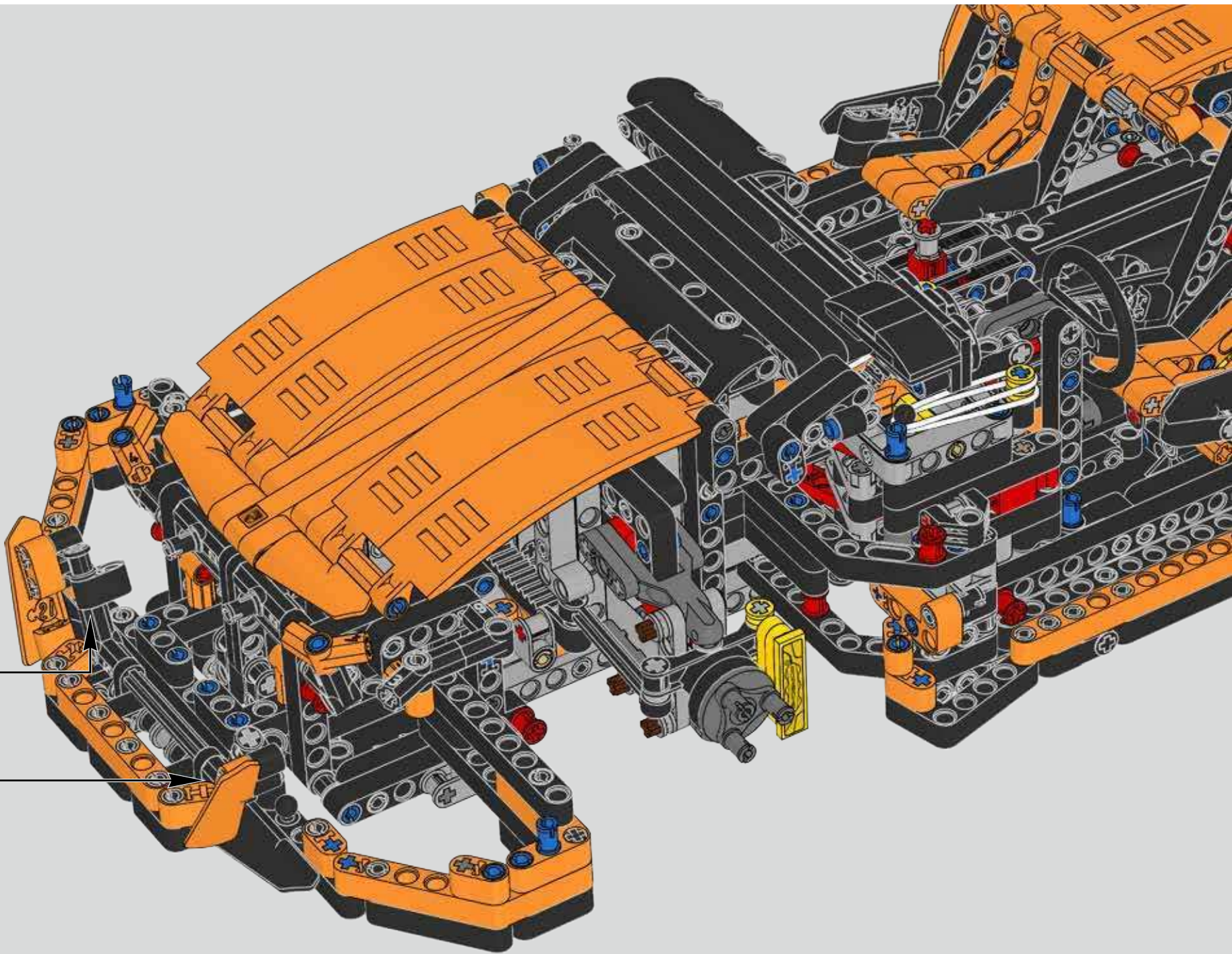

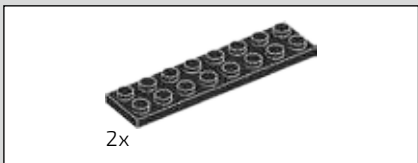
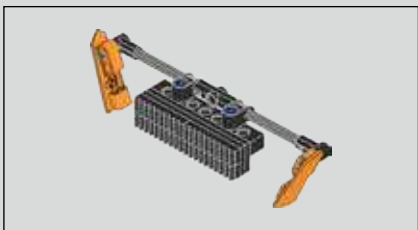

2x

705

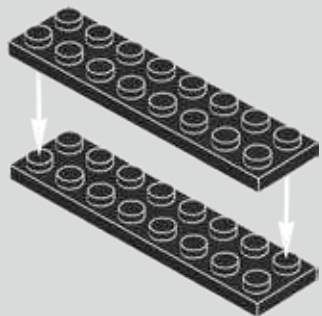

4x

706

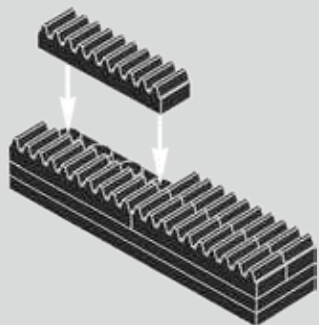

1x

707

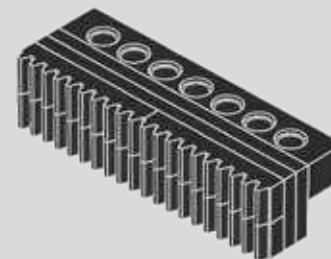
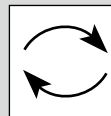

2x

708

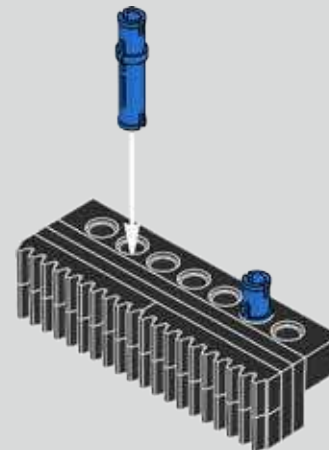

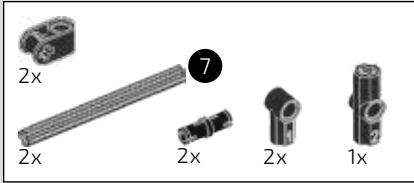

709

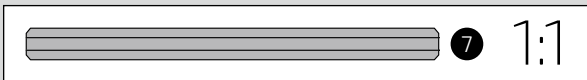
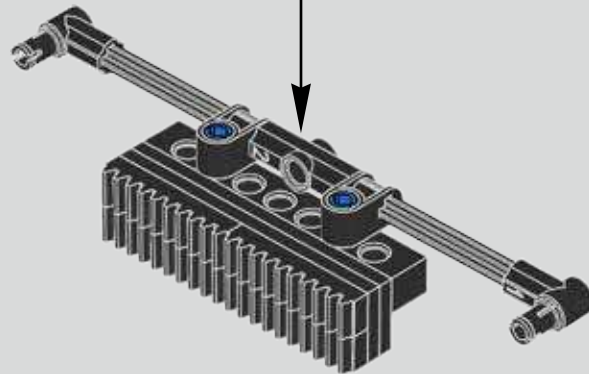
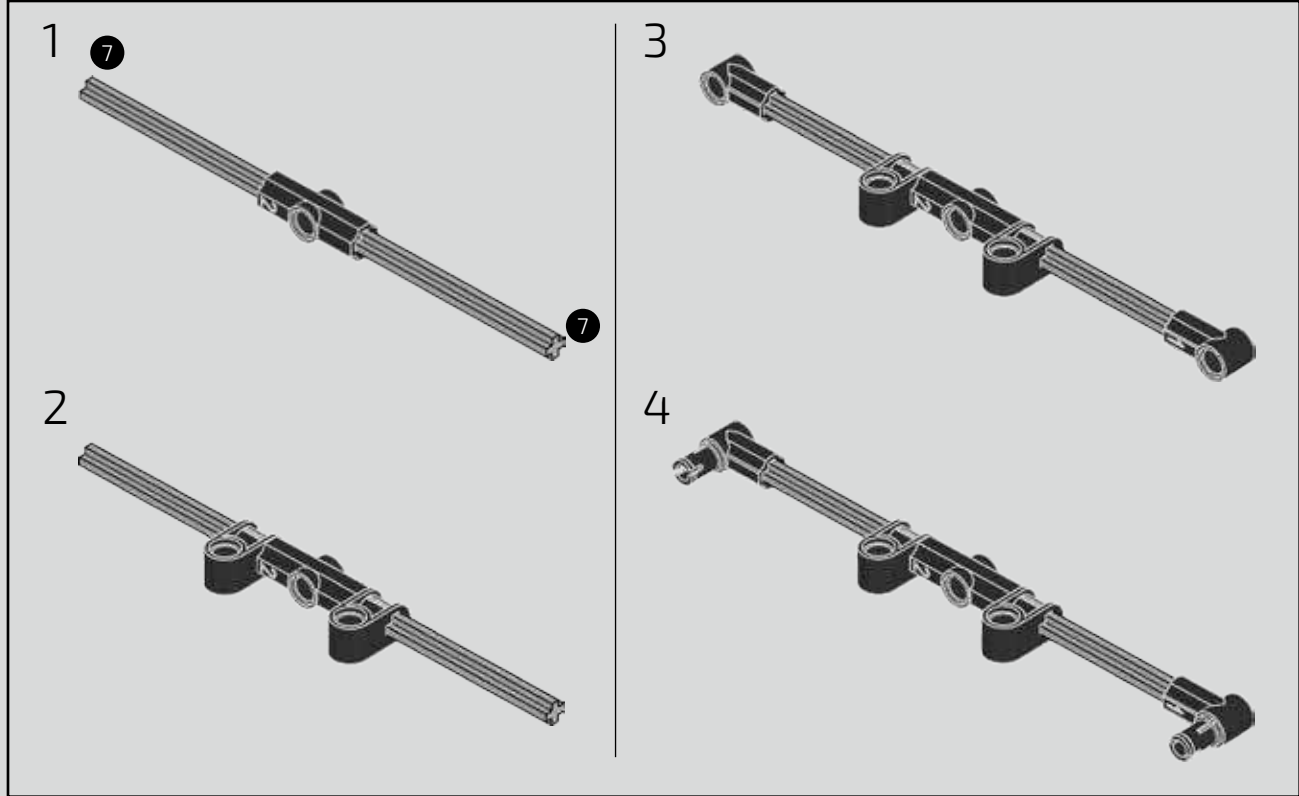

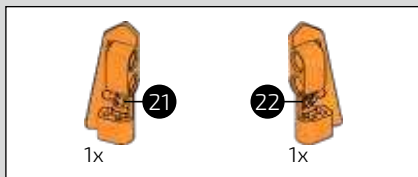

710

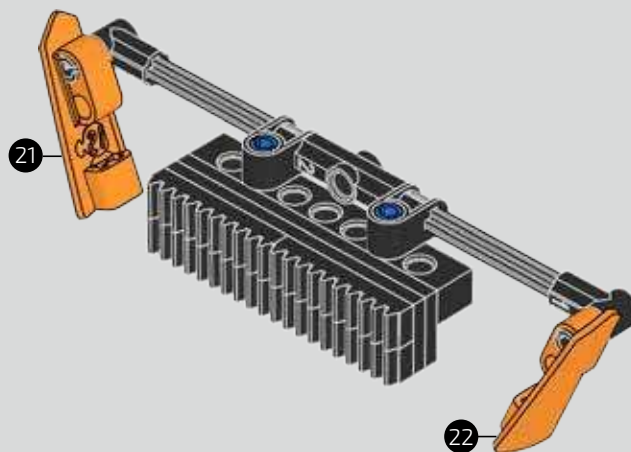

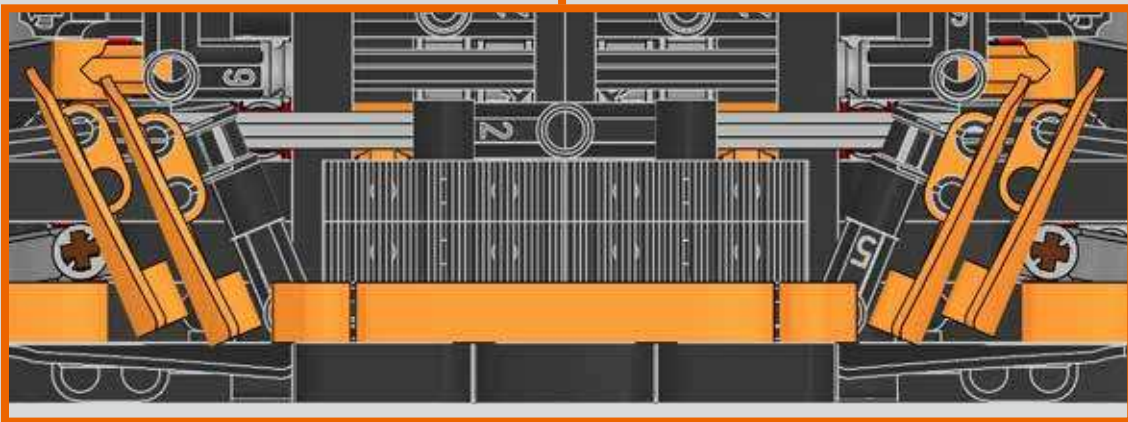
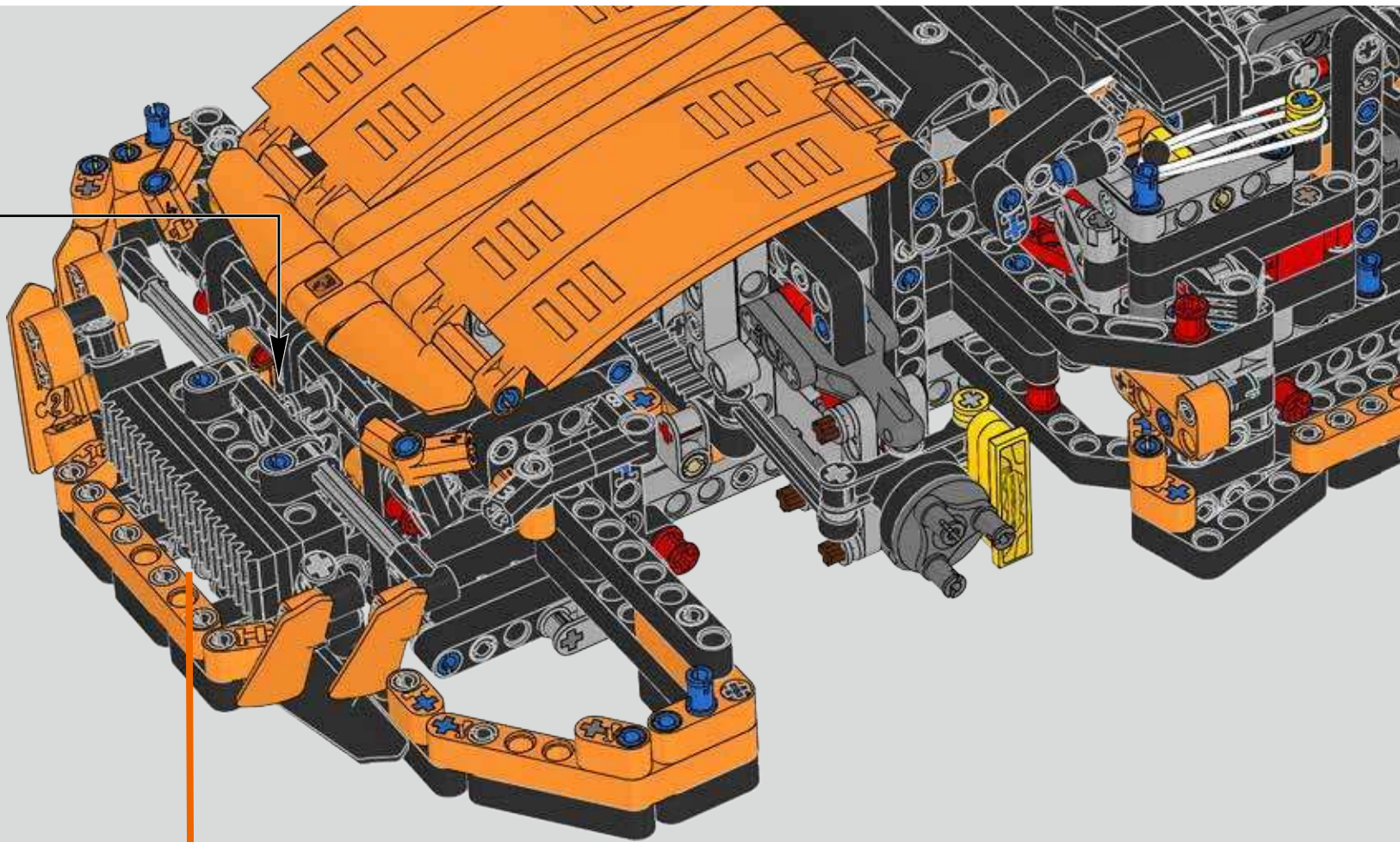

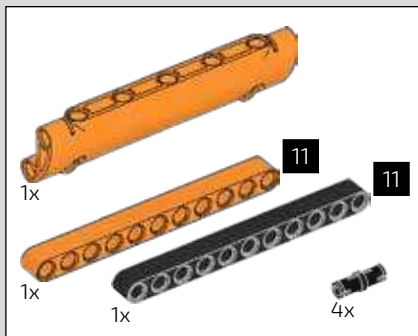

711

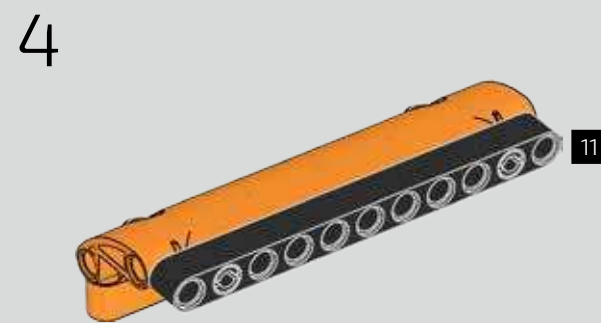
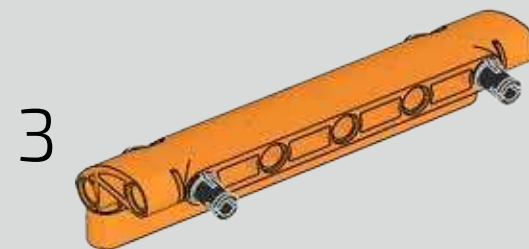
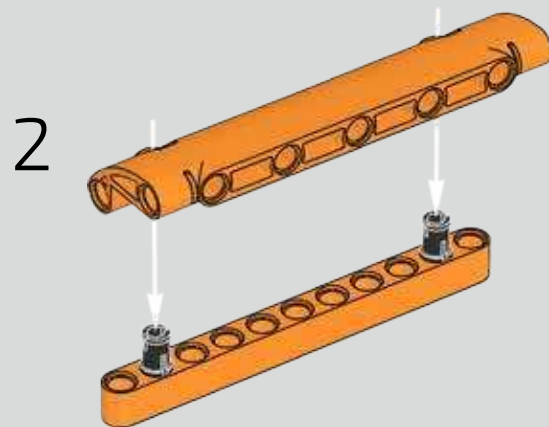
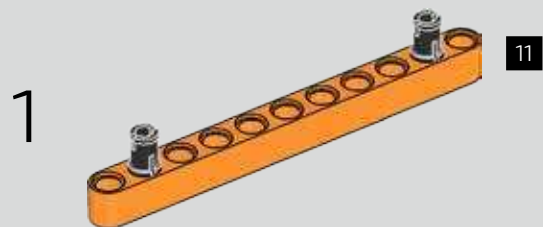
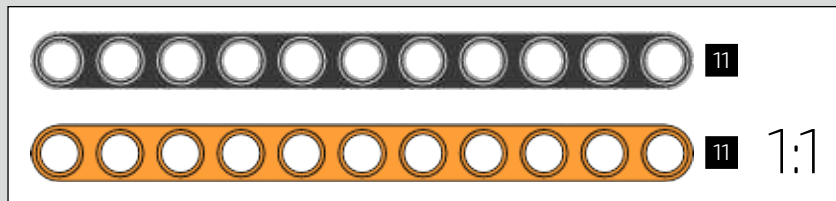

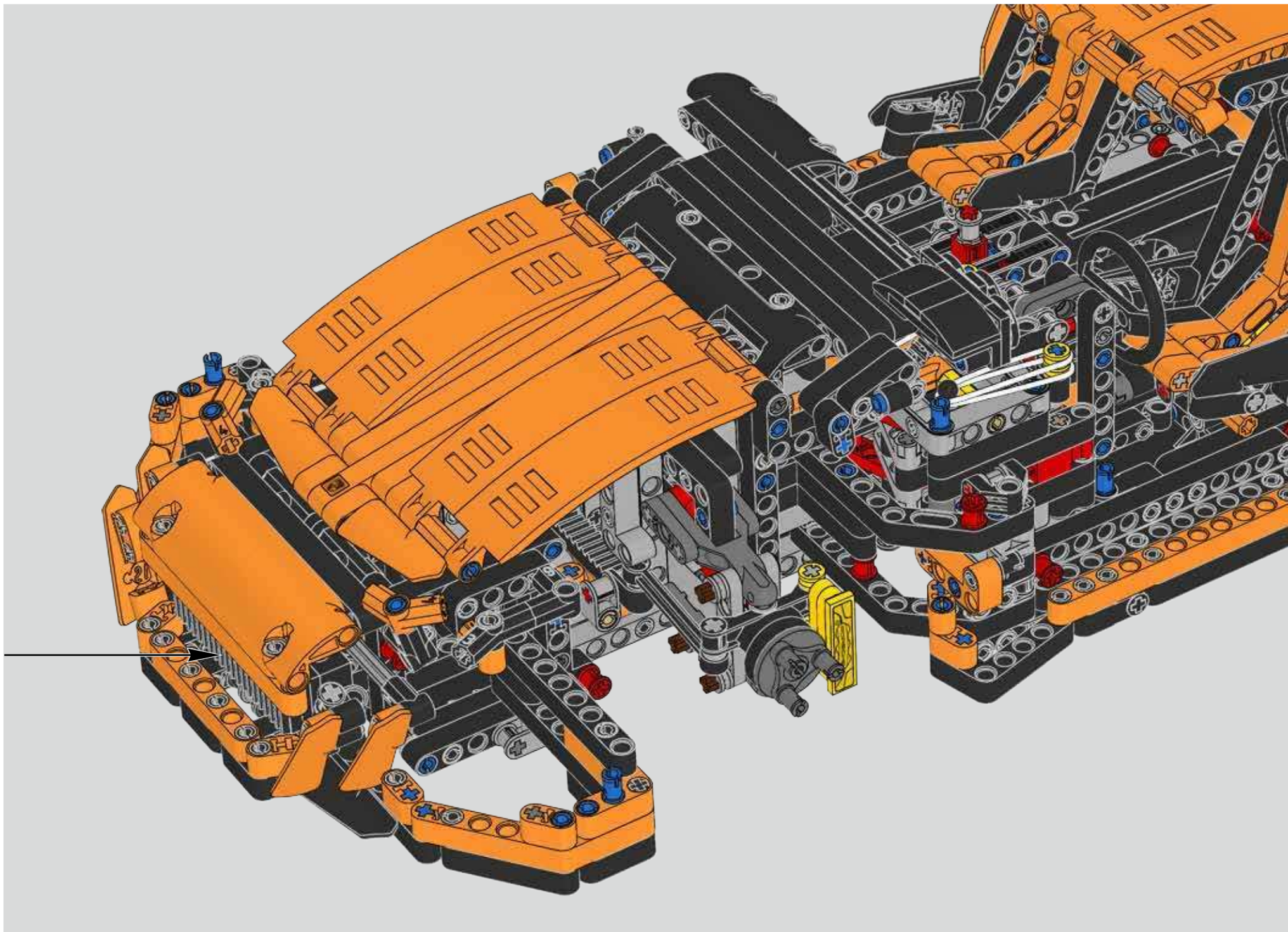

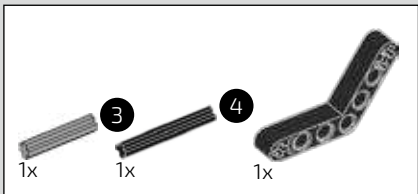

712

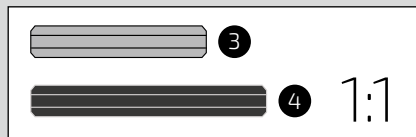
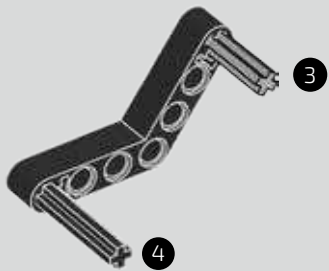

713

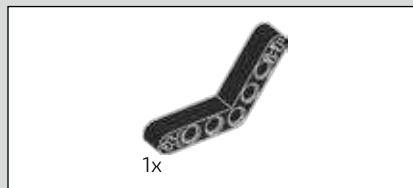
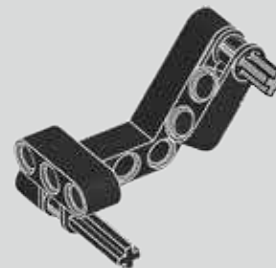

714



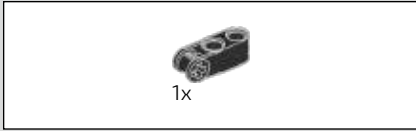

715



716

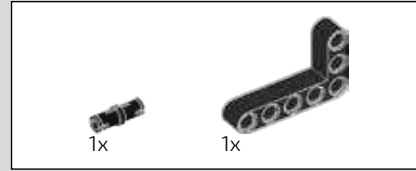
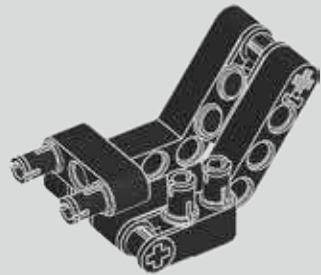

717

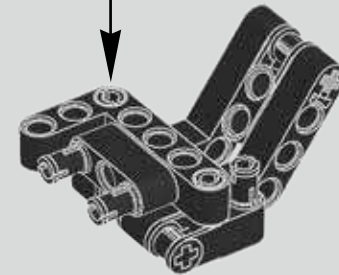

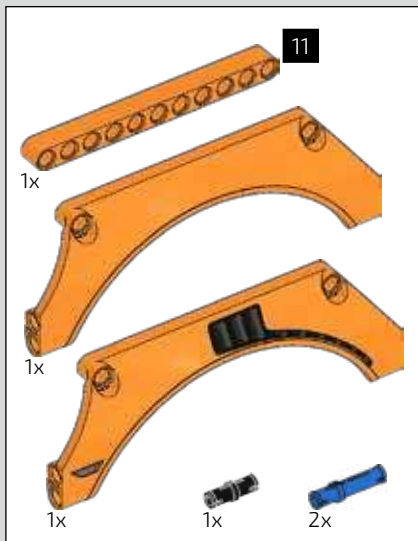

718

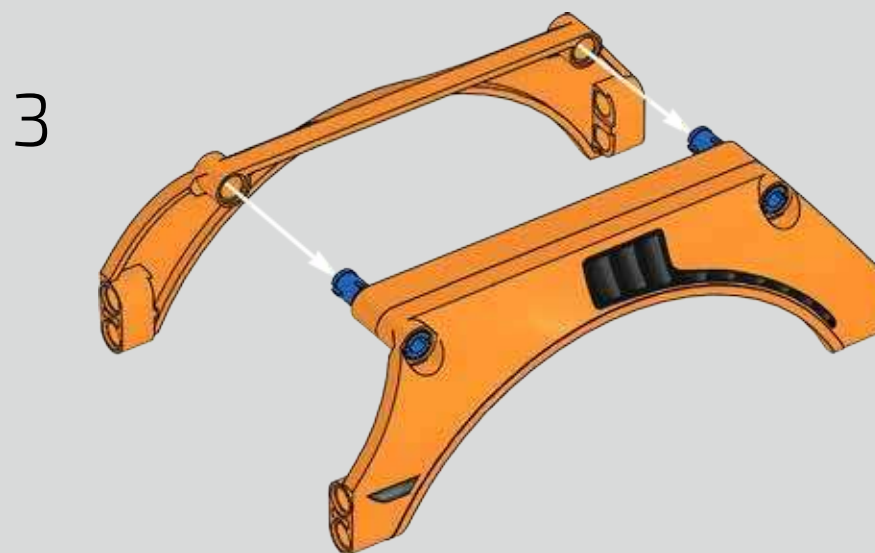
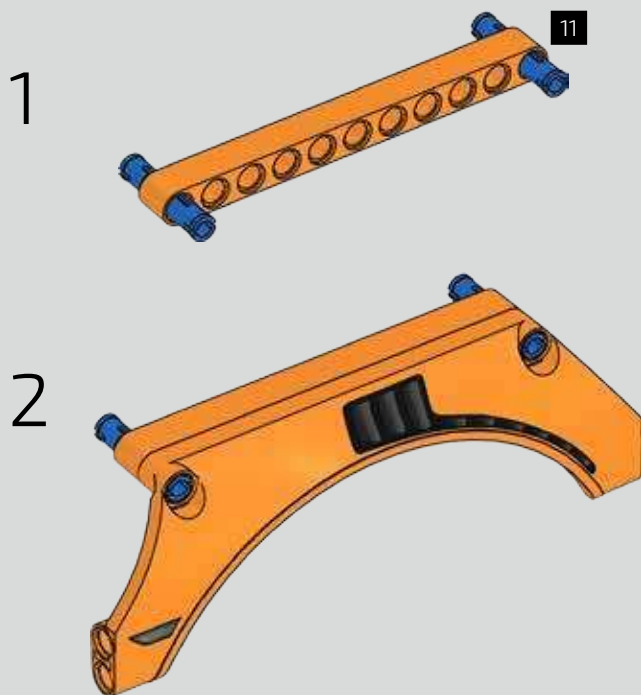

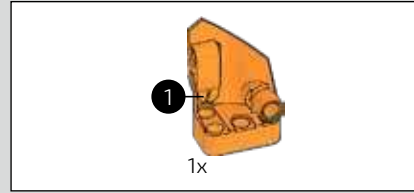
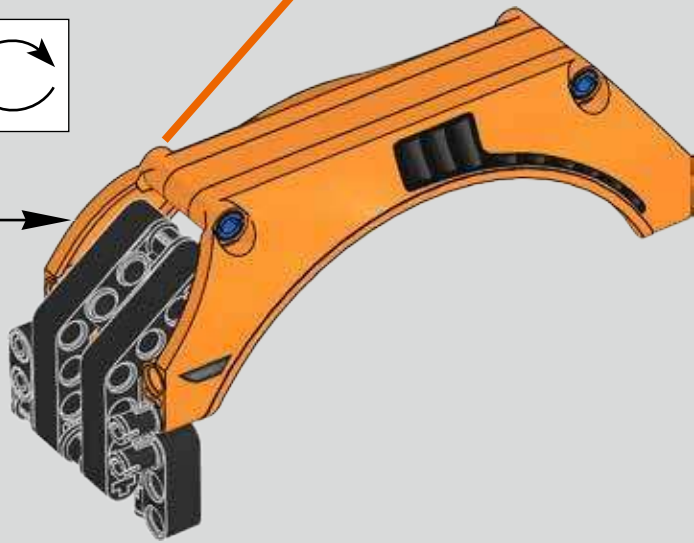
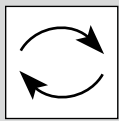
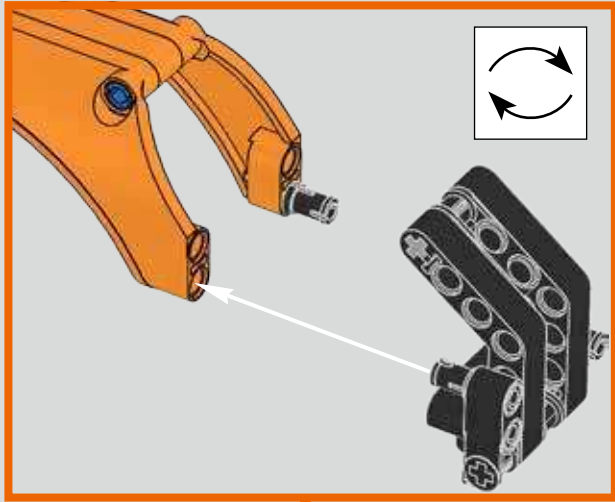

719

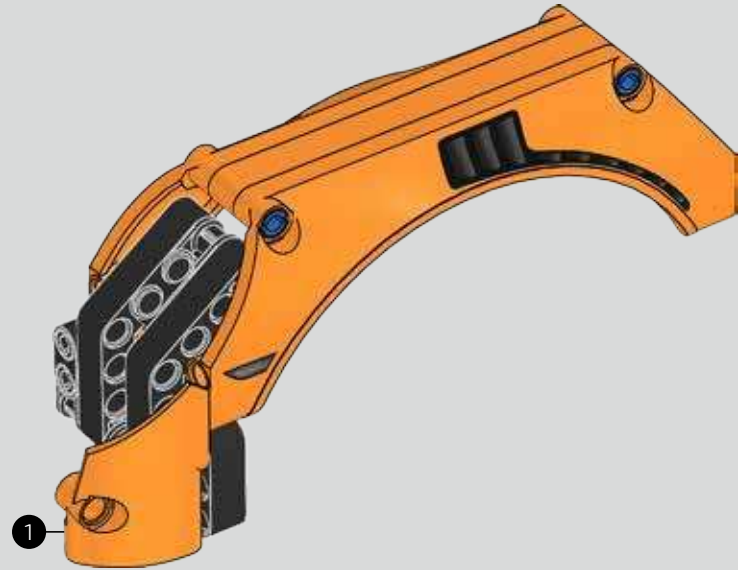

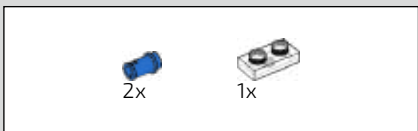

720

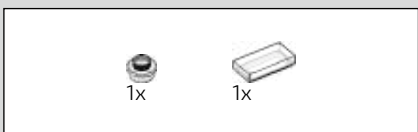
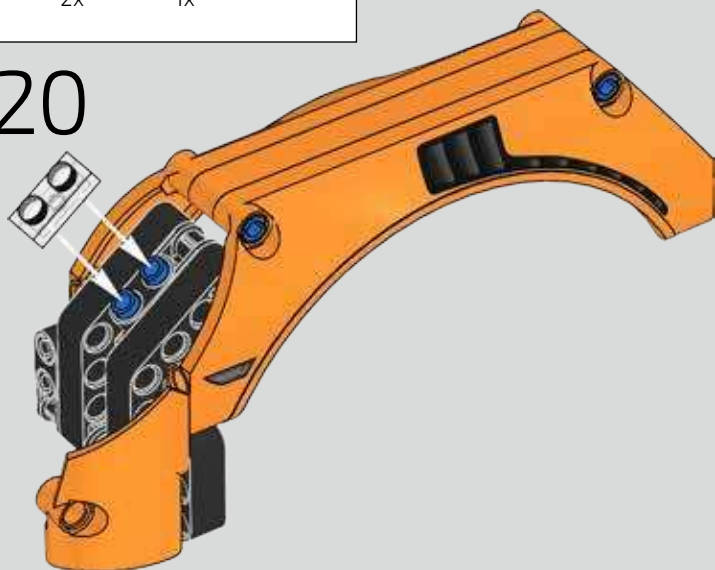

721

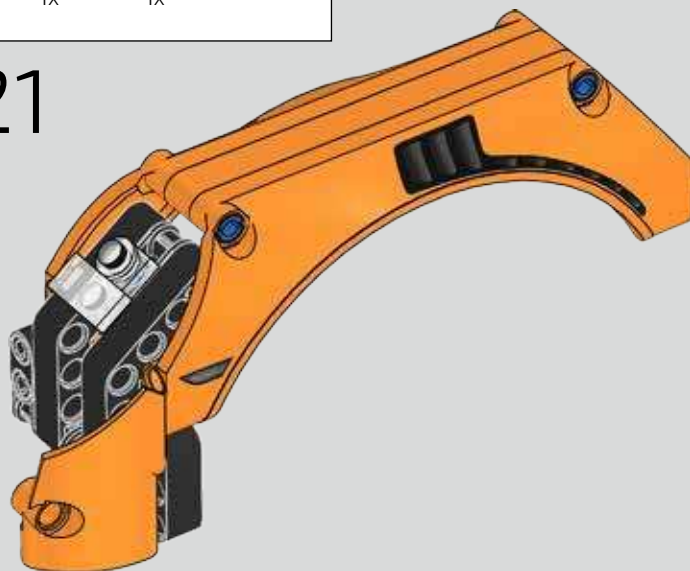

722

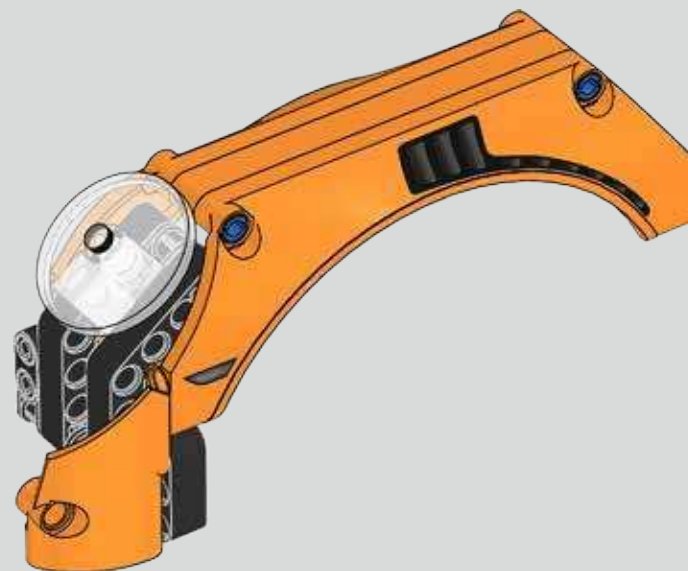

723

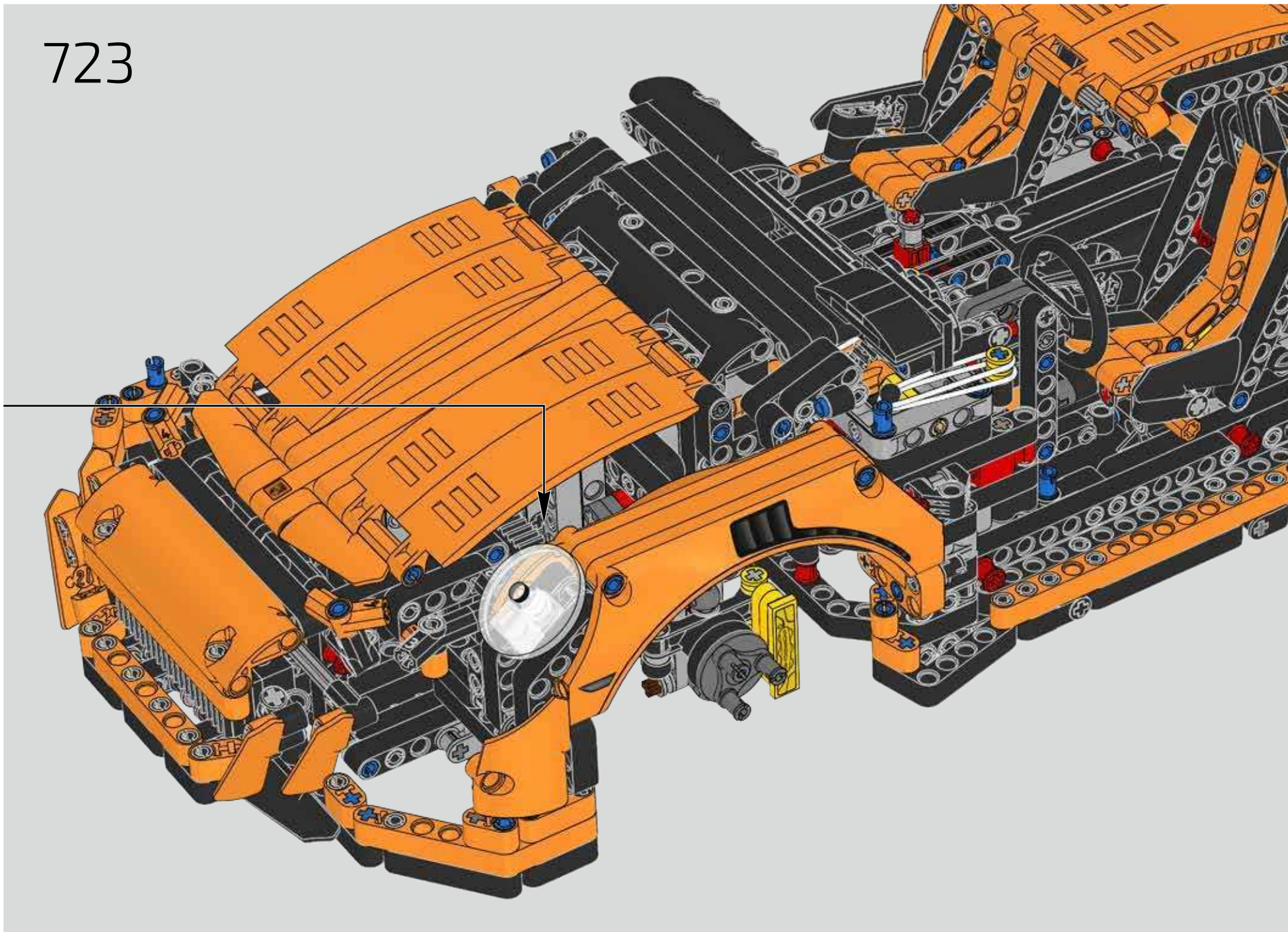

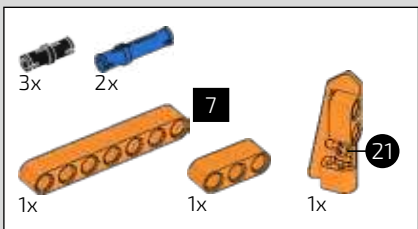

724

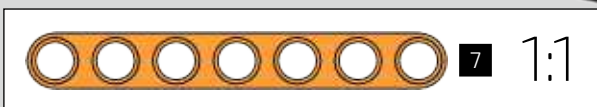
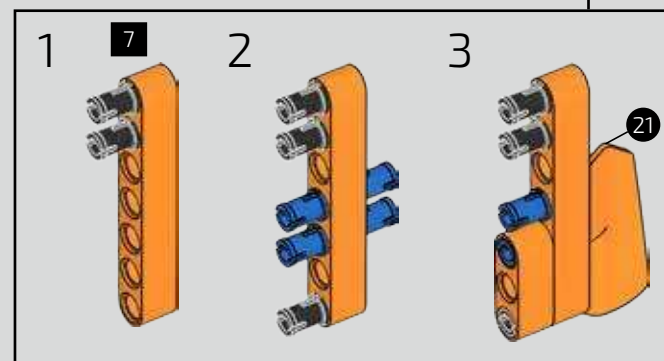
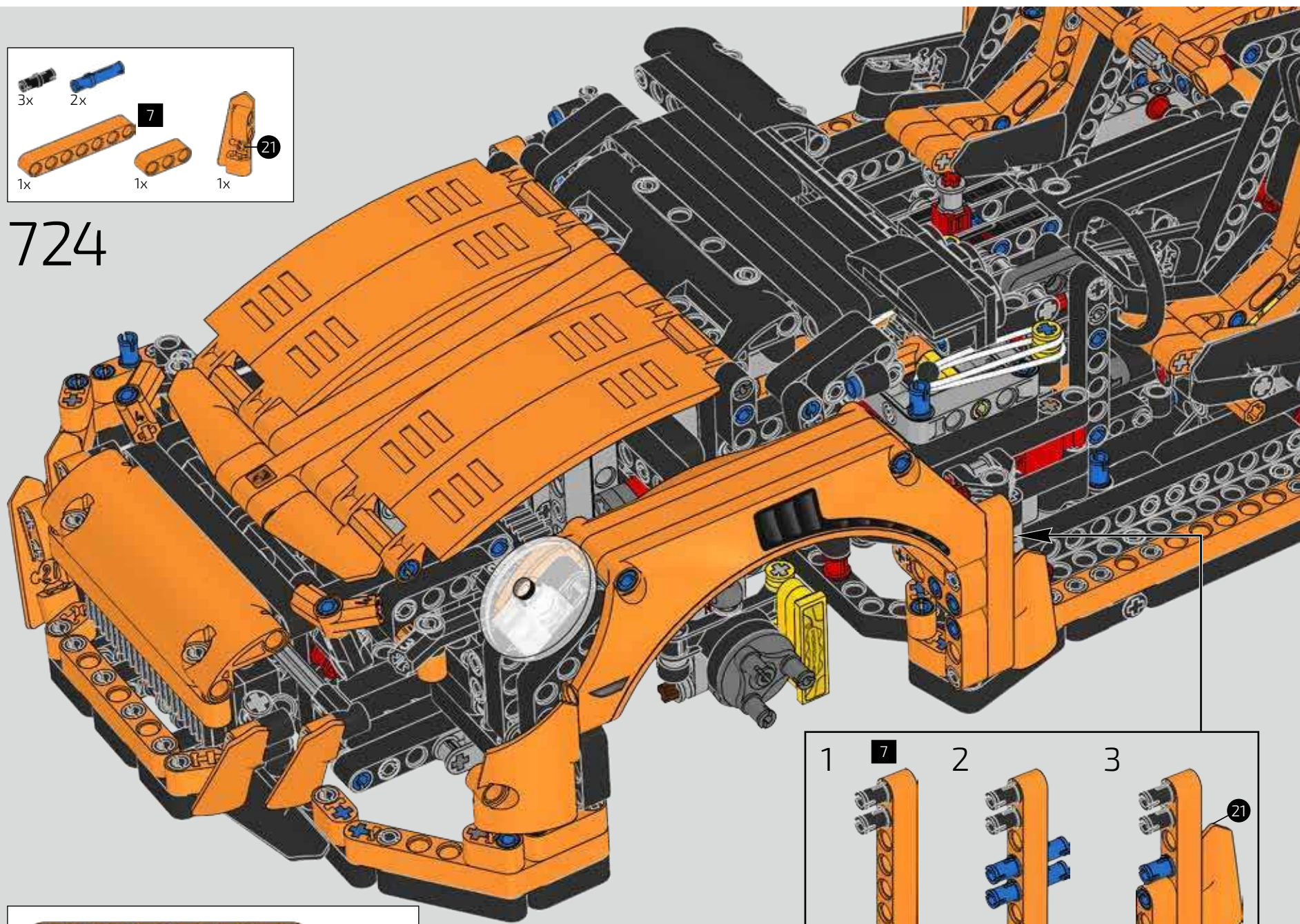

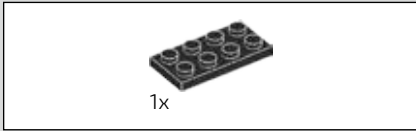
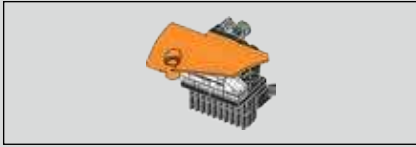

725

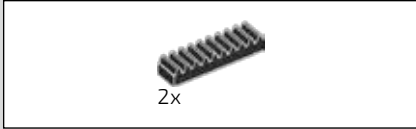
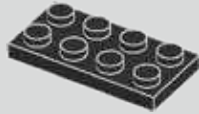

726

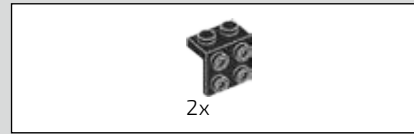
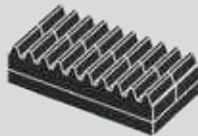

727

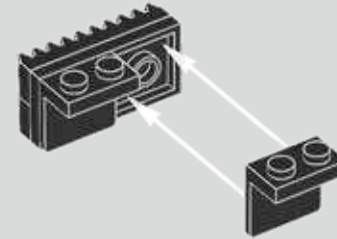
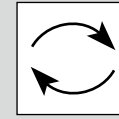

728

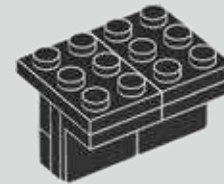

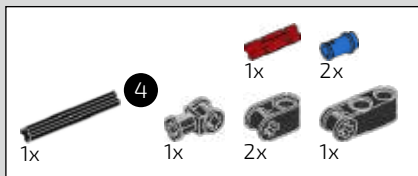

729

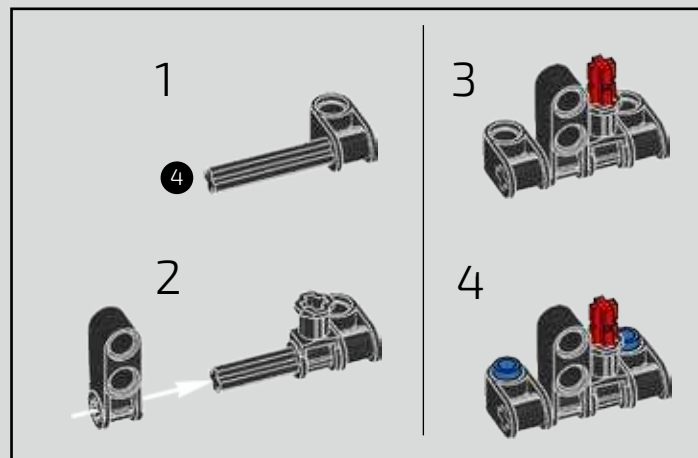

730

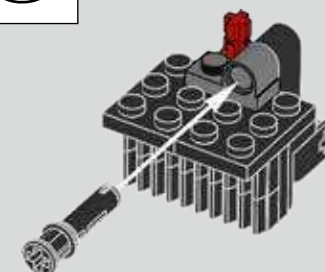
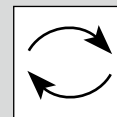

731

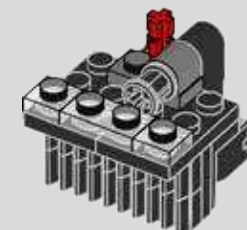

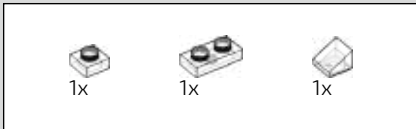

732

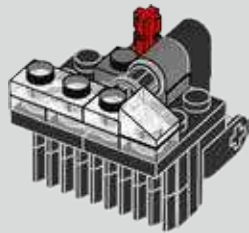

733

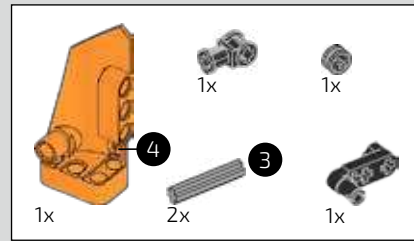
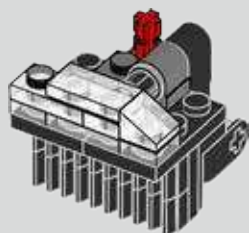

734

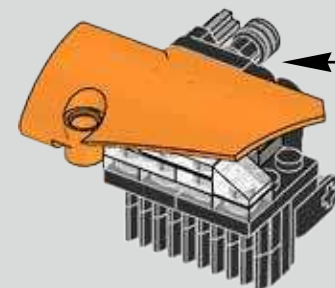
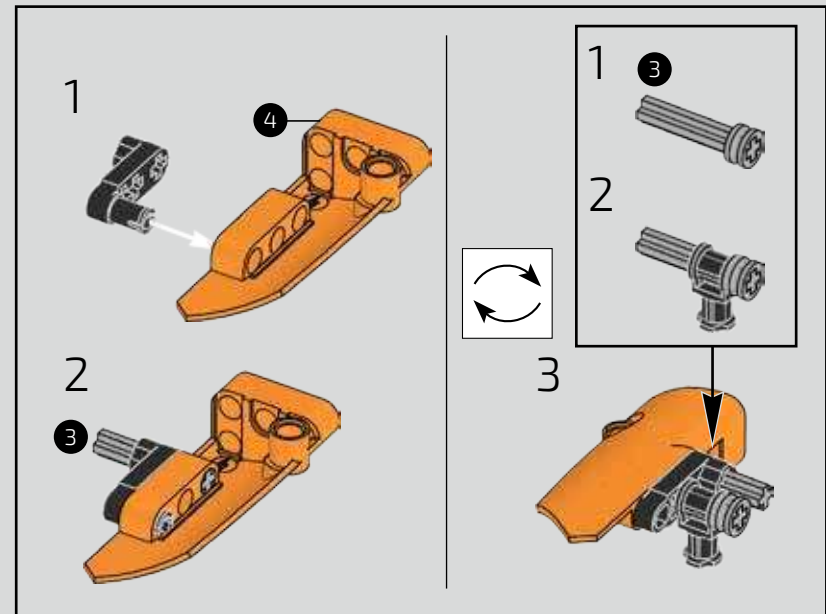
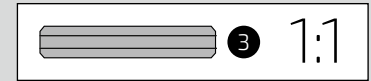

735

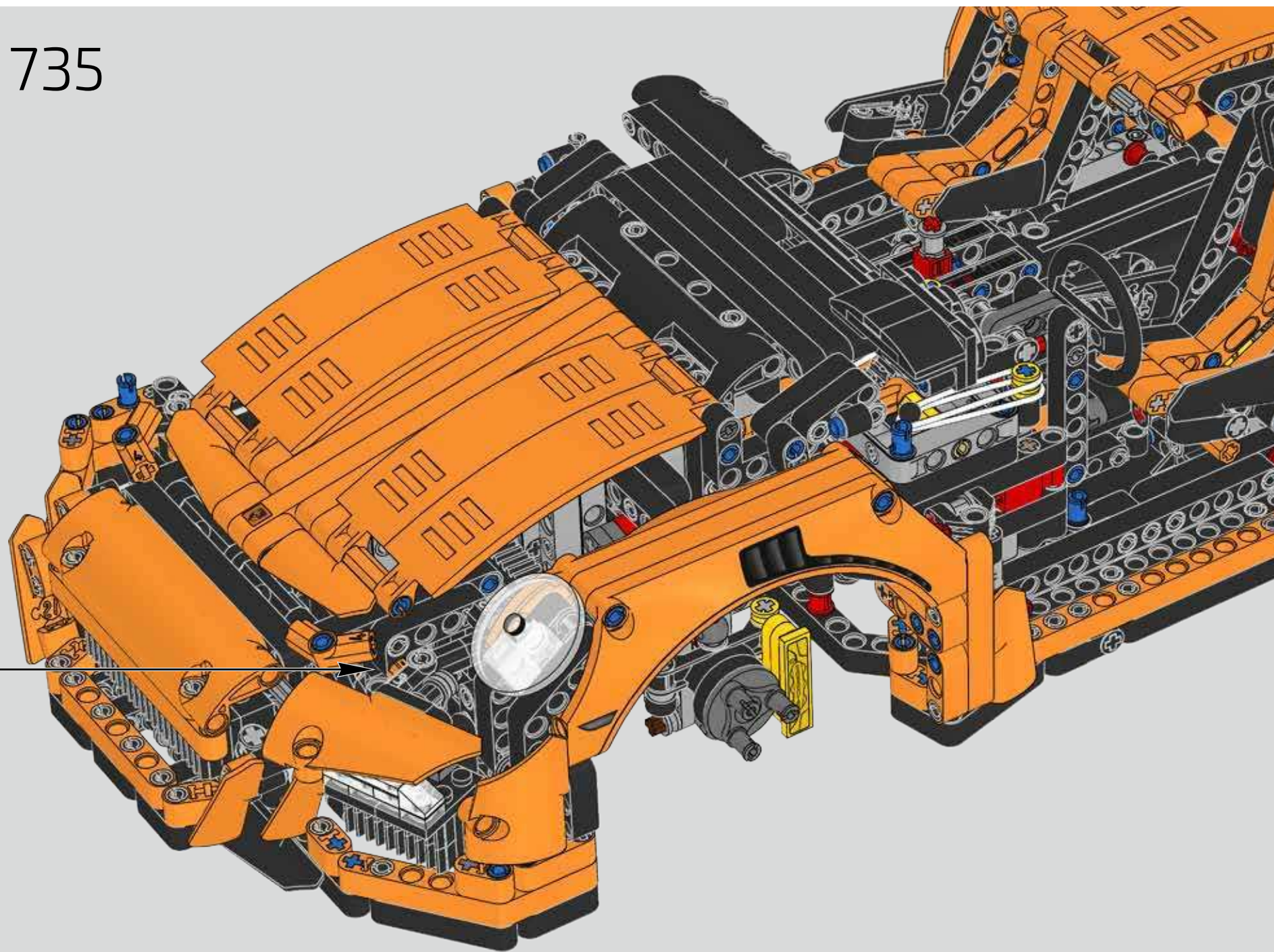

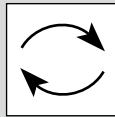
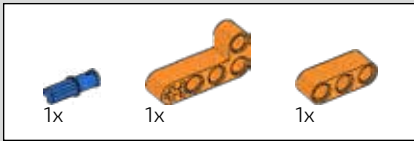

736

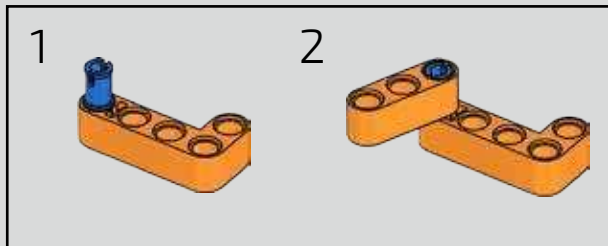
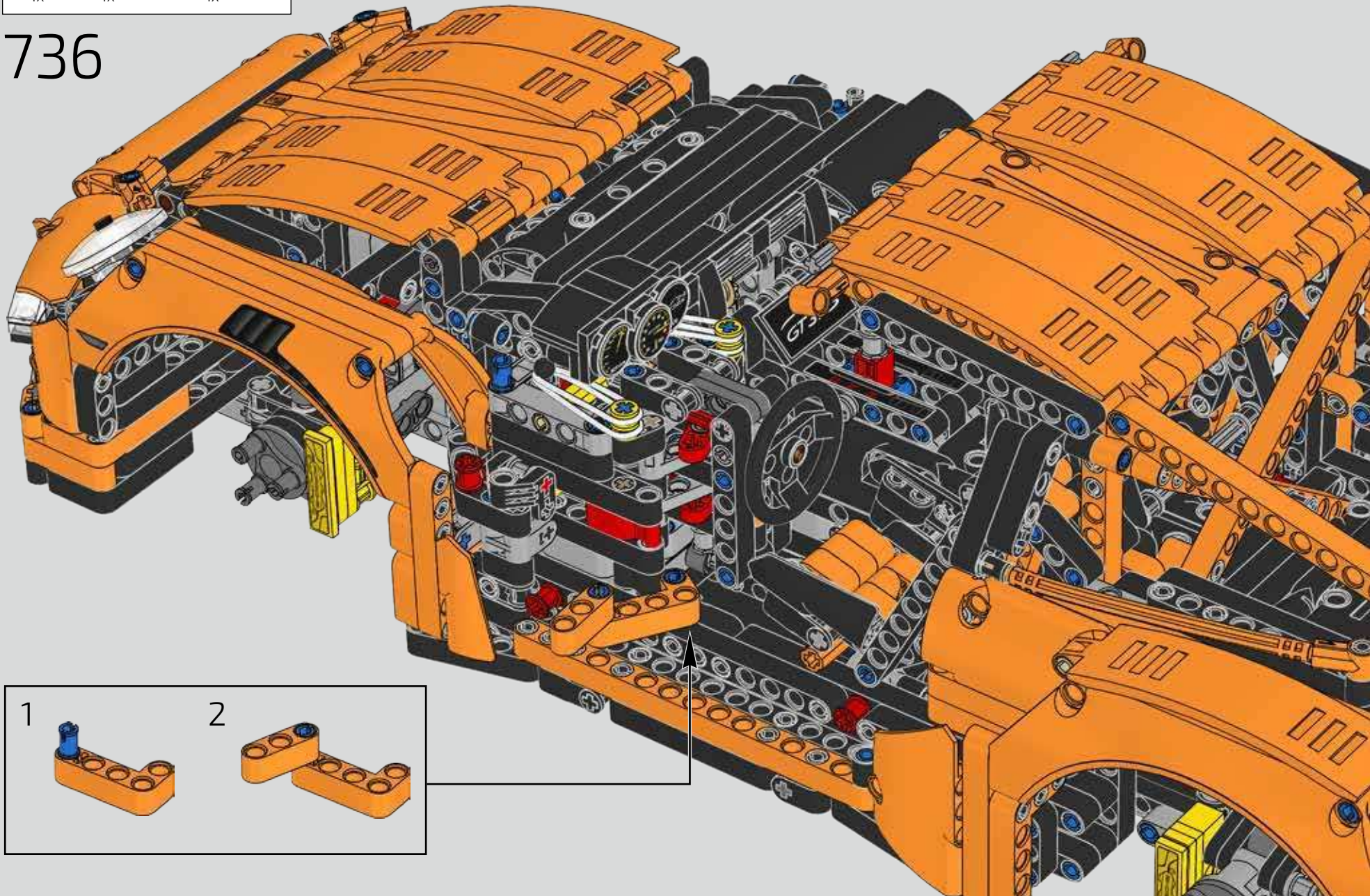

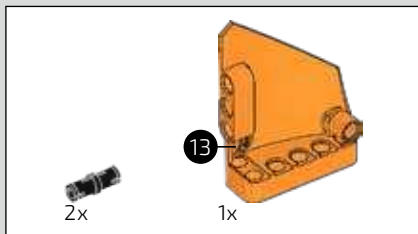
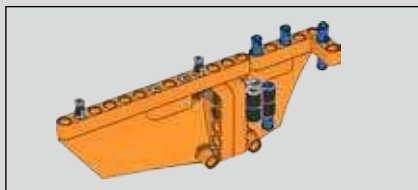

737

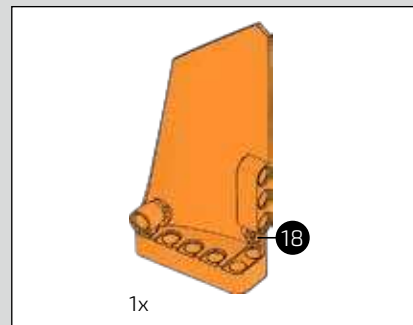
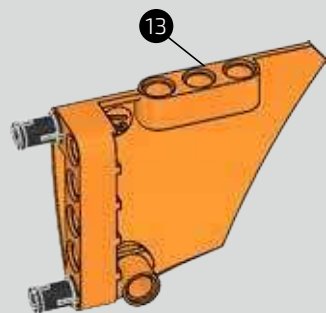

738

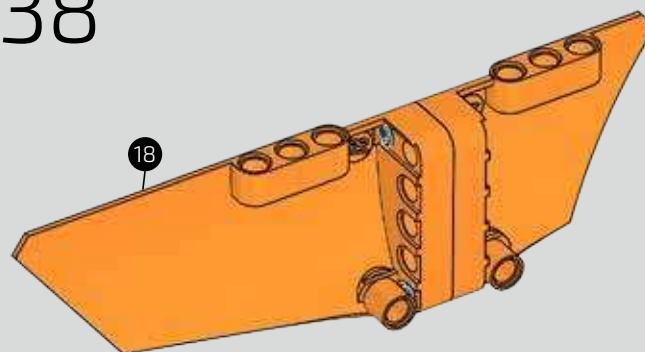

739

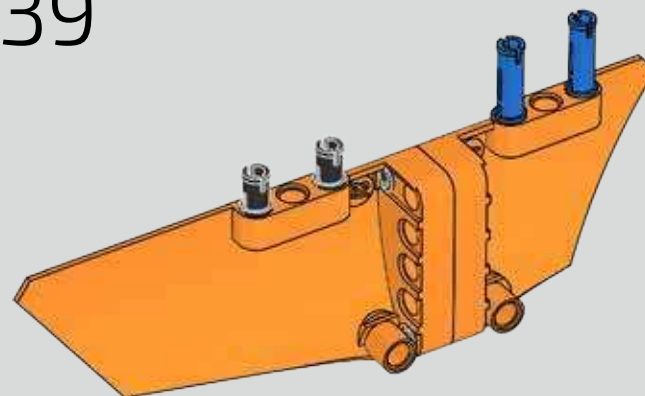

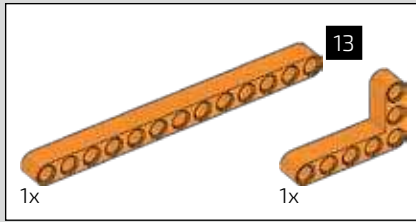

740

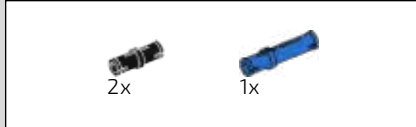
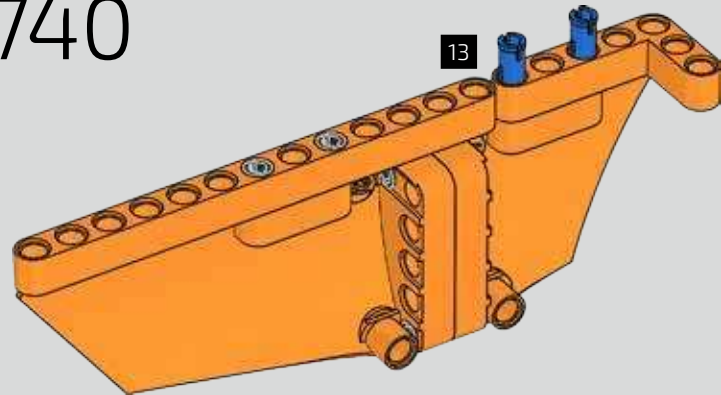

741

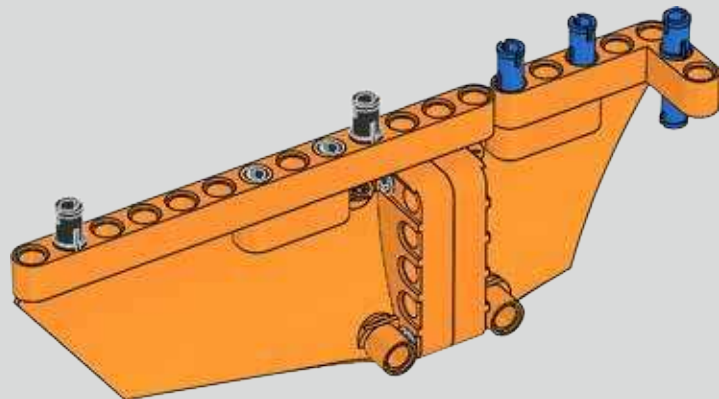

742

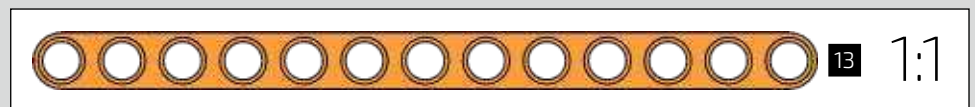
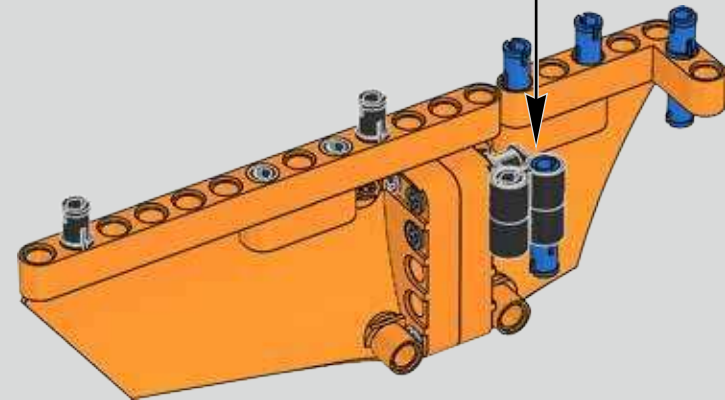
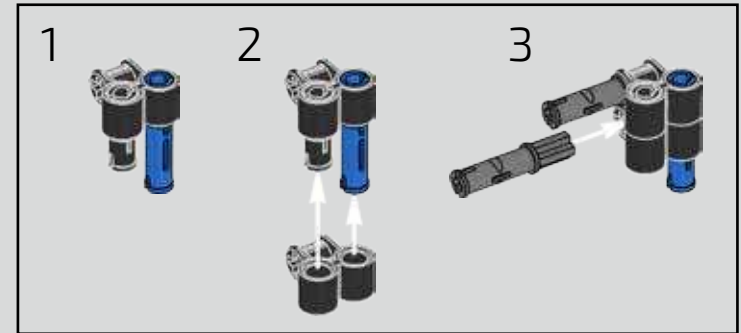

743

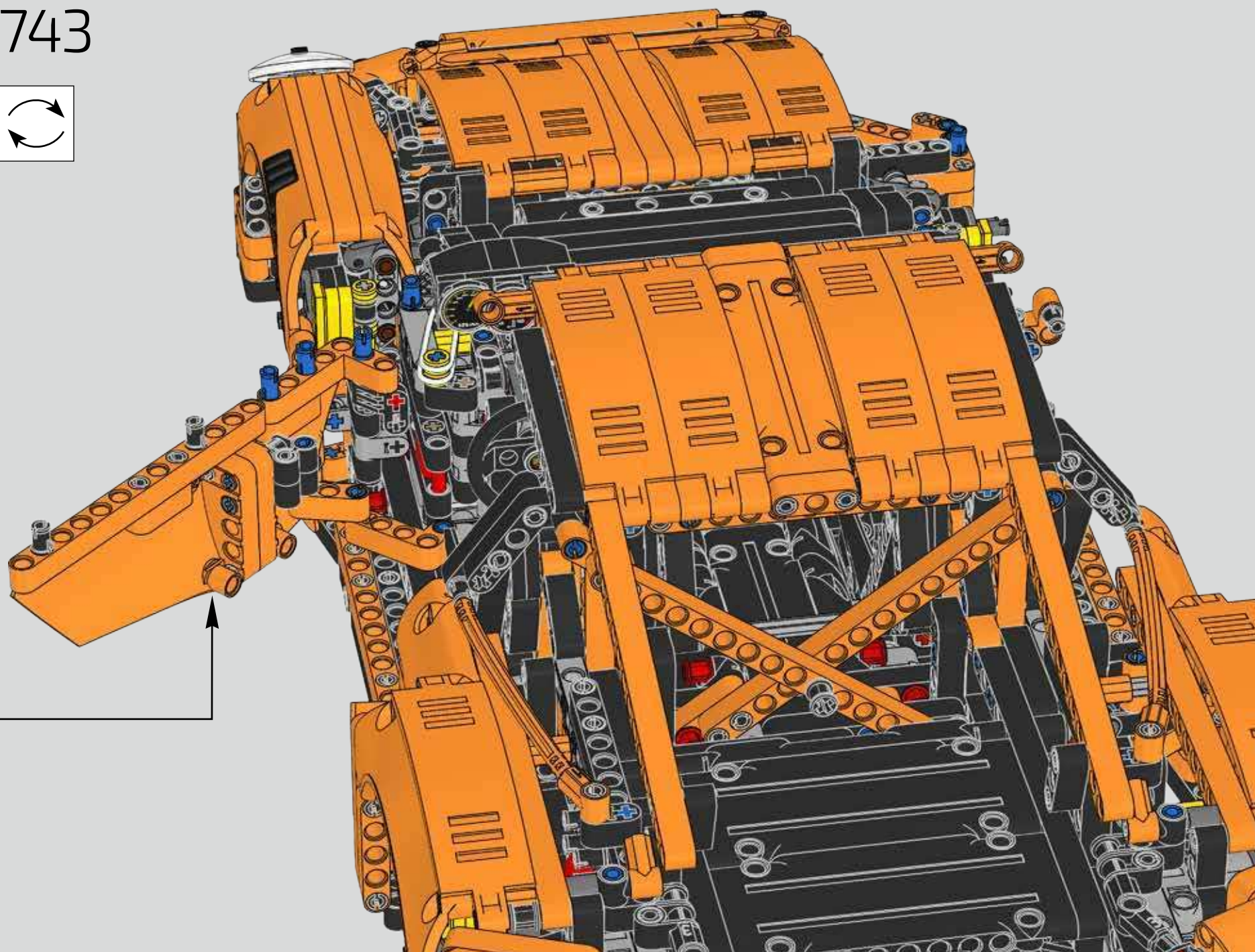
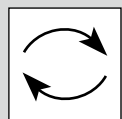

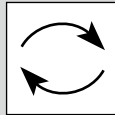
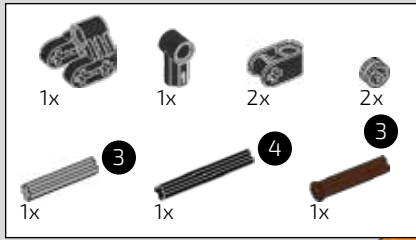

744

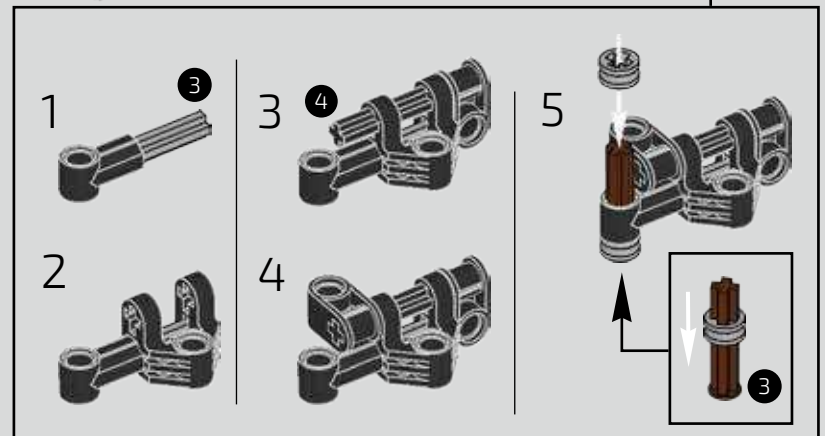
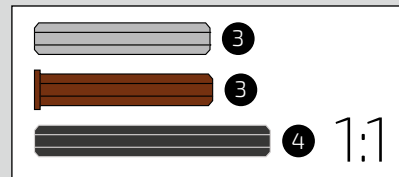
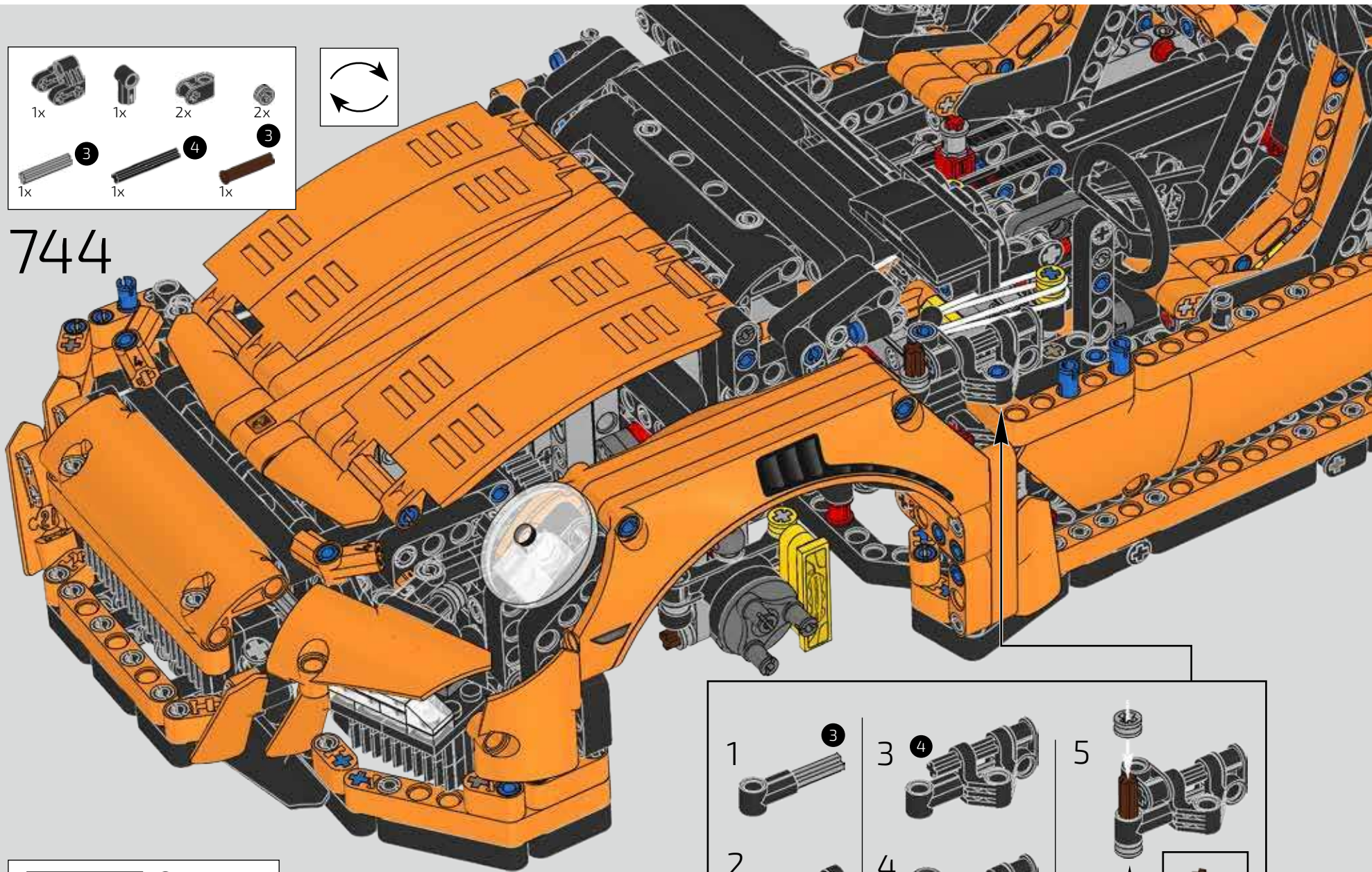



745

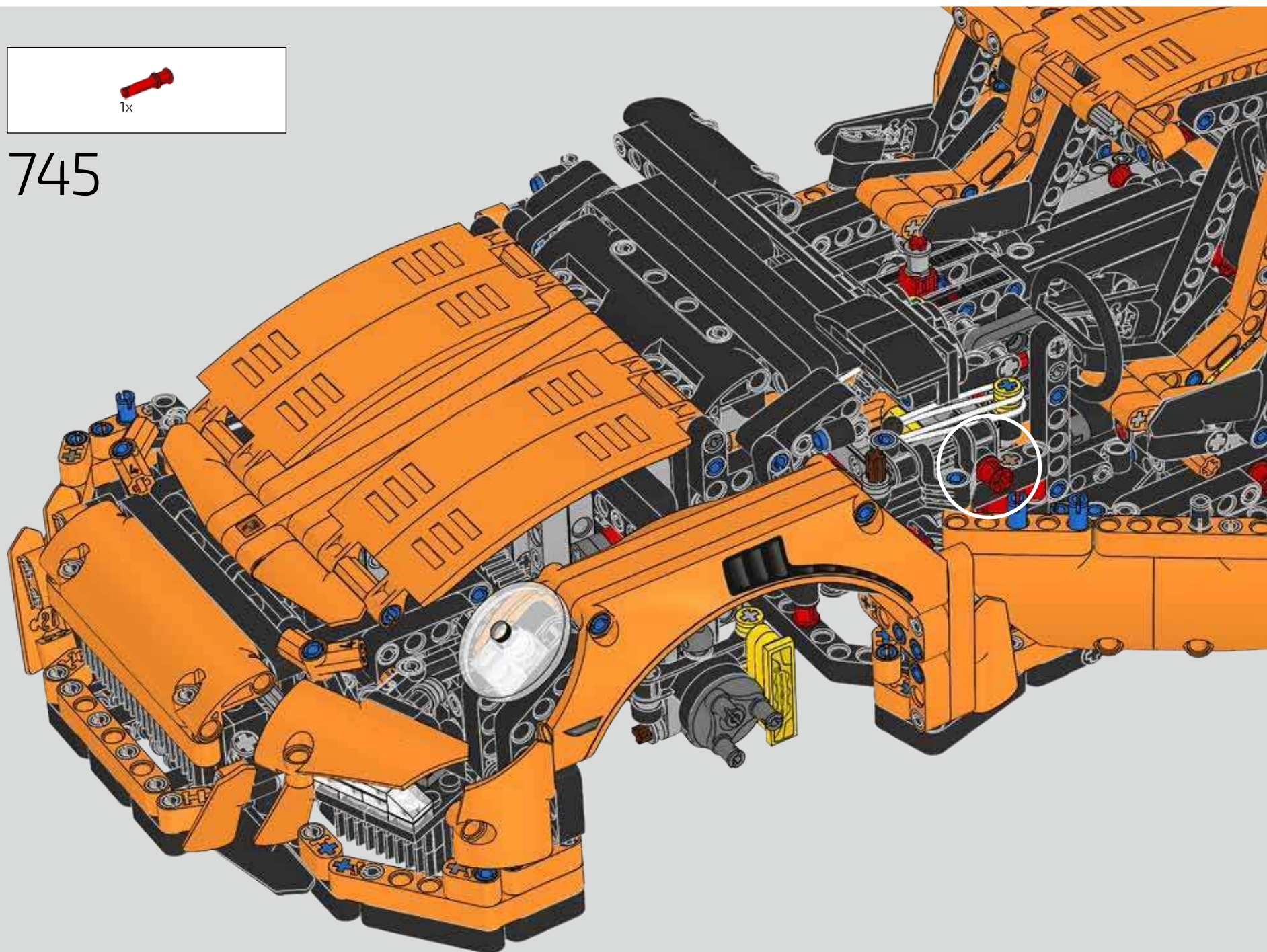



746

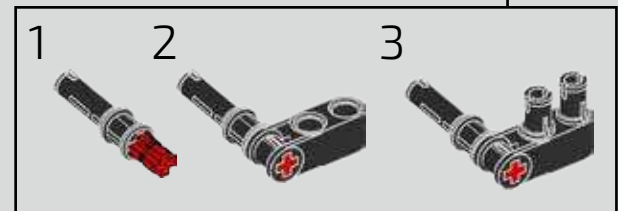
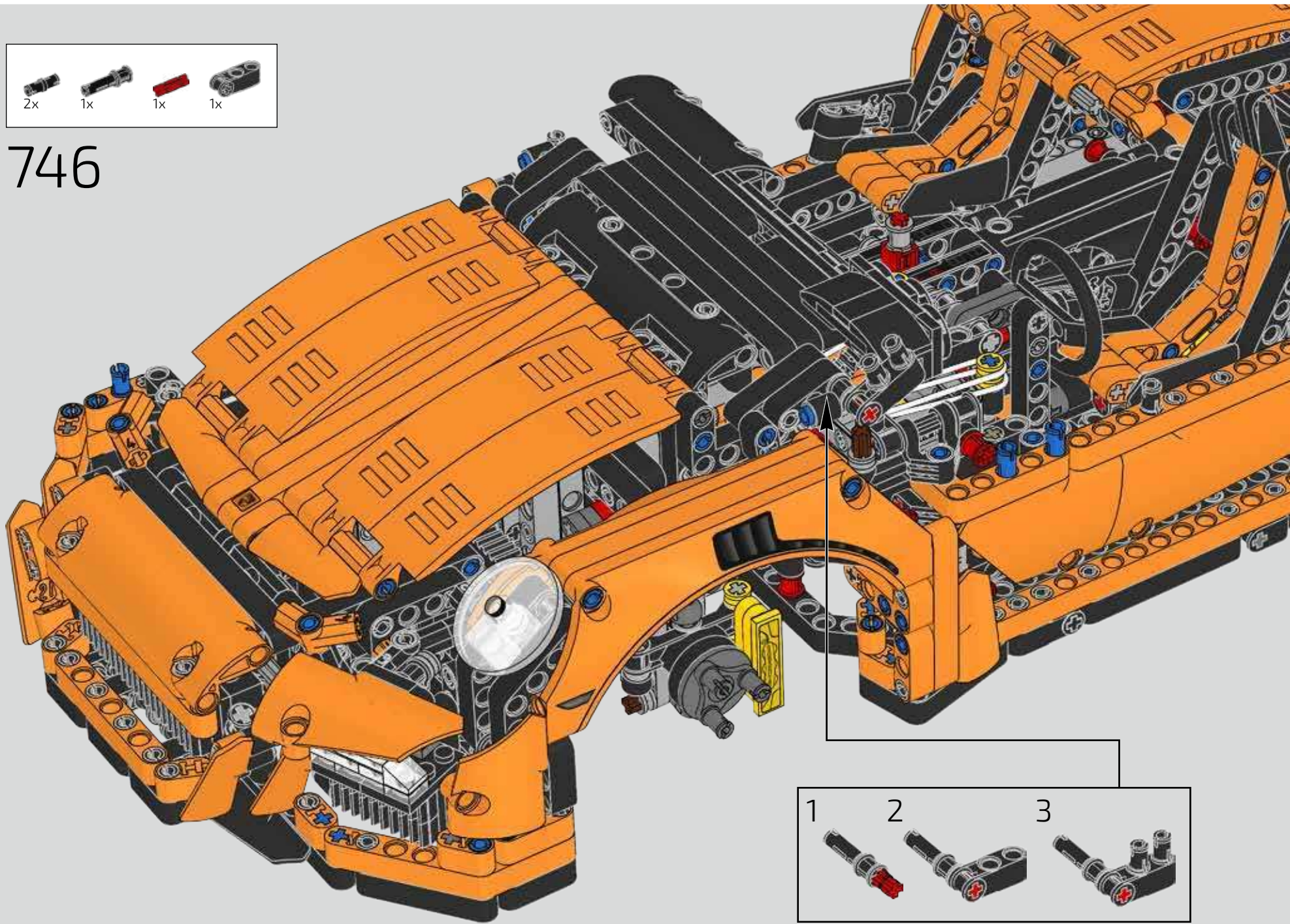



747

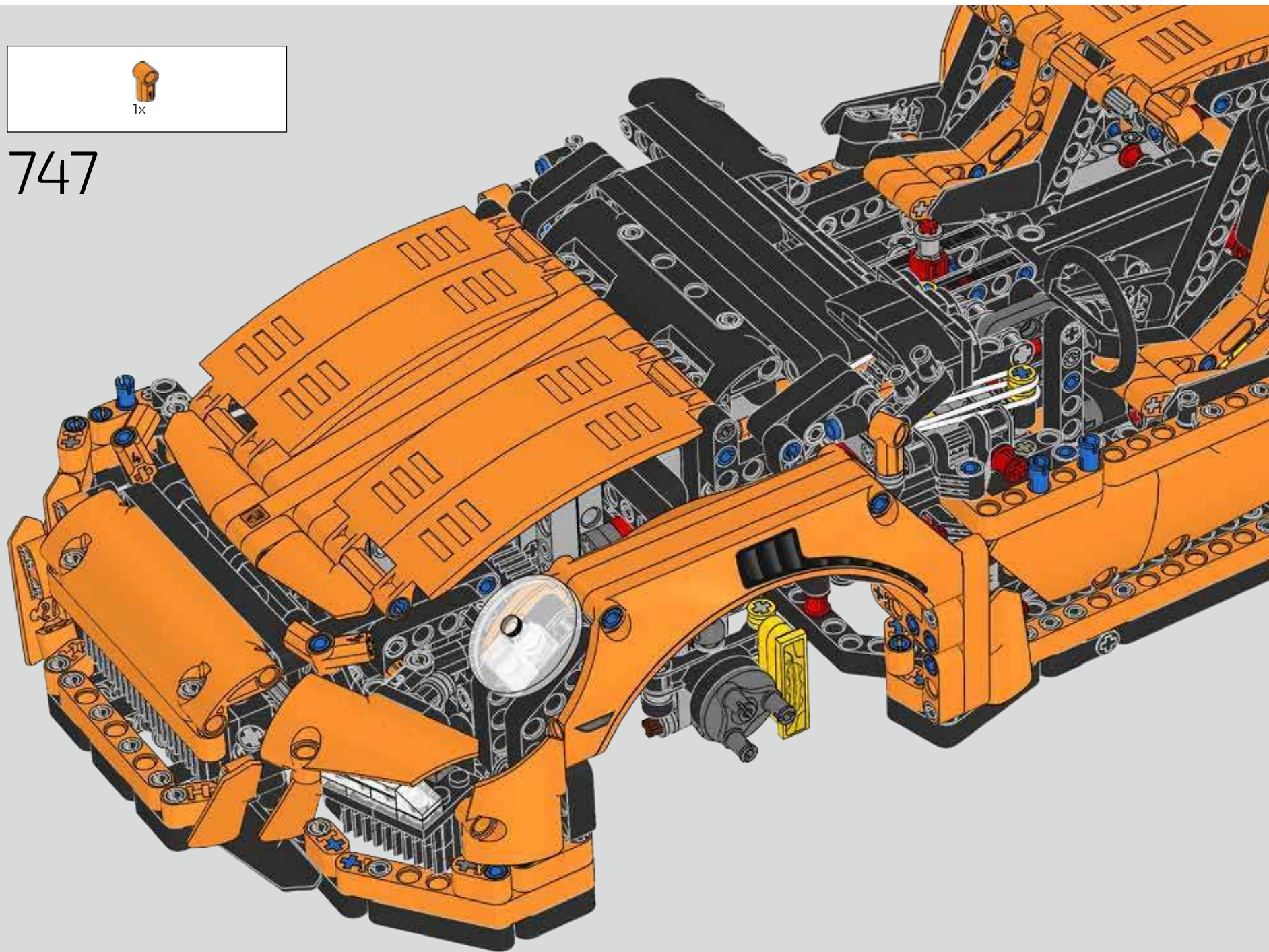

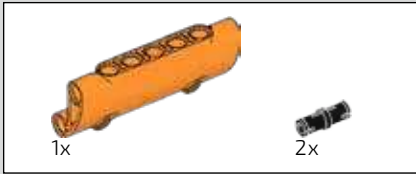
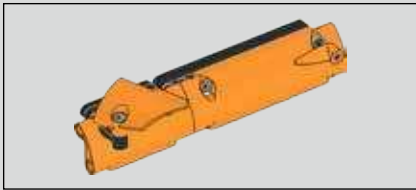

748

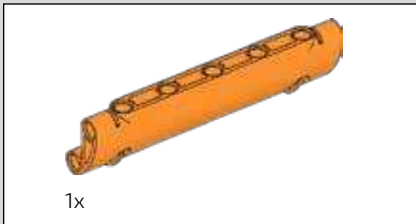
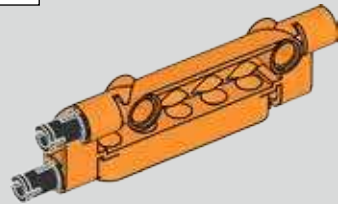

749

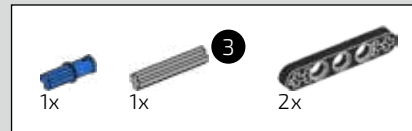
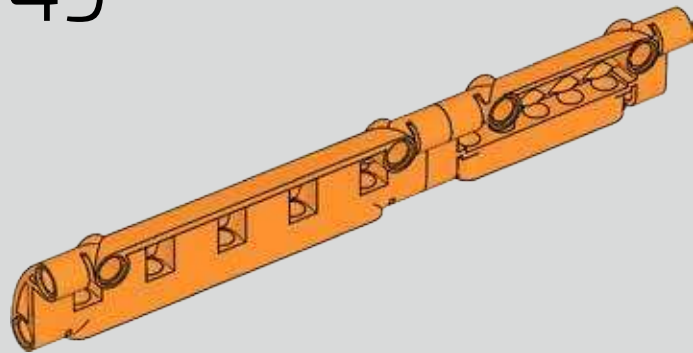

750

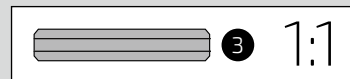
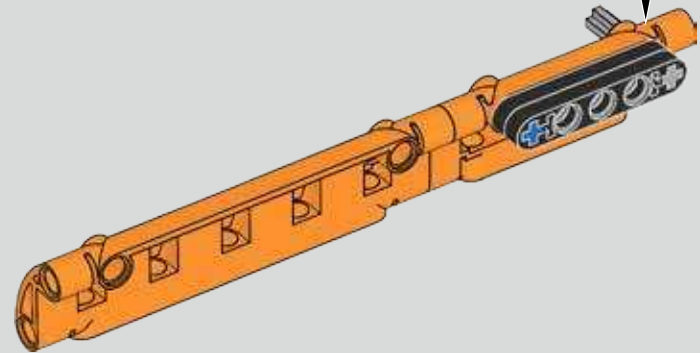
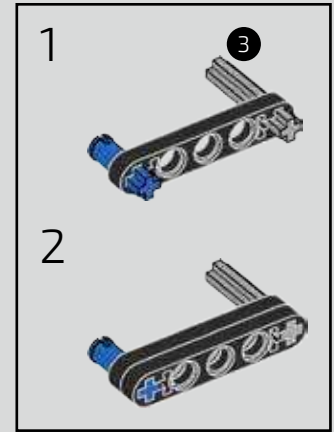

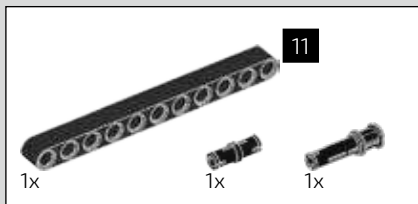

751

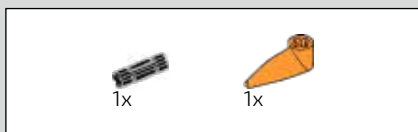
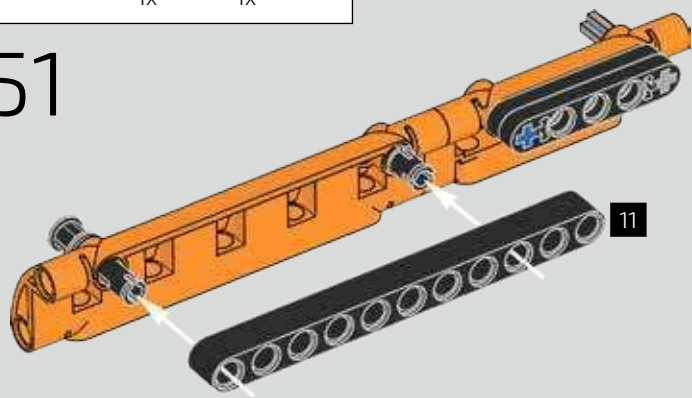

752

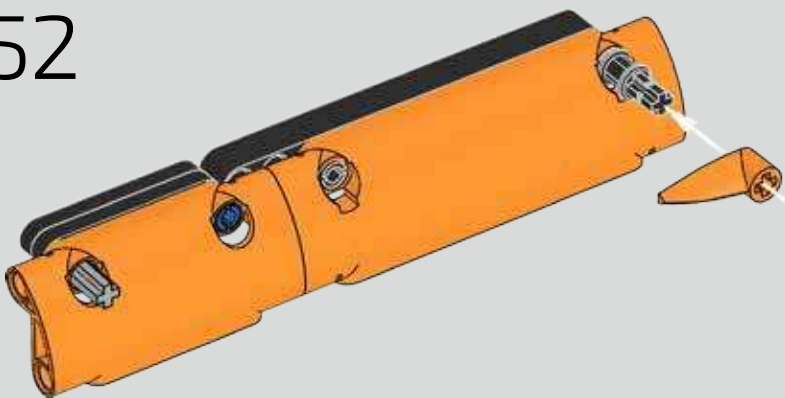
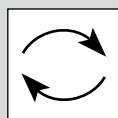

753

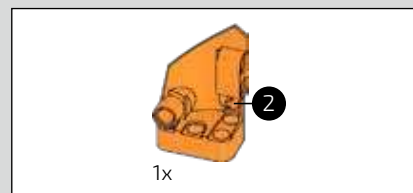
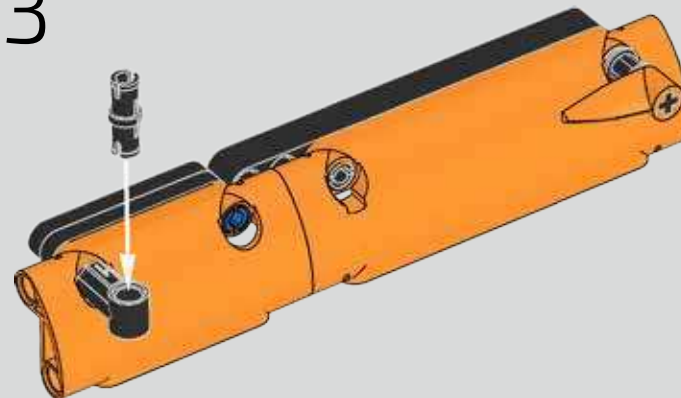

754

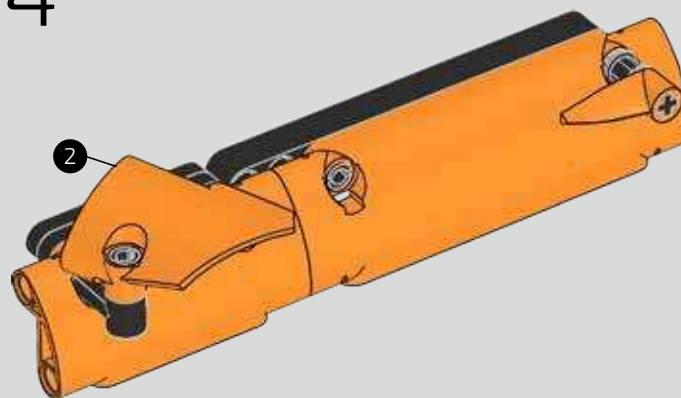

755

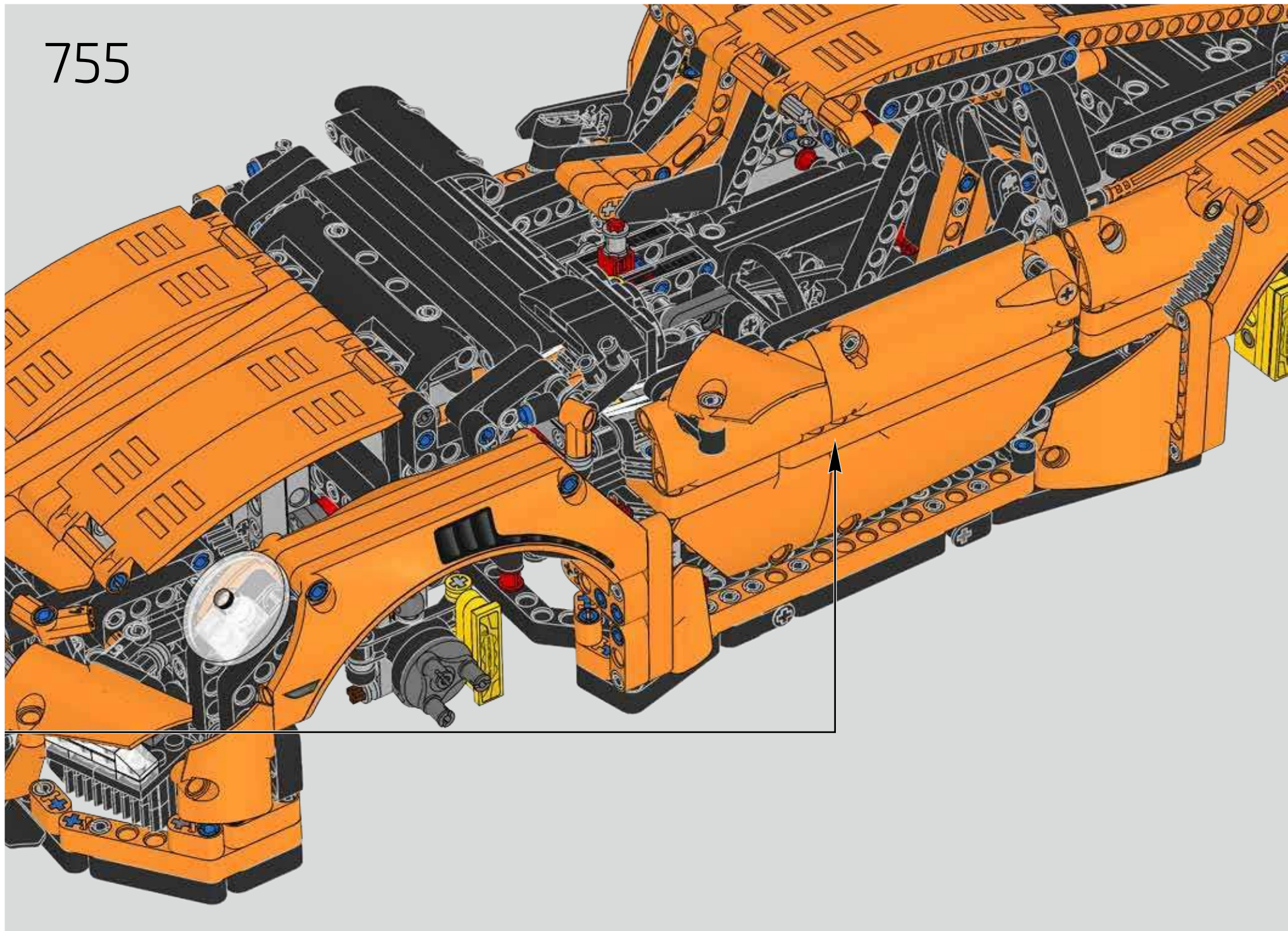

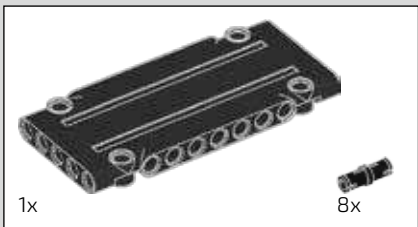
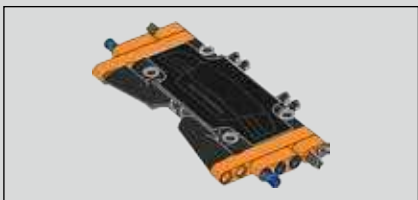

756

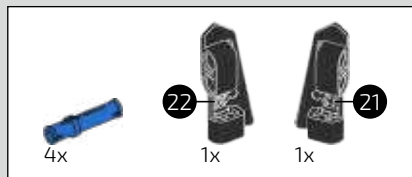
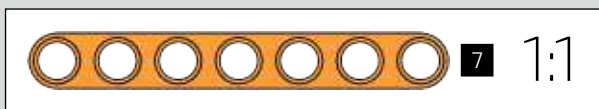
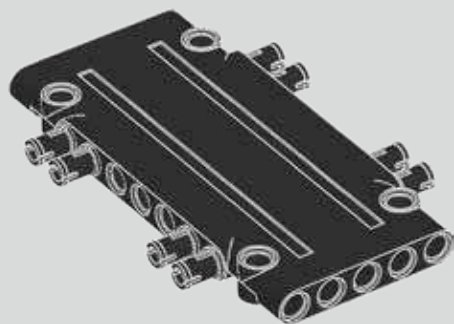

757

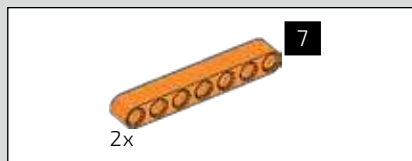
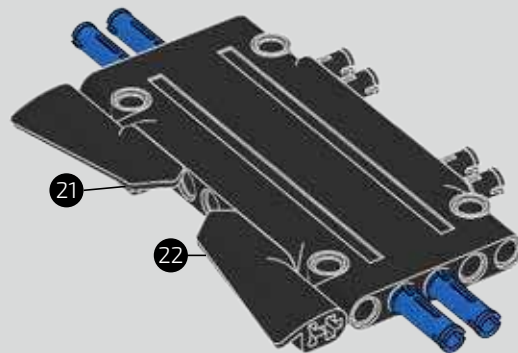

758

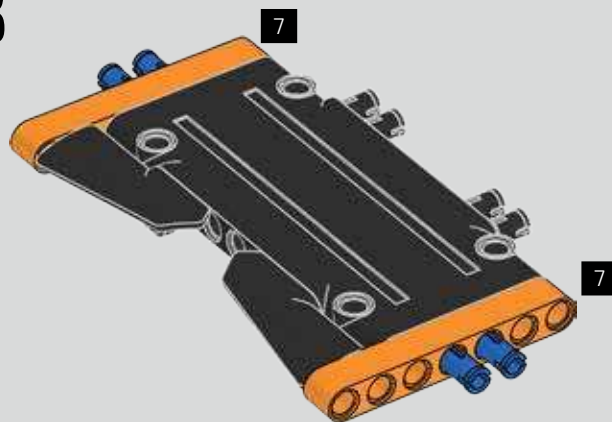



759

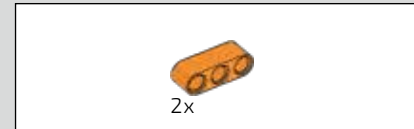
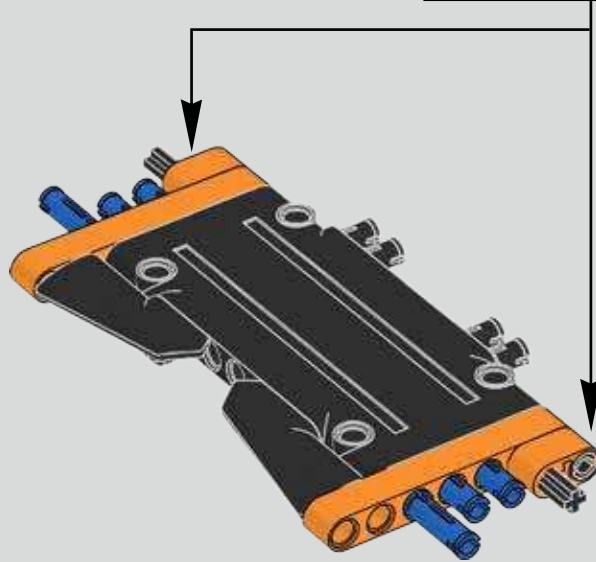
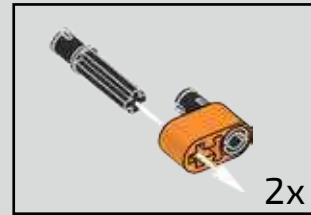

760

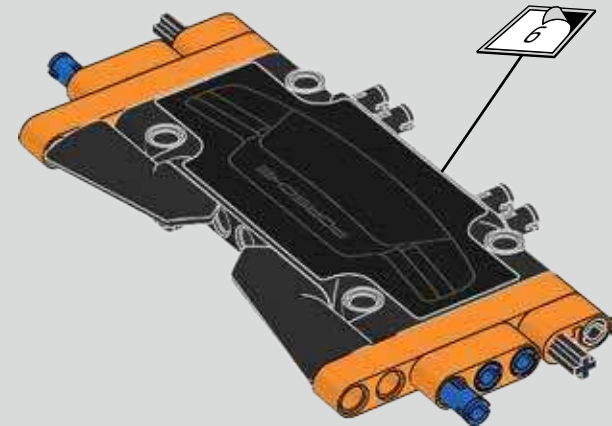

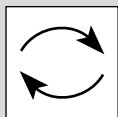

761

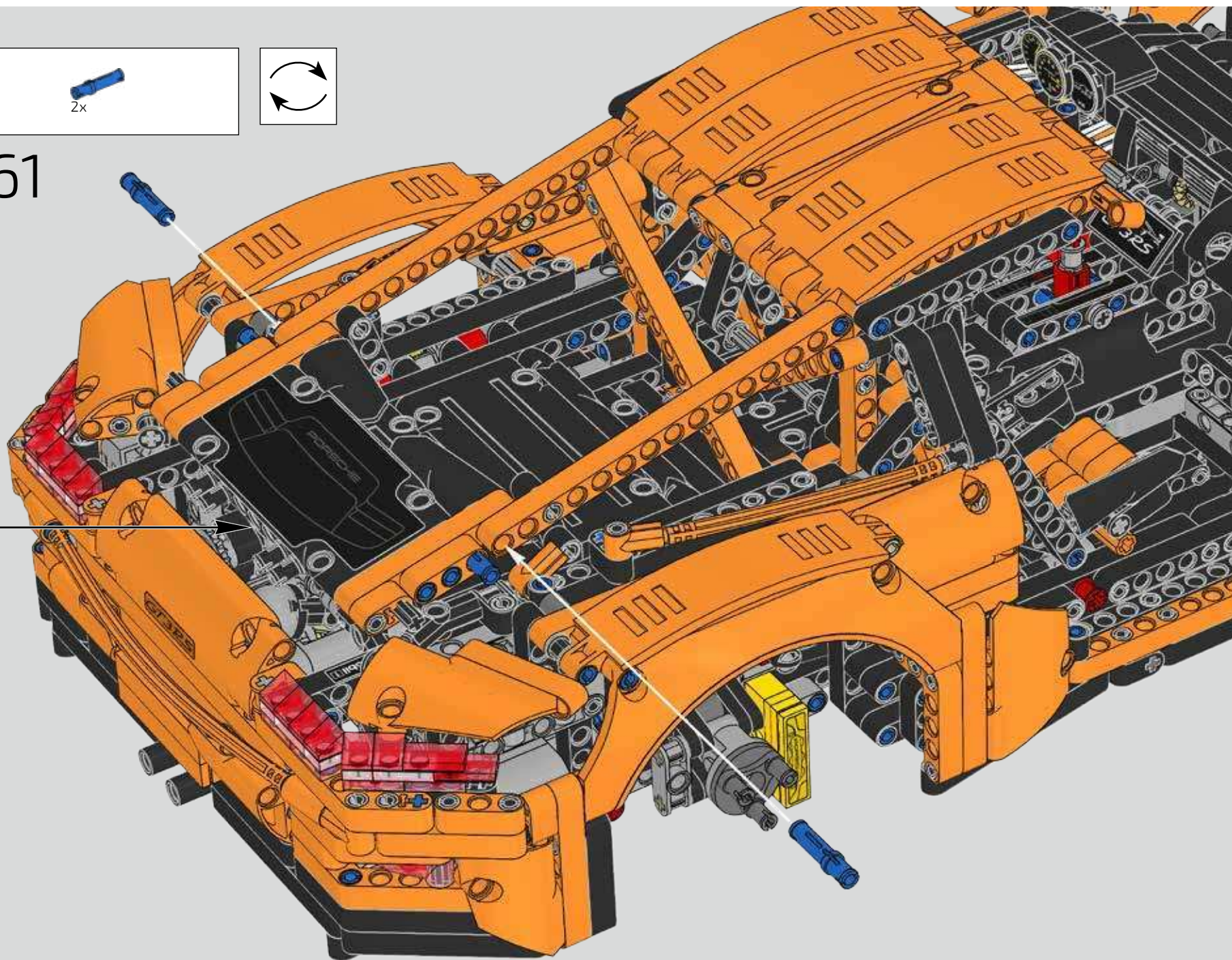

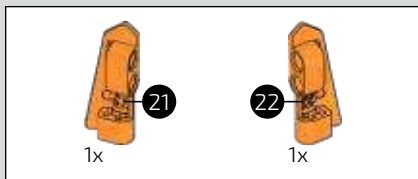

762

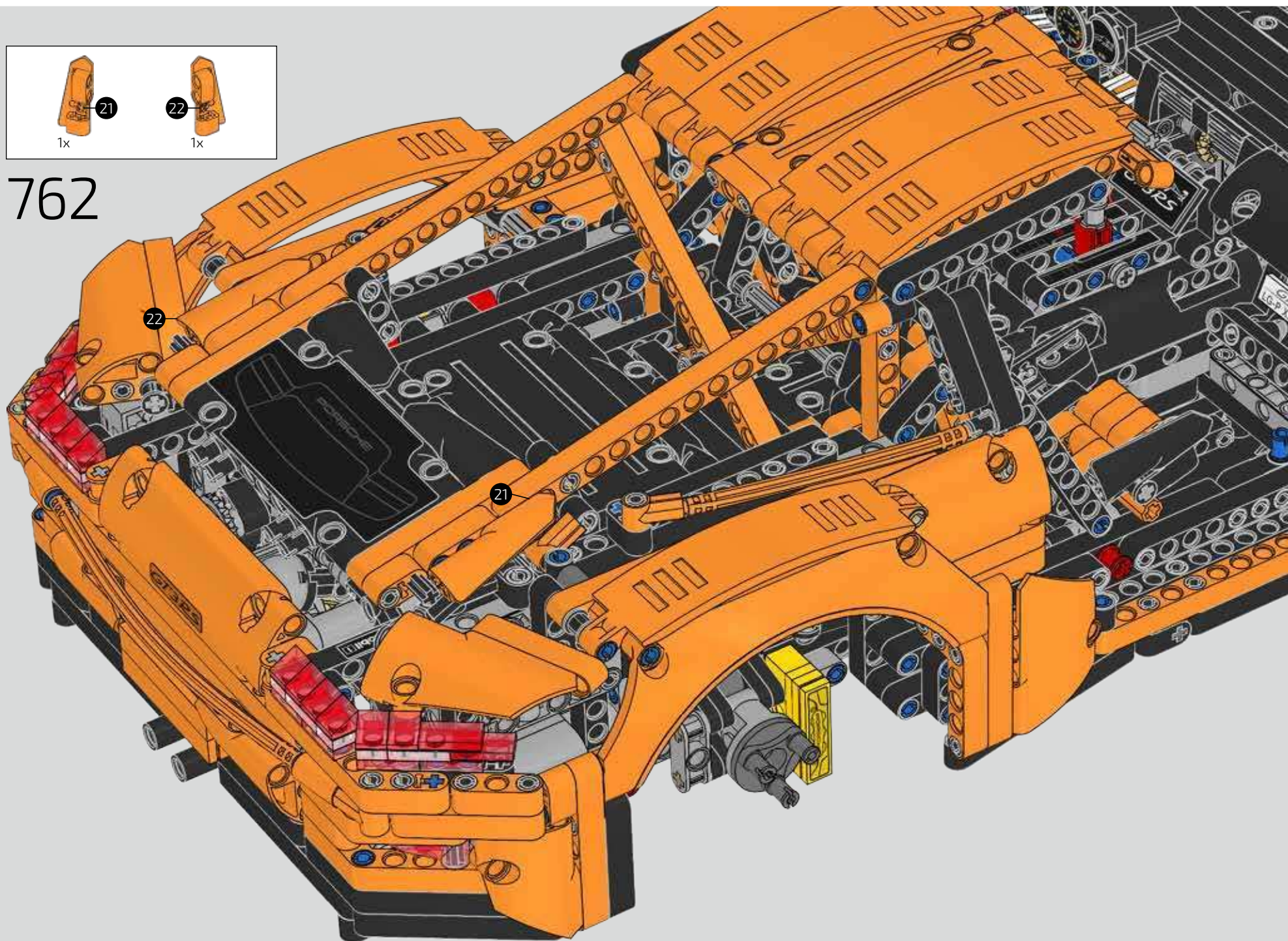

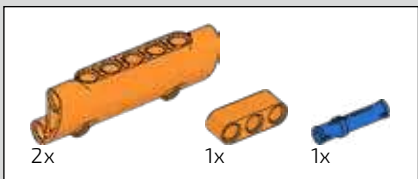

763

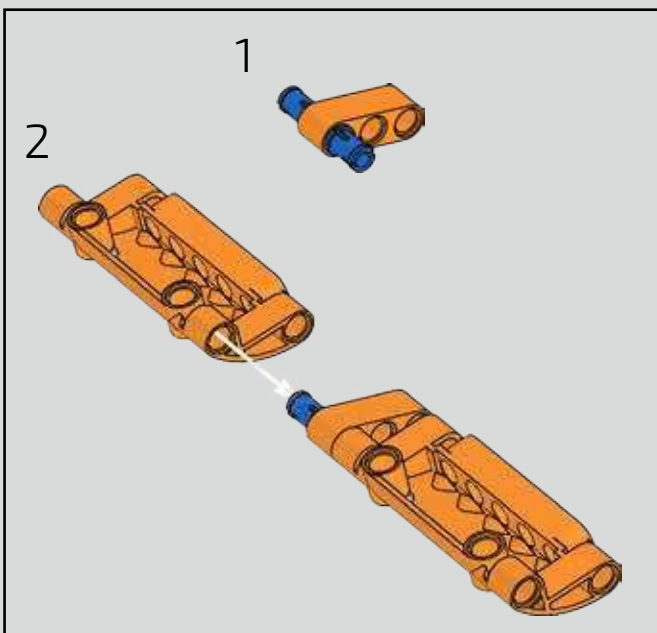
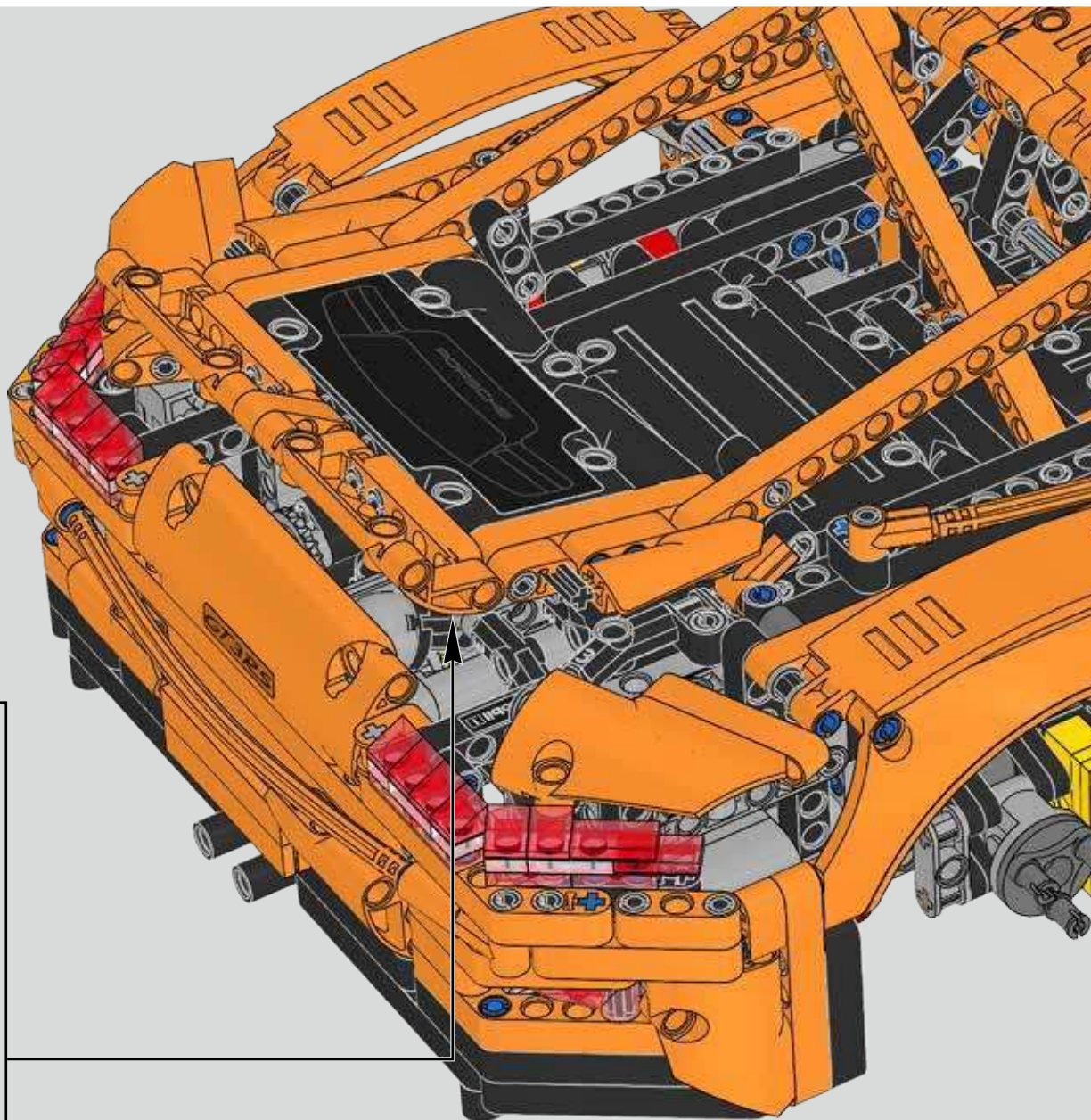

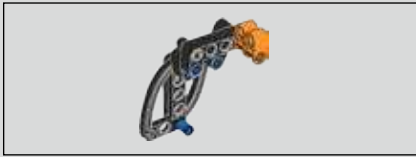

764

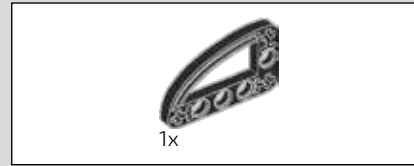
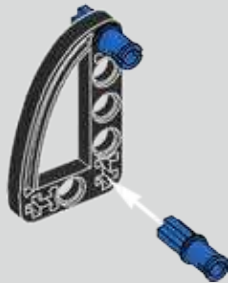

765



766

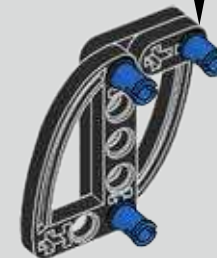



767

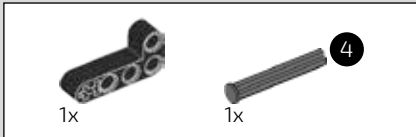
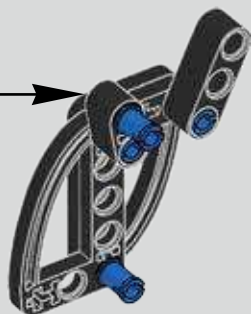
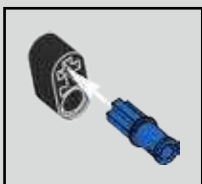

768

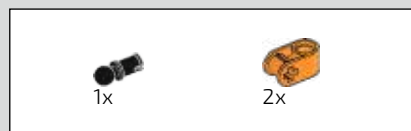
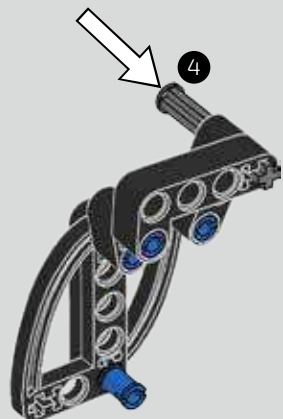

769

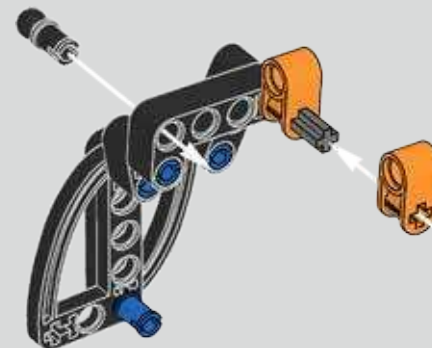

770

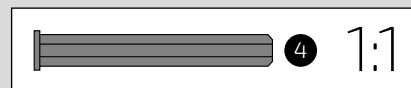
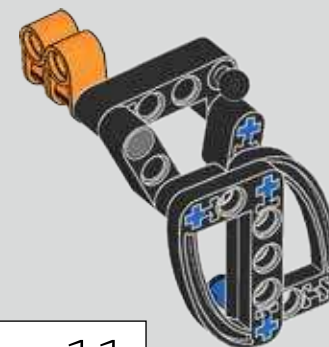
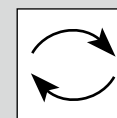

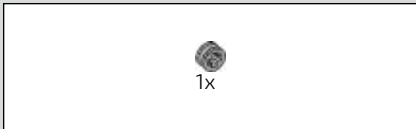

771

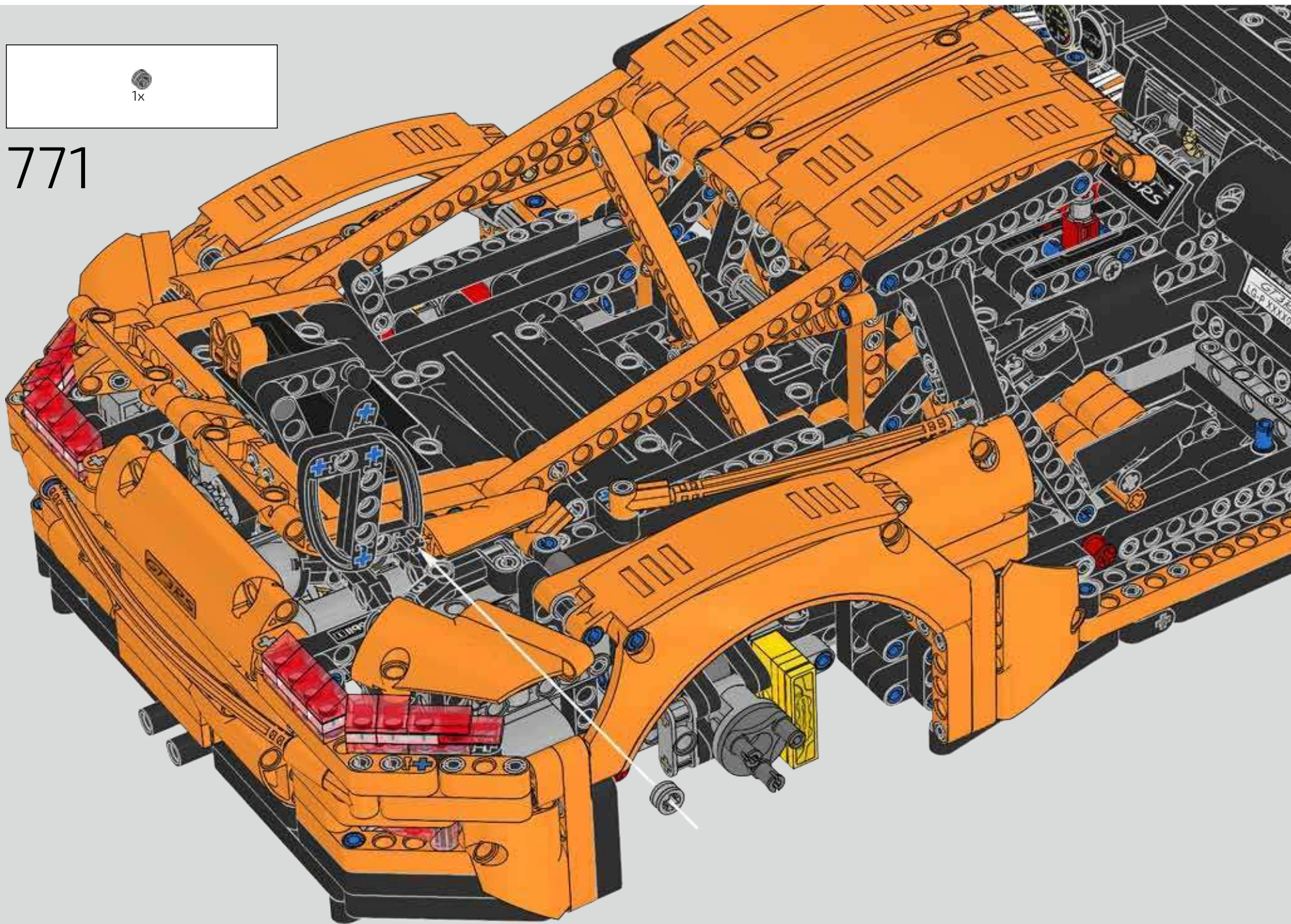

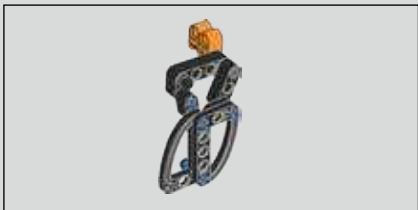

772

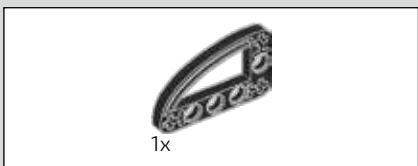
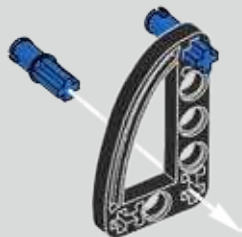

773

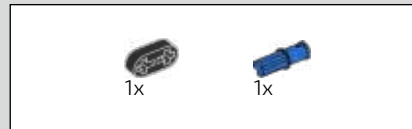

774



775



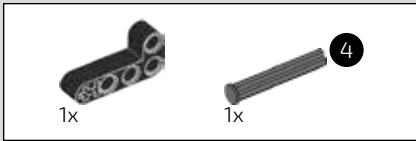

776

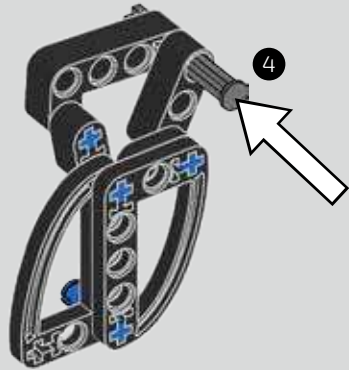

777



778



779

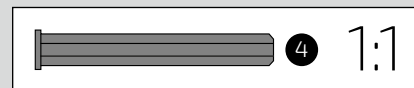
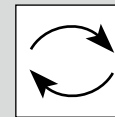

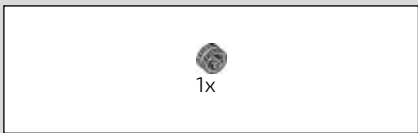

780

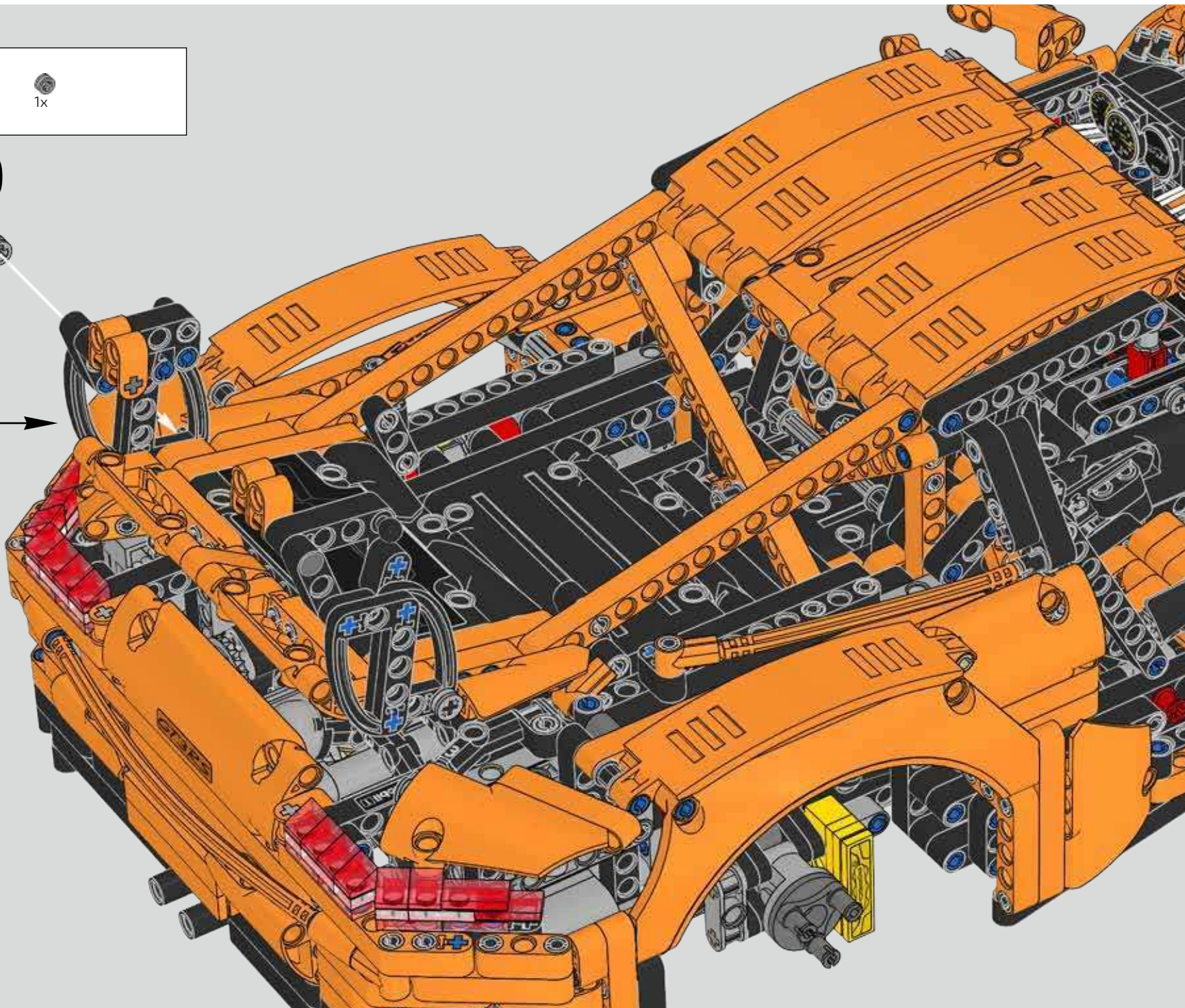

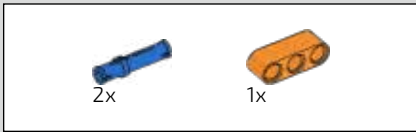
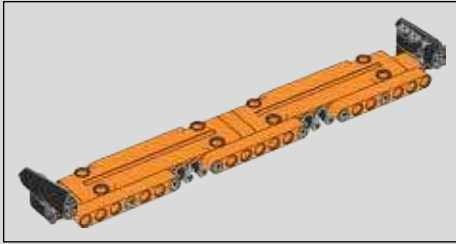

781

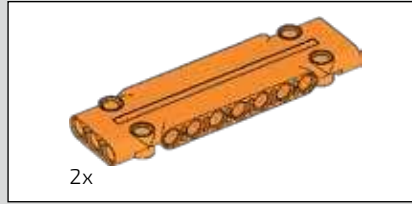
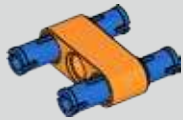

2x

782

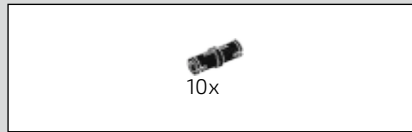
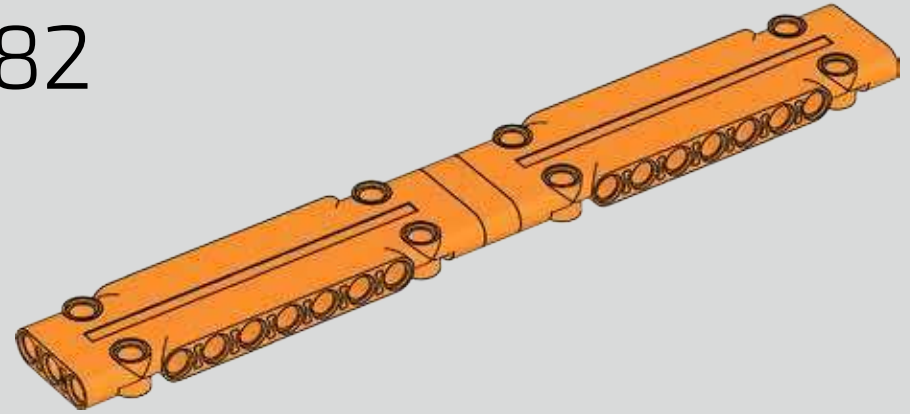

10x

783

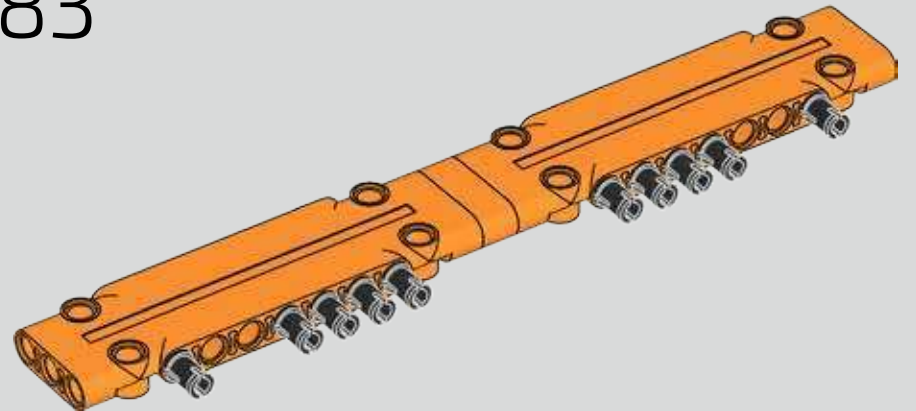

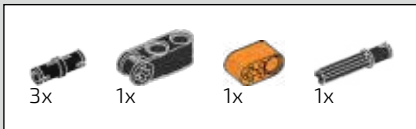

784

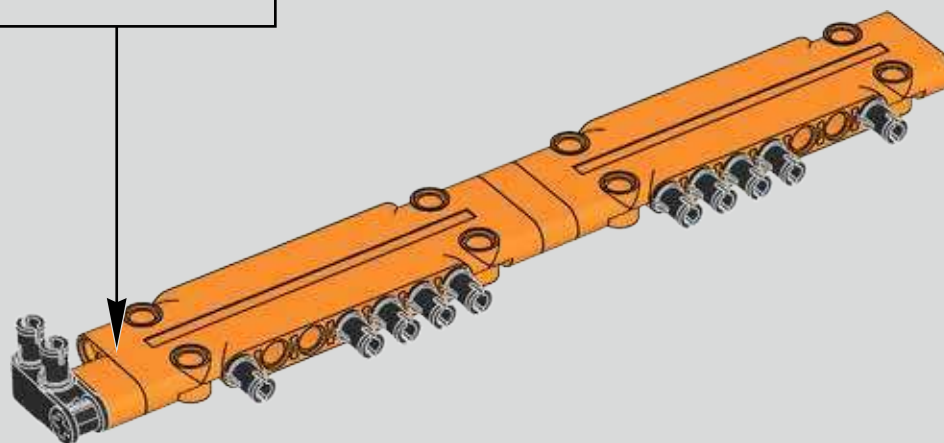
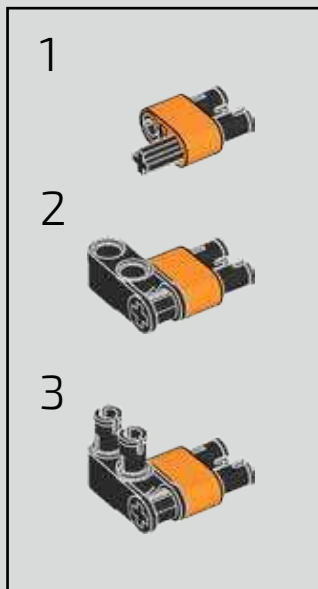

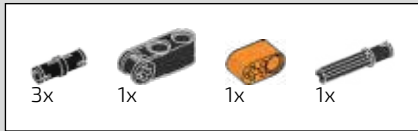

785

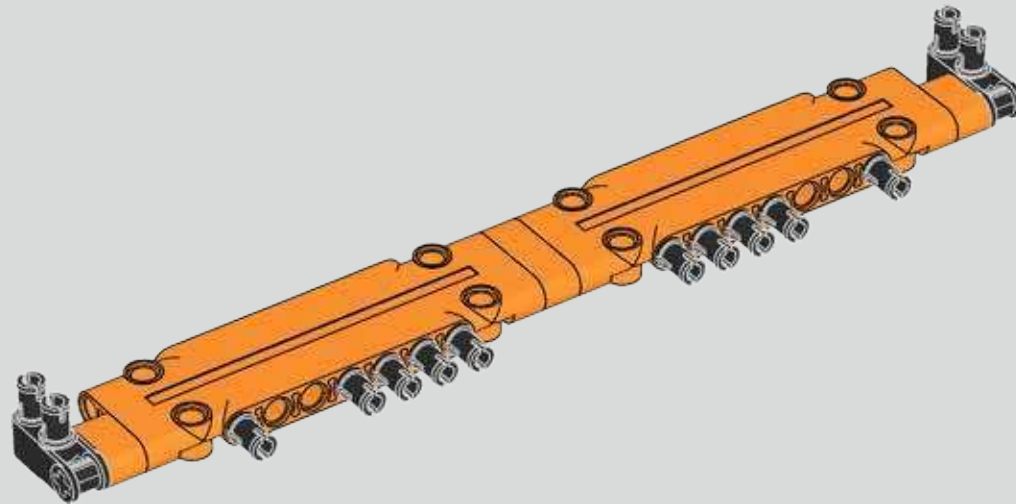
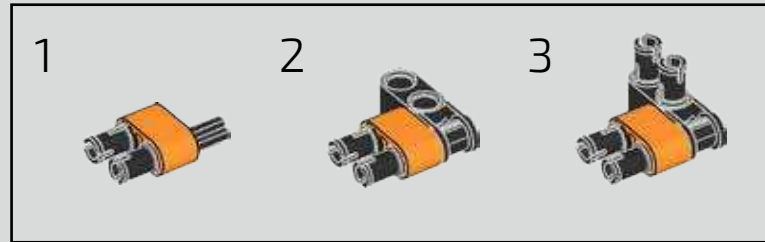

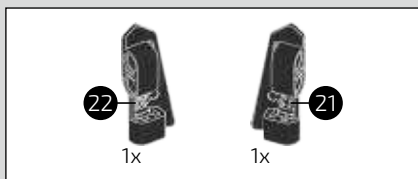

786

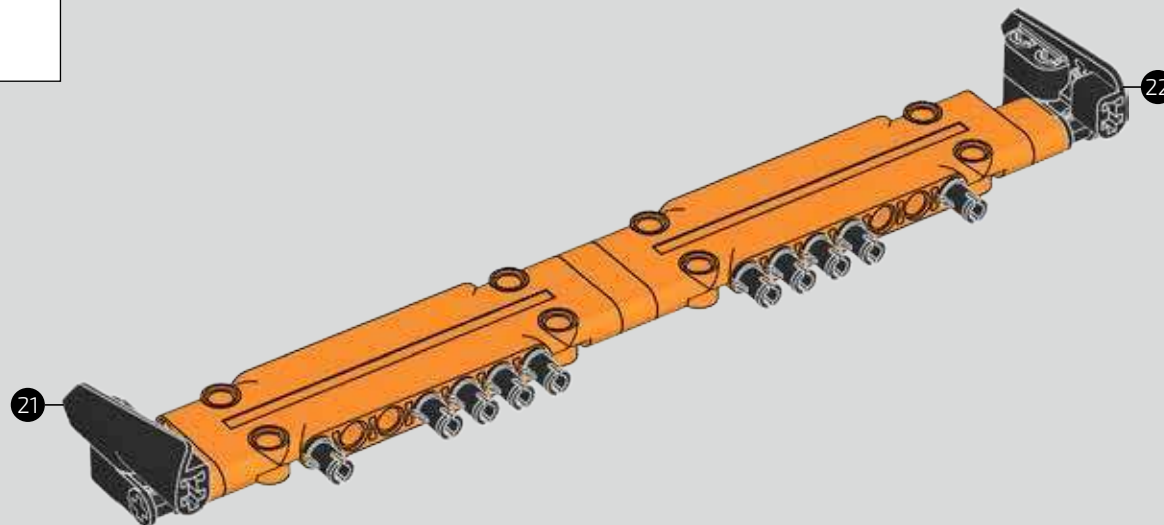

787

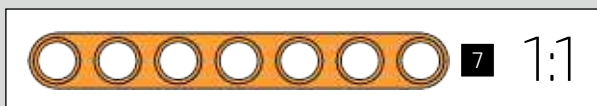
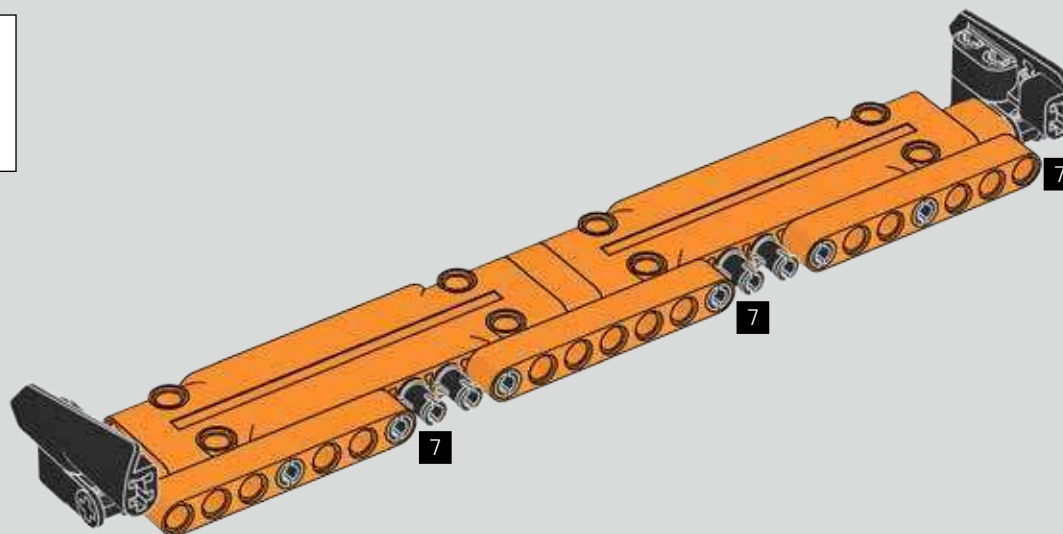

788

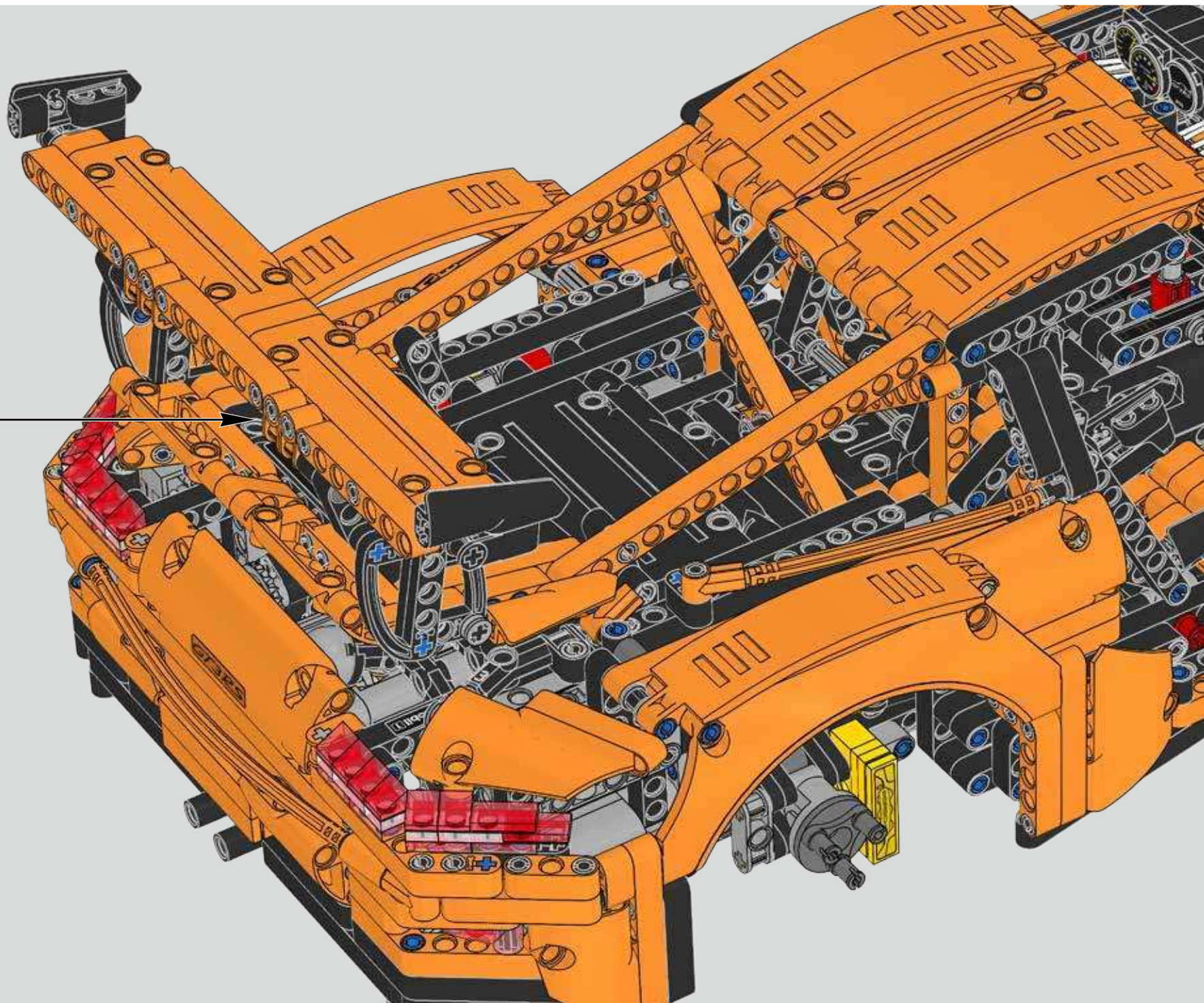

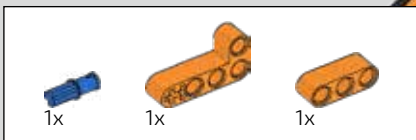

789

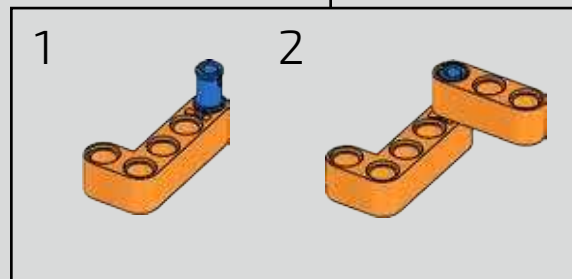
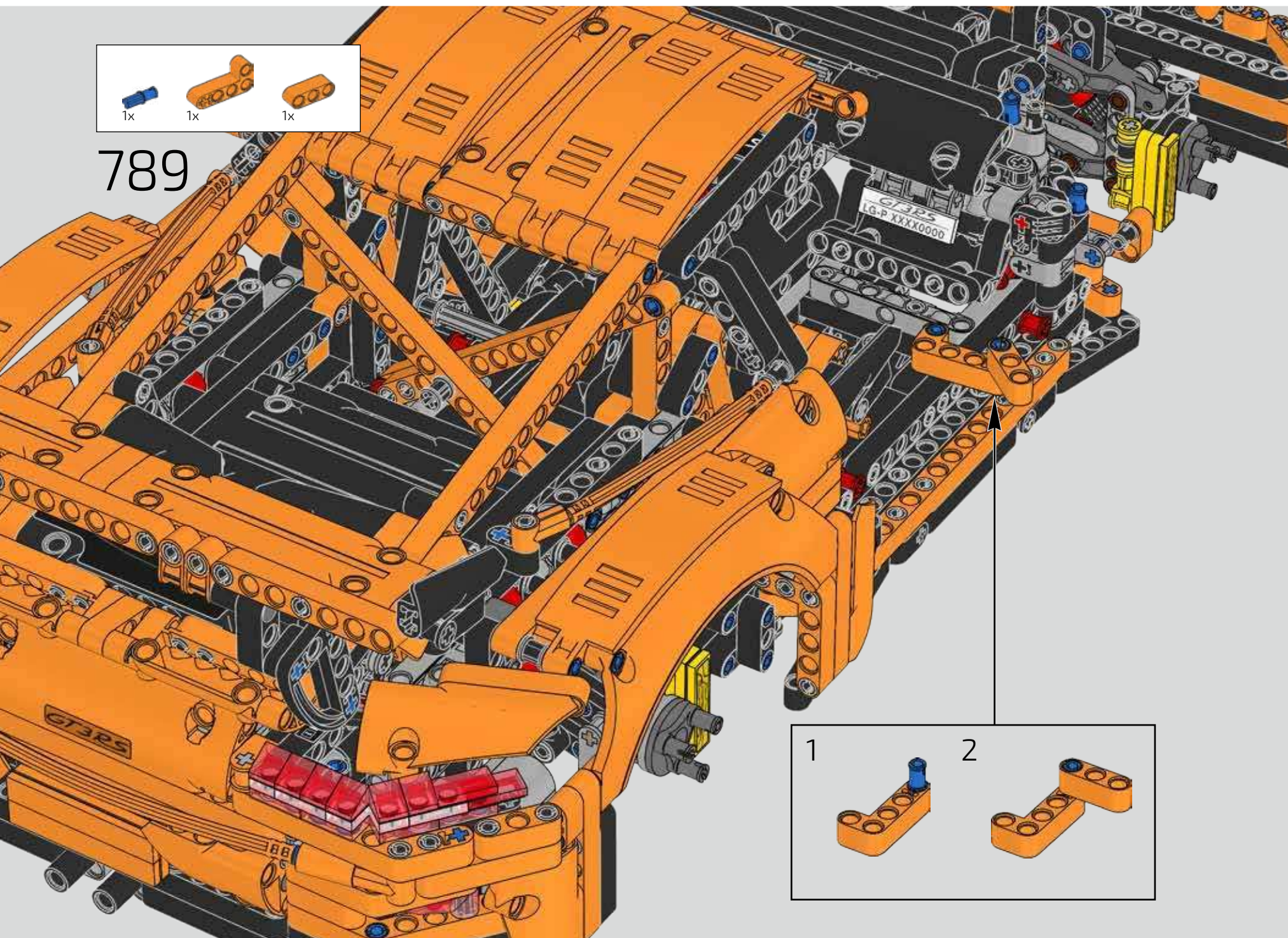

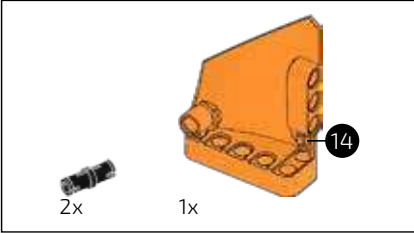
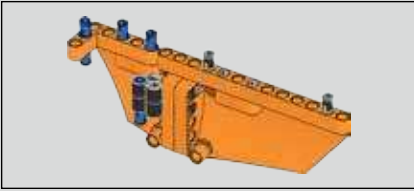

790

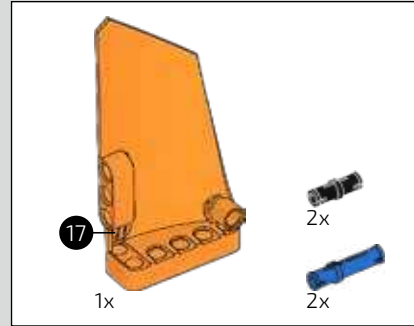
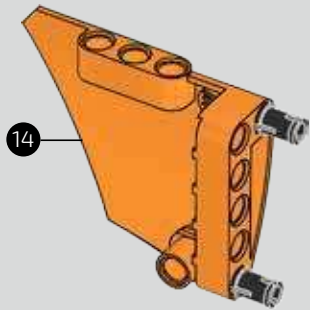

791

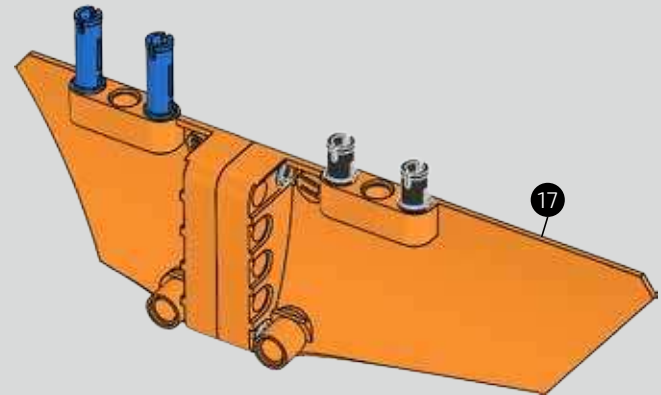

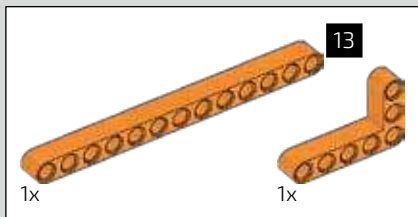

792

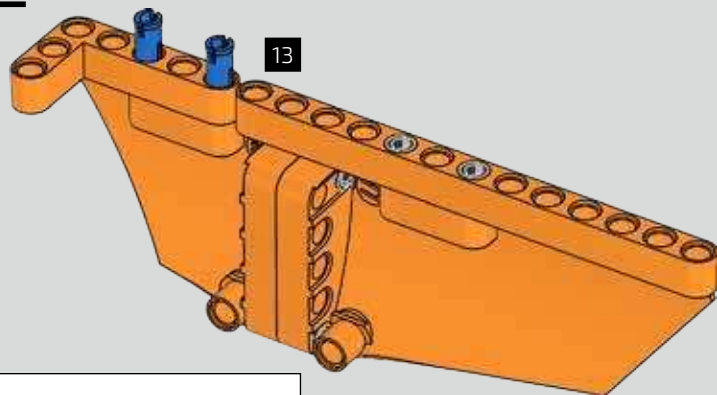

793

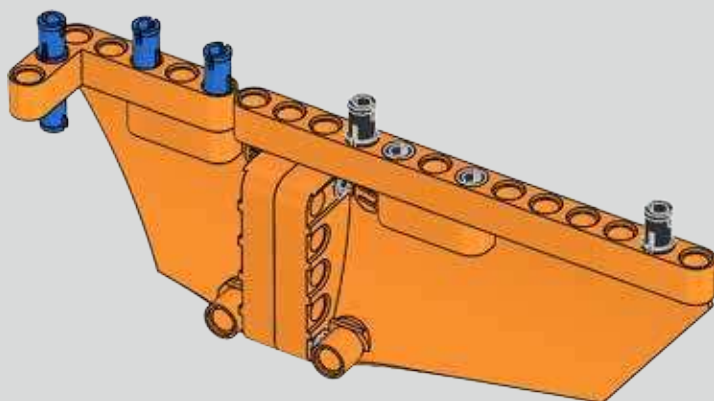

794

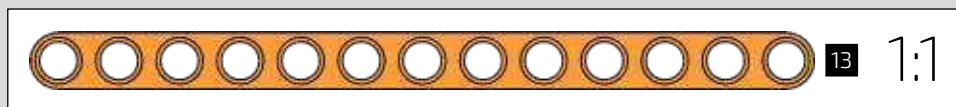
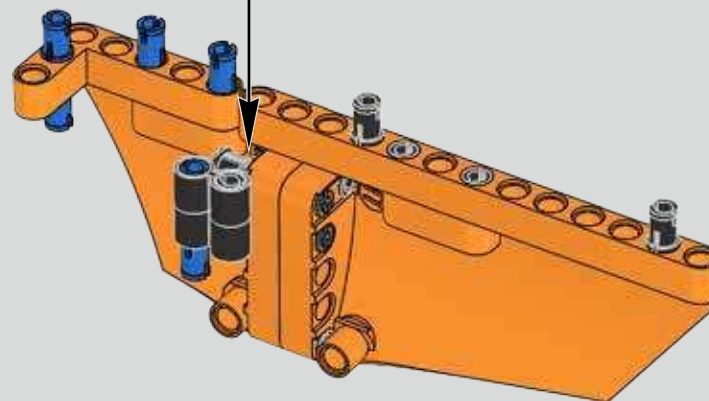
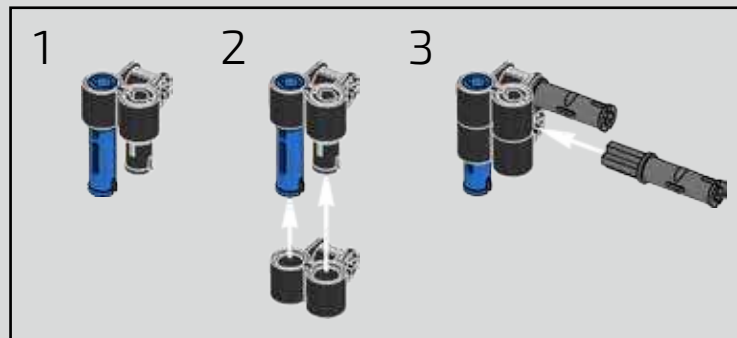

795

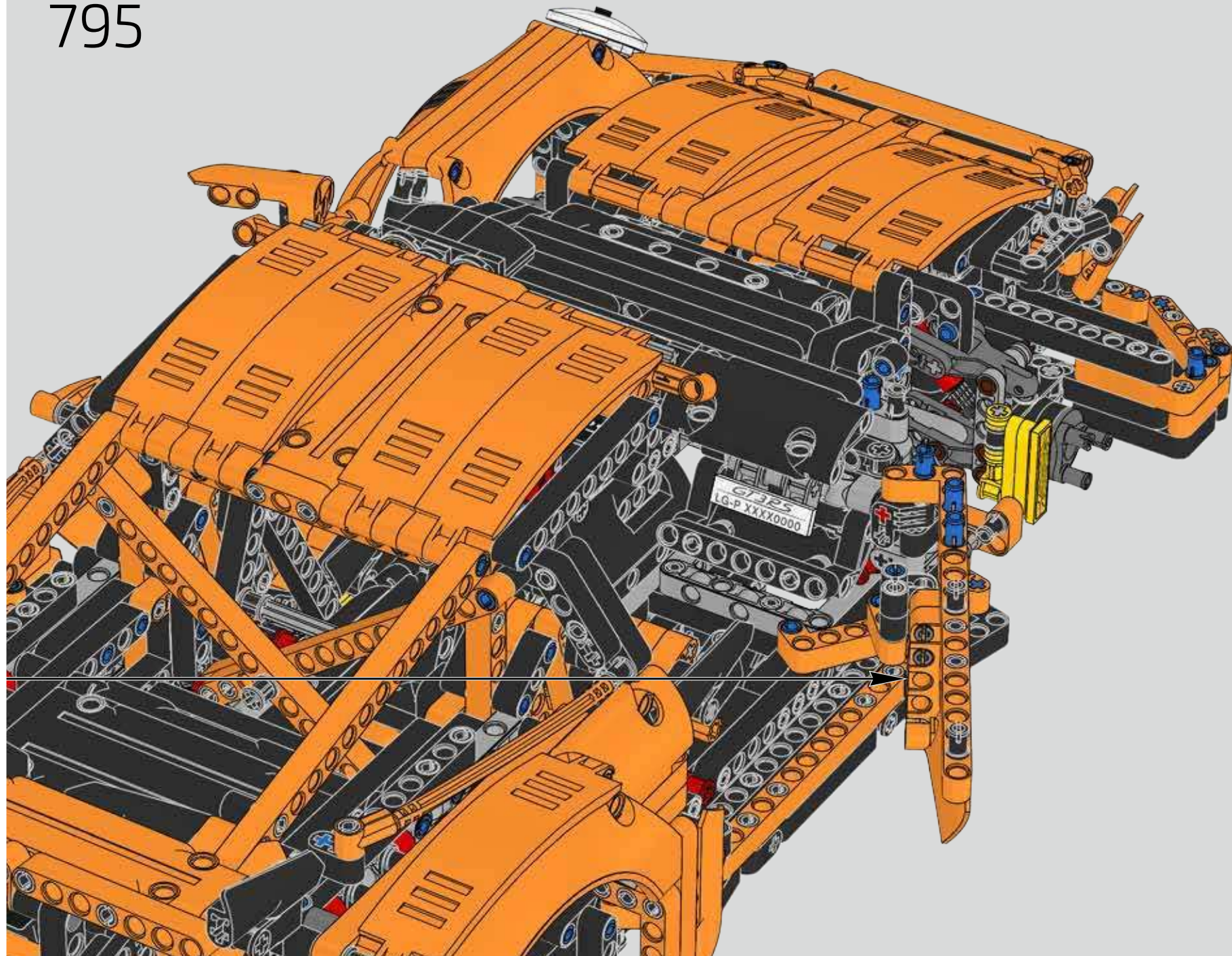

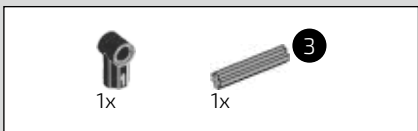

796



797

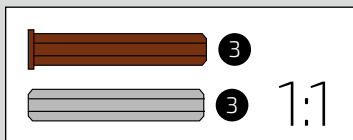

798

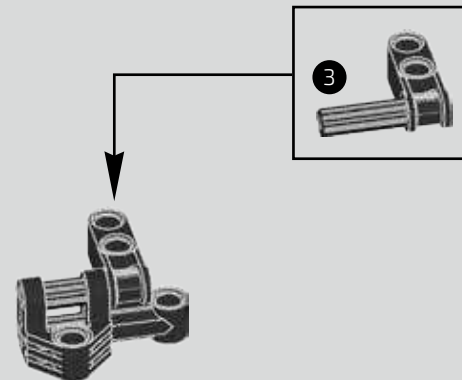

799

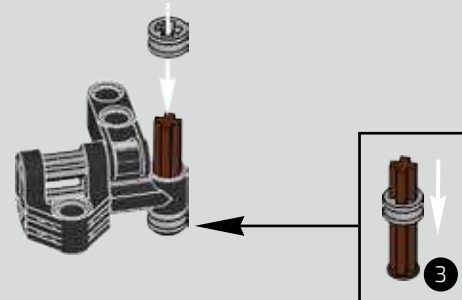

800

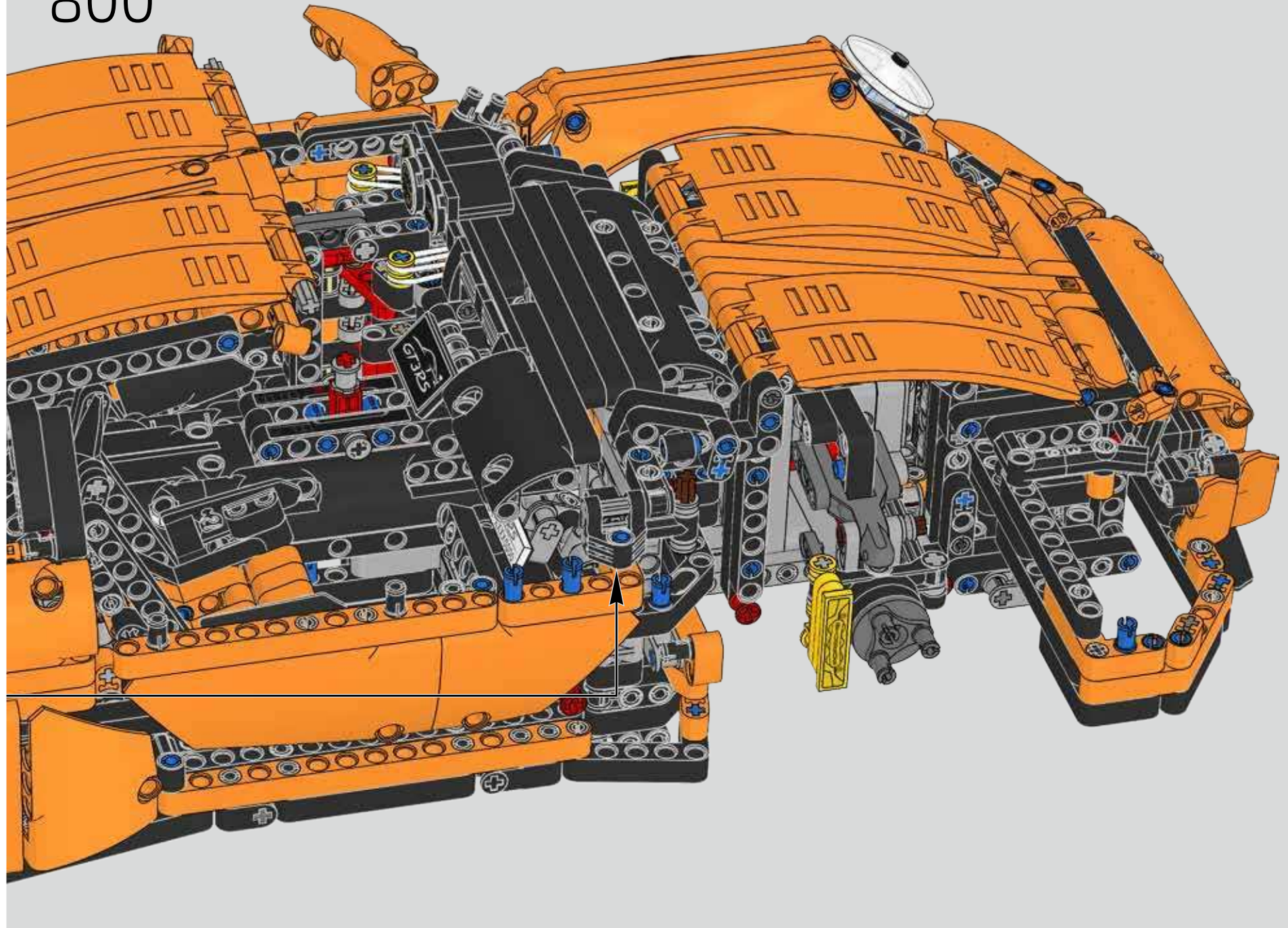

801

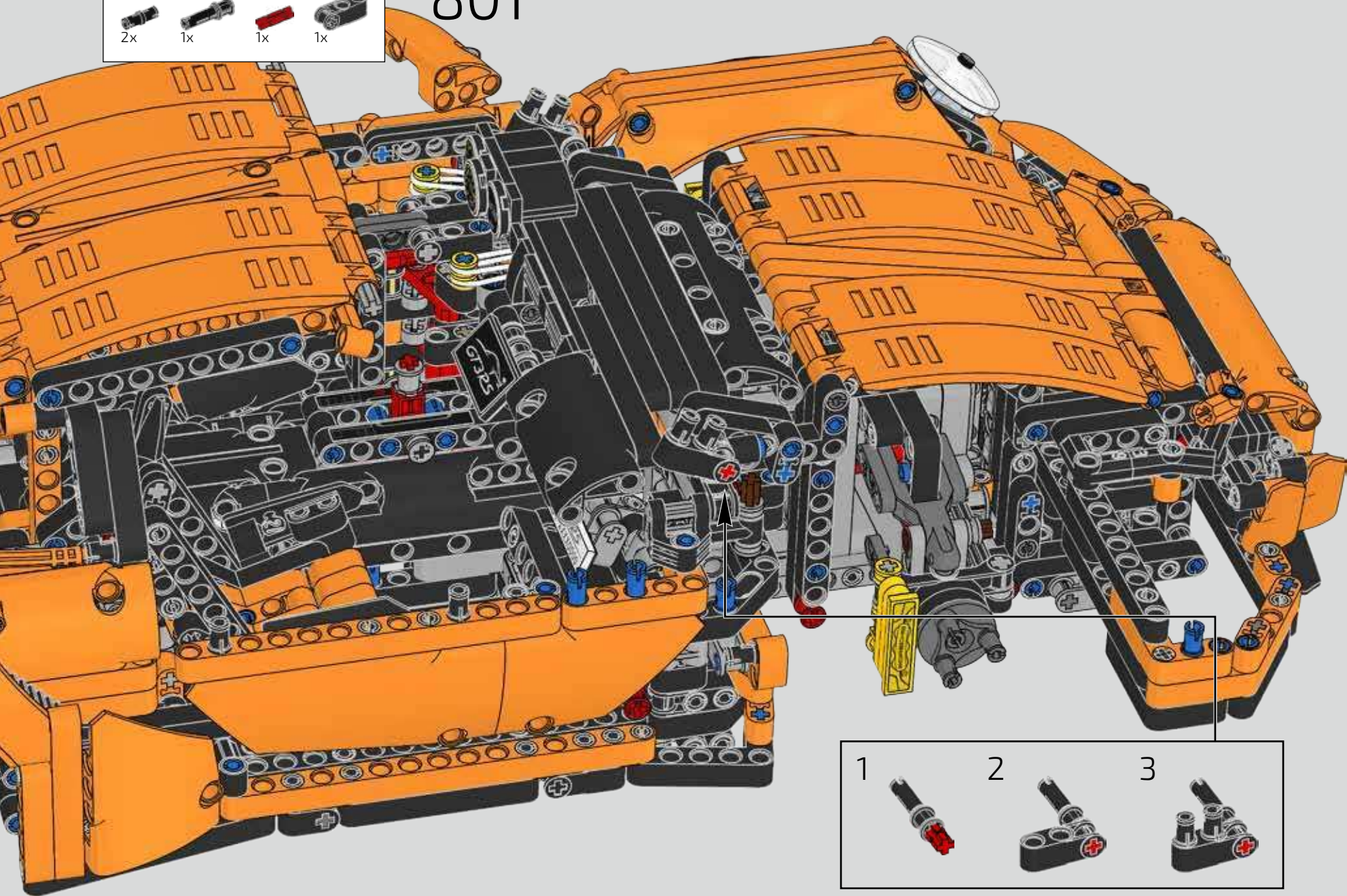



802

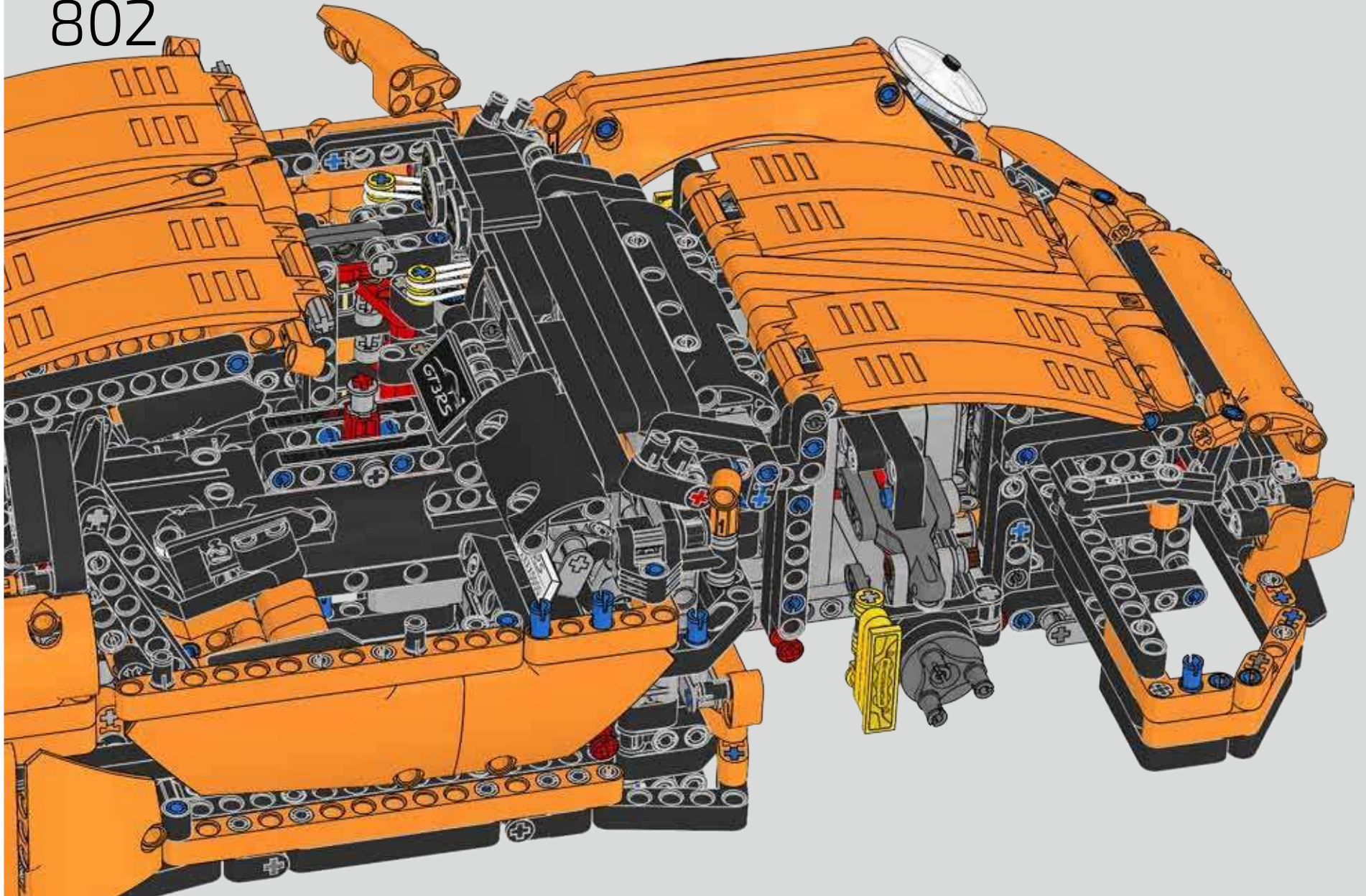

803

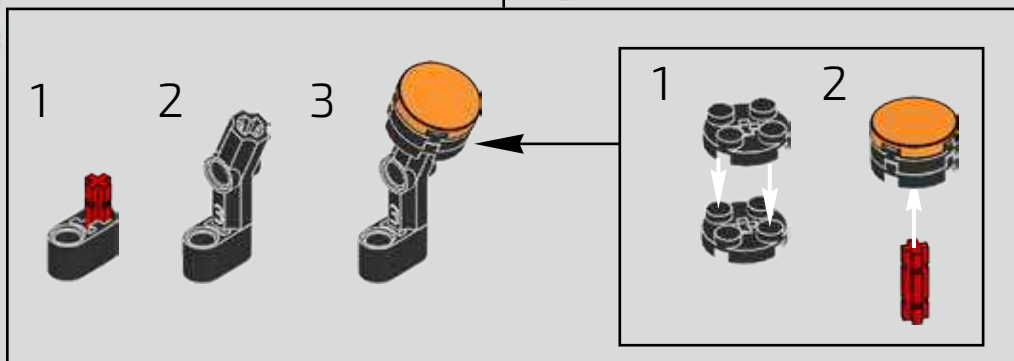
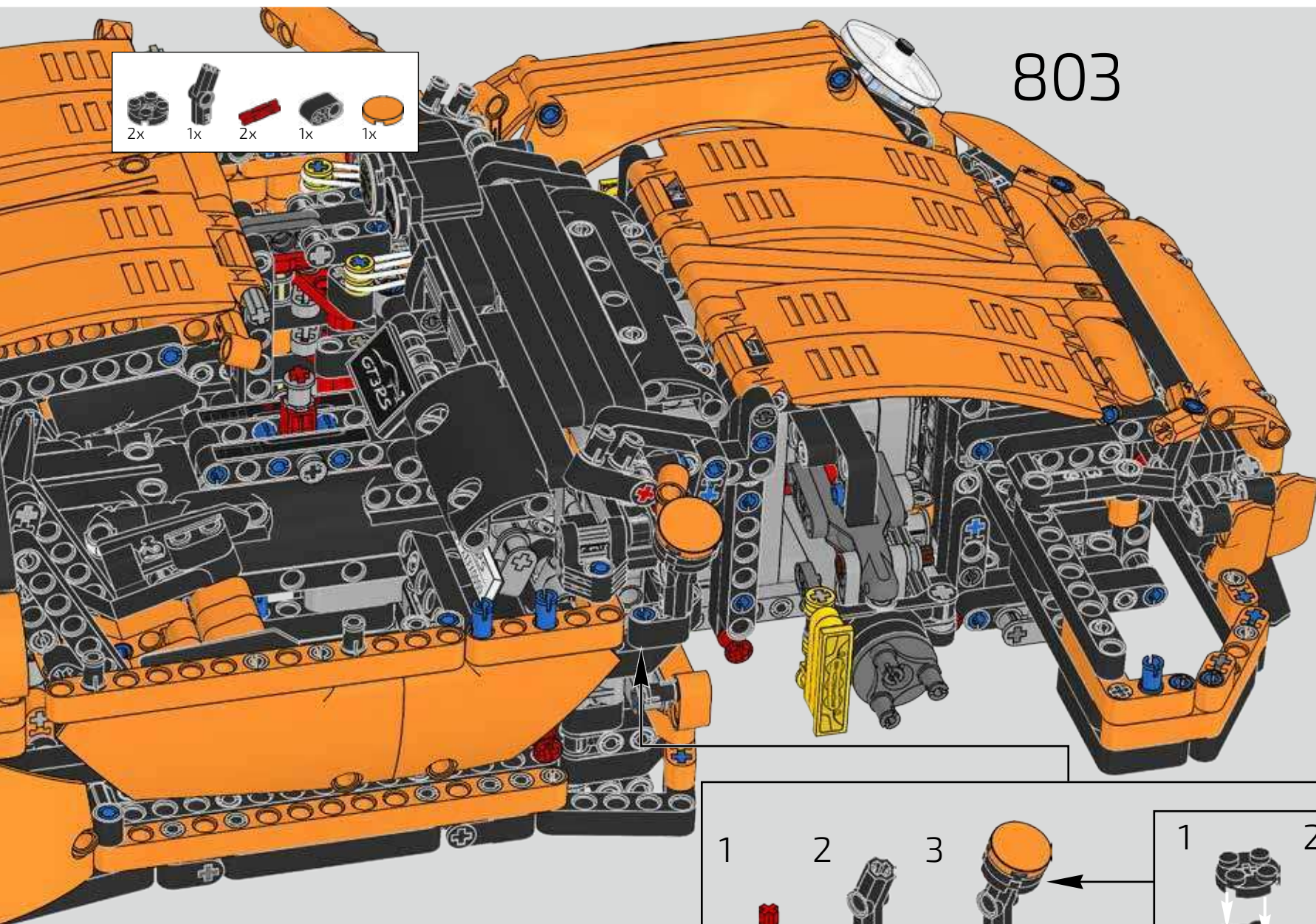

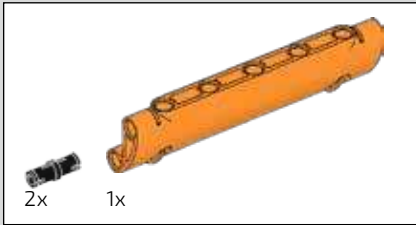
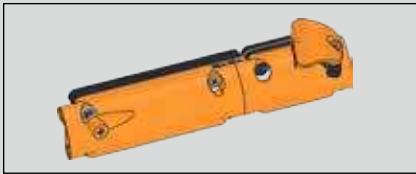

804

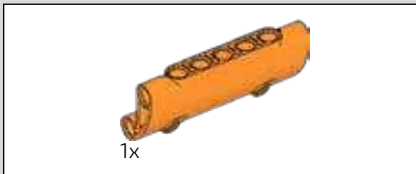
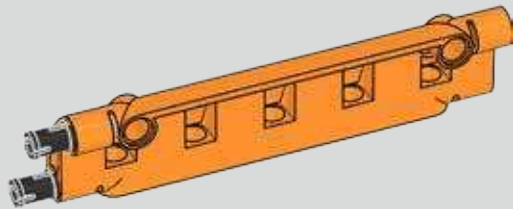

805

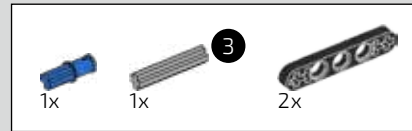
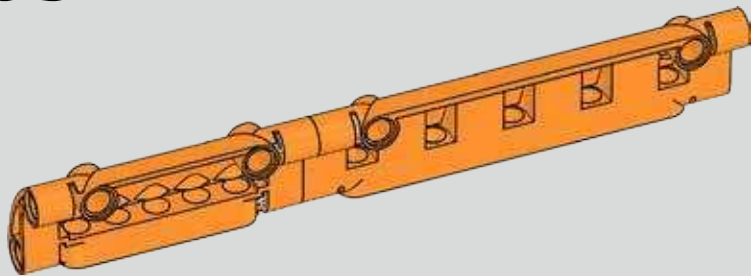

806

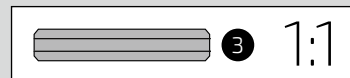
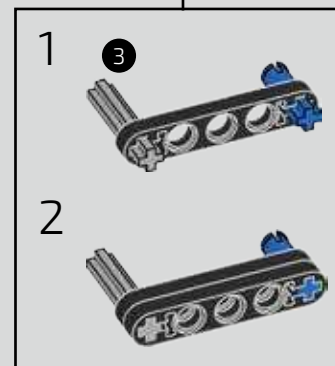
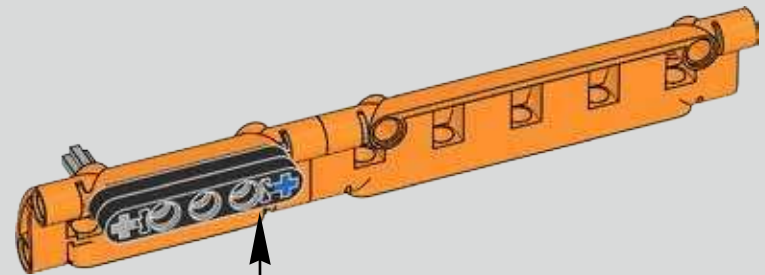

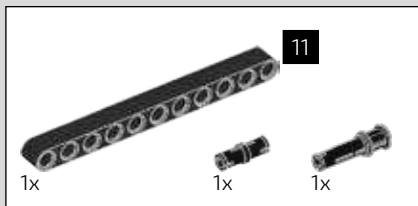

807

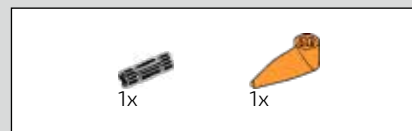
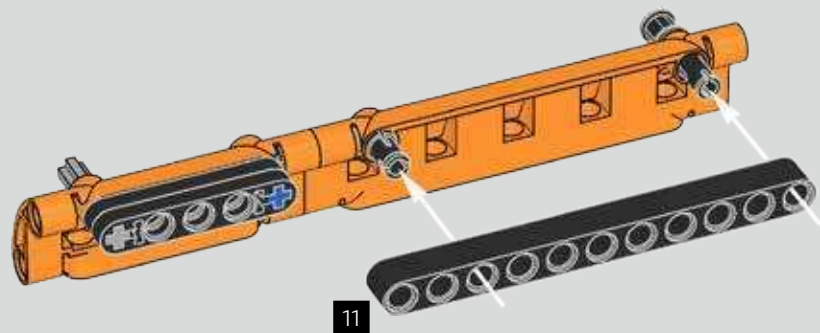

808

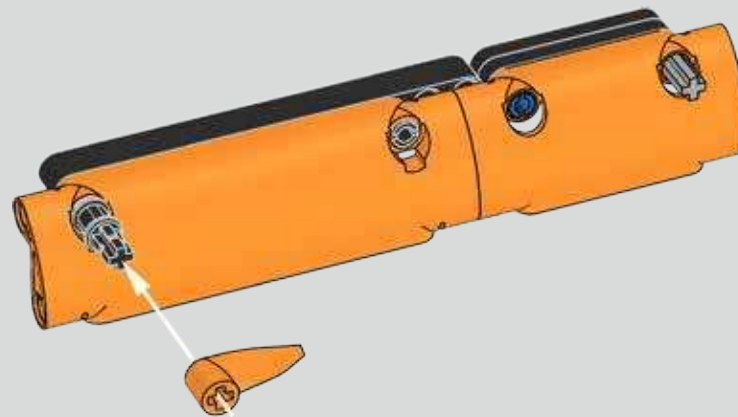
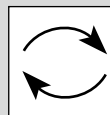

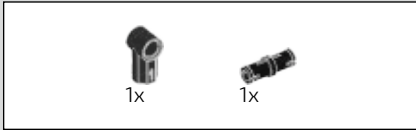

809

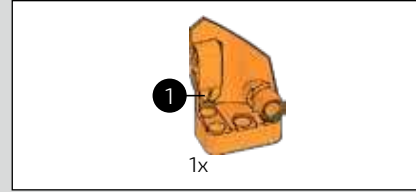
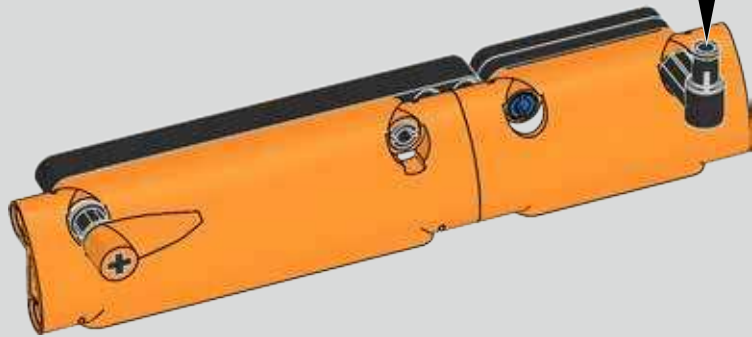
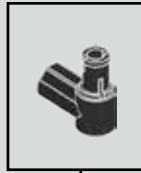

810



811

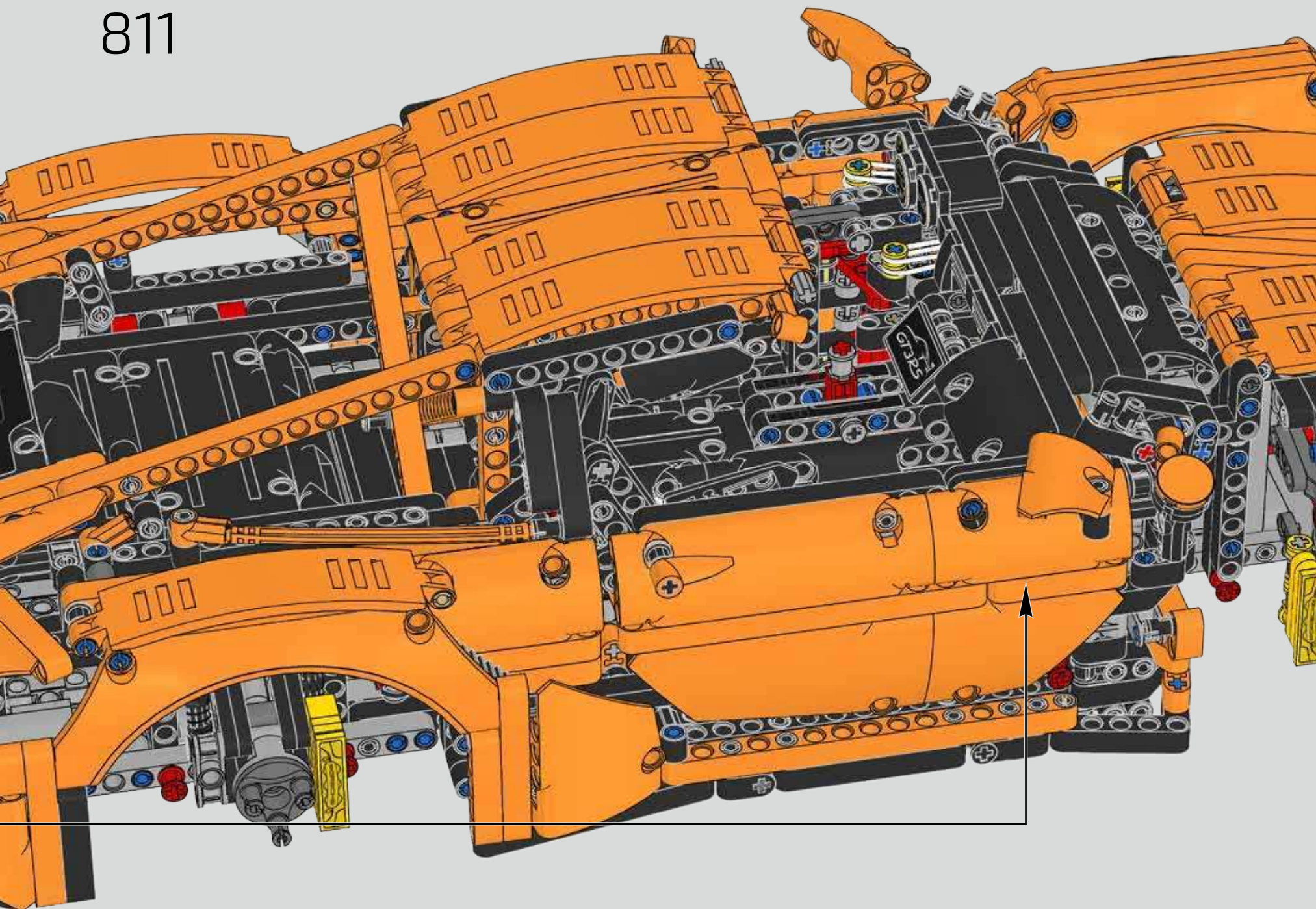

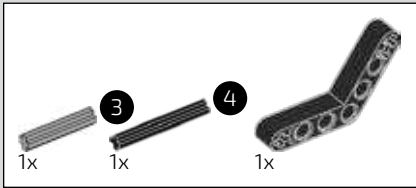
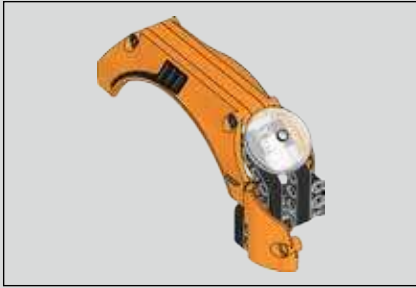

812

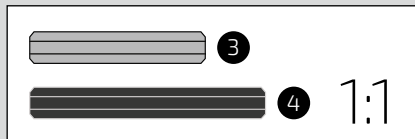
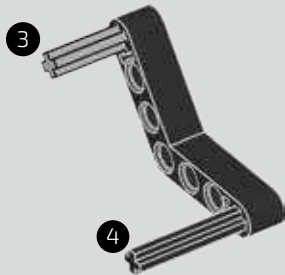

813

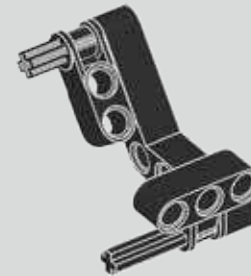

814





815



816

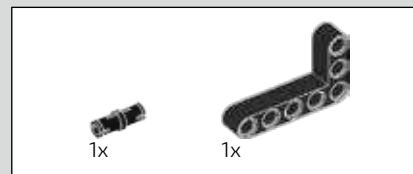

817

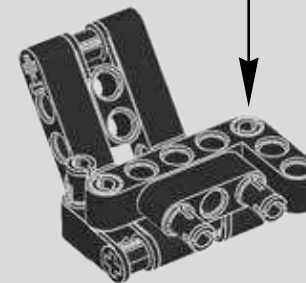
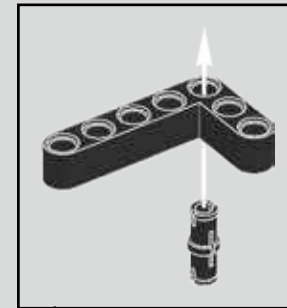

818

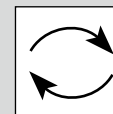

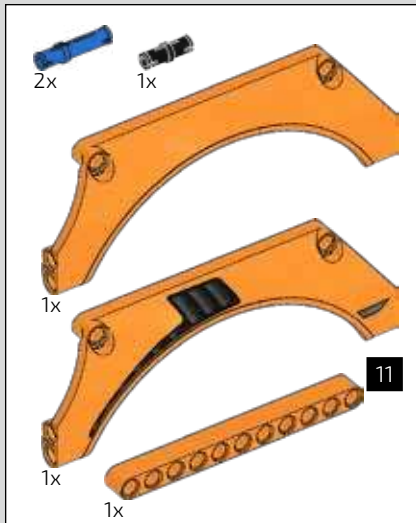

819

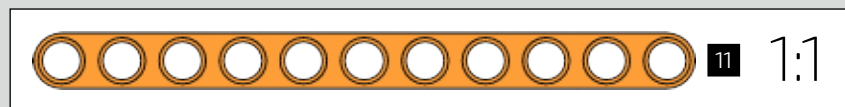
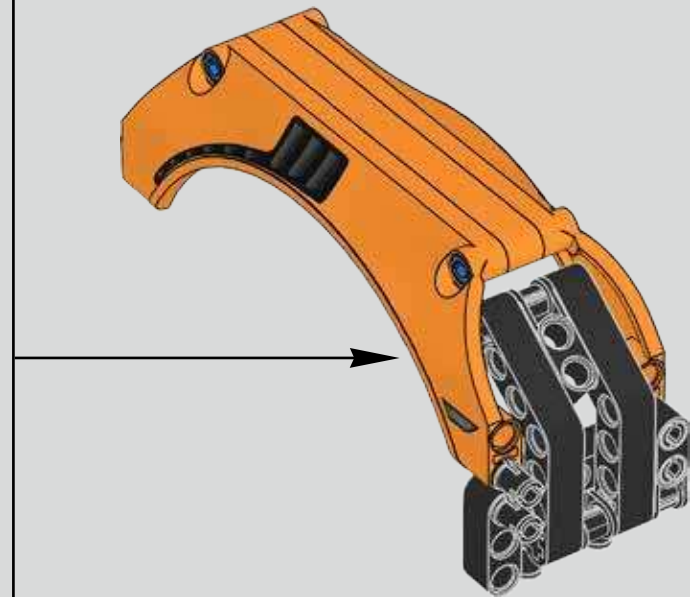
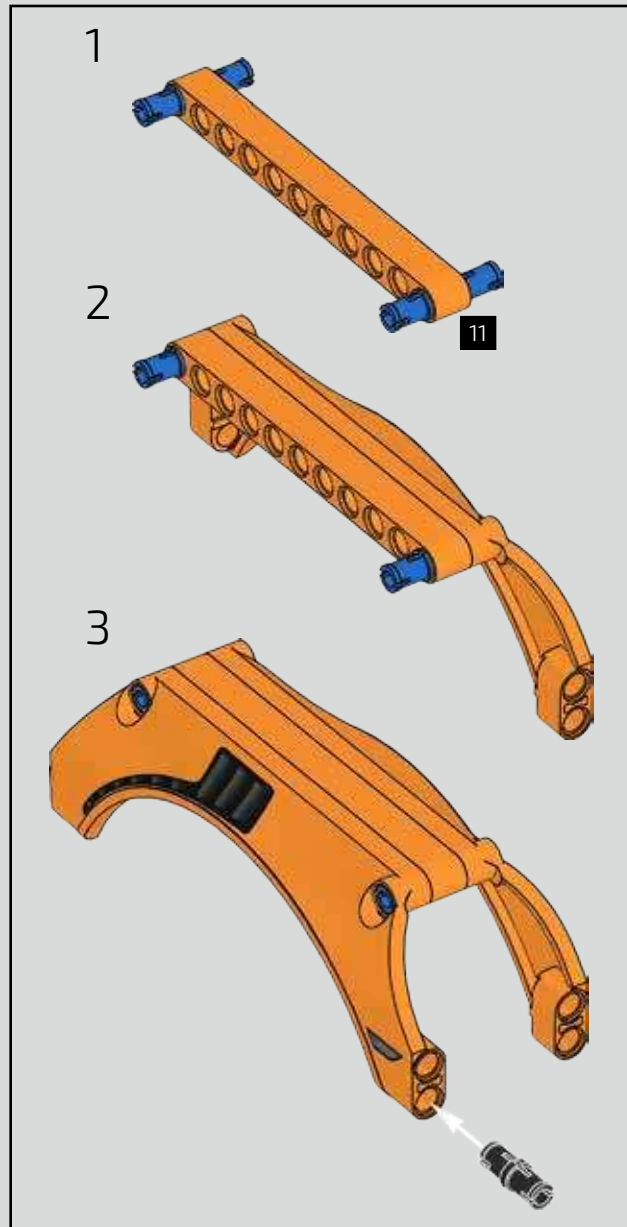

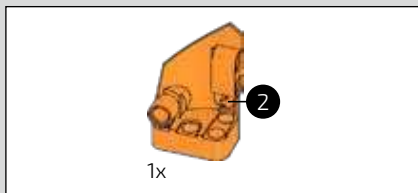

820



821

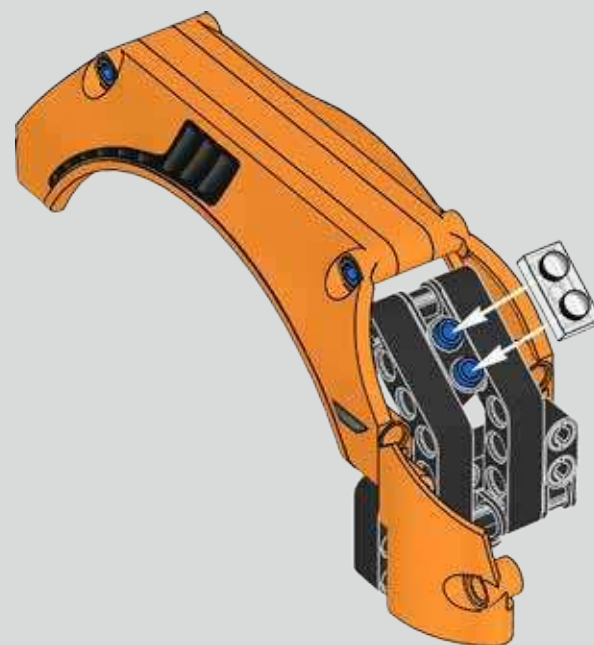

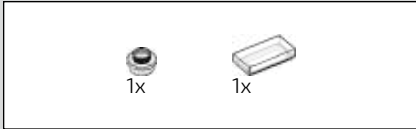

822

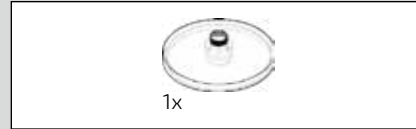

823



824

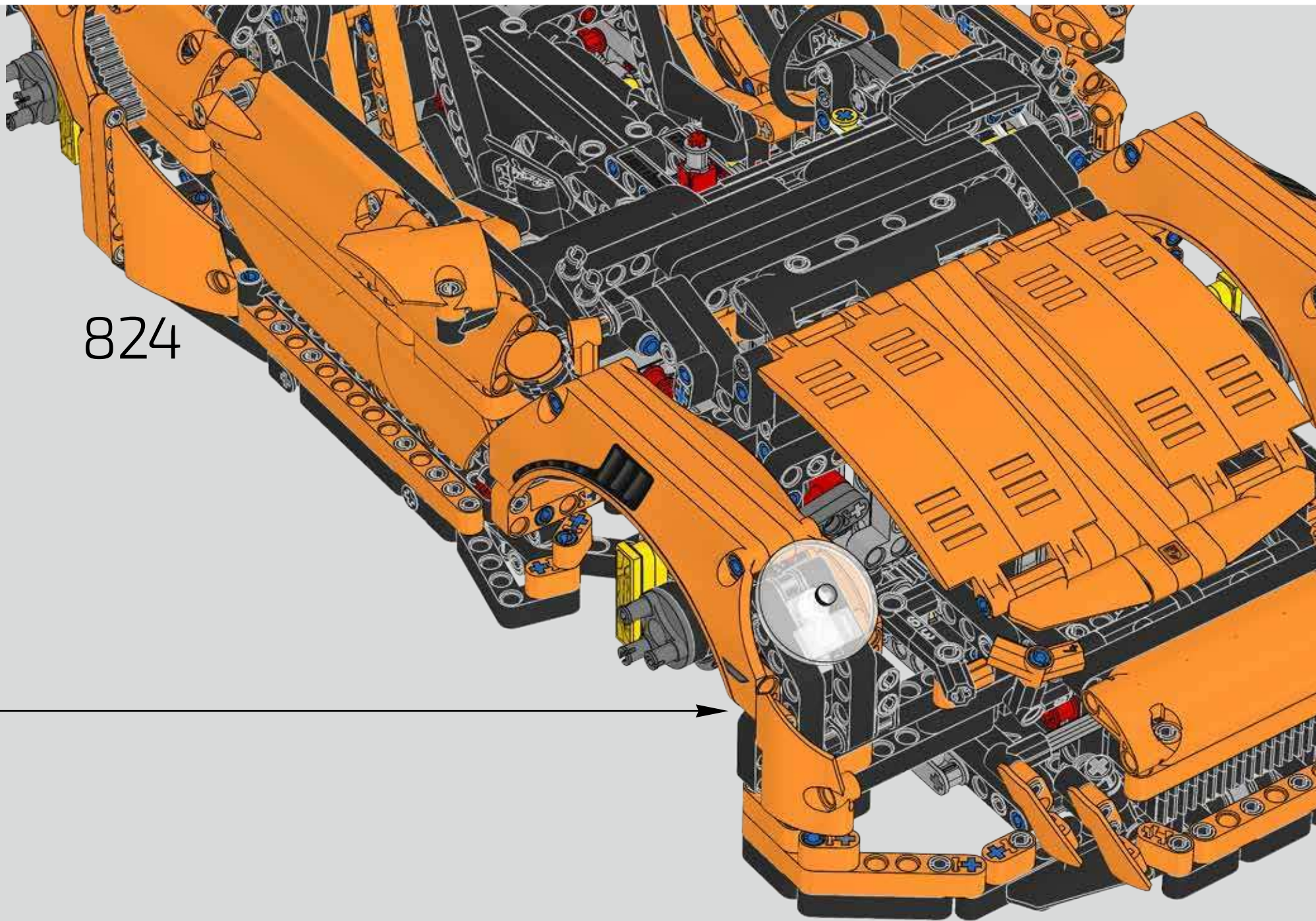

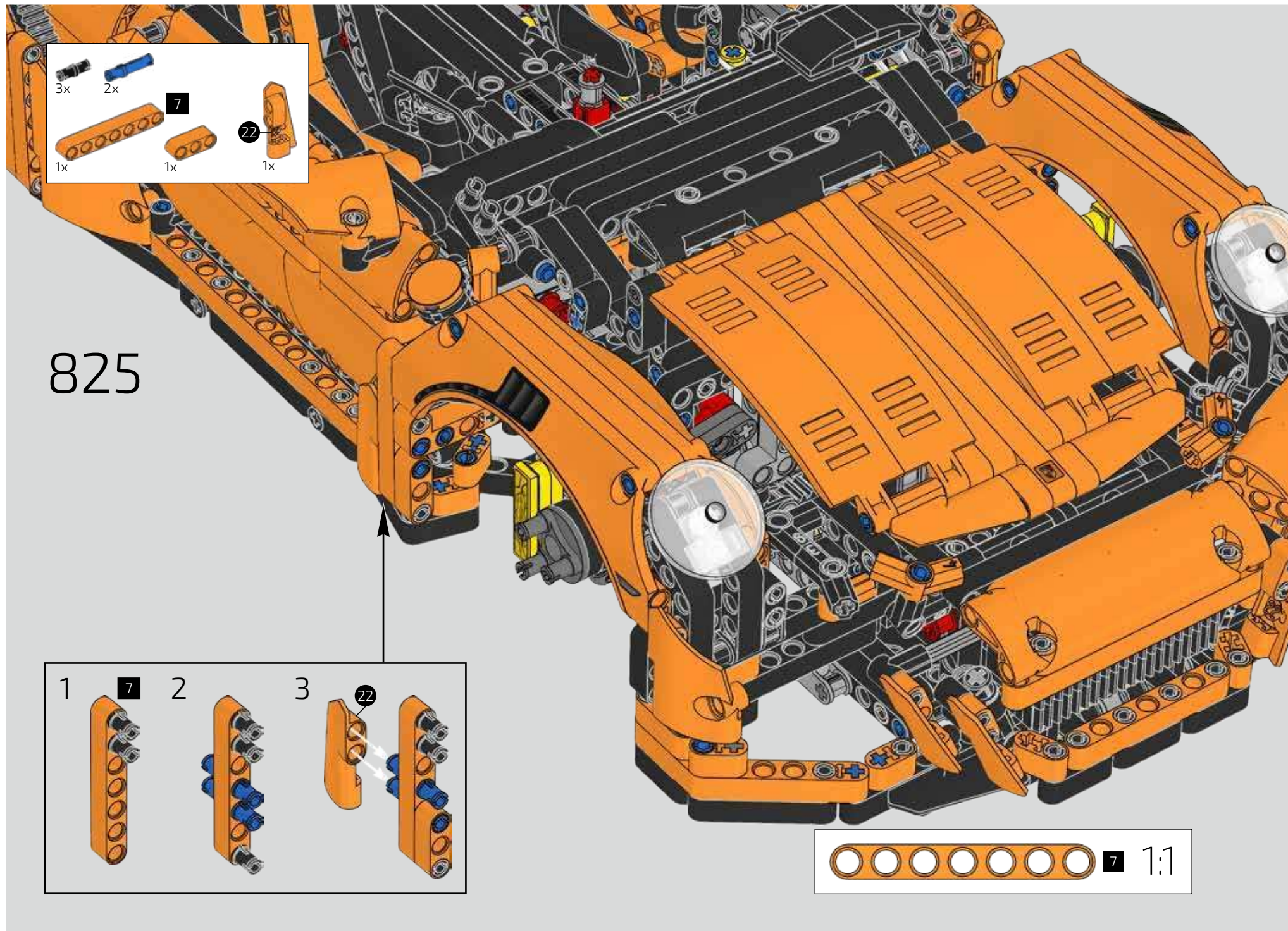

3x 2x

7

1x 1x 1x

825

1 7 2 3 22

7 1:1

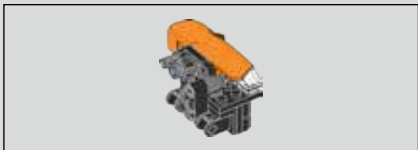

826

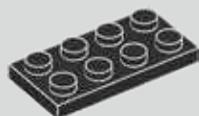

827

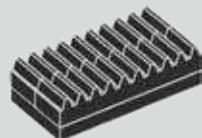

828

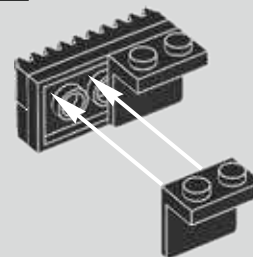

829

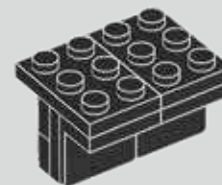

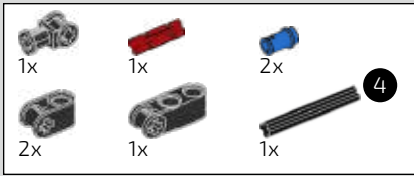

830

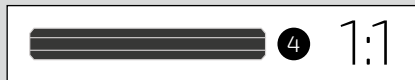
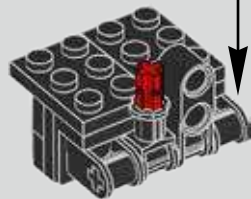
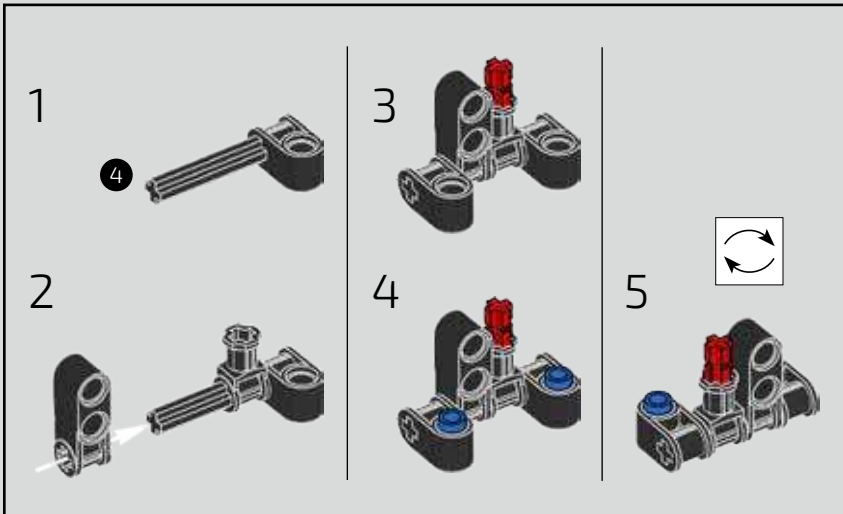

831

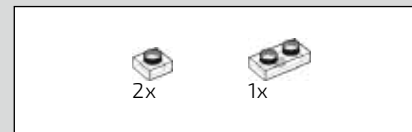
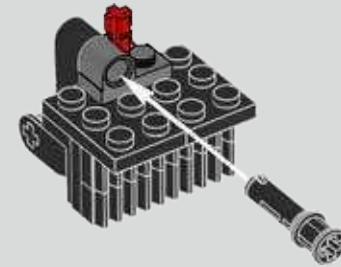
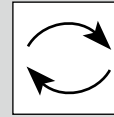

832

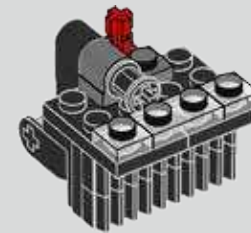

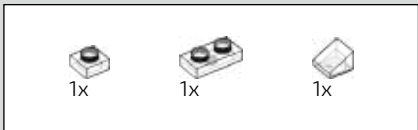

833

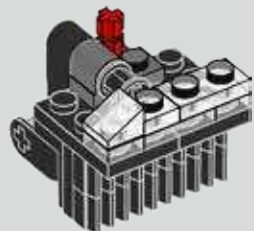

834

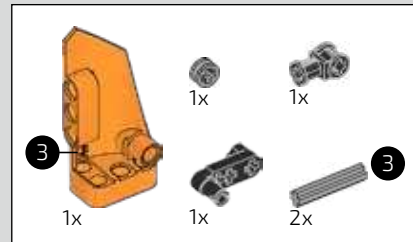
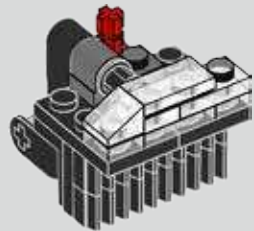

835

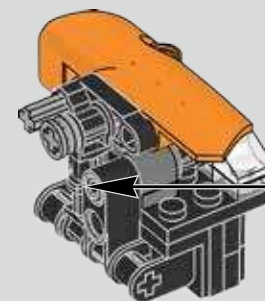
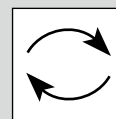
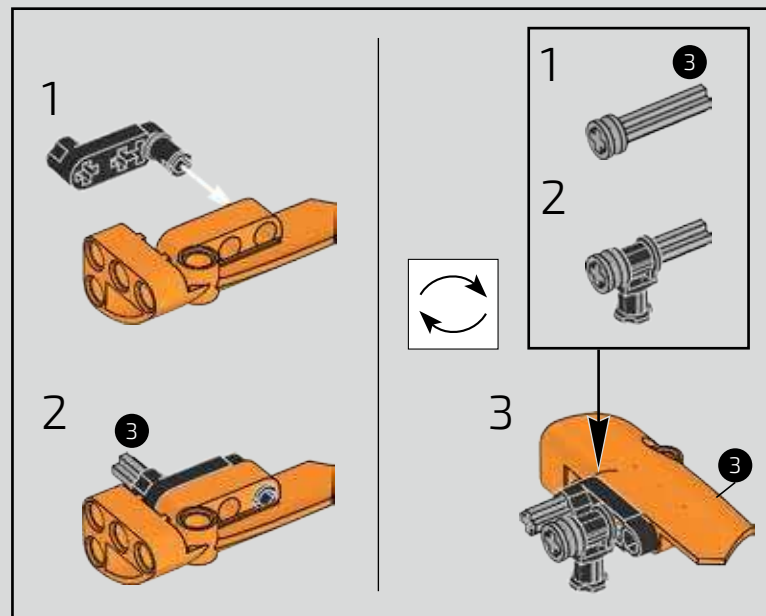
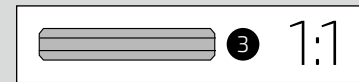

836

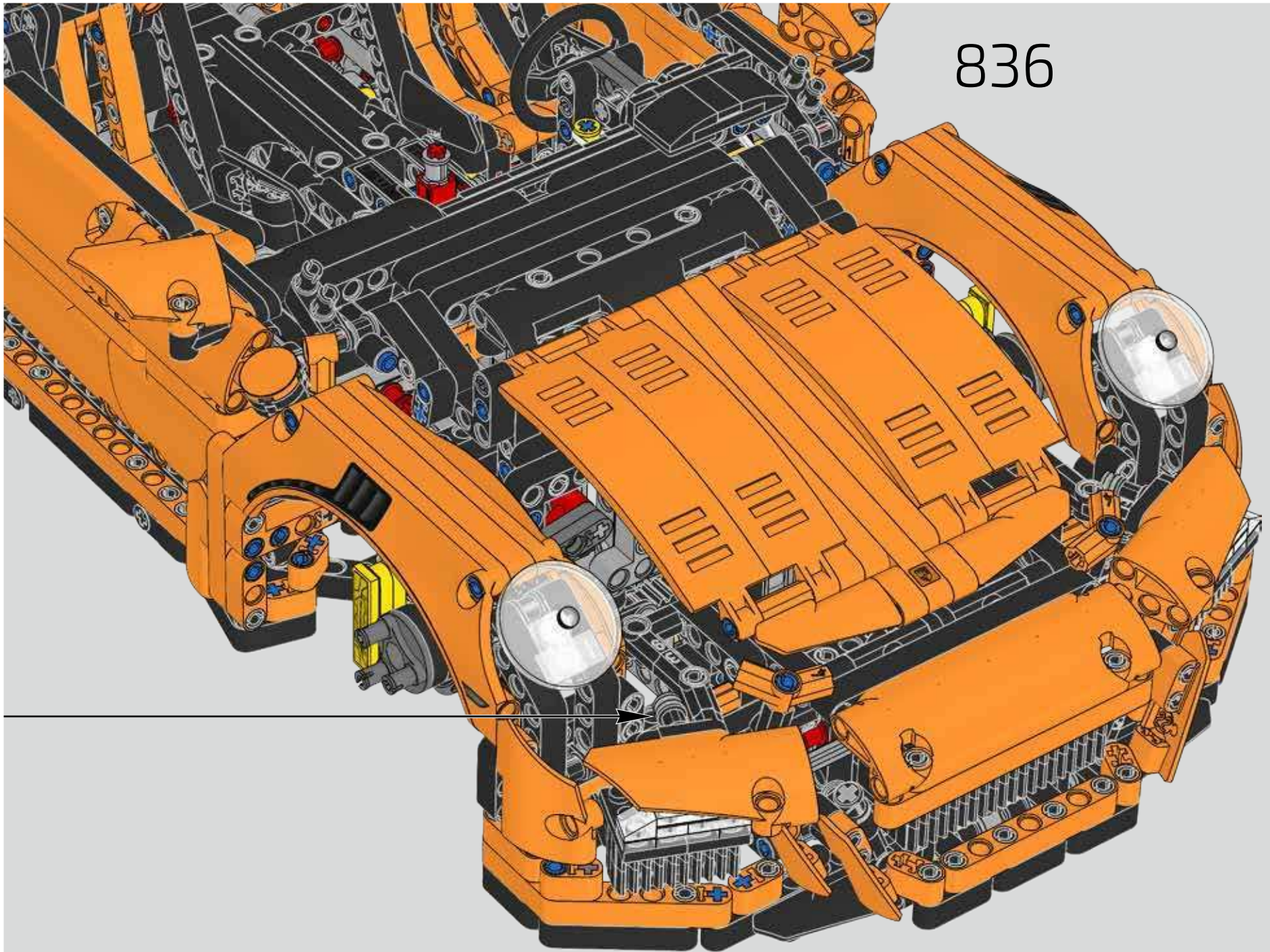

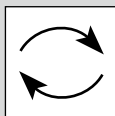
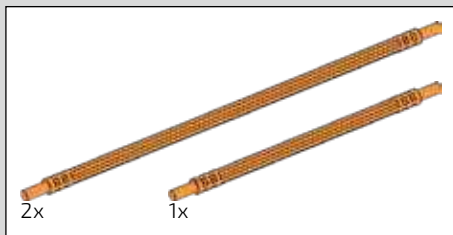

837

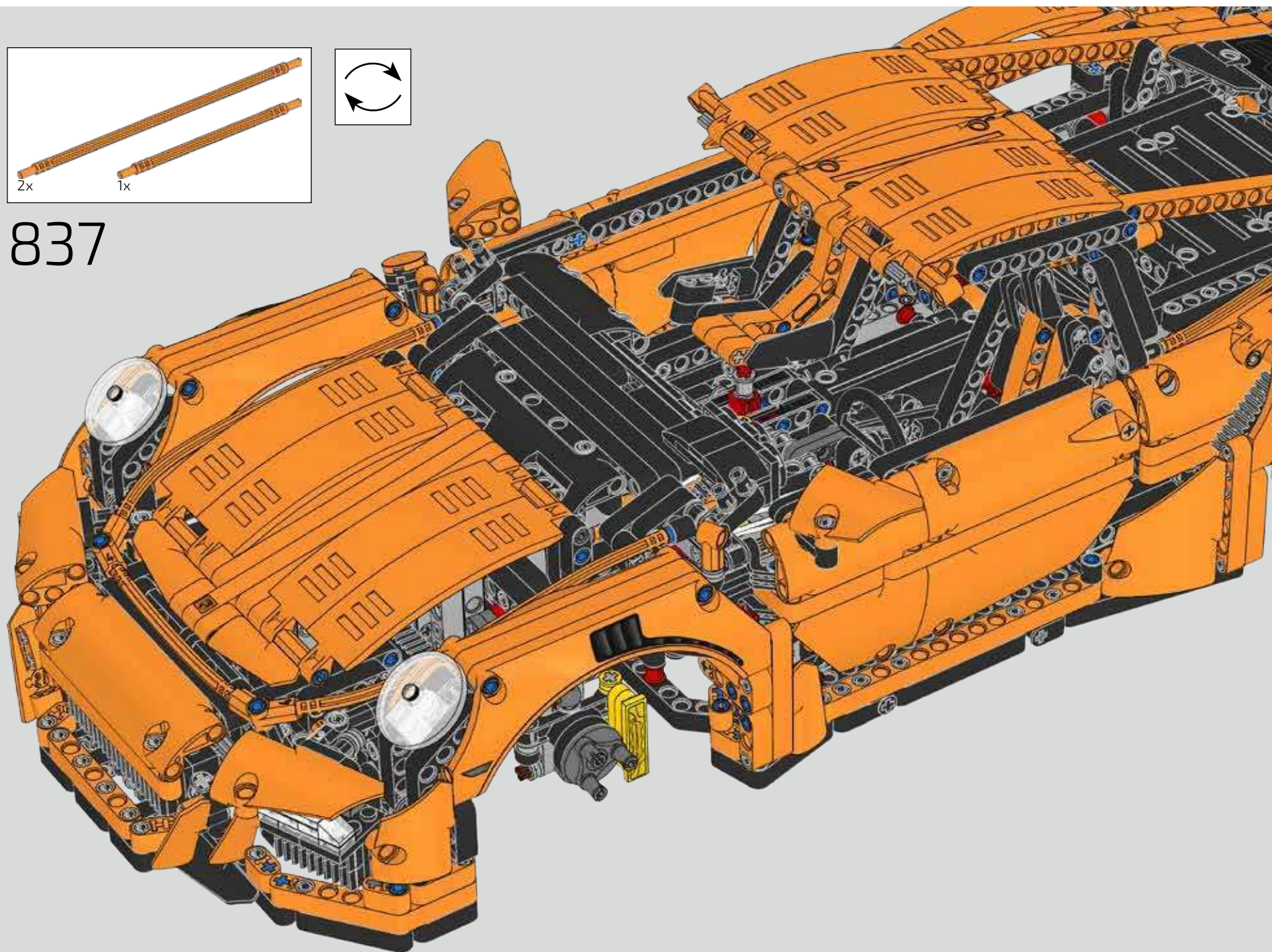

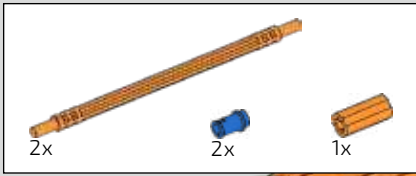

838

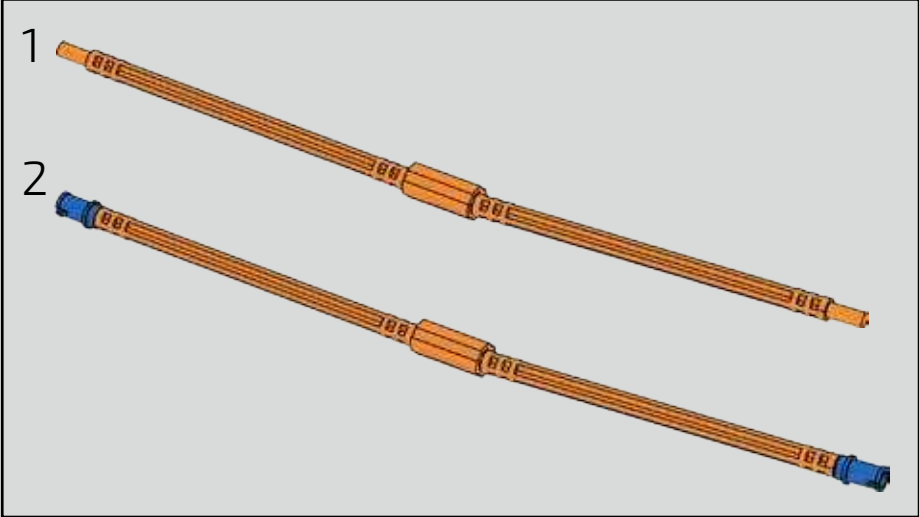
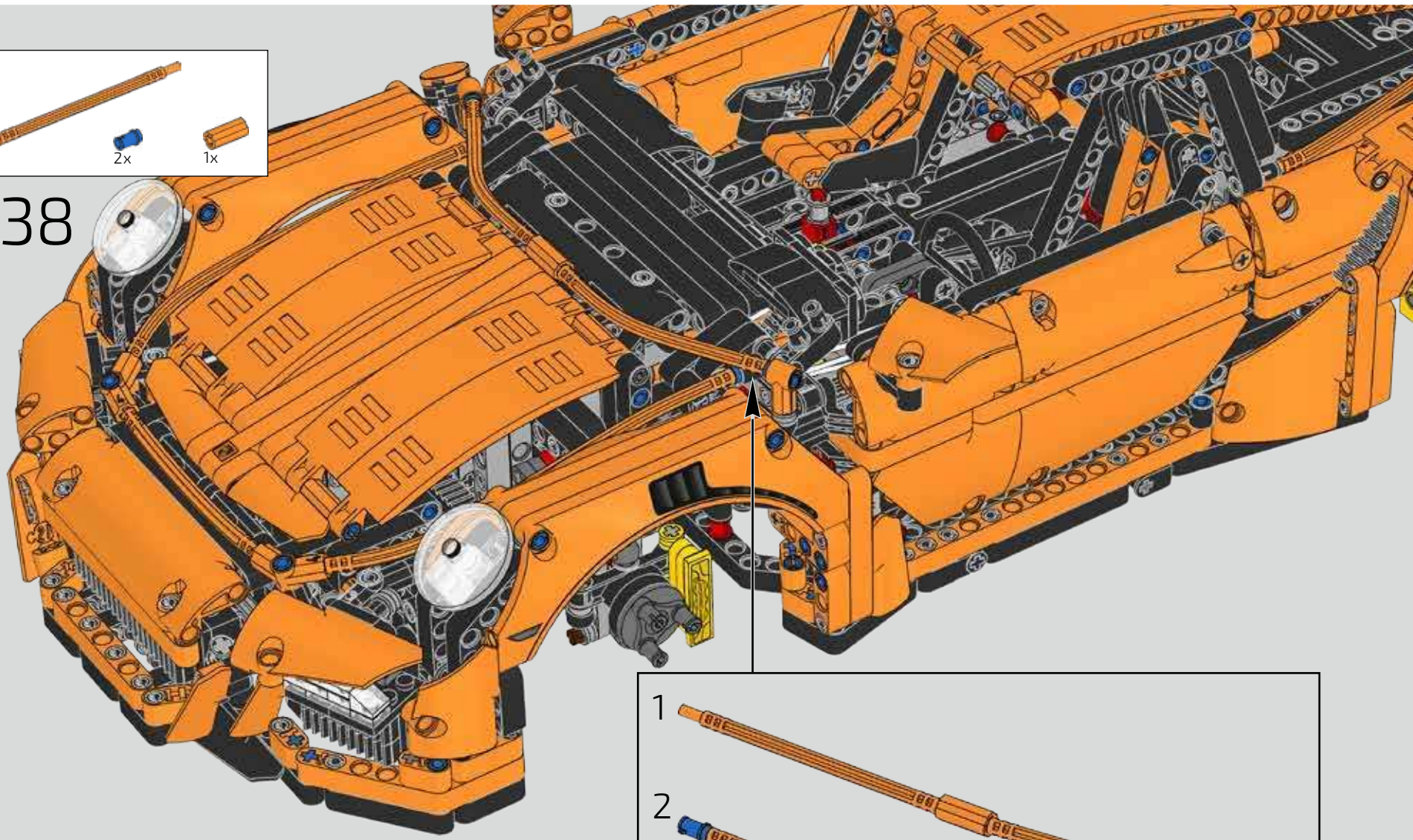

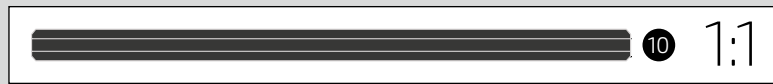
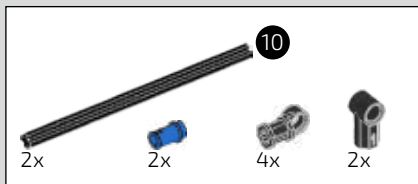

839

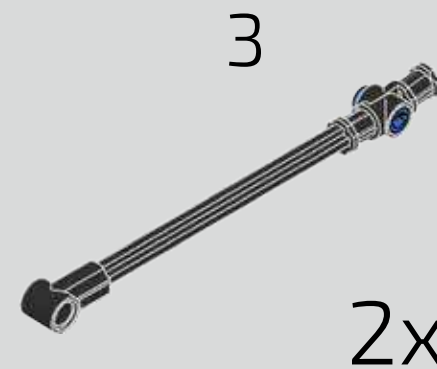
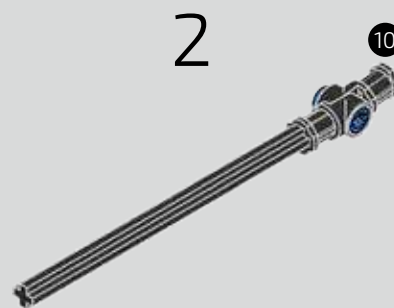
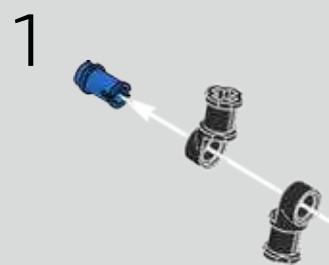

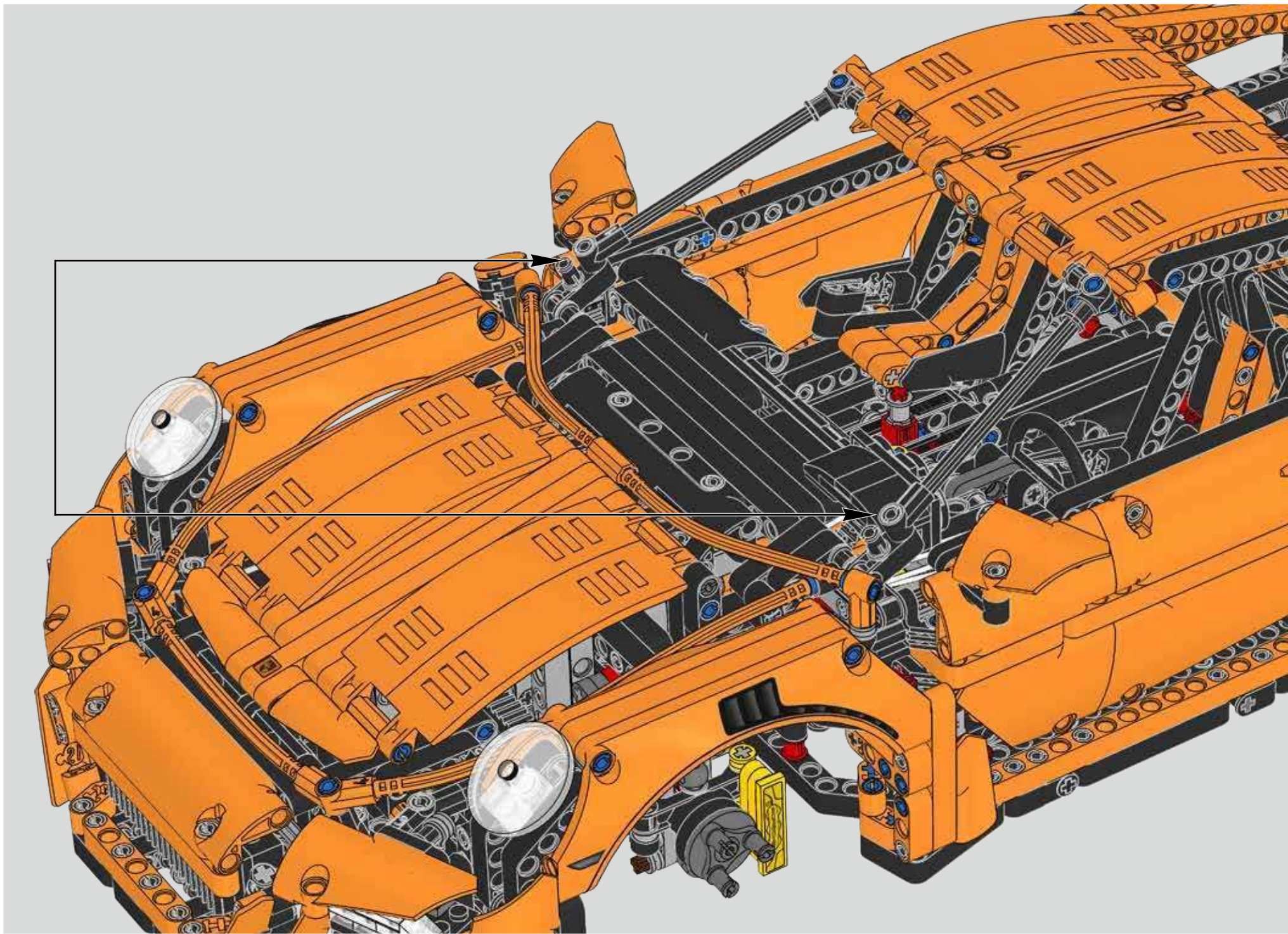

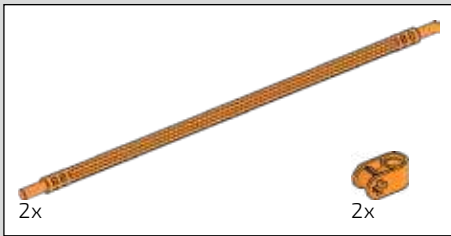

840

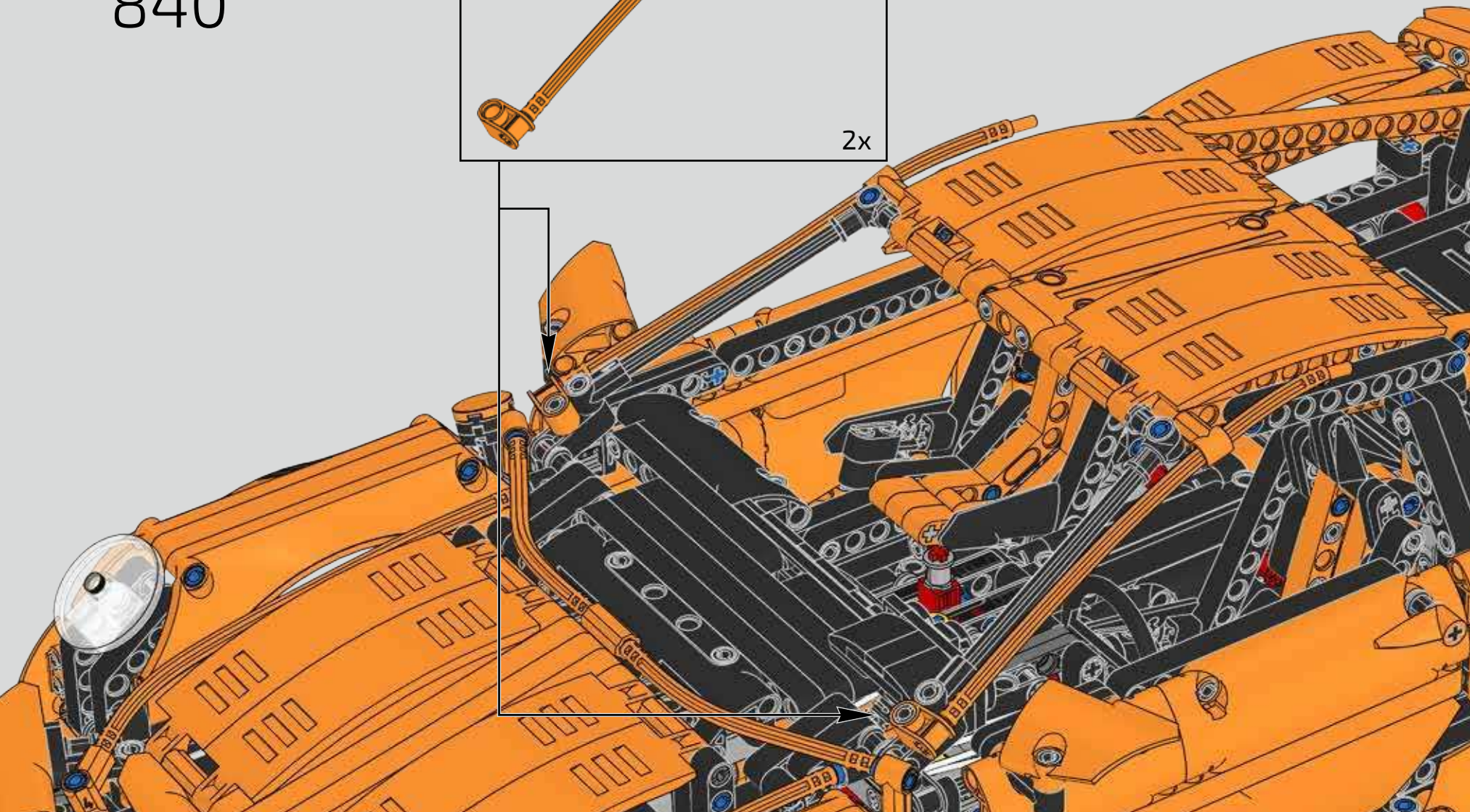
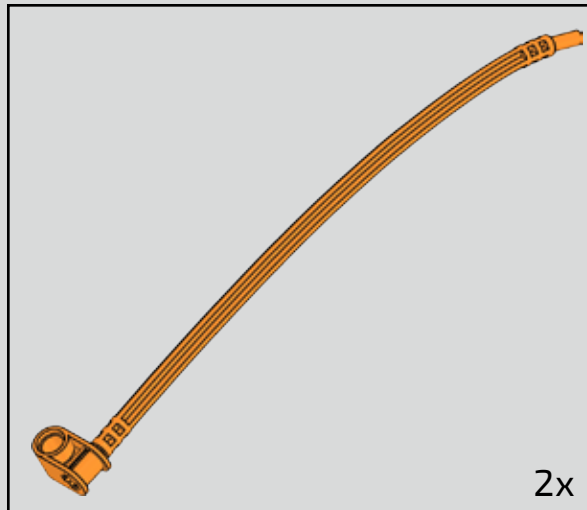

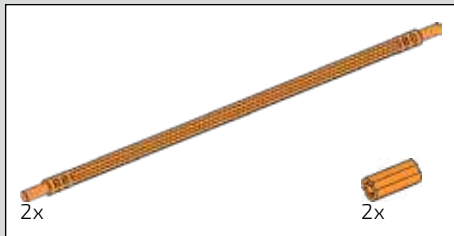

841

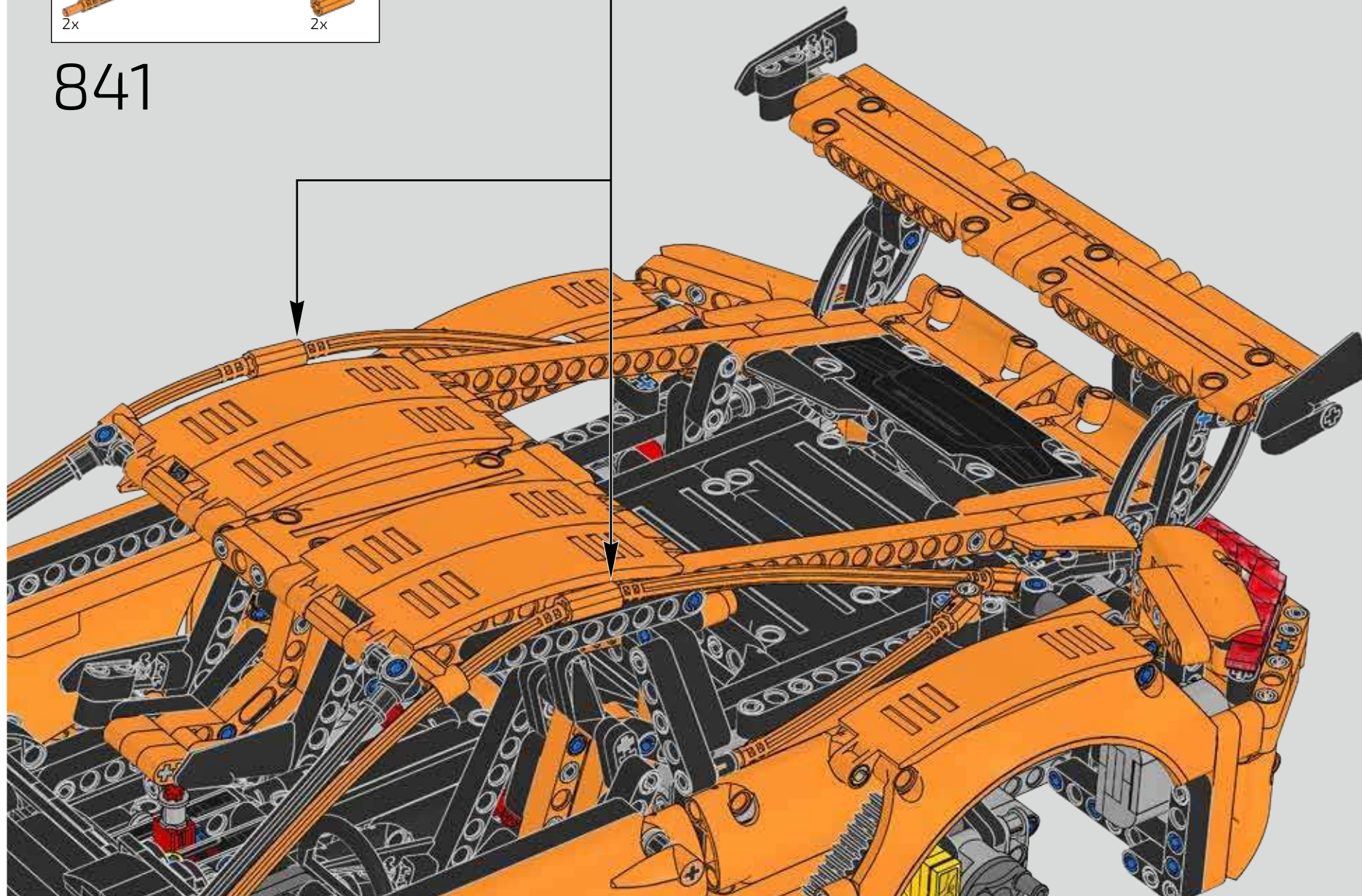



842

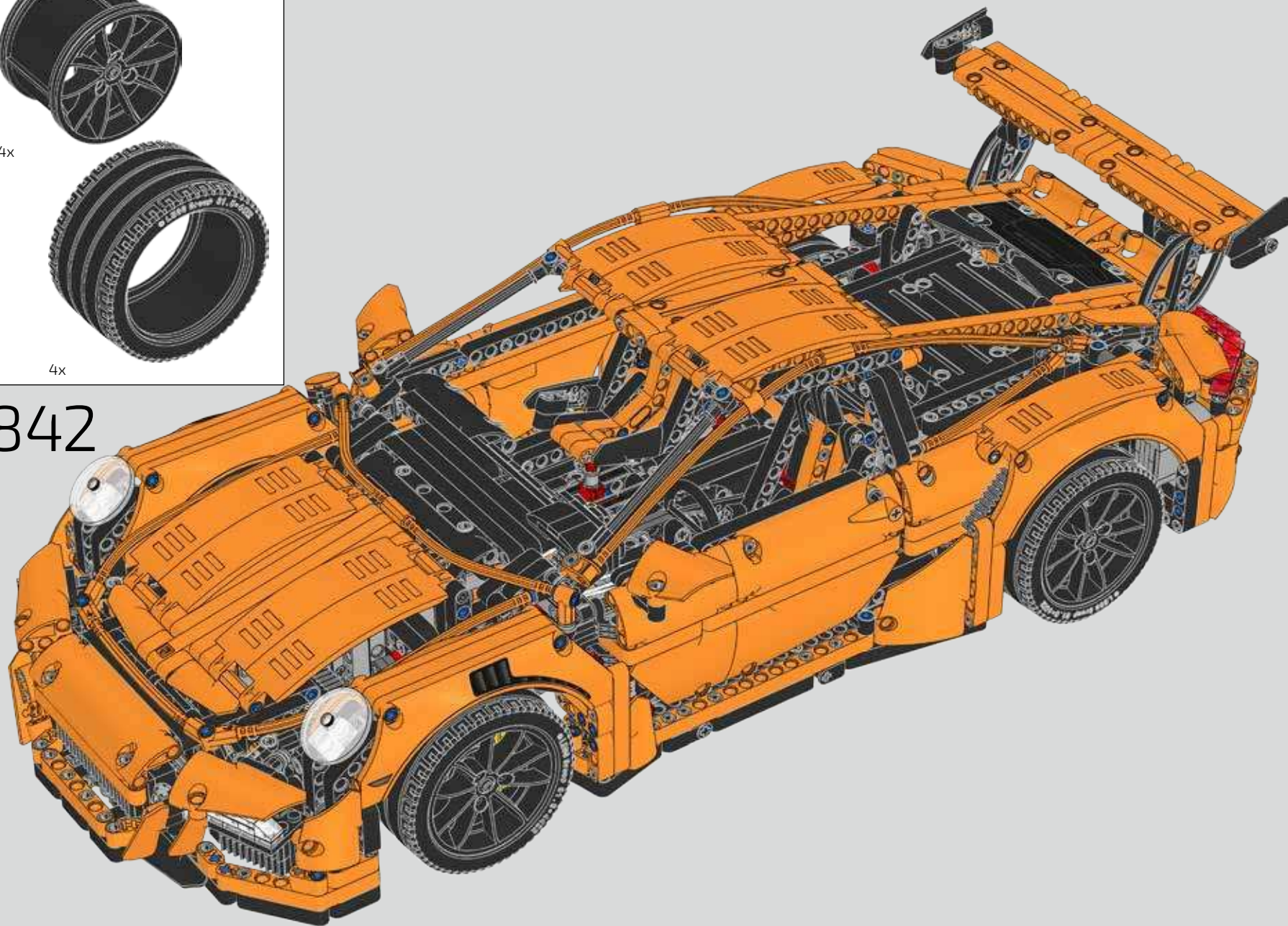

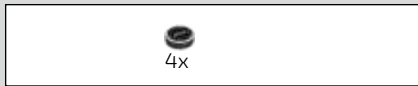

843

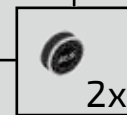
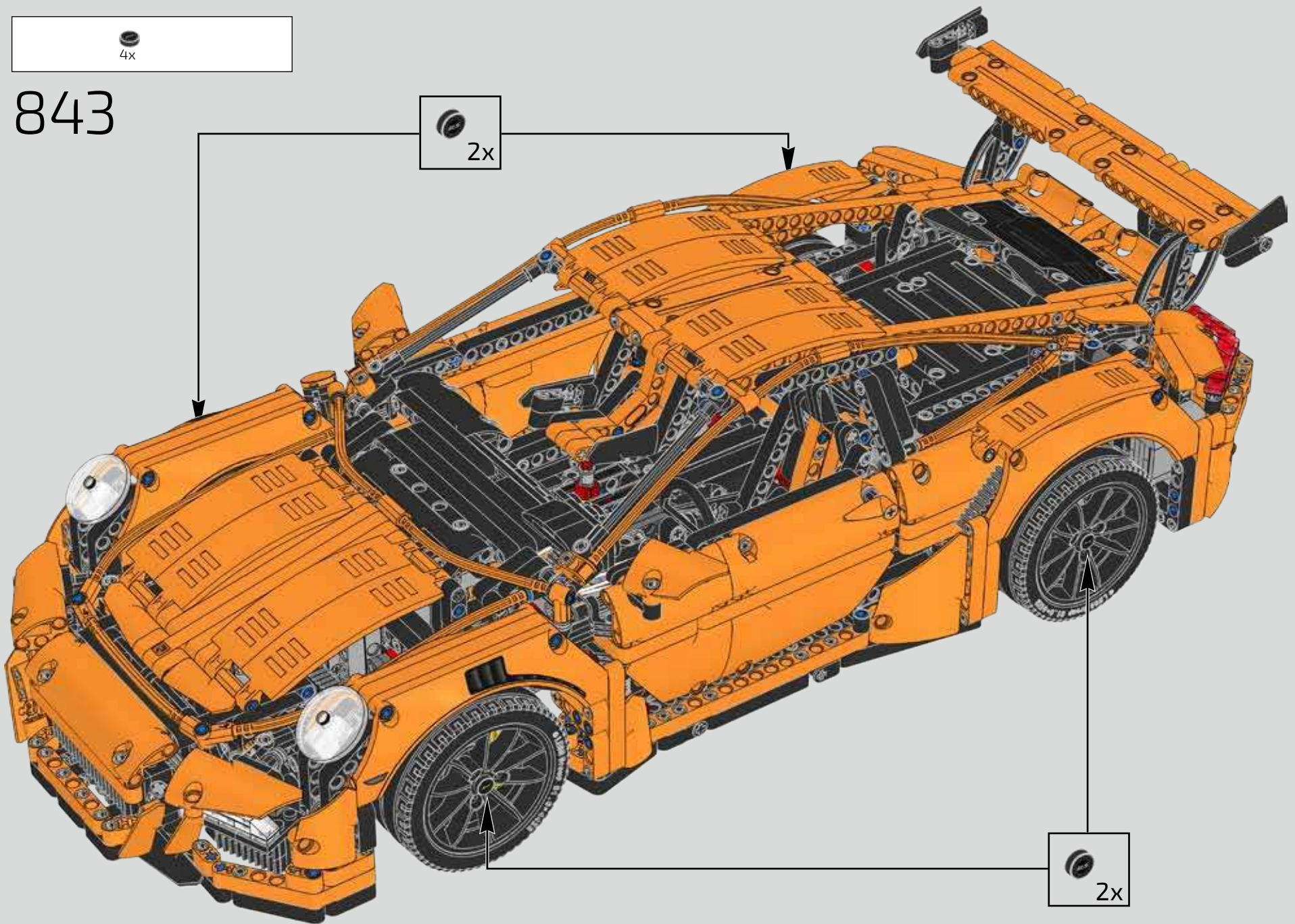
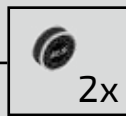

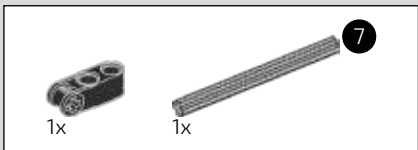

844

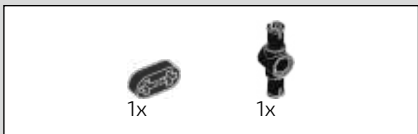
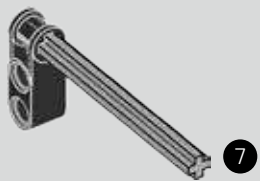

845

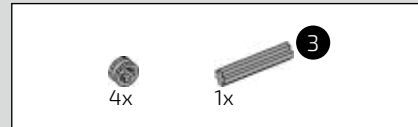
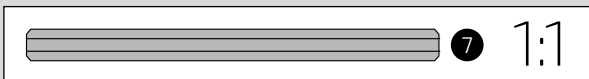
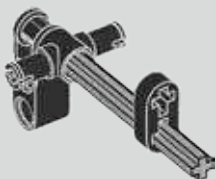

846

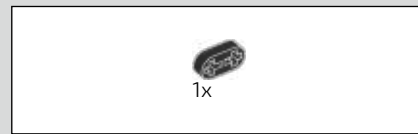
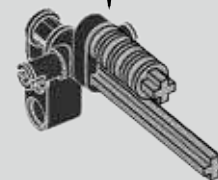
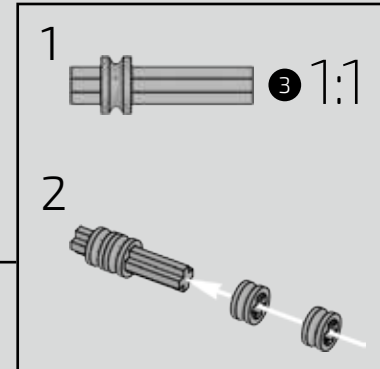

847

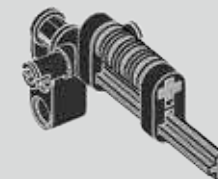



848

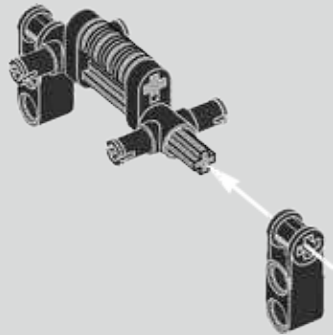

849

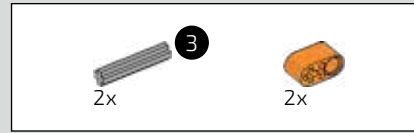
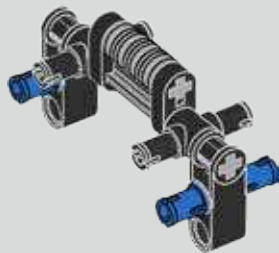

850

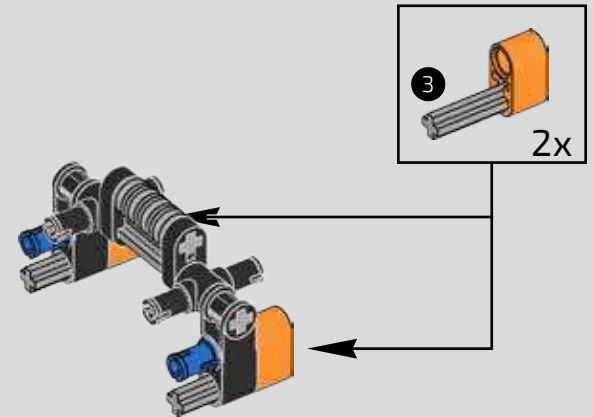

851

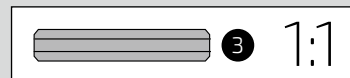
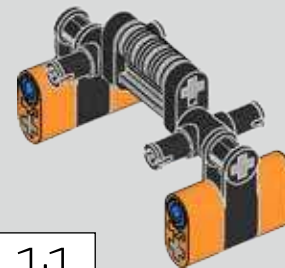



852

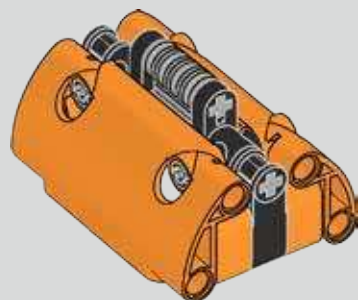

853

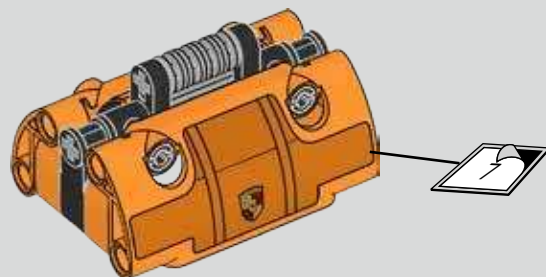
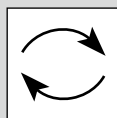

854

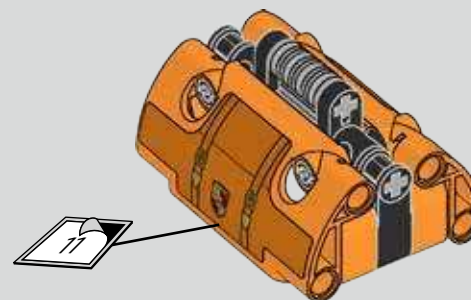
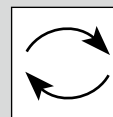

855

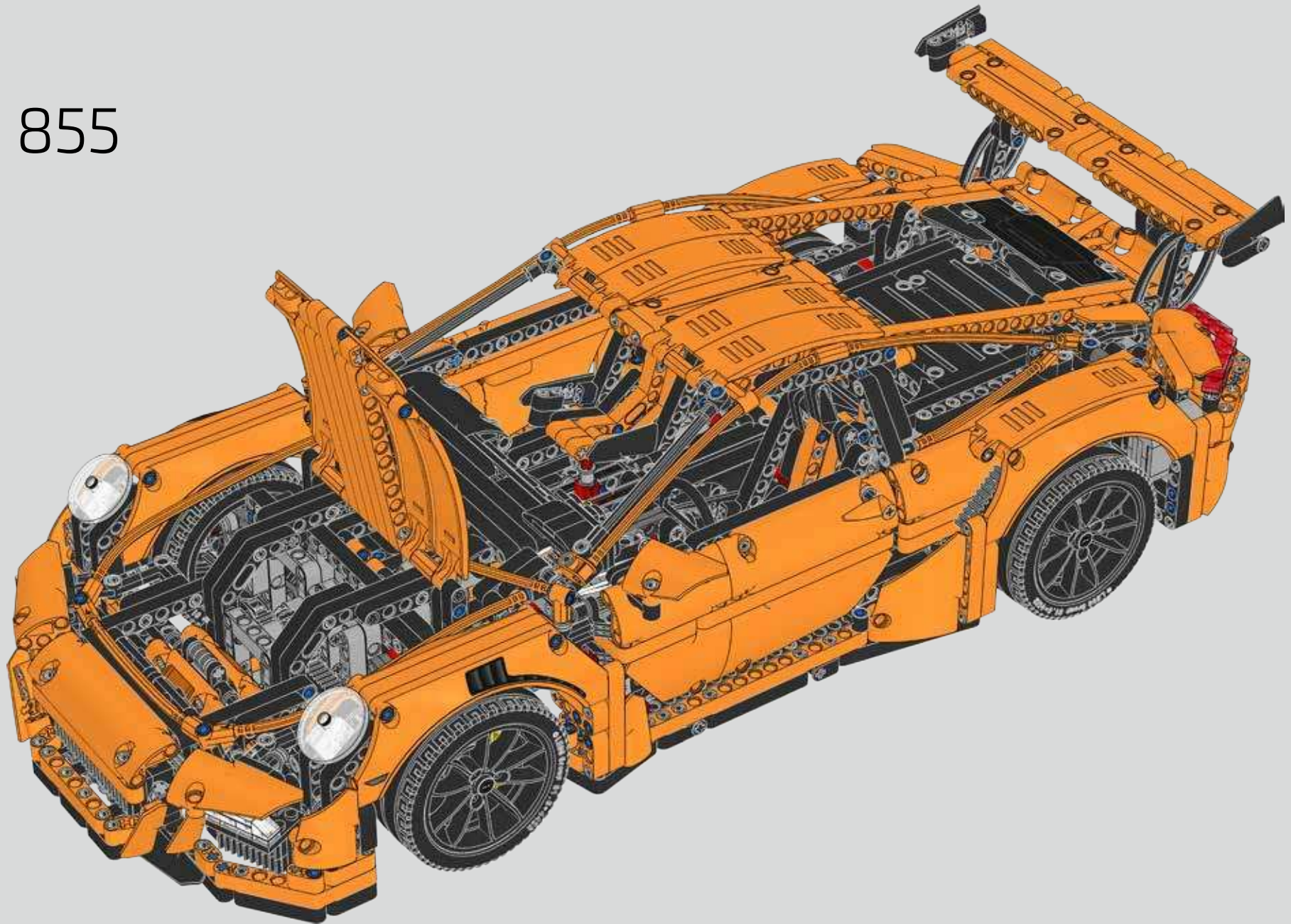

856

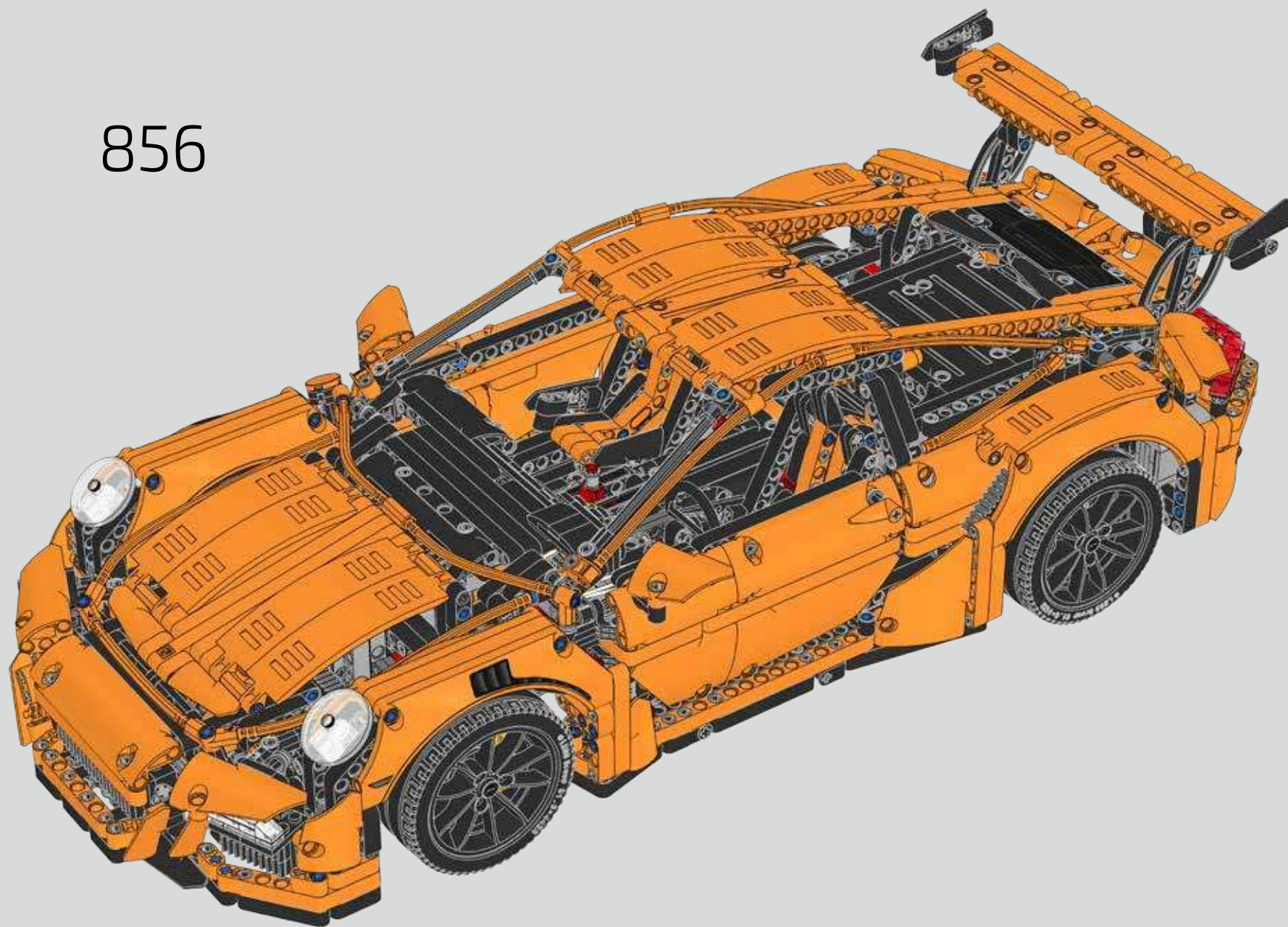

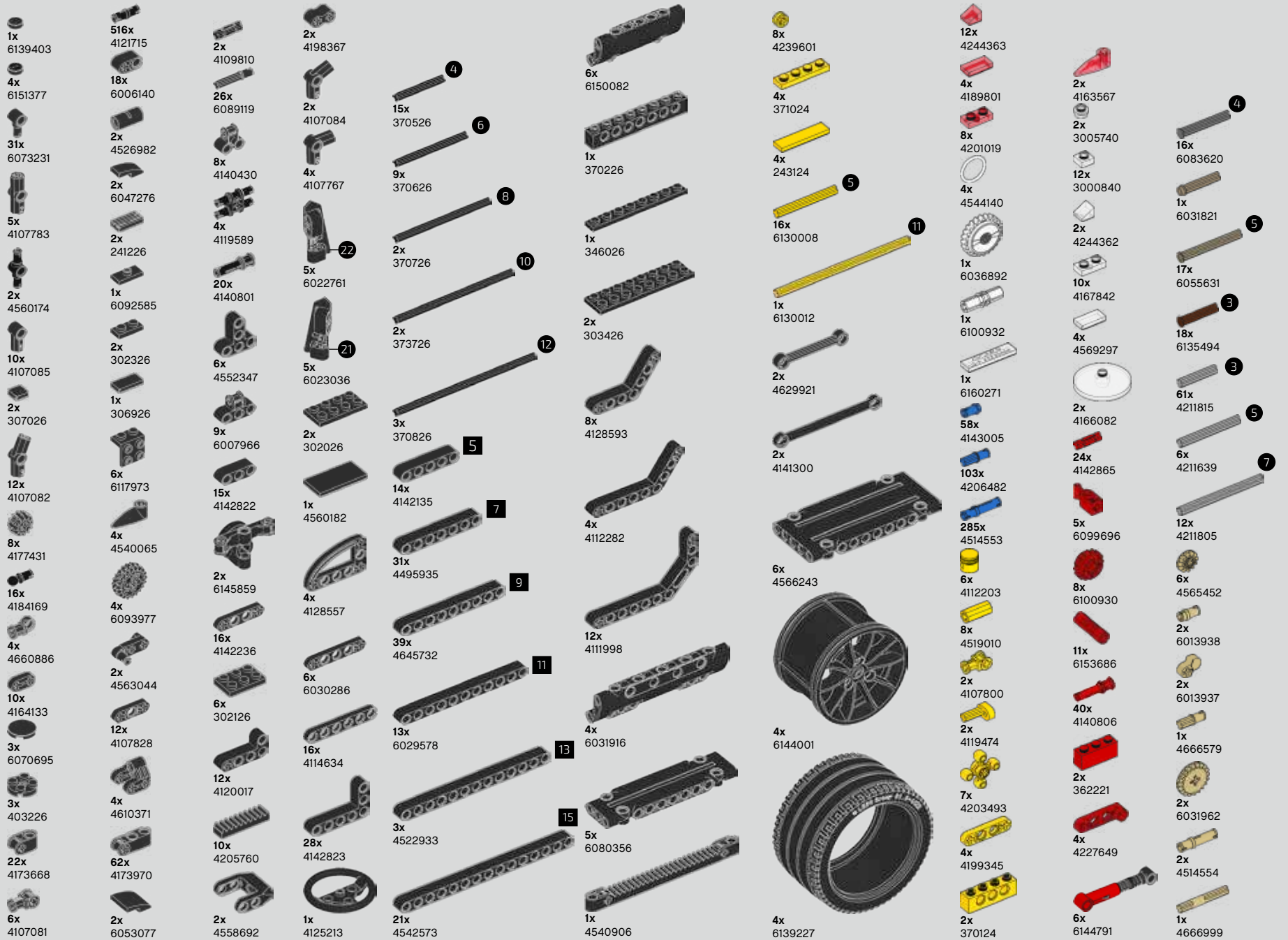

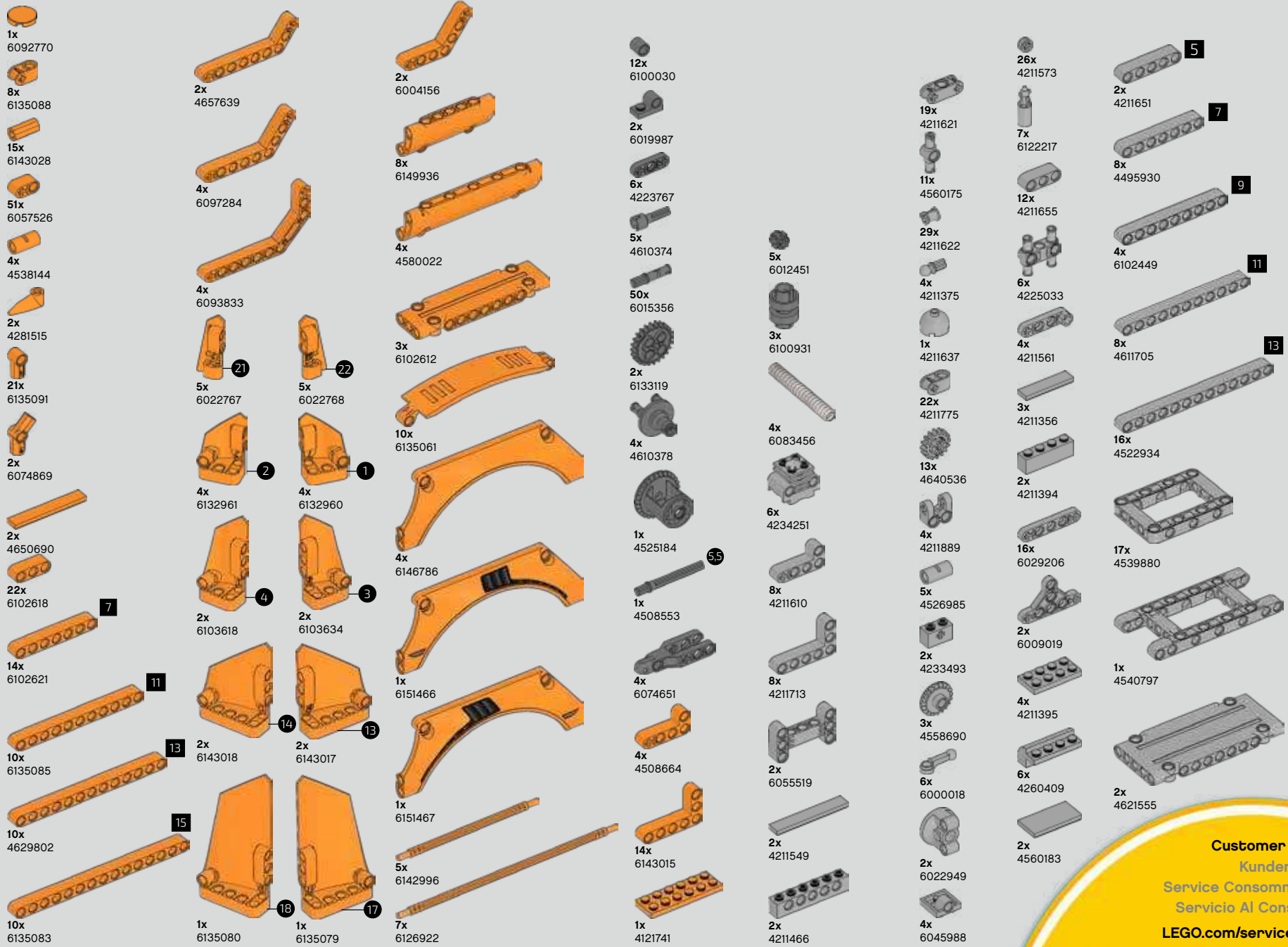

1x 6092770
 8x 6135088
 15x 6143028
 51x 6057526
 4x 4538144
 2x 4281515
 21x 6135091
 2x 6074869
 2x 4650690
 22x 6102618
 14x 6102621
 10x 6135085
 10x 4629802
 10x 6135083

2x 4657639
 4x 6097284
 4x 6093833
 5x 6022767
 4x 6132961
 2x 6103618
 2x 6103634
 2x 6143018
 2x 6143017
 1x 6135080
 1x 6135079

2x 6004156
 8x 6149936
 4x 4580022
 3x 6102612
 10x 6135061
 4x 6146786
 1x 6151466
 1x 6151467
 5x 6142996
 7x 6126922

12x 6100030
 2x 6019987
 6x 4223767
 5x 4610374
 50x 6015356
 2x 6133119
 4x 4610378
 1x 4525184
 1x 4508553
 4x 6074651
 4x 4508664
 14x 6143015
 1x 4121741

5x 6012451
 3x 6100931
 4x 6083456
 6x 4234251
 8x 4211610
 8x 4211713
 2x 6055519
 2x 4211549
 2x 4211466

19x 4211621
 11x 4560175
 29x 4211622
 4x 4211375
 1x 4211637
 22x 4211775
 13x 4640536
 4x 4211889
 5x 4526985
 2x 4233493
 4x 4558690
 6x 6000018
 2x 6022949
 4x 6045988

26x 4211573
 7x 6122217
 12x 4211655
 6x 4225033
 4x 4211561
 3x 4211356
 2x 4211394
 16x 6029206
 2x 6009019
 4x 4211395
 6x 4260409
 2x 4560183

2x 4211651
 8x 4495930
 4x 6102449
 8x 4611705
 16x 4522934
 17x 4539880
 1x 4540797
 2x 4621555

Customer Service
 Kundenservice
 Service Consommateurs
 Servicio Al Consumidor
 LEGO.com/service or dial
 : 00800 5346 5555
 : 1-800-422-5346





Do you like the set?

The LEGO Group would like your opinion on the new product you have just purchased. Your feedback will help shape the future development of this LEGO set. Please visit LEGO.com/productfeedback

By completing our short feedback survey, you will be automatically entered into a draw to win a LEGO prize. Terms and conditions apply.

Gefällt dir das Set?

Die LEGO Group würde sich freuen, deine Meinung zu dem gerade gekauften Produkt zu erfahren. Dein Feedback trägt zur Weiterentwicklung dieses LEGO Sets bei. Bitte gehe auf LEGO.com/productfeedback

Durch das Ausfüllen unserer kurzen Feedback-Befragung nimmst du automatisch an einer Verlosung für einen LEGO Preis teil. Es gelten die Allgemeinen Geschäftsbedingungen.

LEGO.com/productfeedback



Use your unique code on our website, LEGO.com/technic, to access a special gift!

Gebe deinen einmaligen Fahrzeug-Code auf unserer Website LEGO.com/technic ein und erhalte ein besonderes Geschenk!





Porsche Museum, Stuttgart.



Ensin
SPO

S-PX 6842

S-GO 89H



Porsche Museum, Stuttgart.



LEICHT

W 24-6450

LEMAUS' PORSCH E 27-025

A-2-3 LEMANS 82 27-026 ENDMIX

A-2-3 LEMANS 87 27-026 GESCHN

324 CARBERA GT/LEMAUS 80/ ENDMIX

324 CARBERA
UNIKENROB

27-027

315

316

317

318

319

320

B15

IX DEUTSCH

HNITENES

IX DT./16.23

ARCEBA G. / LETIANS BO
ORIGINAL + ENDPIX DEUTSCH

Titel	
Verfasser	
Verlag	
Abt. Nr.	

TITEL	
Verfasser	
Verlag	
Abt. Nr.	

